

## DRIVER, TRACK & RESULTS

**DRIVER** *yugo Naagashima* COUNTRY *JAPAN* **WEATHER** AIR TEMP TRACK TEMP  DRY  INTERMEDIATE  WET  
**TRACK** *しらかば2ni1* **CONDITION**  ASPHALT  CARPET  LOW  MEDIUM  HIGH  BUMPY  SMOOTH  
**RACE** *Japan nationals* DATE *7/20~7/21* QUALIFICATION *9th* BEST LAP TIME *15.2* FINAL *8th*

**FRONT DRIVE TRAIN REAR**

GEAR DIFF  GEAR DIFF *6000*  
 SPOOL

**HEAVE DAMPER**

OIL *1000* OIL *1500*  
 SPRINGS *orange* SPRINGS *orange*  
 SHIM *1* mm SHIM *1* mm

**ROLL DAMPER**

OIL *5000* OIL *7500*  
 SPRINGS *red* SPRINGS *red*  
 HOLES

**REAR REACTIVE SYSTEM**

RRS LINK SHIMS *3* mm  NO RRS LINK

**CHASSIS FLEX CONFIGURATION TOP DESK**

STANDARD  MAGNESIUM STIFF  STANDARD  
 ALU 2MM  MAGNESIUM FLEX  VERTICAL

**TYRES** Controlled

BRAND/TYPE *sweep*  
 INSERTS  
 ADDITIVE *v3*  
 TIME  
 SURFACE

**ELECTRONICS**

BATTERY *trion*  
 MOTOR *trion v2 5.0T* TIMING *34*  
 ESC *trion* RECEIVER *RX-491*  
 SERVO *b7* RADIO *m17*

**RATIO CONFIGURATION**

PINION SPUR GEAR *112* PITCH *64*  
 FINAL RATIO *7* ROLLOUT mm

**AERODYNAMIC CONFIGURATION**

BODY *PF turismo* WING *hard*  
 BODY POSITION mm

REMARKS

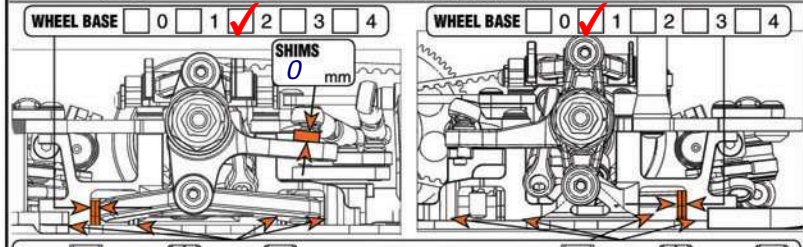
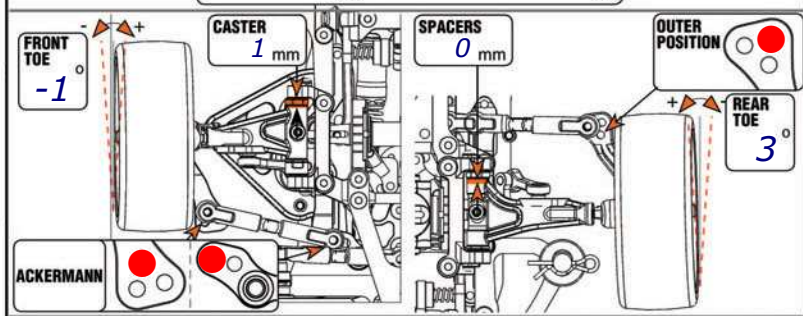
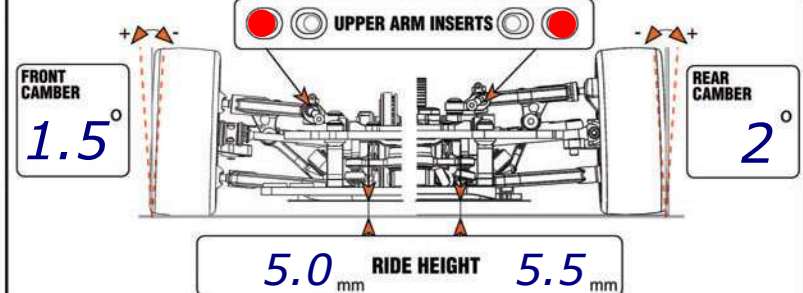
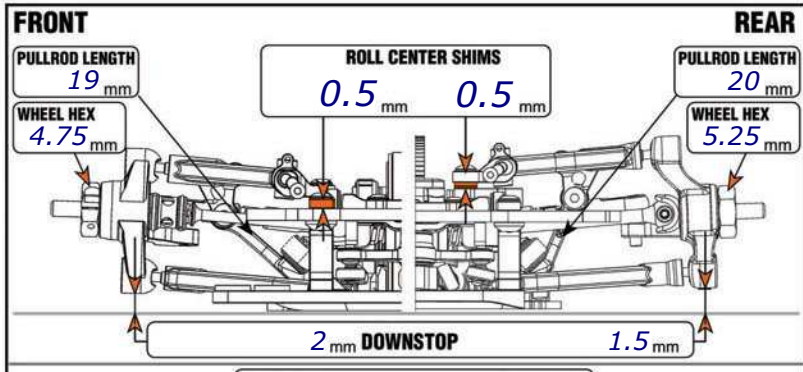

**MID LOW MID HIGH HIGH ROLL CENTER BOTTOM INSERTS MID LOW MID HIGH HIGH**

**WEIGHT DISTRIBUTION**  
 BATTERY  STD  SHORTY SERVO LOCATION  LEFT  RIGHT  
 BATT POSIT.  FR  MID  RR CAR WEIGHT *1357* Grs

