

1.0 SHOCK ABSORBER ASSEMBLY

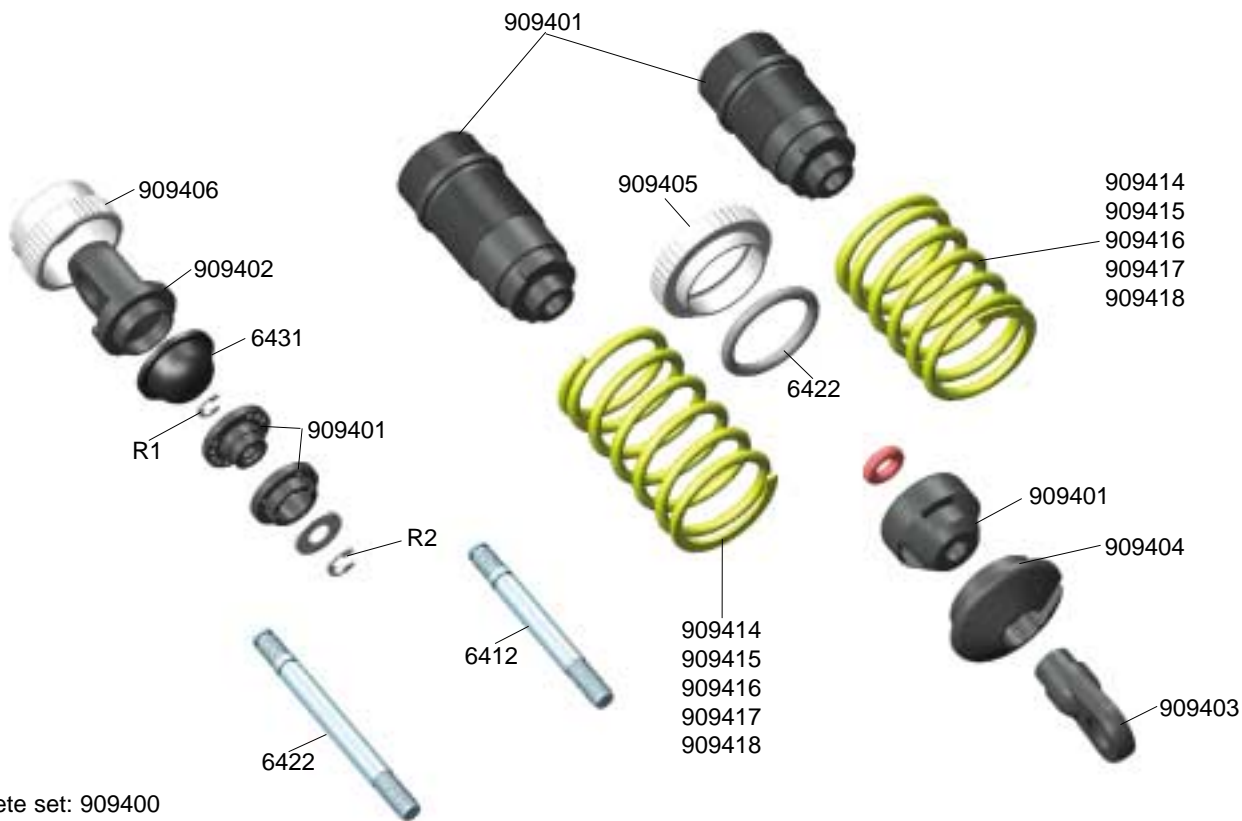

Step 1.1

Bag A

N3 3x6x0.3mm

R2 2.3mm

R1 1.9mm

Thread the piston (4) onto the shock shaft until tight

Apply the c-clip (2) to the groove at the end of the shock shaft.

Long shock shaft goes into long shock body (6)

CompetitionX
A WEB SITE FOR THE SERIOUS RACER



Step 1.2

Y17 12.1x1.6mm

Y4 3.1x1.6mm

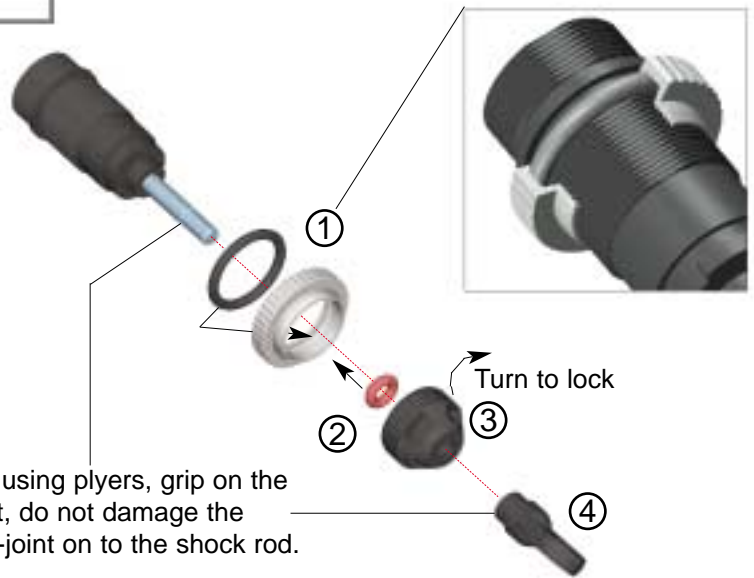

- ④ Hold the shock rod firm using pliers, grip on the end of the threaded part, do not damage the shock rod. Turn the ball-joint on to the shock rod.

Step 1.3



Fill the cylinder with shock oil, with the piston in the bottom position.

Bleeding sequence: Let the oil settle and allow the air to escape. Slowly move the piston up and down until no more bubbles appear.



- ② Glue the membrane to the bottom of the shock head using a CA glue



Step 1.4



Shock length adjustment: Check the length of the shocks, adjust with the ball-joint.

Shock Front: 67,5mm
Shock Rear: 76,5mm

In full extended, locked position.

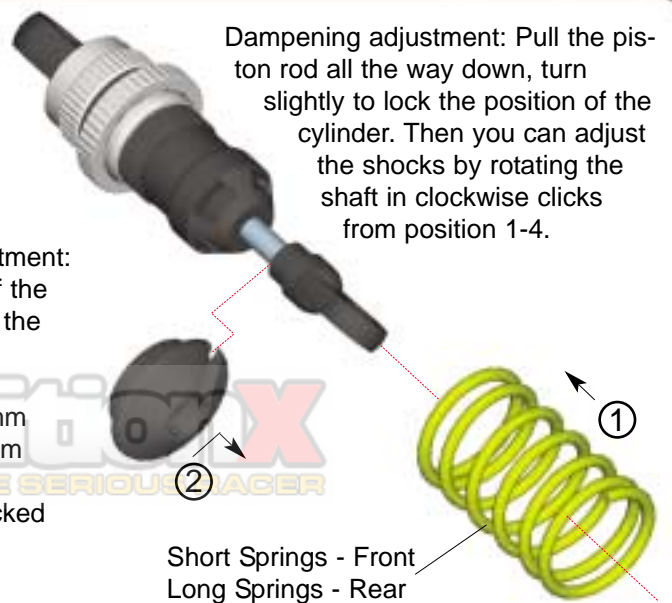

Dampening adjustment: Pull the piston rod all the way down, turn slightly to lock the position of the cylinder. Then you can adjust the shocks by rotating the shaft in clockwise clicks from position 1-4.

Short Springs - Front
Long Springs - Rear

2.0 REAR ASSEMBLY

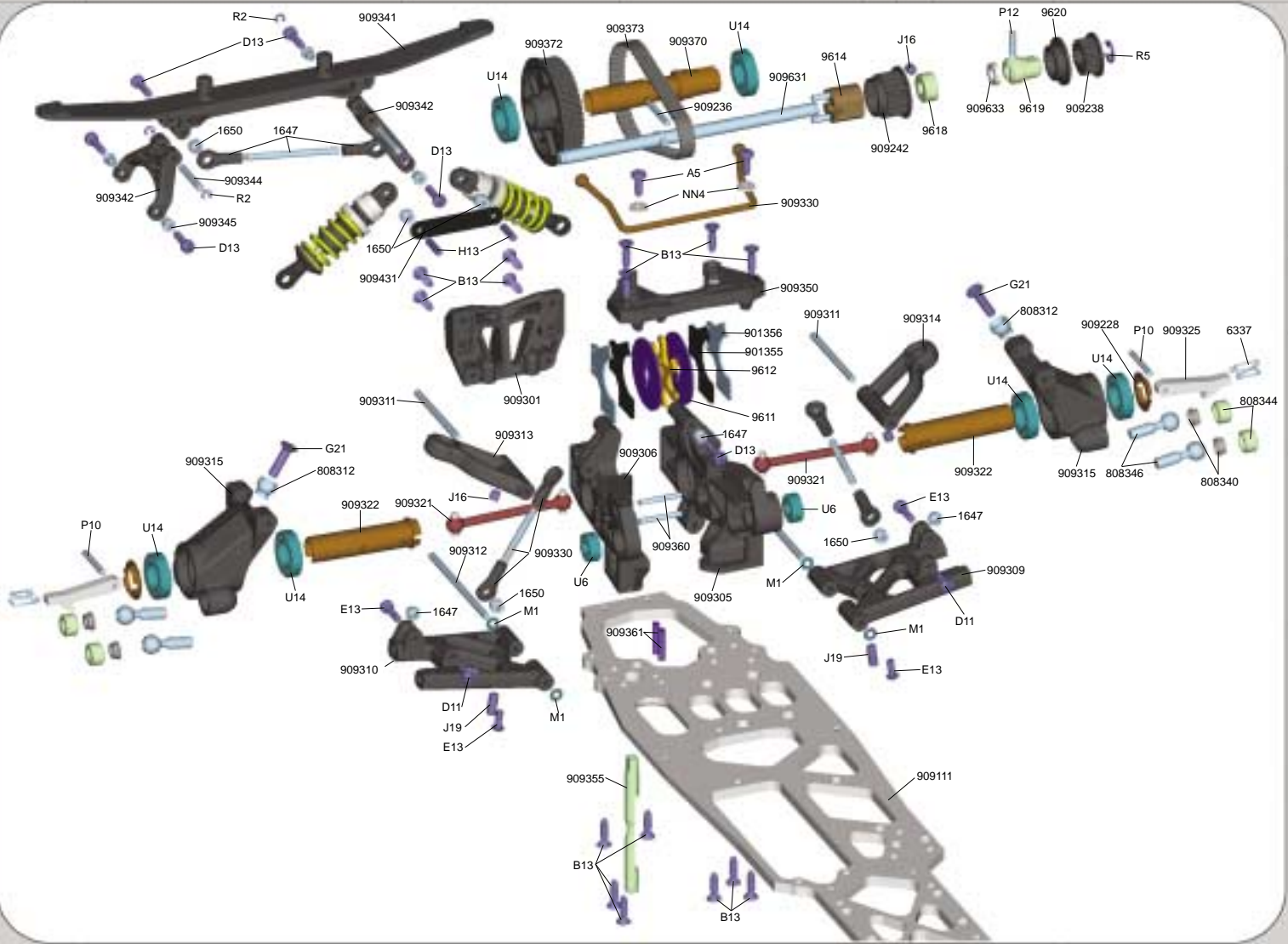

Step 2.1

Bag B,C,U,B13

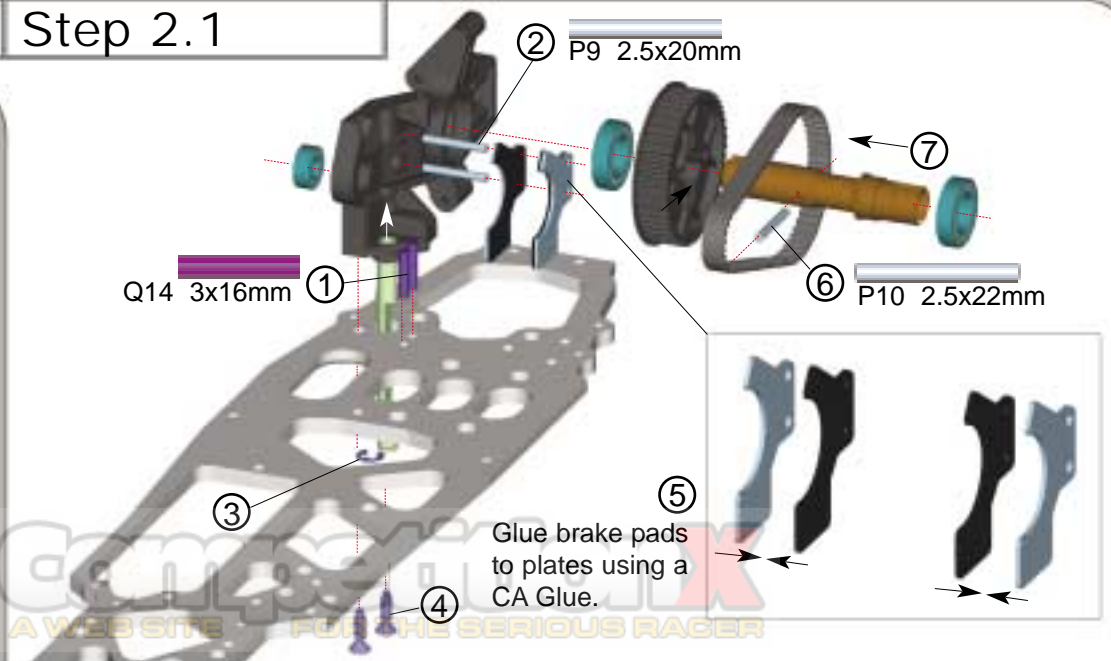
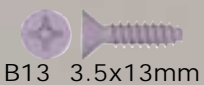
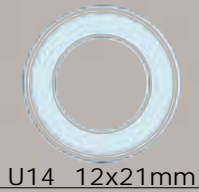

Roughen the steel plates with rough sandpaper before gluing the brake pads to the steel brake plates.



Step 2.2

Bag D,E,B13,U



R5 5mm



B13 3.5x13mm



J16 4x4mm



U6 6x13mm

P12 3x12mm

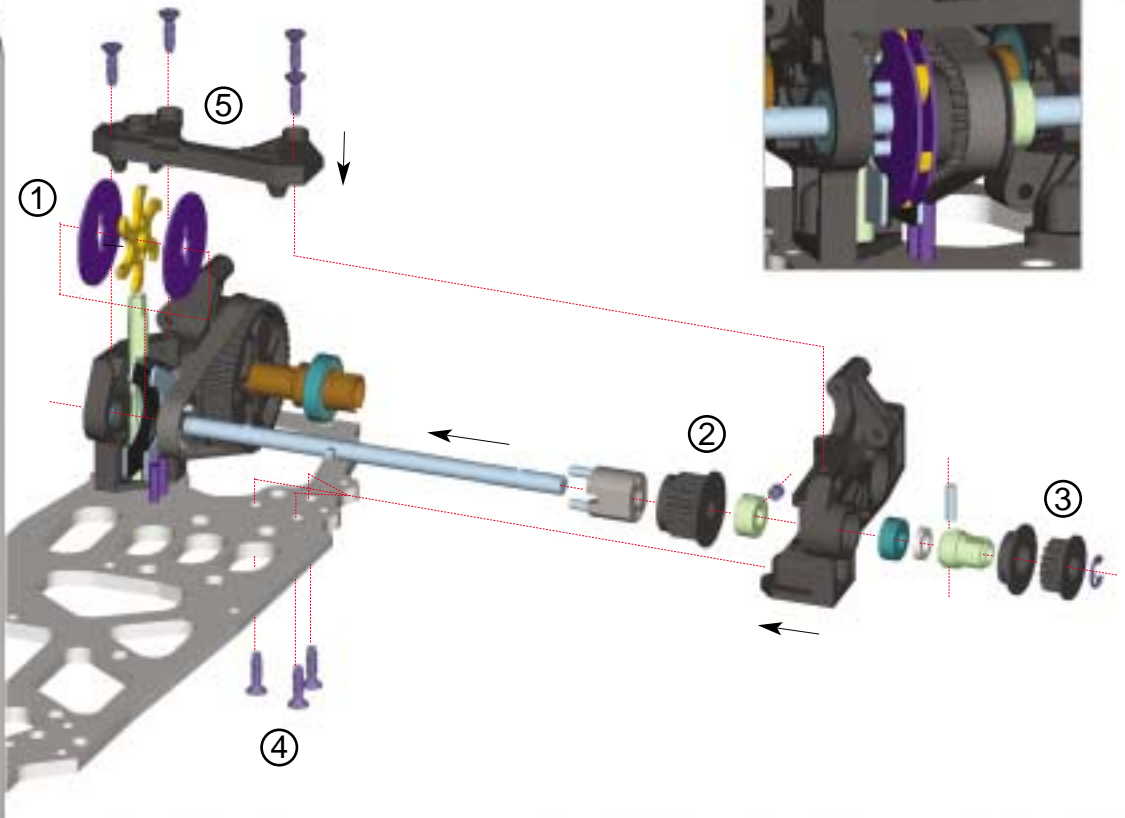

Flatten the brake discs using some sandpaper to remove high spots for more consistent braking.

Step 2.3

Bag F,G,B13

M1 3x6x0.1mm



B13 3.5x13mm

J16 4x4mm

E11 3x8mm



D11 3x8mm

H19 4x10mm

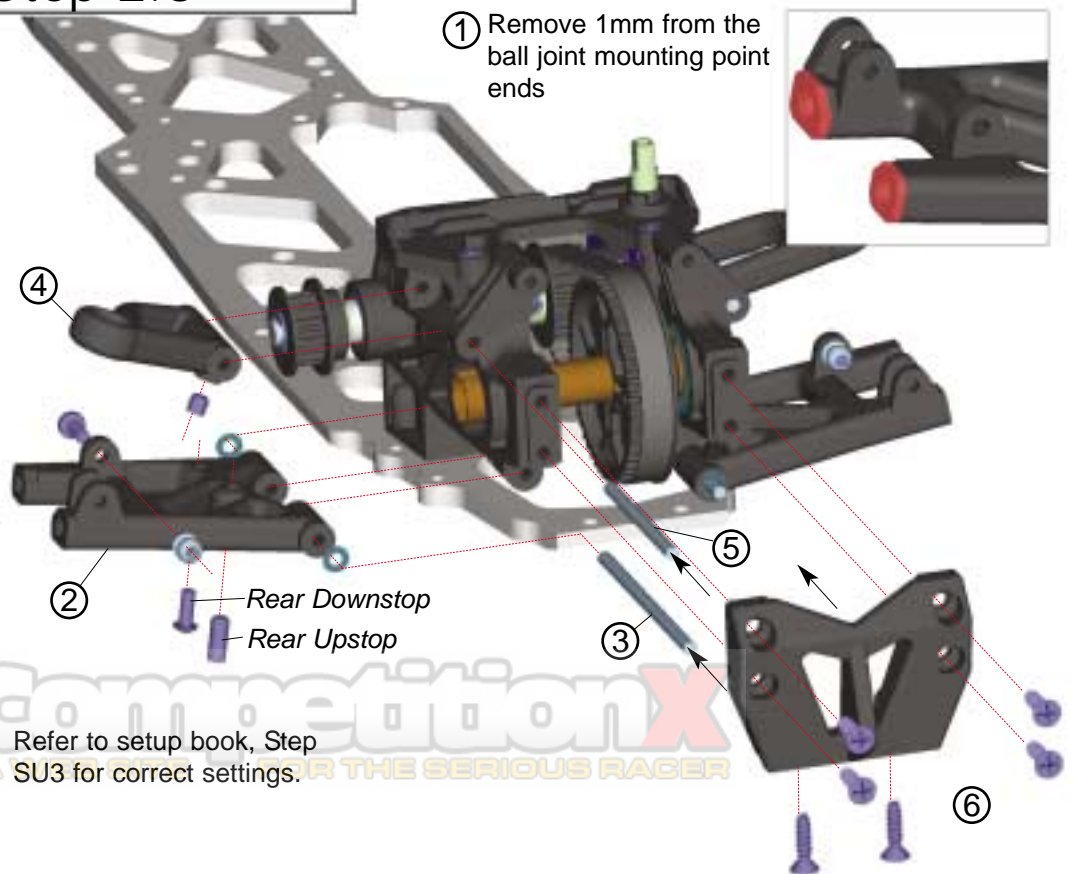

Refer to setup book, Step SU3 for correct settings.

Step 2.4

Bag H,I,U



U14 12x21mm

P10 2.5x22mm

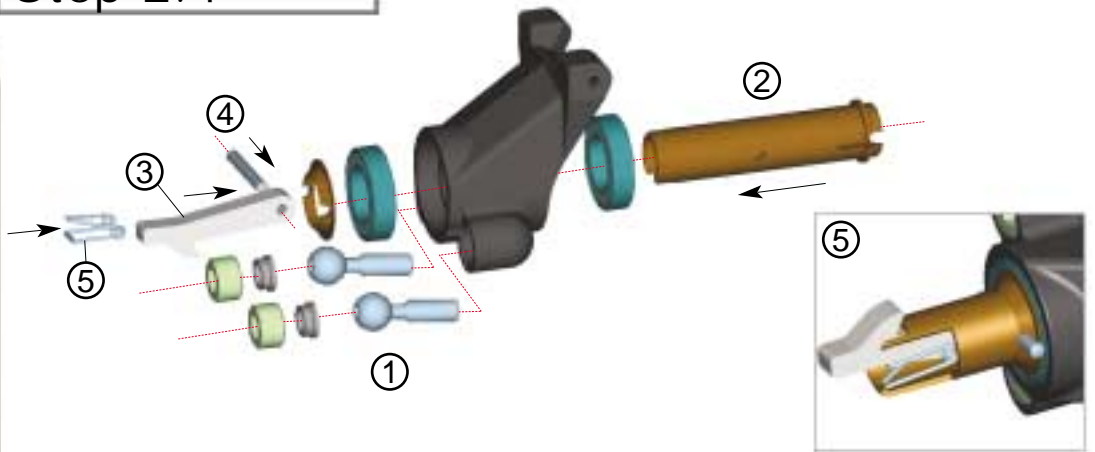

Step 2.5



G21 4x16mm

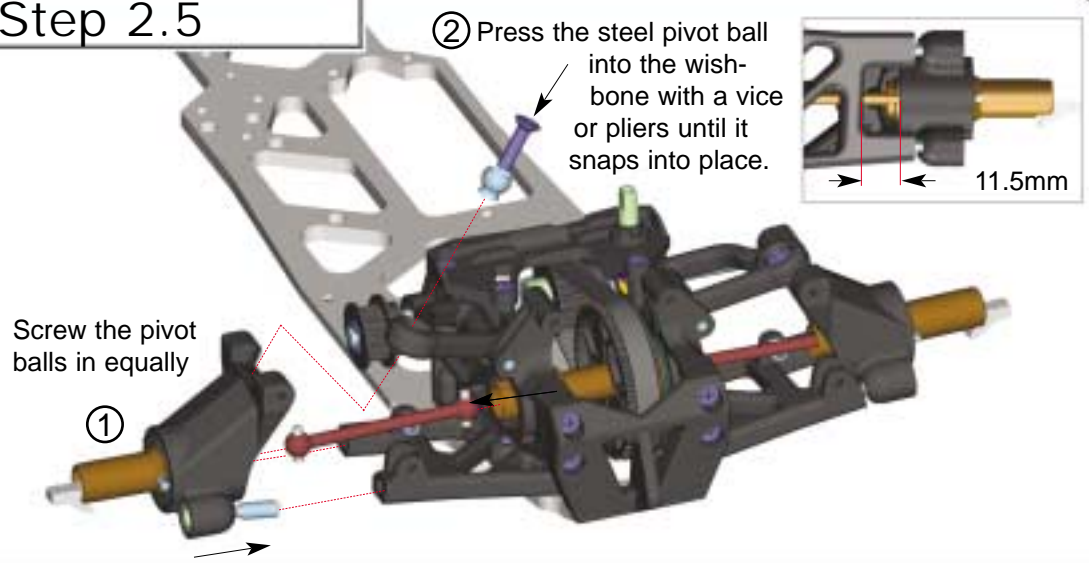

② Press the steel pivot ball into the wishbone with a vice or pliers until it snaps into place.

To make the steel pivot ball go easier into the wishbone, lightly coat with some thin oil. To lengthen the life of your driveshafts, use a graphite spray or grease on the driveshaft ends.

Step 2.6

Bag K



NN4 3.2x9x0.5mm



A5 2.9x9.5mm

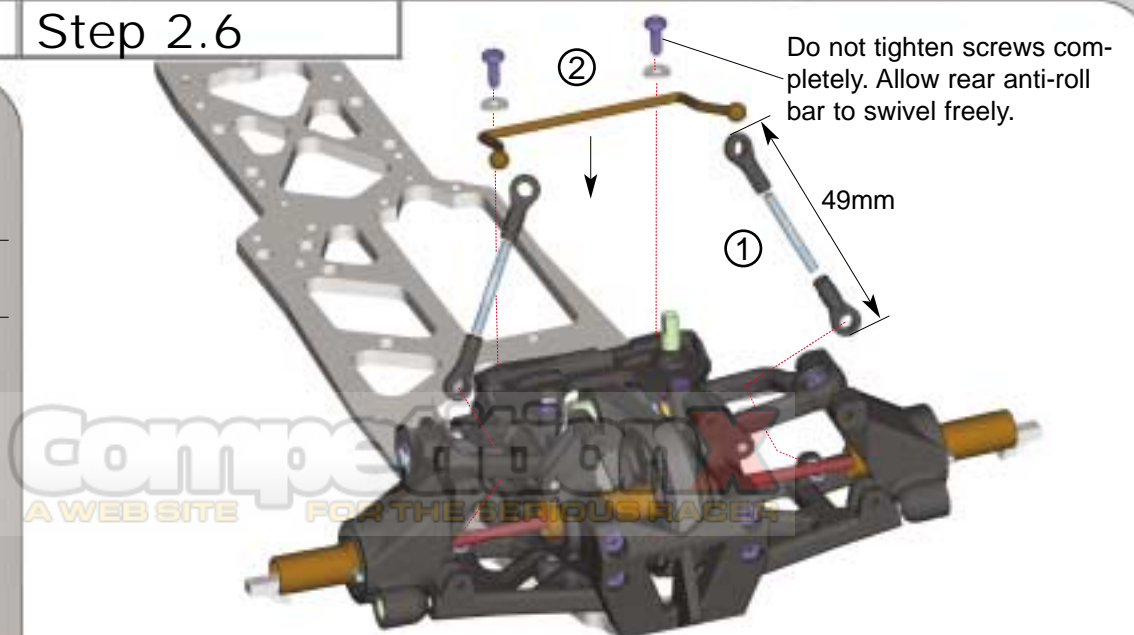

COMPE
A WEB SITE FOR THE SERIOUS RACER.



Step 2.7

Bag L,M

R2 2.3mm

D13 3x12mm

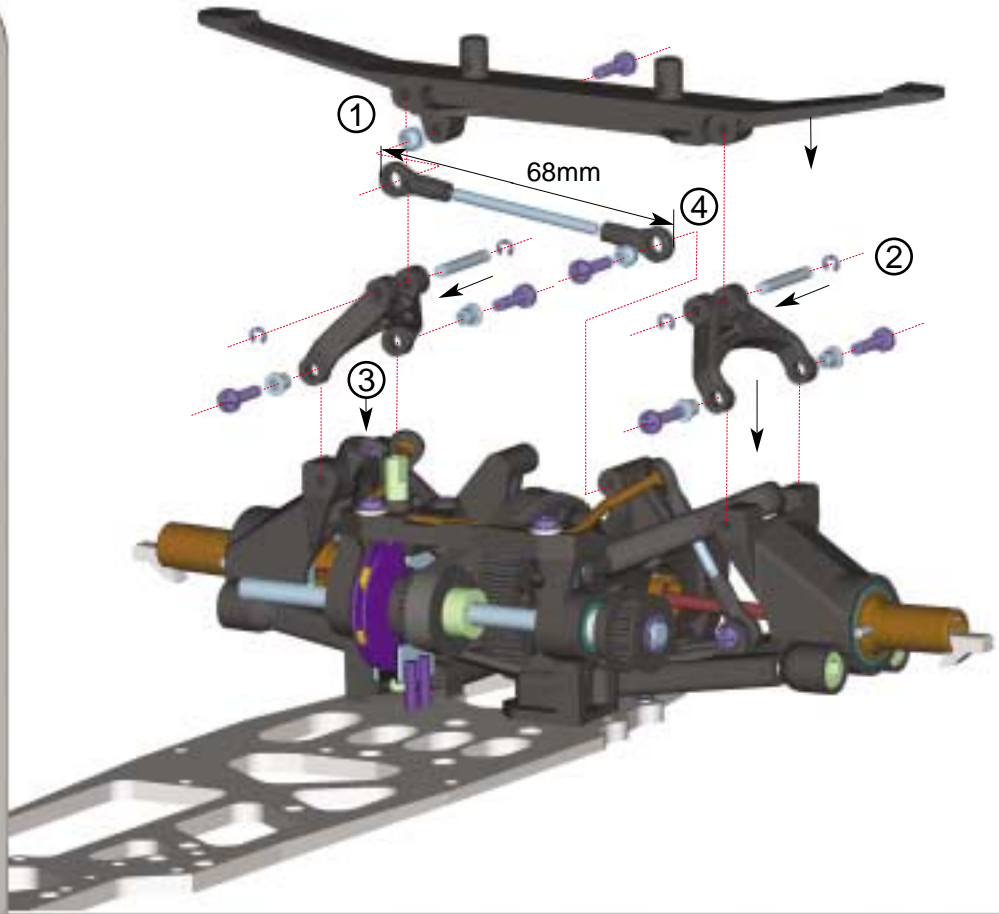

Step 2.8

H13 3x12mm

E13 3x12mm



3.0 FRONT ASSEMBLY

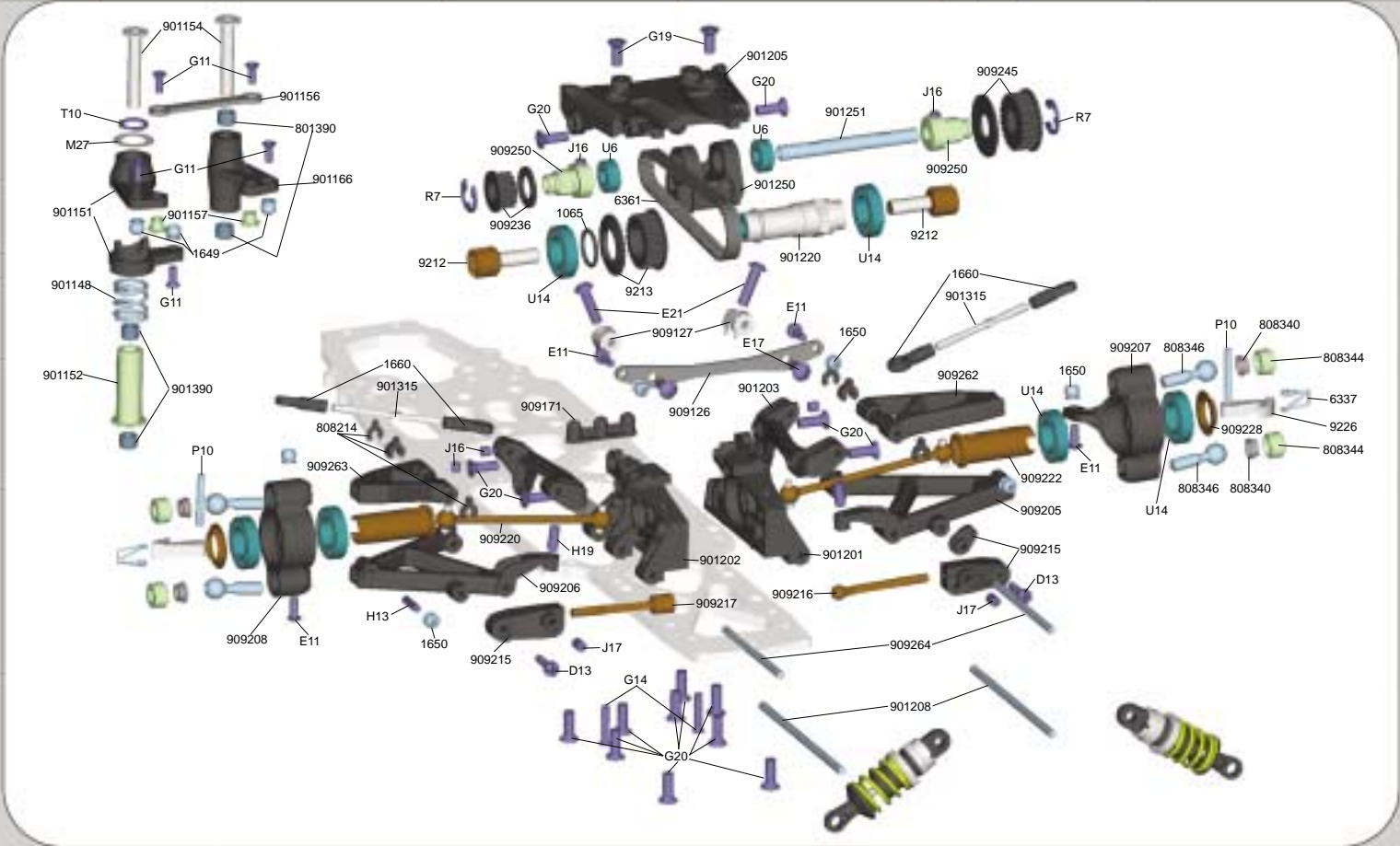

Step 3.1

Bag N,U,G20

J16 4x4mm



R7 7mm



U6 6x13mm



G20 4x12mm

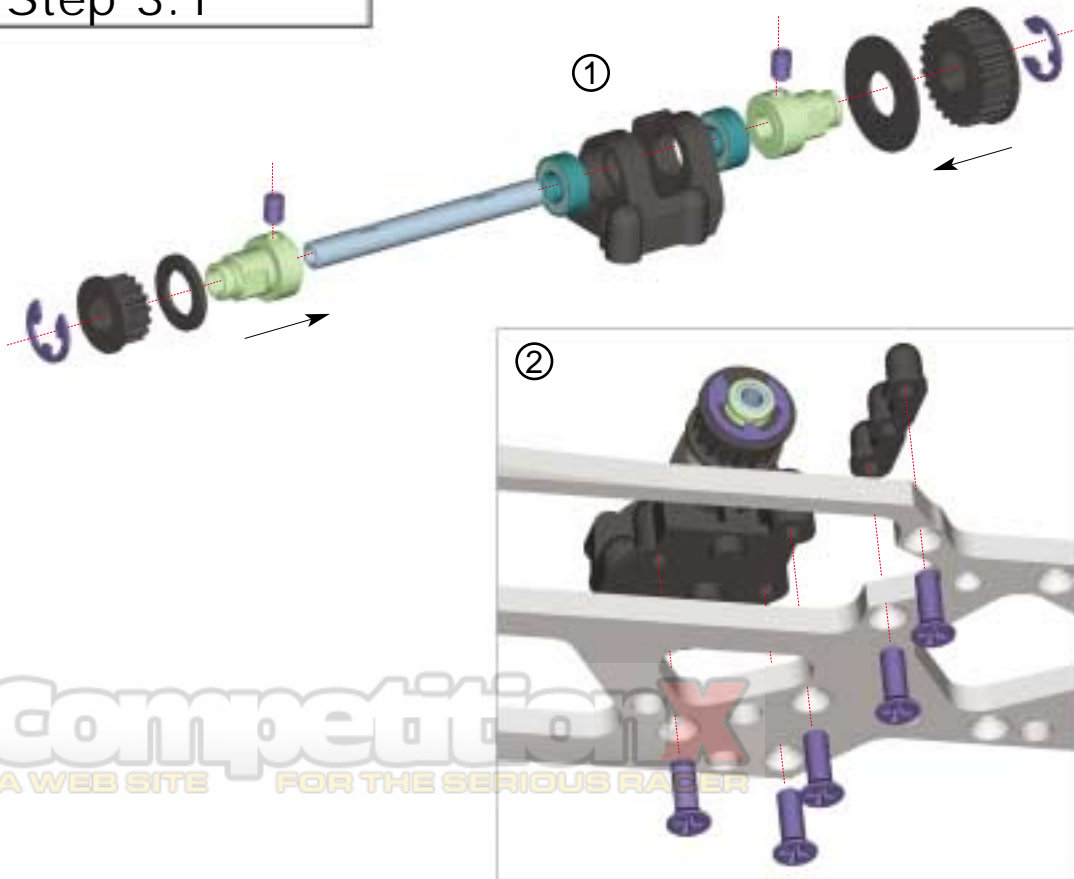

Competitive X
A WEB SITE FOR THE SERIOUS RACER



Step 3.2

Bag O



M27 10x16x0.3mm



T10 10mm



G11 3x8mm

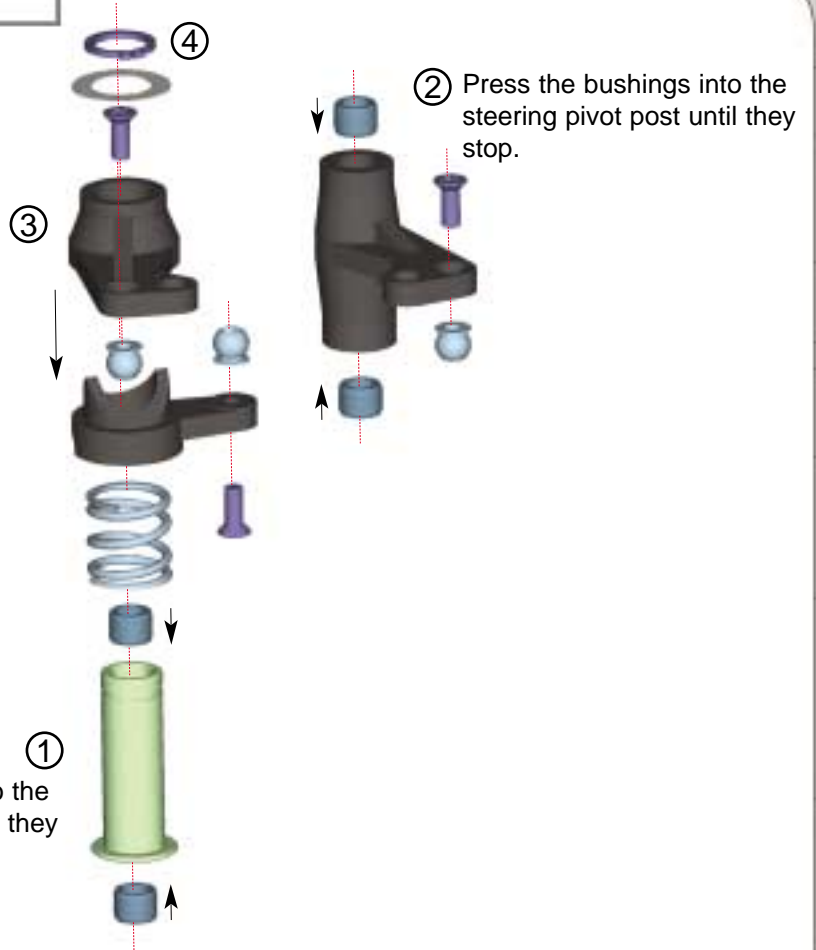

Step 3.3

Bag P



G11 3x8mm



G14 3x16mm

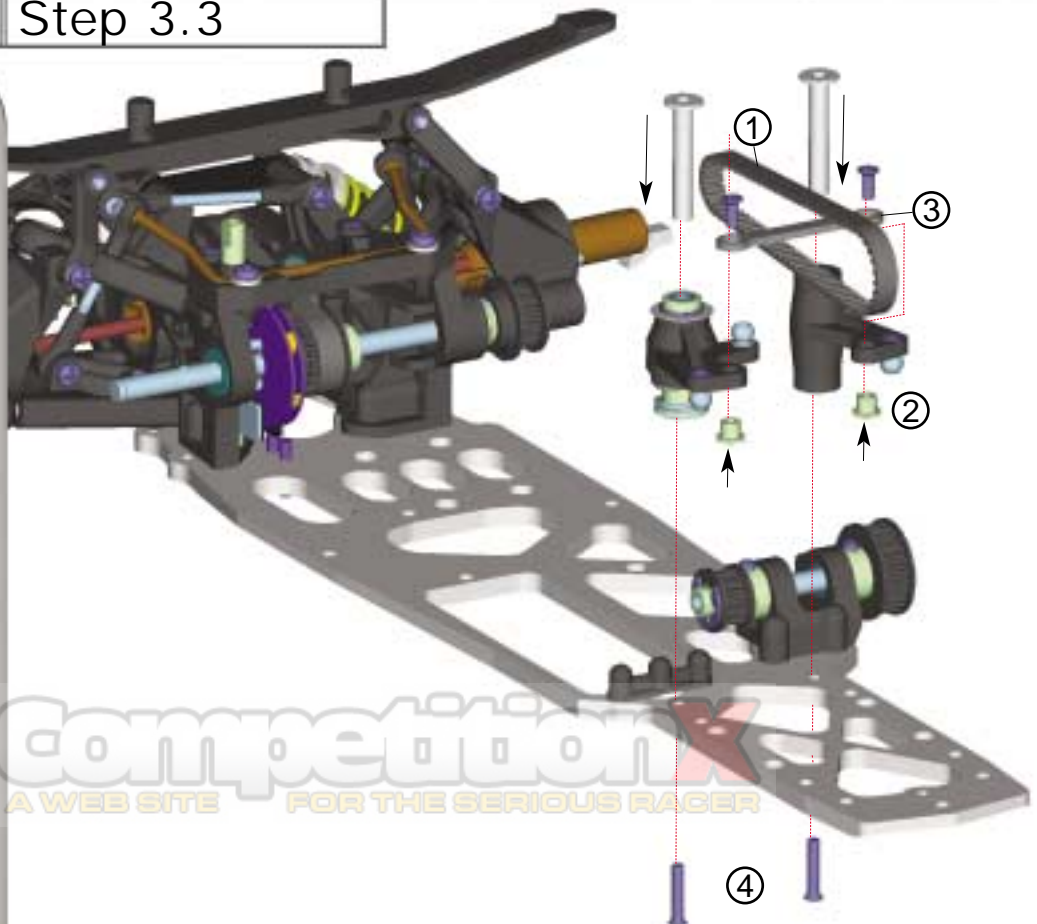

Step 3.4

Bag R,U,G19,G20



U14 12x21mm



Y12 10.3x1.8mm

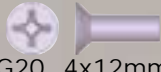

G20 4x12mm

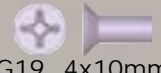

G19 4x10mm

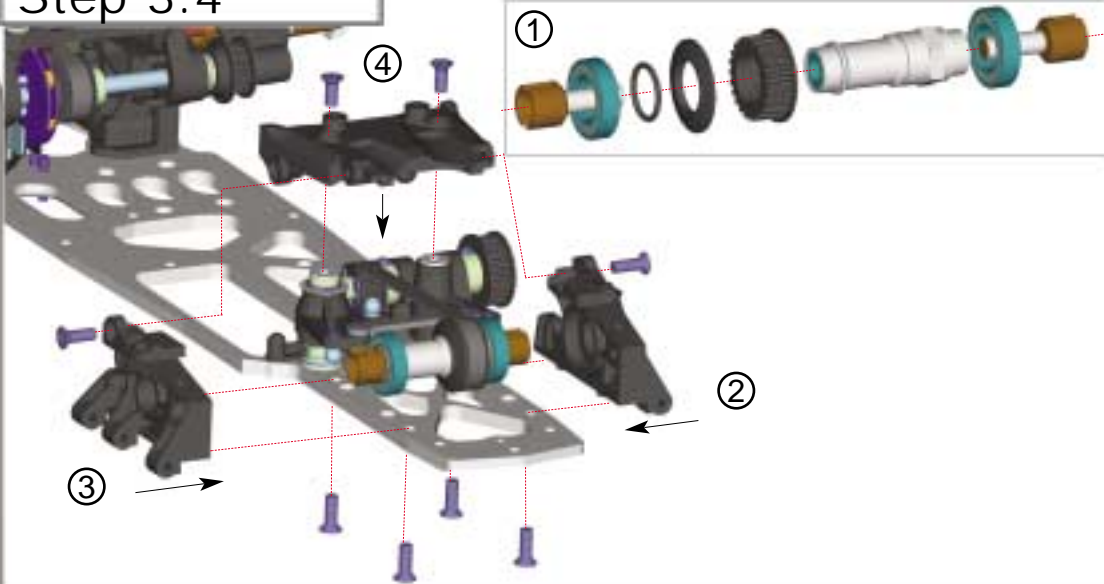

Step 3.5

Bag S,G20

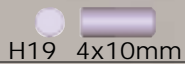

H19 4x10mm

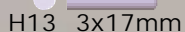

H13 3x17mm



J16 4x4mm

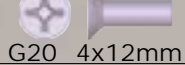

G20 4x12mm

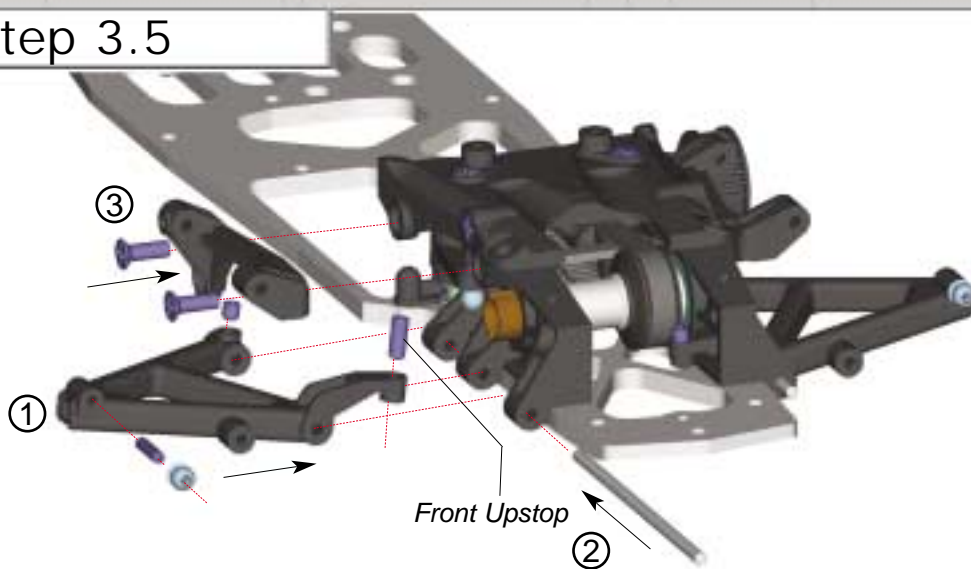

Step 3.6

Bag T,V



J16 4x4mm



J17 4x6mm



H19 4x10mm

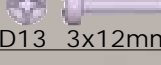

D13 3x12mm

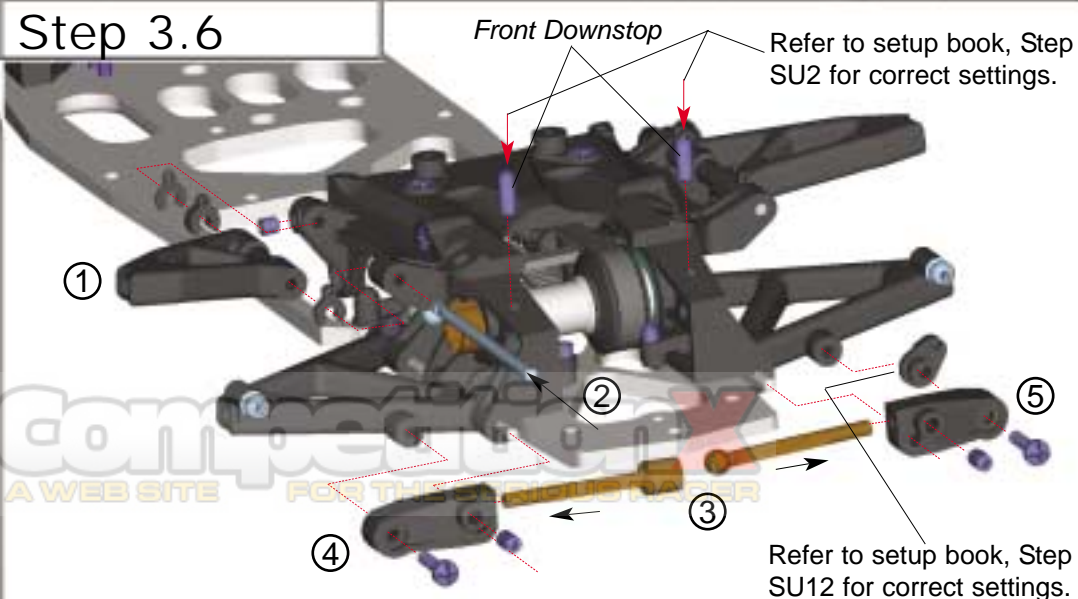

Step 3.7

Bag W,X,U



U14 12x21mm

P10 2.5x22mm



The left steering block can be distinguished by 4 dots.

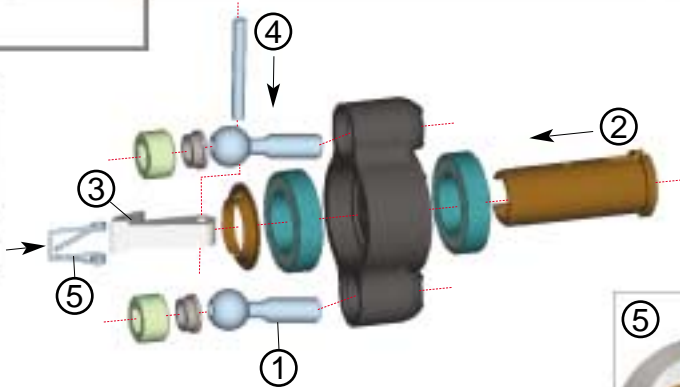

Step 3.8



E11 3x8mm

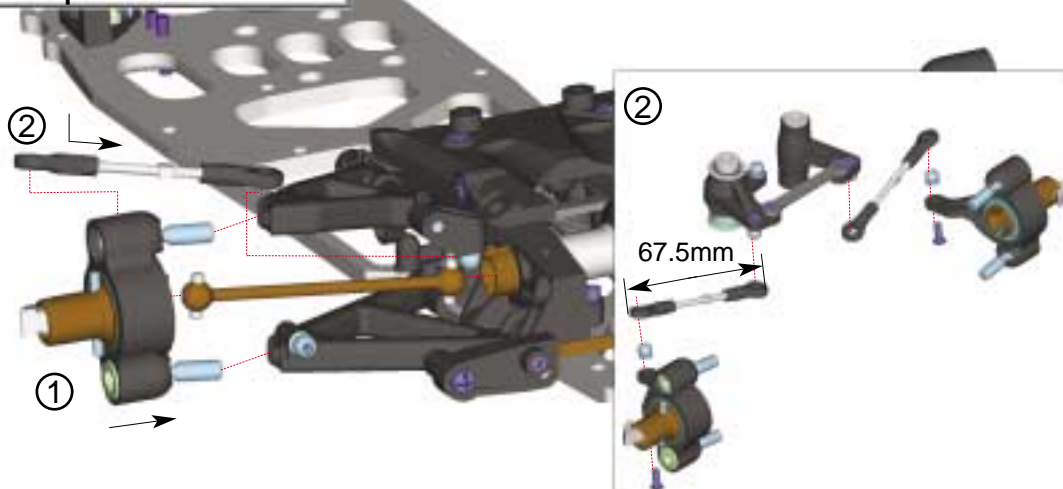

To lengthen the life of your driveshafts, use a graphite spray or grease on the driveshaft ends.

Step 3.9

Bag Y

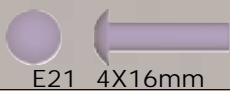

E21 4X16mm

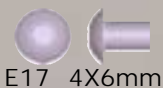

E17 4X6mm

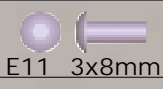

E11 3x8mm

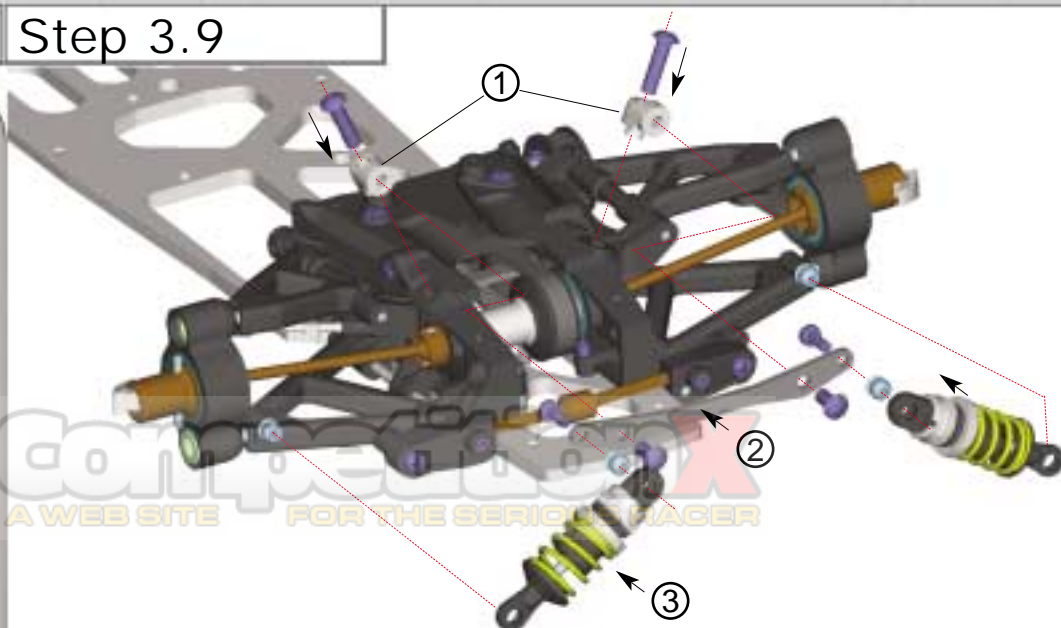

4.0 RADIOPLATE ASSEMBLY

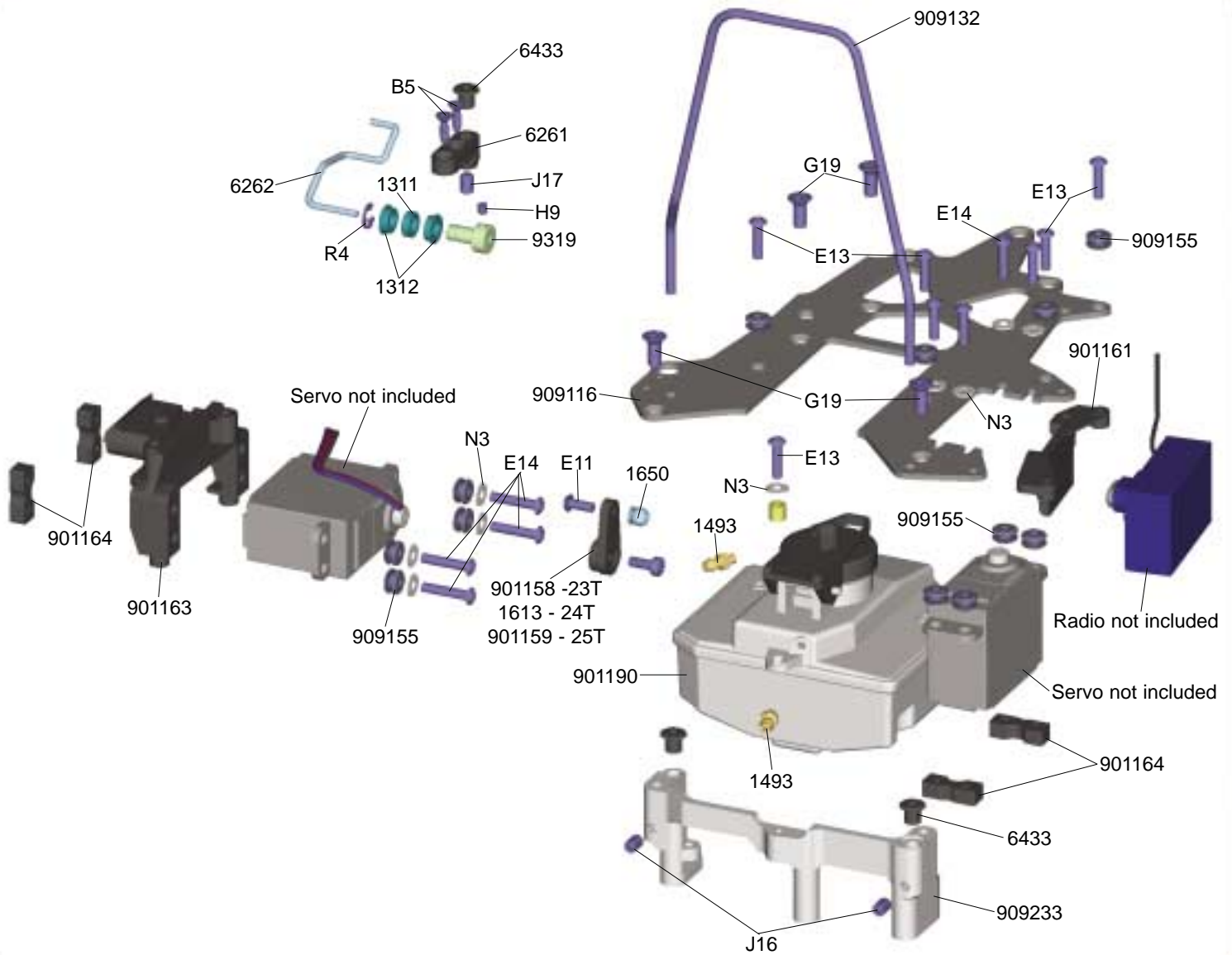

Step 4.1

Bag Z

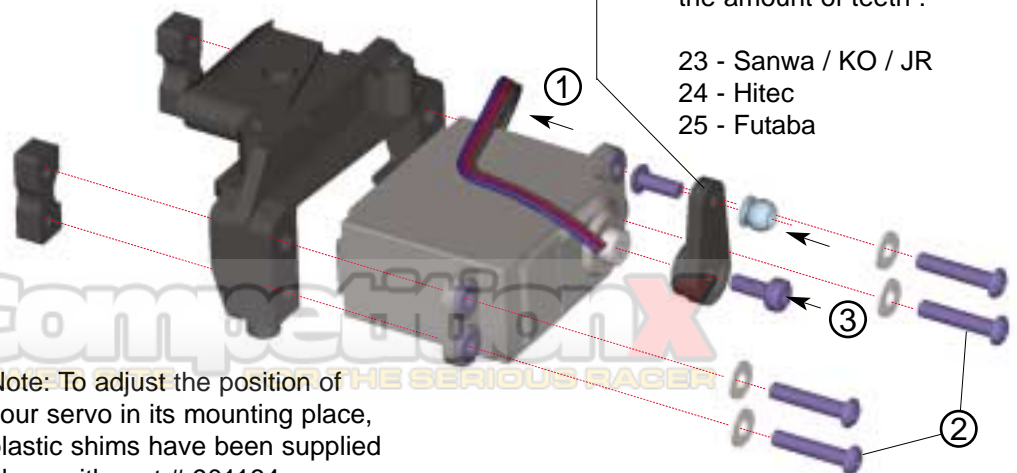
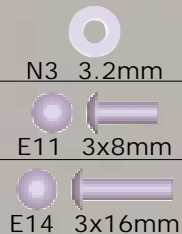

Note: To adjust the position of your servo in its mounting place, plastic shims have been supplied along with part # 901164



Step 4.2

Bag AA,AB,G19

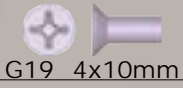

G19 4x10mm



E13 3x12mm

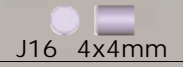

J16 4x4mm

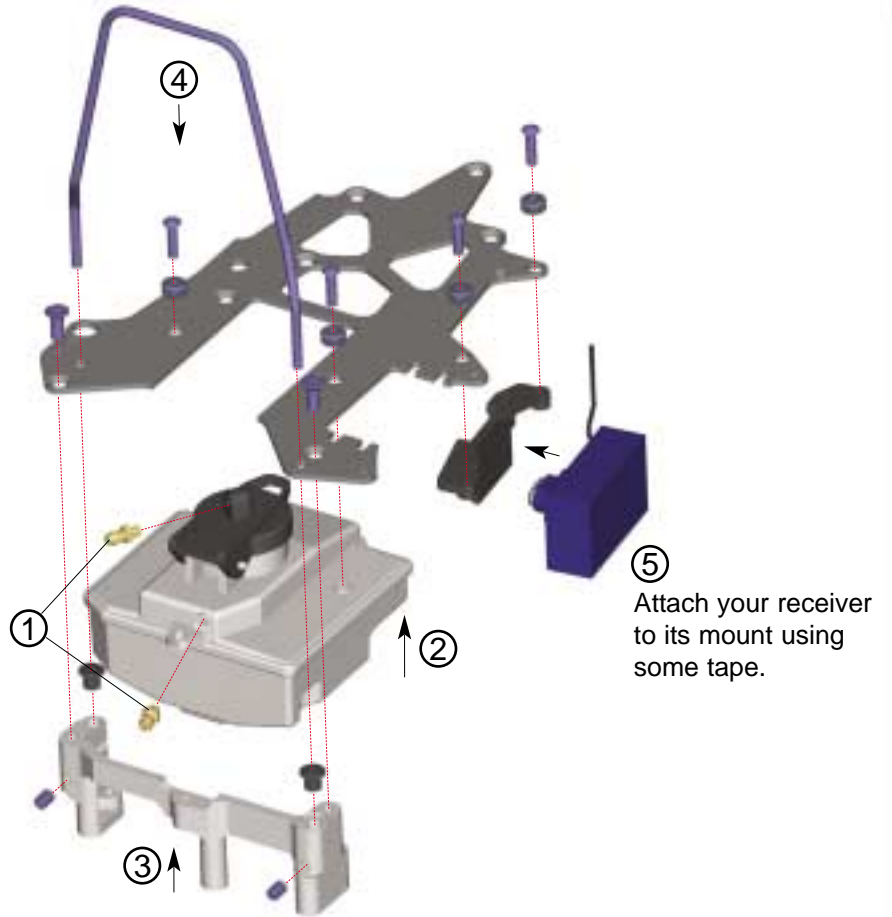

Step 4.3

Bag AC,AD,G19

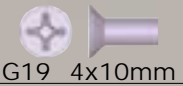

G19 4x10mm



E13 3x12mm

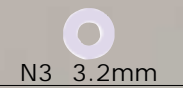

N3 3.2mm

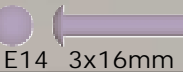

E14 3x16mm

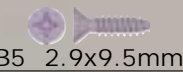

B5 2.9x9.5mm

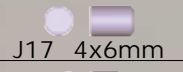

J17 4x6mm

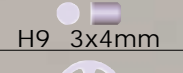

H9 3x4mm



R4 4mm

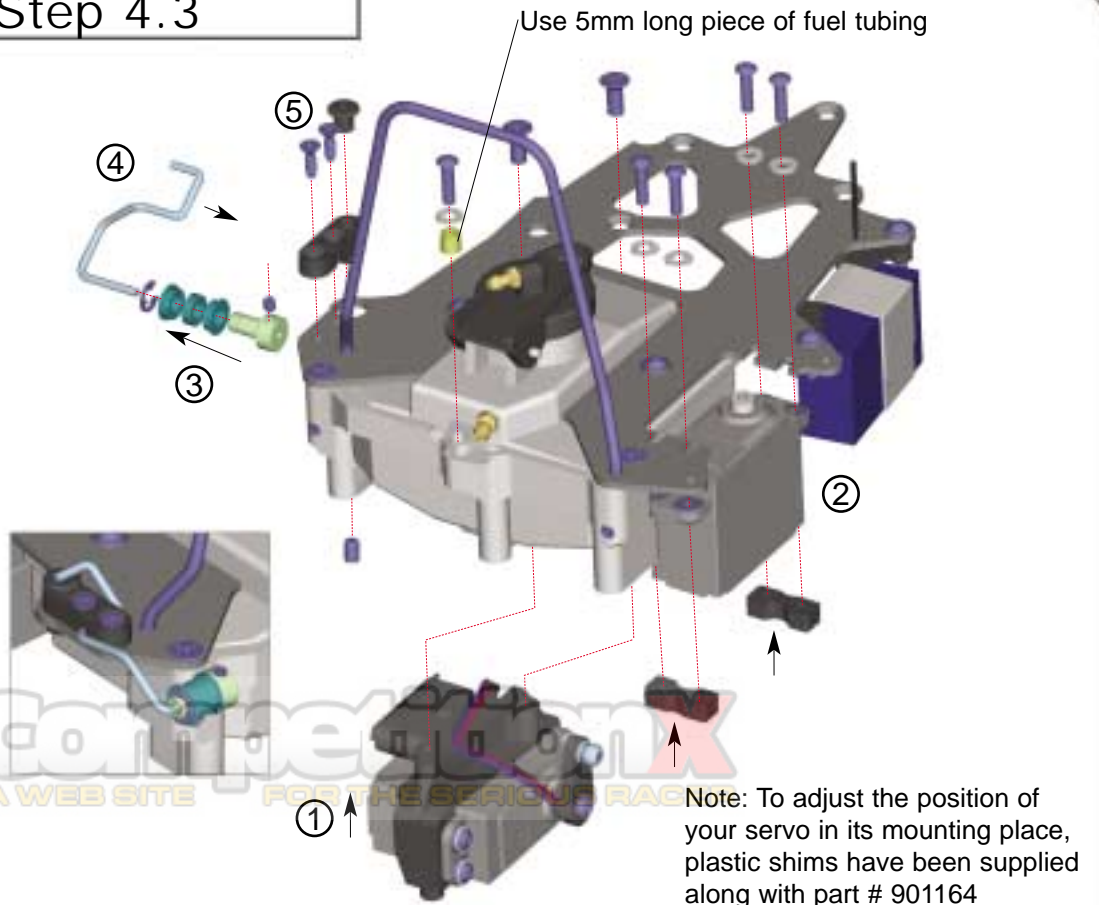

5.0 CENTAX CLUTCH ASSEMBLY

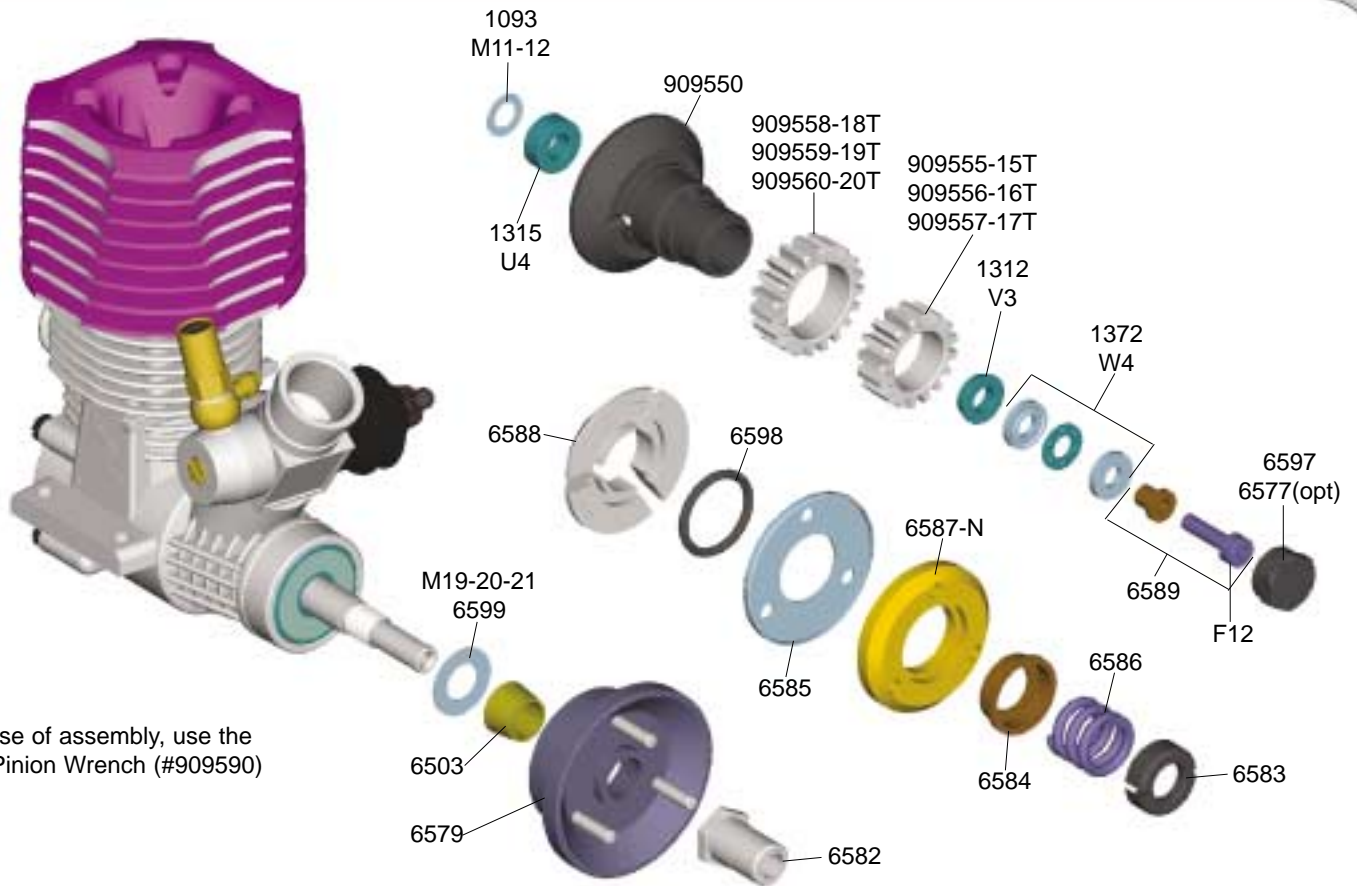

For ease of assembly, use the Gear Pinion Wrench (#909590)

Step 5.1

Bag AE

M19	7x13x0.1mm
M20	7x13x0.3mm
M21	7x13x0.5mm

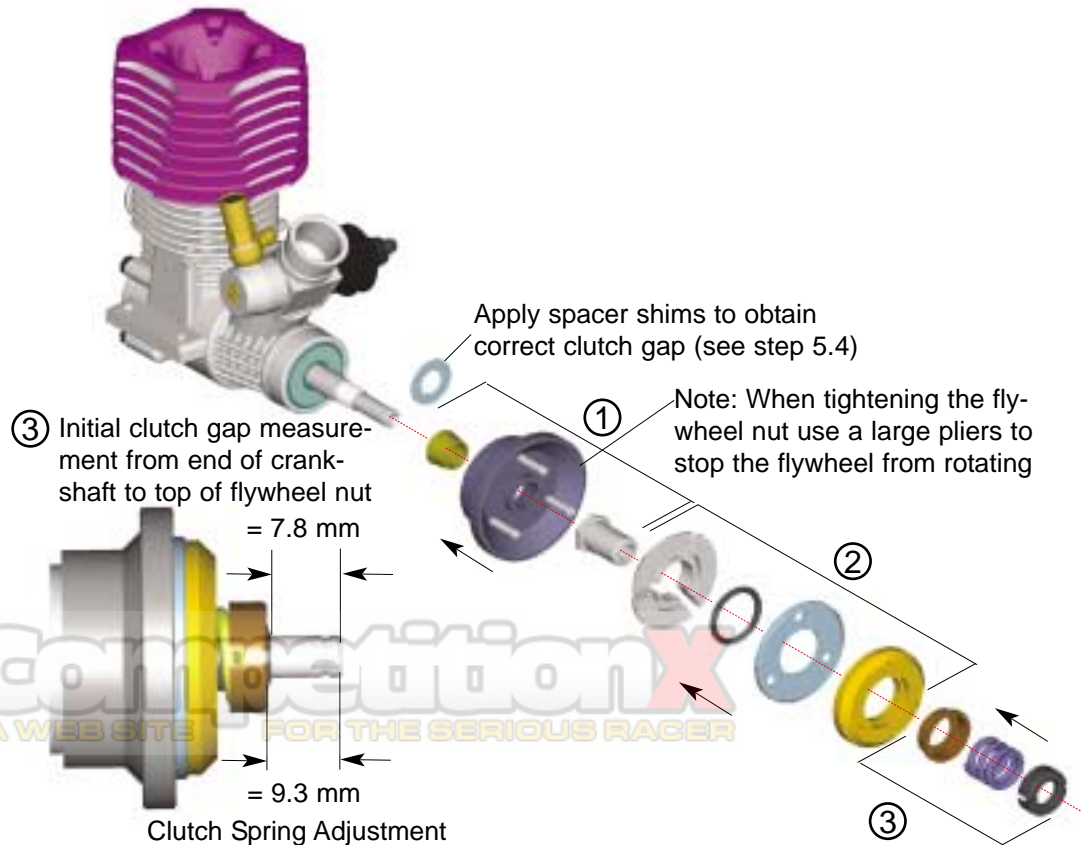

Step 5.2

F12 3x10mm

Note: It's important to lubricate this bearing regularly with some light oil.

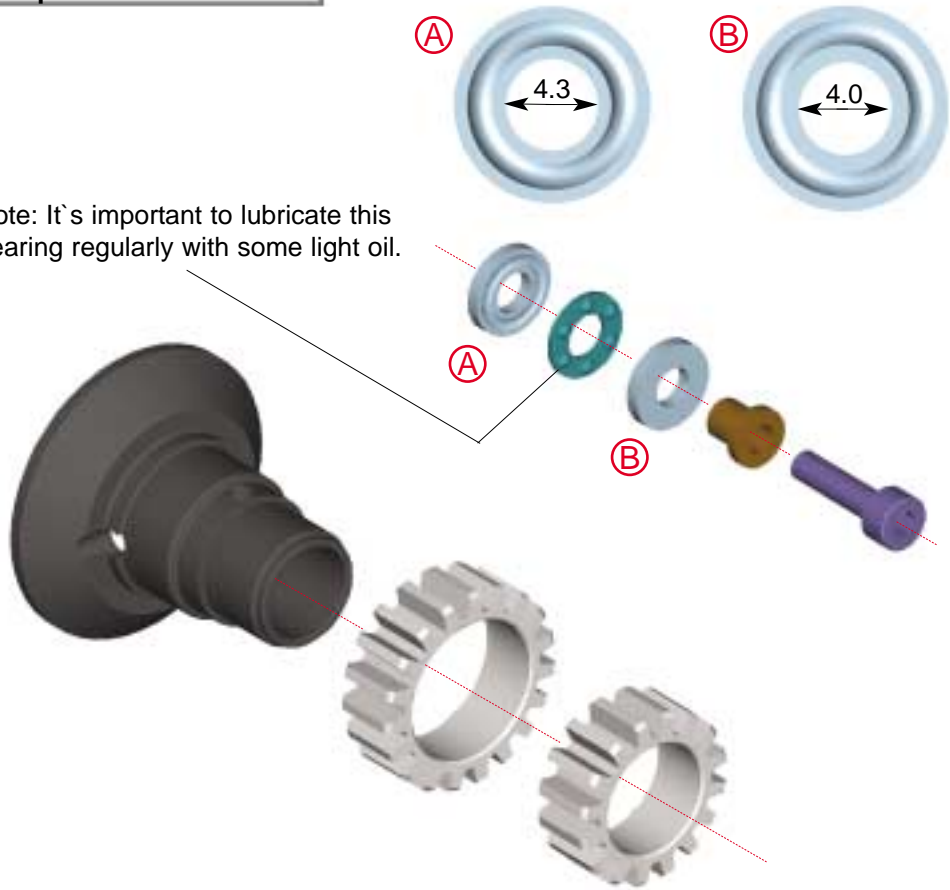

Step 5.3

V3 5x8mm

Insert the flanged ballbearing V3 into the end of the clutch housing.
Do NOT insert the inner ballbearing 5x10 (U4) yet as this ballbearing is left out to adjust the Centax clutch gap.
Place the clutch housing over the crankshaft and apply the thrust-bearing package.
Thread screw F12 all the way in.

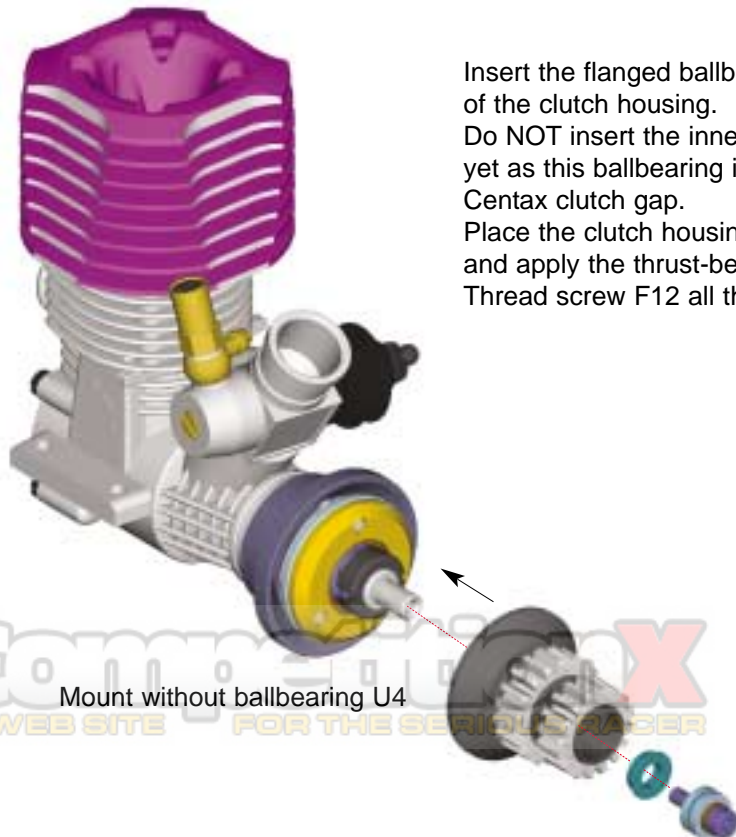

Mount without ballbearing U4

Step 5.4

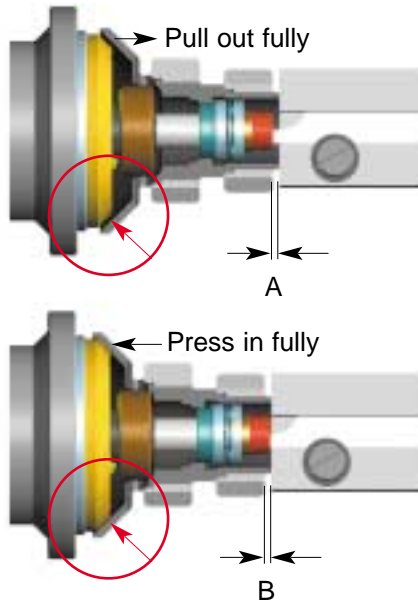

Adjusting the Clutch Gap

Pull the clutch shoe out and measure the distance between the outer edge of the clutch housing and the top of the socket head screw.

This is measurement **A**

Push the clutch housing towards the clutch shoe and measure the distance between the outer edge of the clutch housing and the top of the socket head screw again.

This is measurement **B**

Calculate the shim thickness as follows:

Shim thickness = (A - B - 0.6)

For example: A = 1.2mm and B = 0.3mm

Shim thickness = 1.2 - 0.3 - 0.6 = 0.3mm

Select shims to make up the correct shim thickness (in this example 1 of 0.1mm (M19) and 1 of 0.3mm (M20)).

Refer to Step 5.1 on how to insert spacer shims.

Step 5.5

-  M11 5x8x0.1mm
-  M11 5x8x0.3mm
-  U4 5x10mm



With the inside clutch housing bearing (U14) mounted, pull the clutch housing out and measure the distance between the edge of the clutch housing and the top of the socket head screw.

This is measurement **C**

Push the clutch housing in and measure the distance between the edge of the clutch and the top of the socket head screw.

This is measurement **D**

Calculate shim size = (C - D - 0.1mm)

Remove the clutch housing. Apply shims (M11 - M12) with a total thickness as determined by the calculation. Re-mount the clutch housing



Apply spacer shims to obtain correct end play



6.0 GEARBOX ASSEMBLY

For ease of assembly, use the Gear Gripper (#909595) in conjunction with the Nutwrench (#909596)

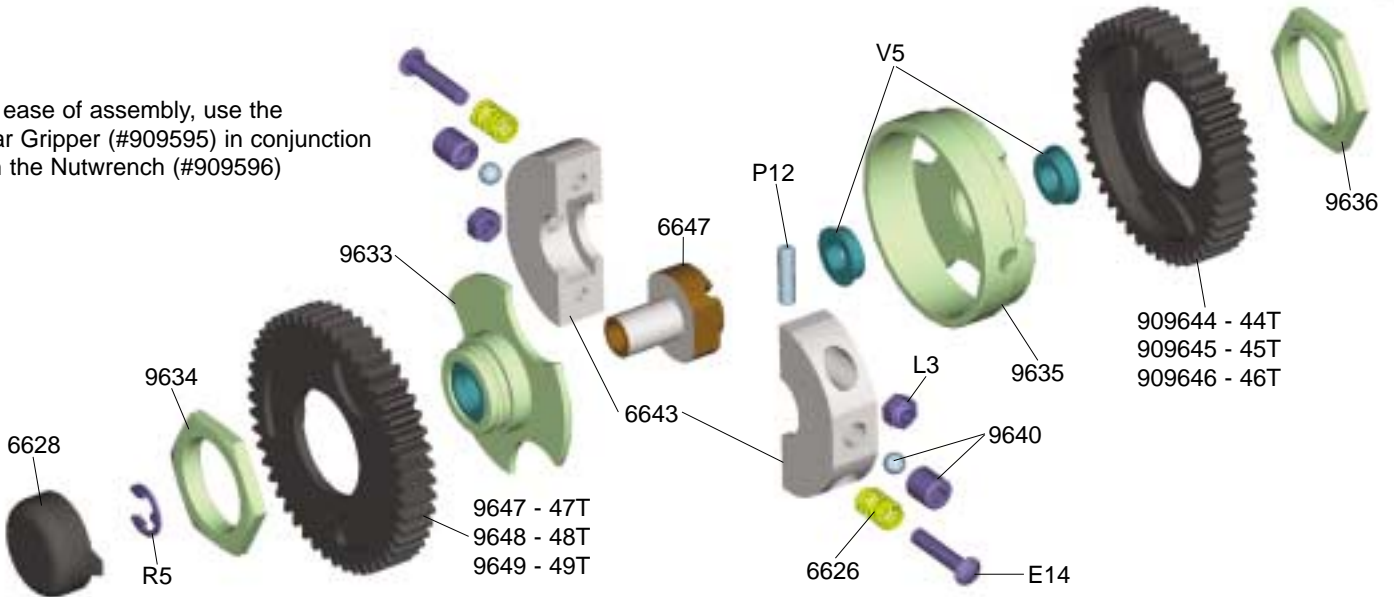

Step 6.1

Bag AF

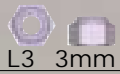
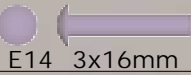

Note: Always screw the grub-screw and ball in evenly. When in place, screw in until the shoe touches the clutchbell and then bring back a 1/2 turn.

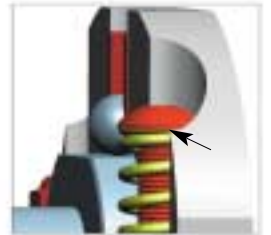
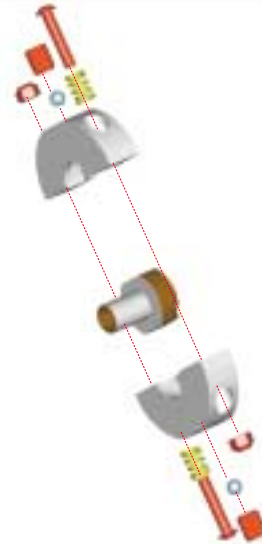

Note: A good starting point is when the head is flush with the side of the hole.

Step 6.2



V5 6x10mm



R5 5mm

P12 3x12mm



(A) Counter, clockwise thread, marked with little groove.



(B) Clockwise thread



Final Adjustment of the Gearbox shifting point is made when at the track. Turning the E14 screws in will give a later shifting point, turning them out will give an earlier shifting point.

7.0 FINAL ASSEMBLY

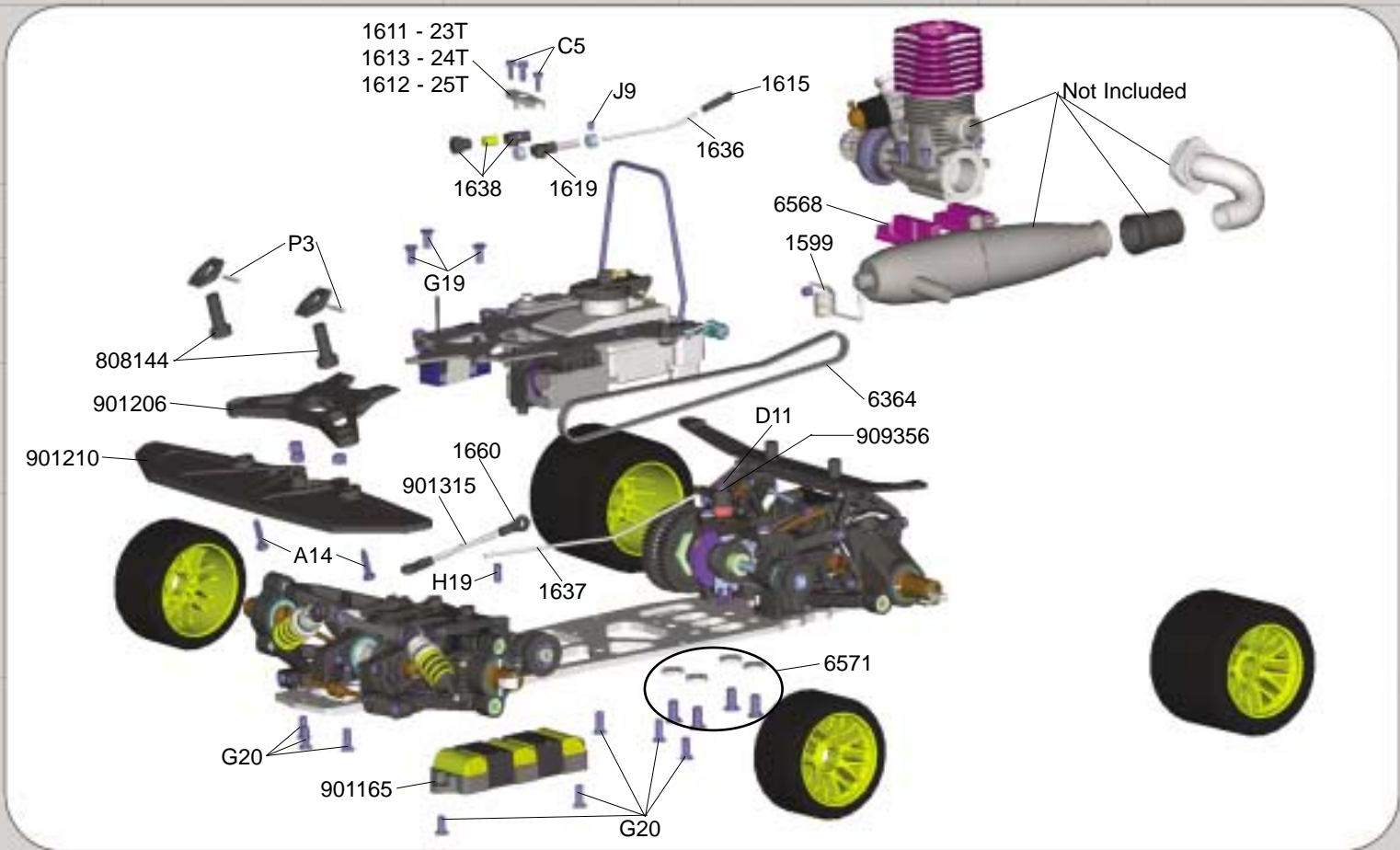

Step 7.1

Bag AG

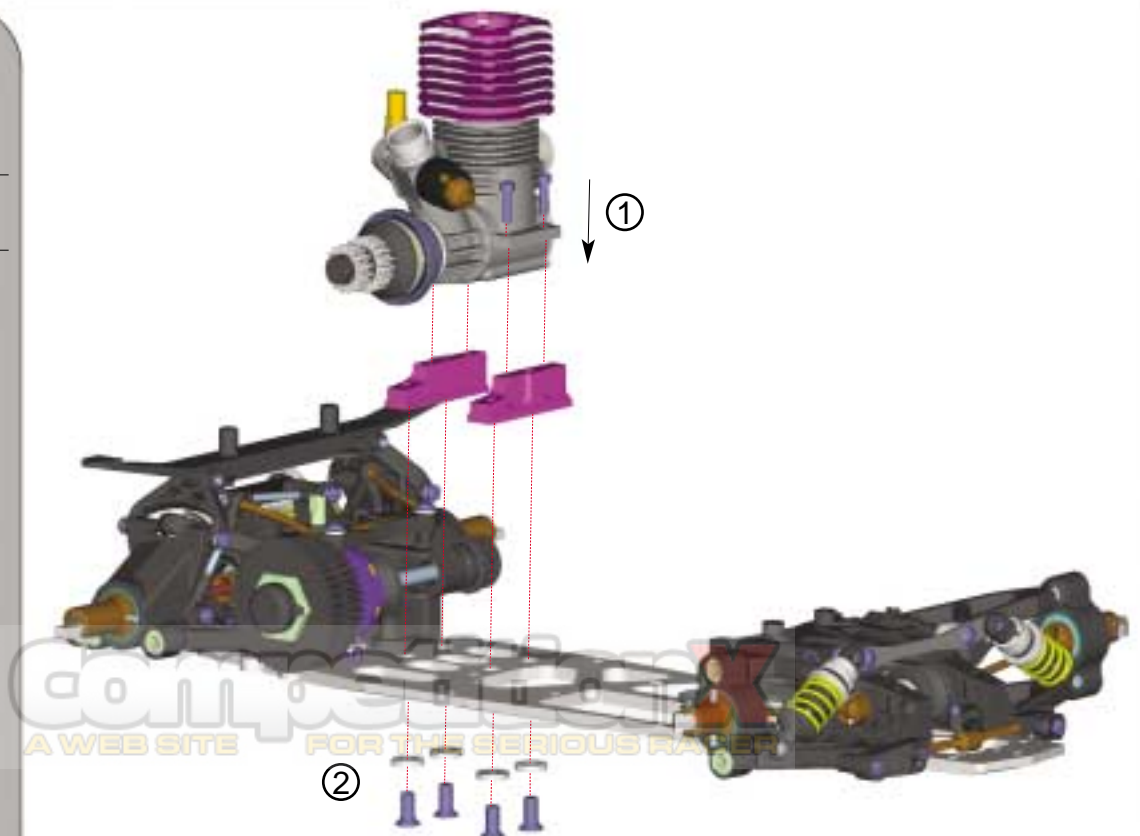

Step 7.2

Bag AH,AI,AK,G20

G20 4x12mm

D11 3x8mm

A14 3.5x16mm

P3 2x14mm

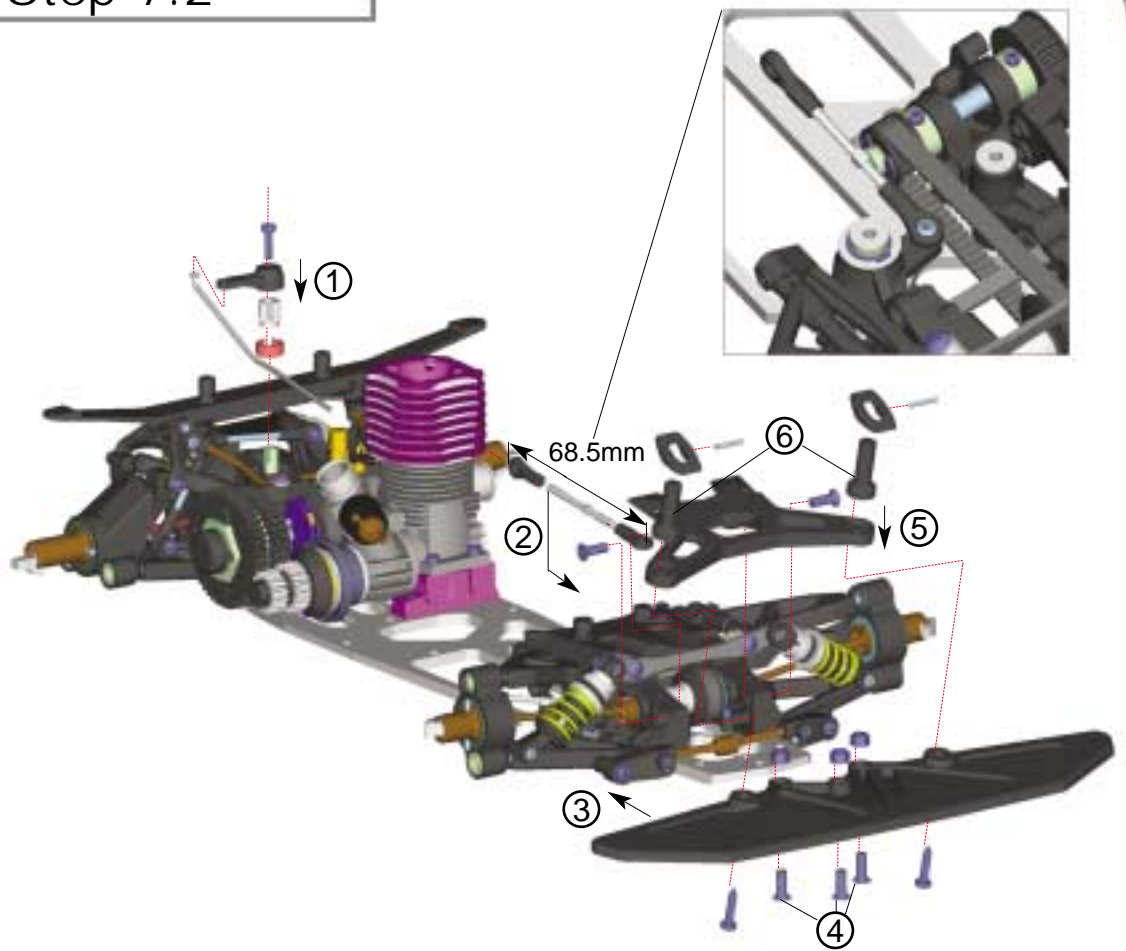

Step 7.3

Bag AL,G19,G20

G20 4x12mm

G19 4x10mm

C5 2.5x8mm

H9 3x4mm

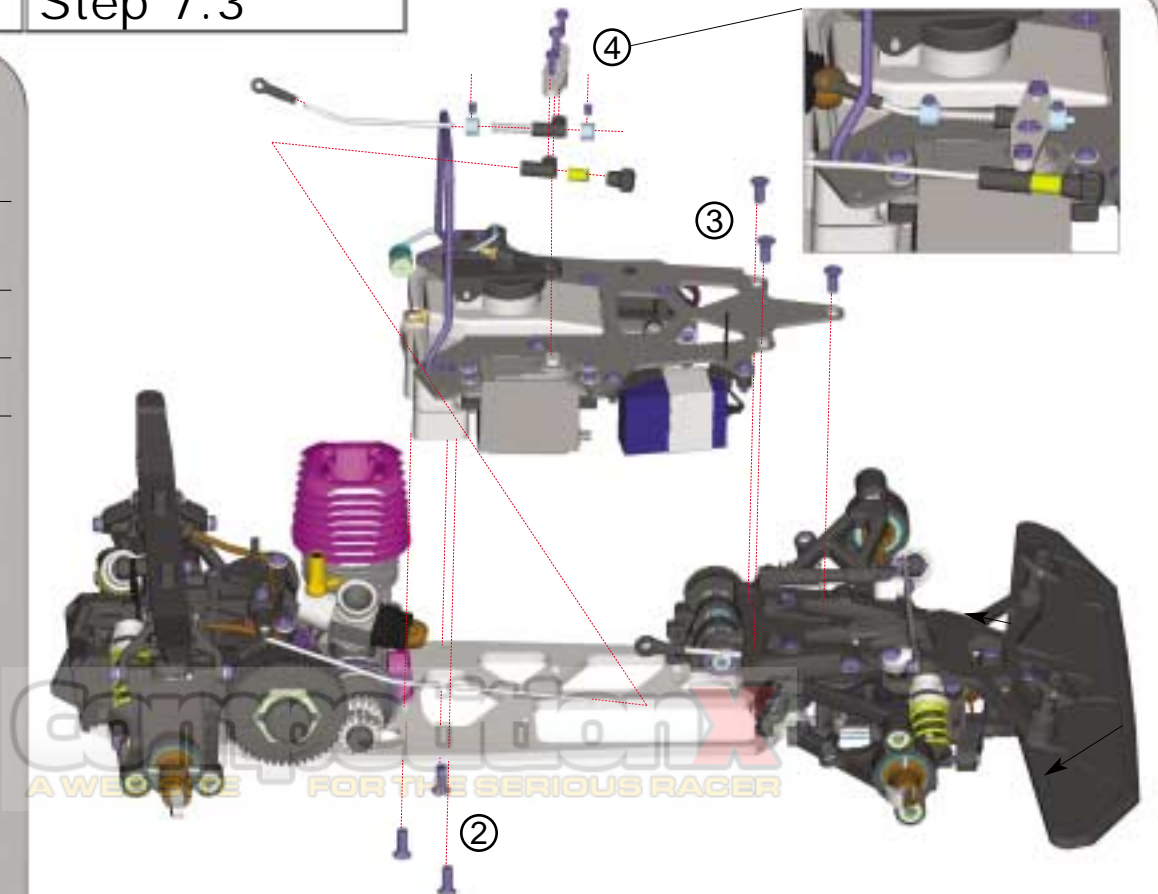

Step 7.4

Bag AM

H19 4x10mm

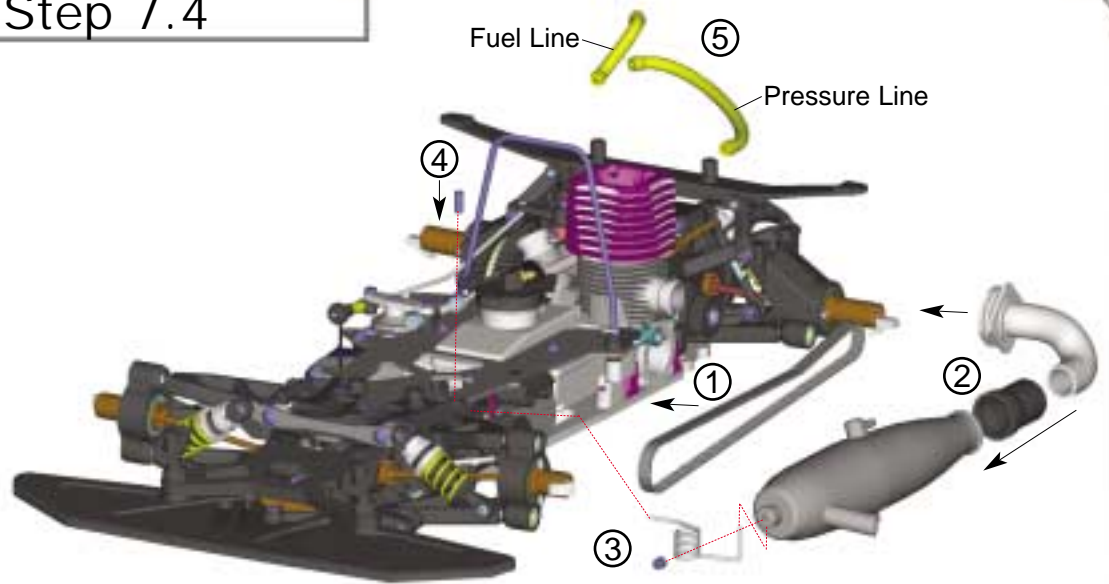

Step 7.5

Bag G20

G20 4x12mm

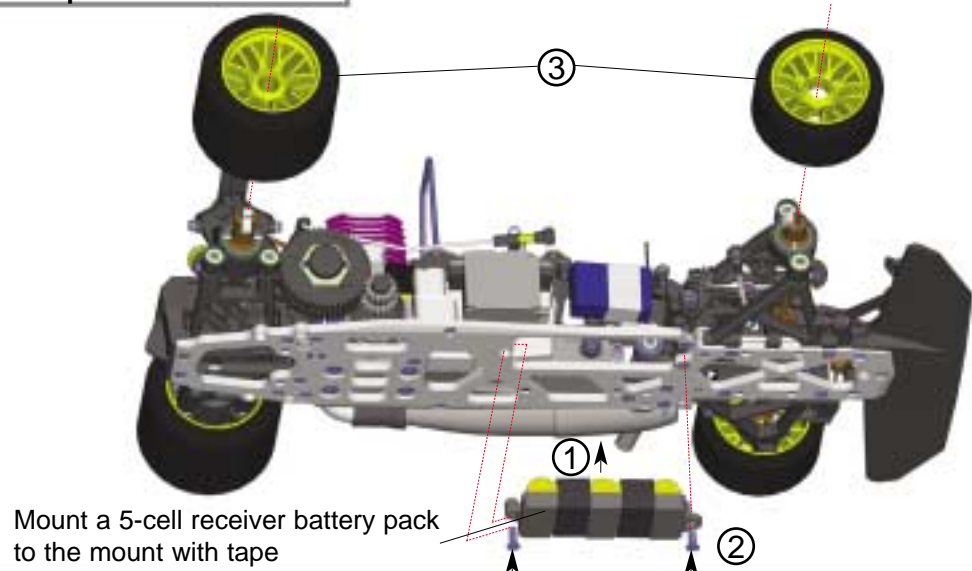

Step 7.6

