

EXCEL

9000 SERIES

SERPENT, THE MARK OF EXCELLENCE

ASSEMBLING INSTRUCTIONS



EXCEL **9000 SERIES**

SERPENT, THE MARK OF EXCELLENCE

ASSEMBLING INSTRUCTIONS



ASSEMBLING THE FRONT SUSPENSION

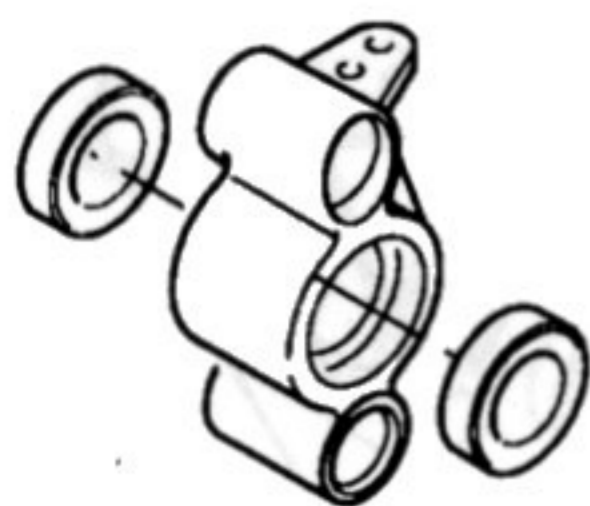

Right and left front suspension assemblies are very much the same. Shown is the left side, follow the same instructions for the right side.

Press the 2 ballbearings in the steering block.



Insert the front wheelaxle and apply the nylon washer on the outside with the flat side of the washer facing to the outside.



Place the nylon lever in the wheelaxle and press the steel 2.5mm pin through the hole. The lever pivots around the pin. Apply the torsion spring, the 2 legs snap behind the small edge inside the wheelaxle. Check that the axle turns freely with a minimal sideplay.

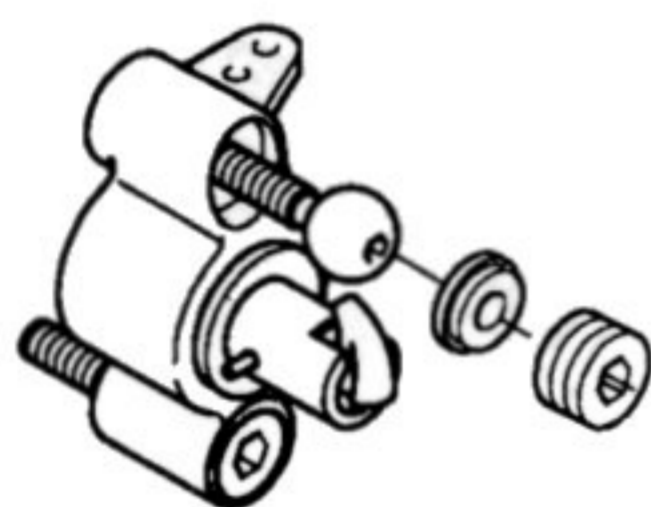

Insert the 2 pivot balls into the steering block. Apply the alu. M12 nuts and the large nylon ball cups and carefully adjust the play and the free movement of the balls in the steering blocks.

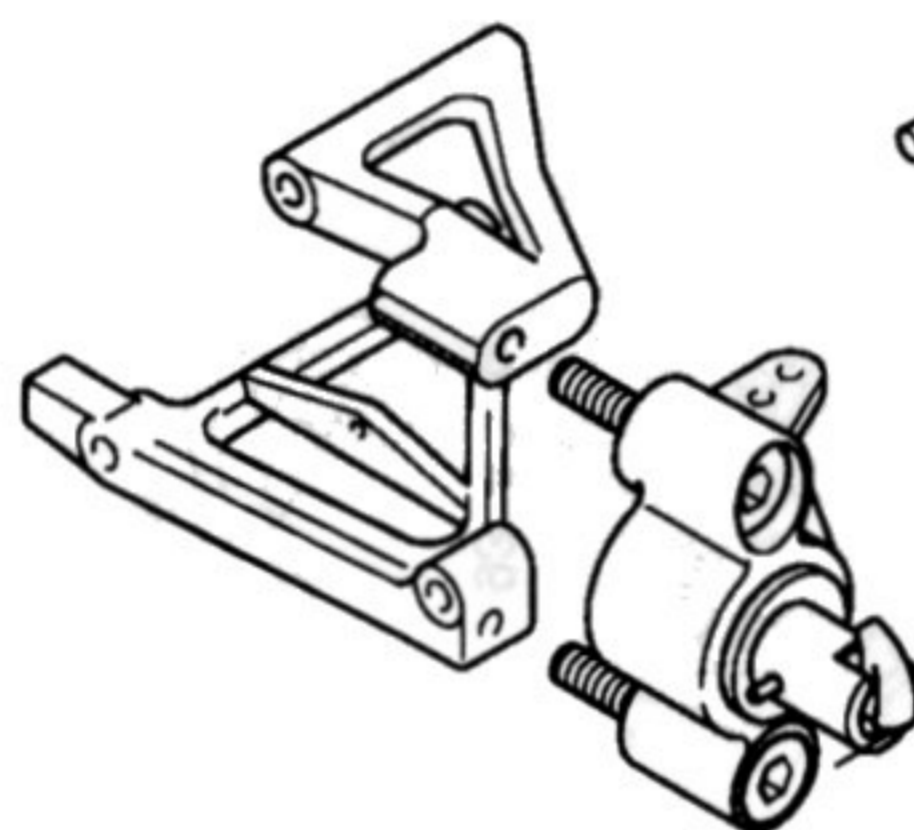

The M5 threaded parts of the pivot balls are turned into the threaded holes of the suspension arms. Note that the holes are slightly angled backwards.

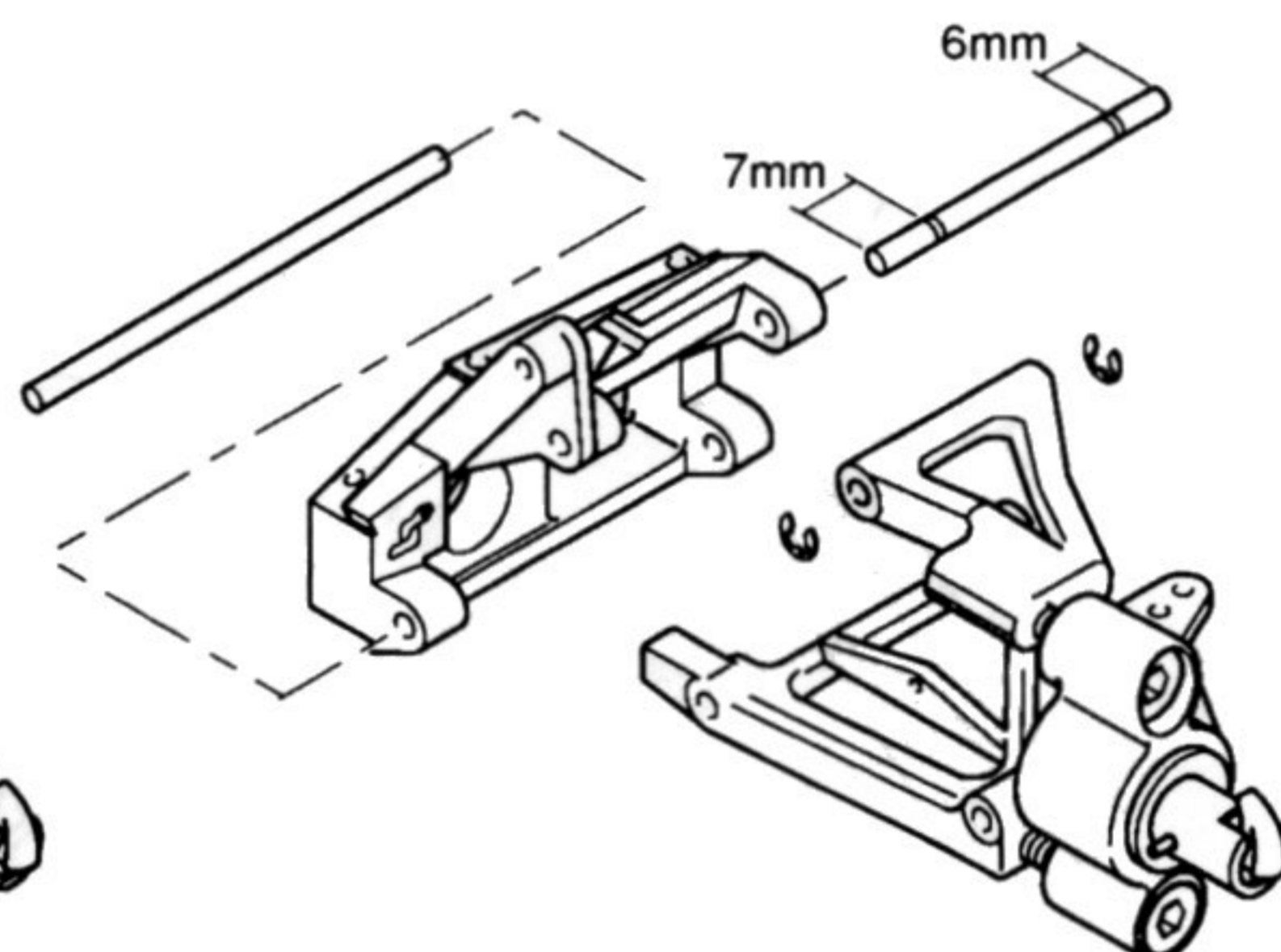

Because of the injection molding process, the lower and upper 4mm holes may require some alignment, check with the pivot pins. Position the suspension arms in the front bracket and insert the steel pivot pins (the longer part till the groove pointing forwards). The upper pivot pin is kept in place with the 2 C-clips, and the M4x6 setscrew is used to adjust the caster angle. Position the upper arm with a 2mm gap in the front. The lower pin is fixed with the M4x6 set-screw.

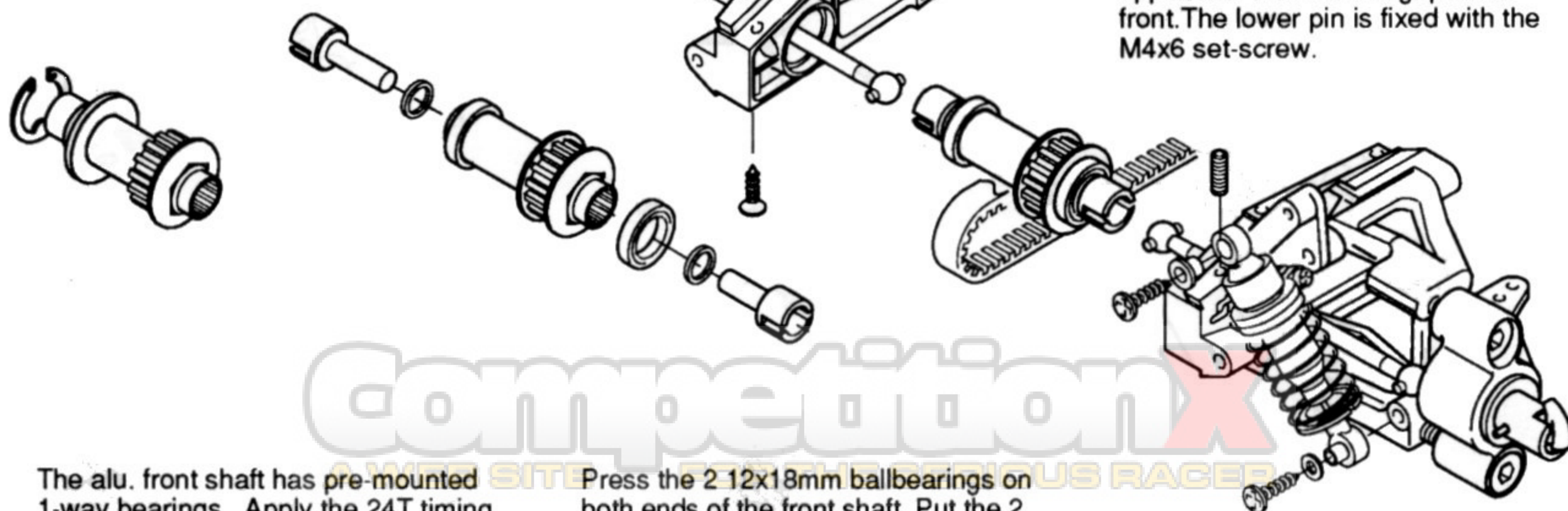

The alu. front shaft has pre-mounted 1-way bearings. Apply the 24T timing belt pulley and the nylon washer, and secure it with the circlips.

Press the 2 12x18mm ballbearings on both ends of the front shaft. Put the 2 nylon spacers on the inner driveshaft adapters and place them in the front shaft. Put the front shaft with the front drive shafts in place, and the long timing belt, and screw both front brackets to the chassis using c.s.h. screws 3.5x13.

Screw the 2 M4x10 setscrews in the front brackets, to adjust the ride-height. The adjustment and setting-up of the front suspension is explained under "SETTING UP THE SERPENT EXCEL".

Competition X
A WEB SITE FOR THE SERIOUS RACER

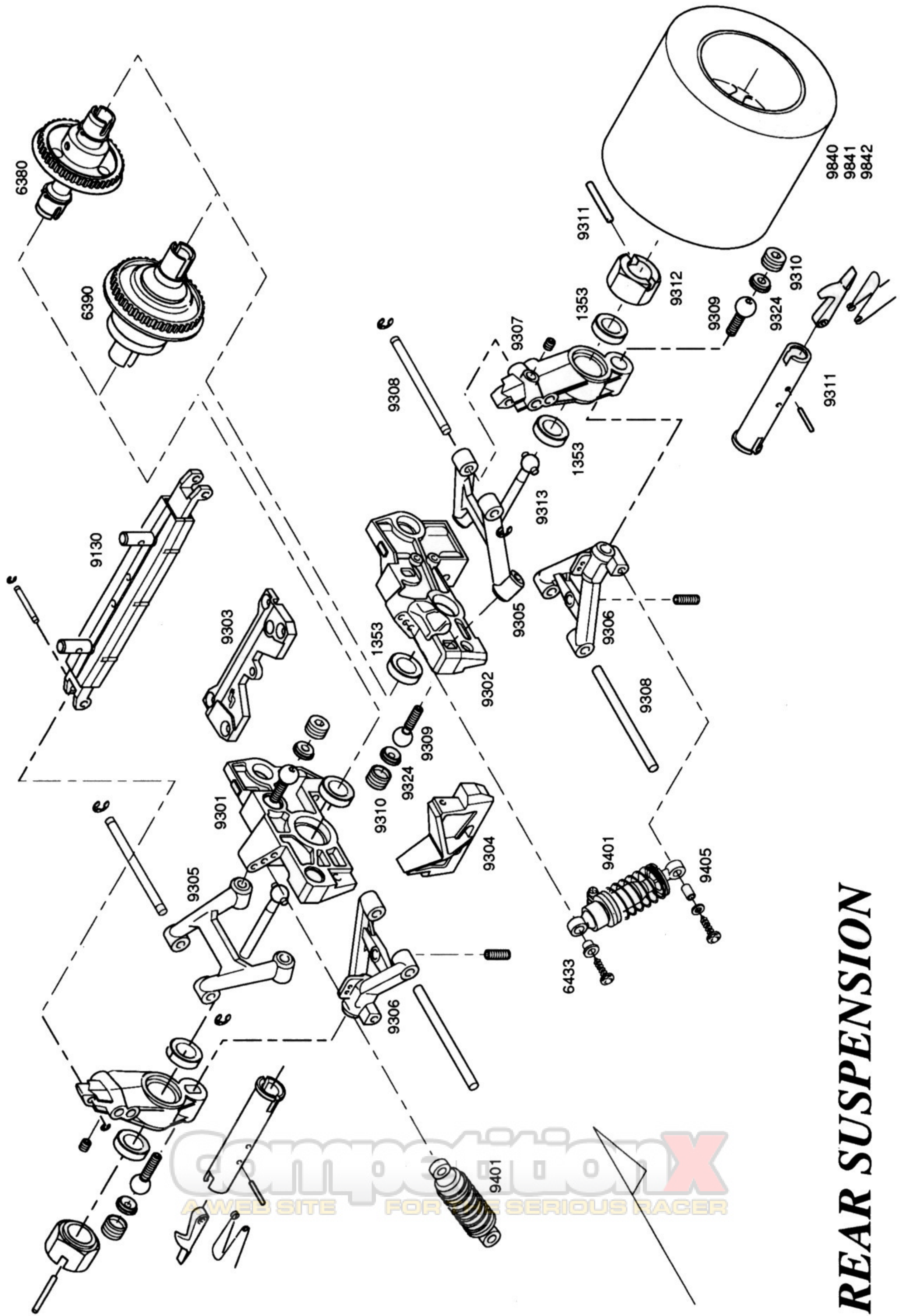

REAR SUSPENSION

CompetitionX
 A WEBSITE FOR THE SERIOUS RACER

ASSEMBLING THE REAR SUSPENSION

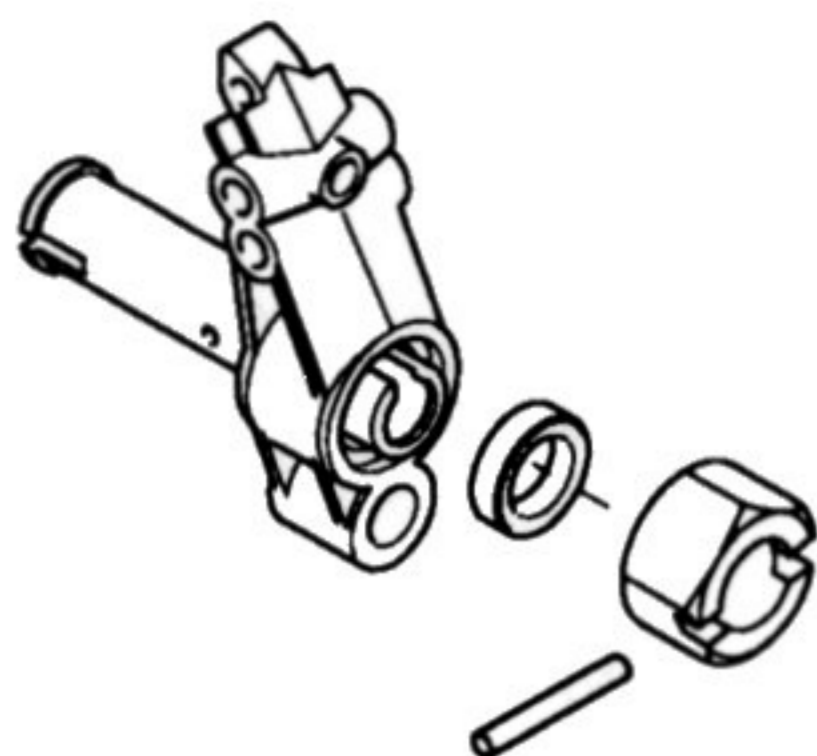

The right and left up-right are identical. Press the 2 12x18 ballbearings in the up-right. Insert the rear wheelaxle, apply the nylon hexagon rear wheeladapter and press the 2.5x20mm pin through the hole of the axle. Check the free turning, and a minimal side-play.

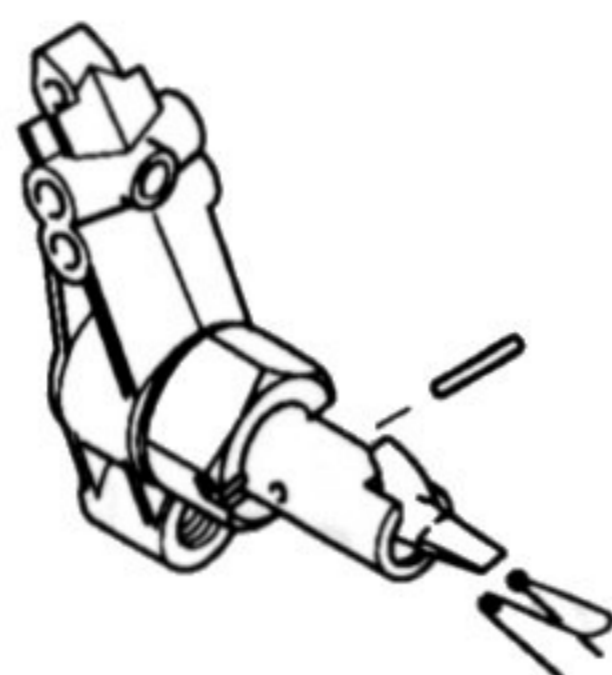

Place the nylon lever in the rear wheelaxle and press the 2.5x12mm pin through the second hole and the hole of the lever. Apply the torsion spring, the 2 legs of the spring snap behind the small edge on the end of the axle, just like in the front wheel axles.

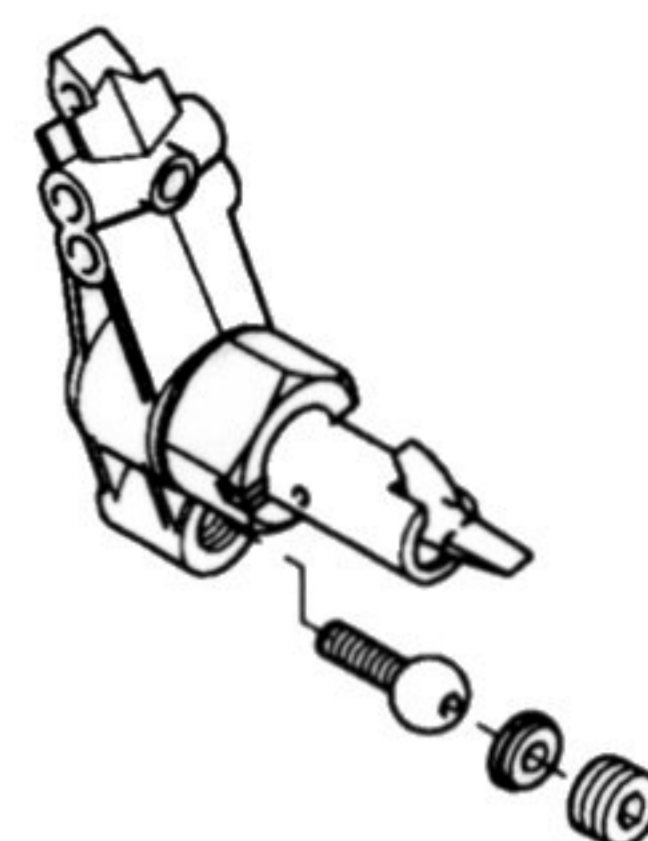

Insert the 8.5mm pivot-ball (of which the thread is not turned away) and screw the alu. M10 adjusting nut in the threaded hole of the up-right with the nylon ball cup in place. Carefully adjust the play and the free movement of the ball.

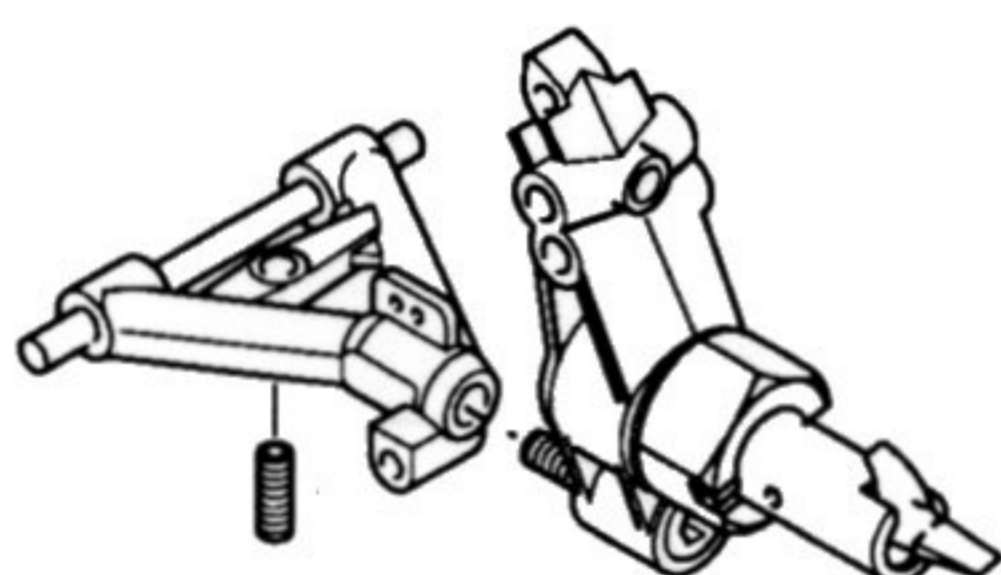

Screw the pivot ball in the lower suspension arm. Press the long steel pivot pin in place, equally protruding on both sides of the arm. Turn the M4x10 setscrew in the lower arm to adjust the ride-height.

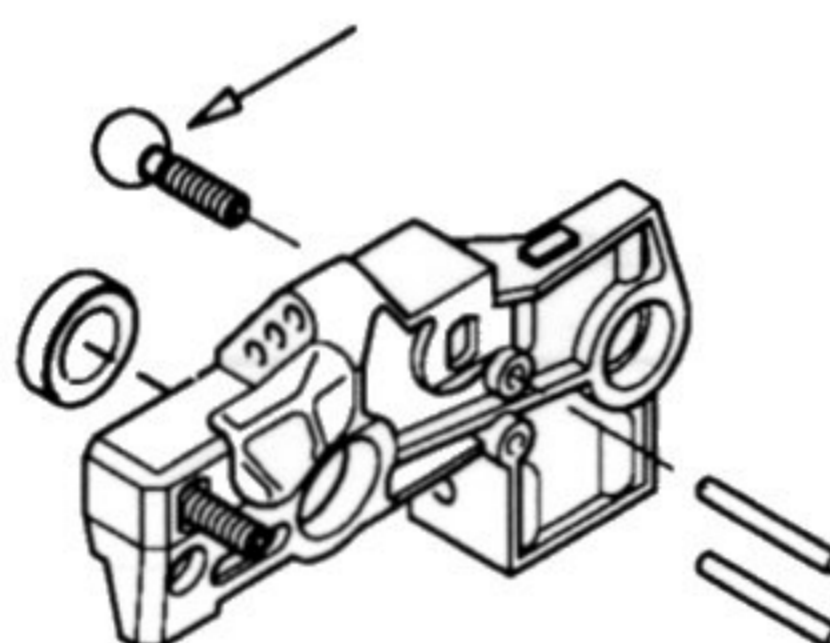

The 2 brake roll-pins (2.5x24) are pressed into the right side bearing block. Place the 8.5mm pivot balls in the bearing blocks (use the pivot balls of which the thread is turned away just behind the ball).

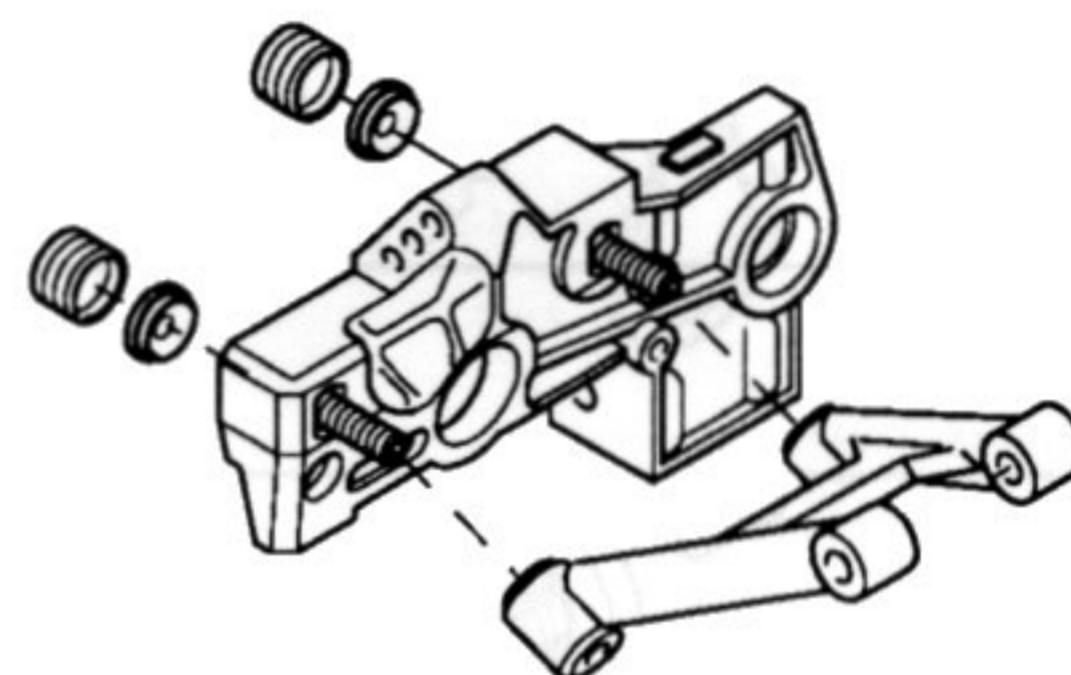

The upper suspension arms are attached. The arms are marked L and R. Turn the pivot balls into the threaded holes of the suspension arms. Insert the alu. M10 adjusting nuts and the nylon ball cups and carefully adjust the free movement and the play of the balls.

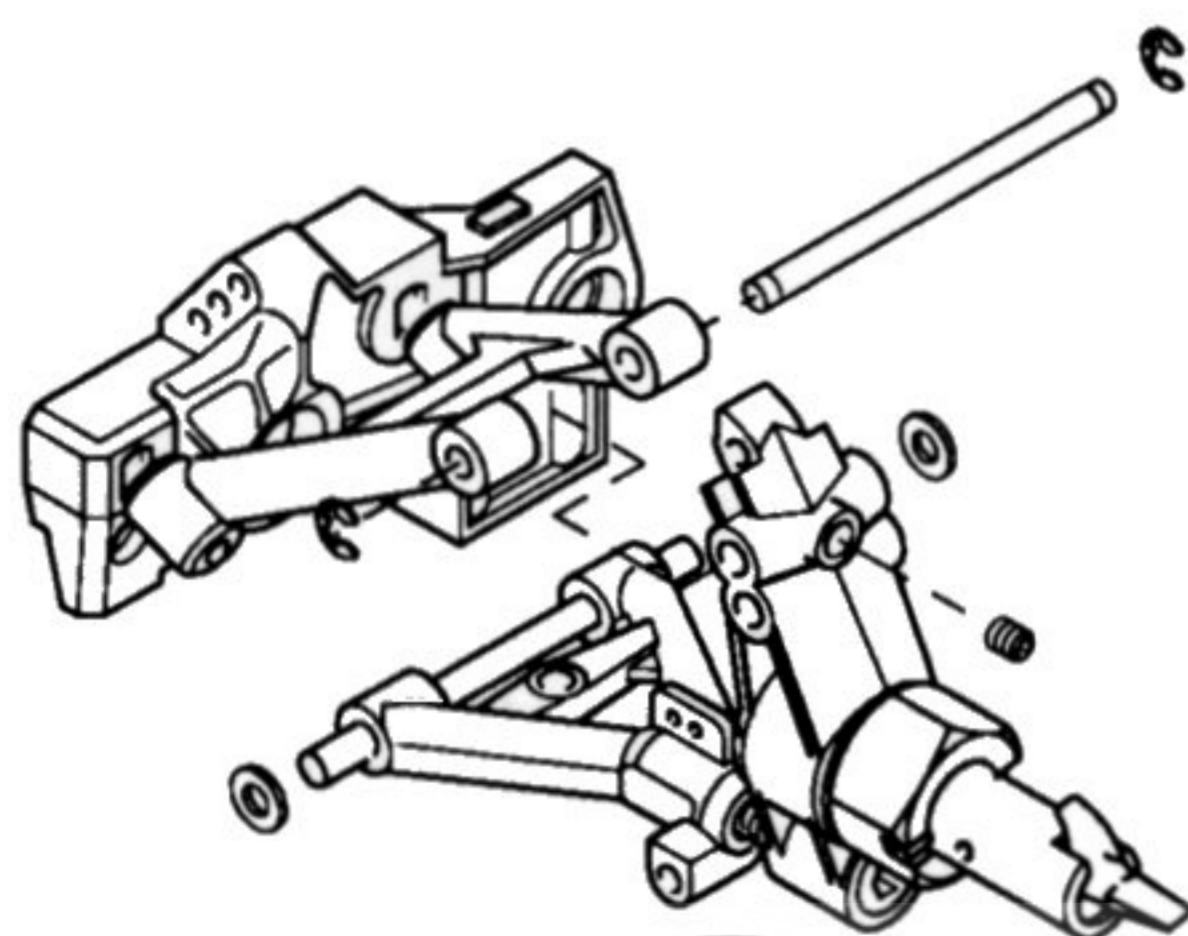

Attach the assembled lower arm and up-right. Use the upper hole in the up-right. The lower hole gives an alternative camber change. The pin is secured with the setscrew M4x4 and with the 2 3.2mm C-clips on both ends of the pivot pin. Use the 4mm shims to adjust any side-play.

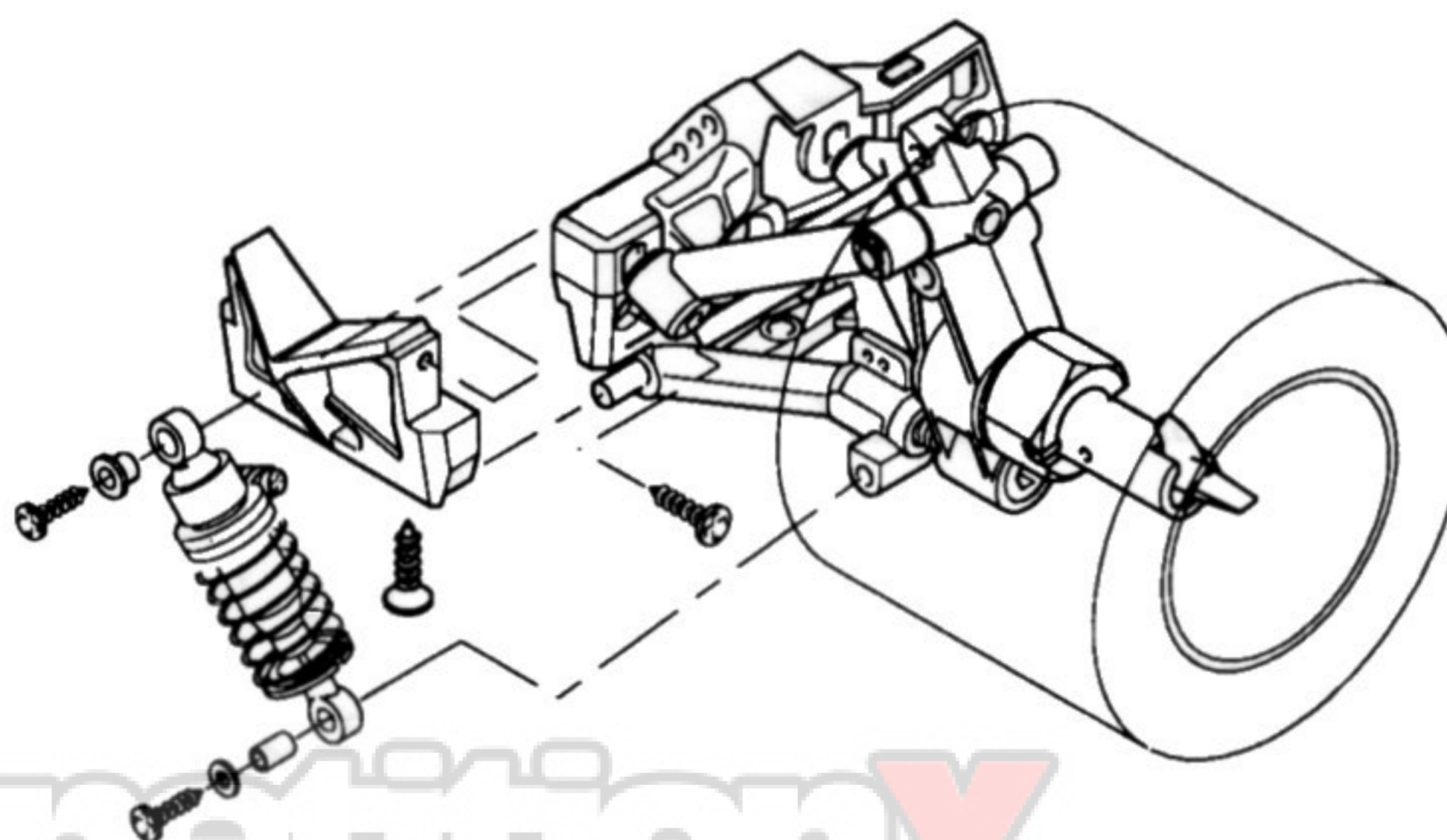

The rear plate is mounted to the diff. blocks with r.h. screws 3.5x13. After completion of the differential or the solid axle, the whole rear end is mounted to the chassis using 6 c.s.h. screws 4.2x13.

The rear shocks are mounted using the small nylon pivot bushing in the top and the chromed 4mm bushing in the bottom. Use r.h. screws 2.9x13. The adjustment and setting-up of therear suspension is explained under "SETTING UP THE SERPENT EXCEL"

COMpetitionX
A WEB SITE FOR THE SERIOUS RACER

ASSEMBLING THE BALL DIFFERENTIAL

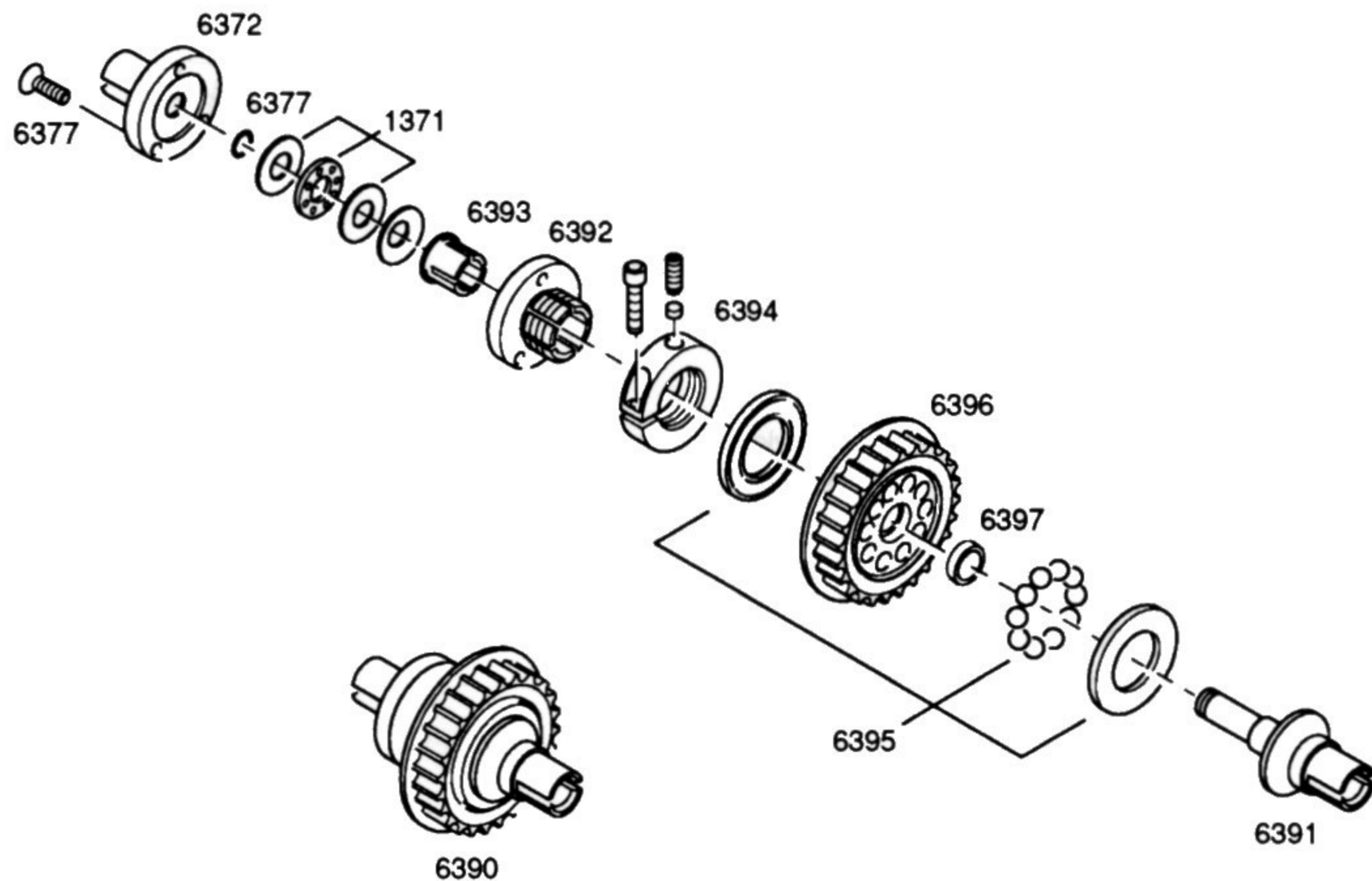

Press the nylon clamp bushing in the alu. diff. hub.

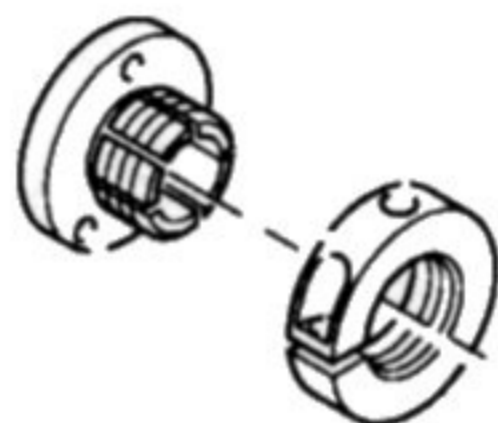

Turn the alu. adjusting nut on to the diff. hub, all the way back. Use some grease on the thread.



Remove the core from the 46T diff. pulley. Press the 8x12mm ballbearing in the pulley.

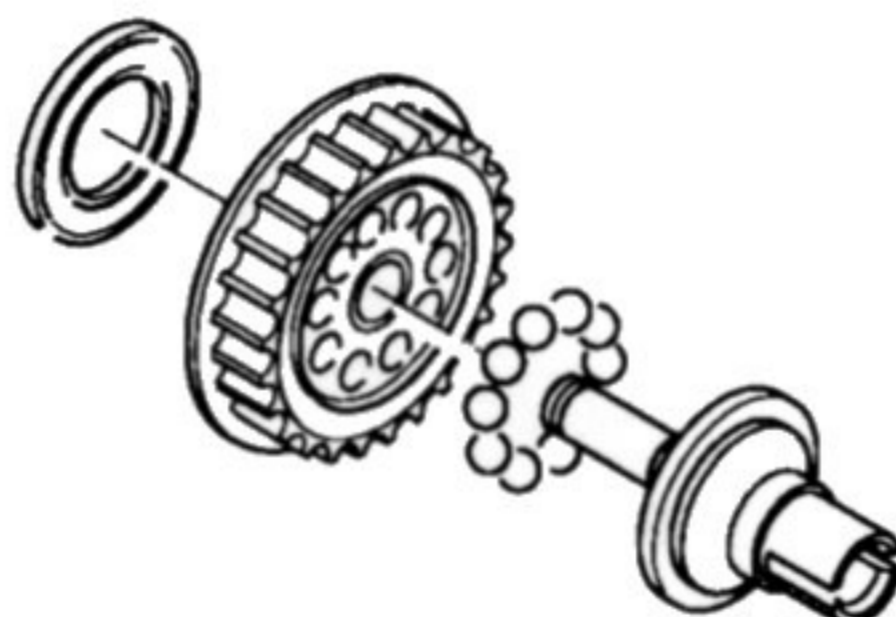

Place the grooved ring over the diff. axle, press the hardened steel balls in the pulley and apply the second grooved ring.

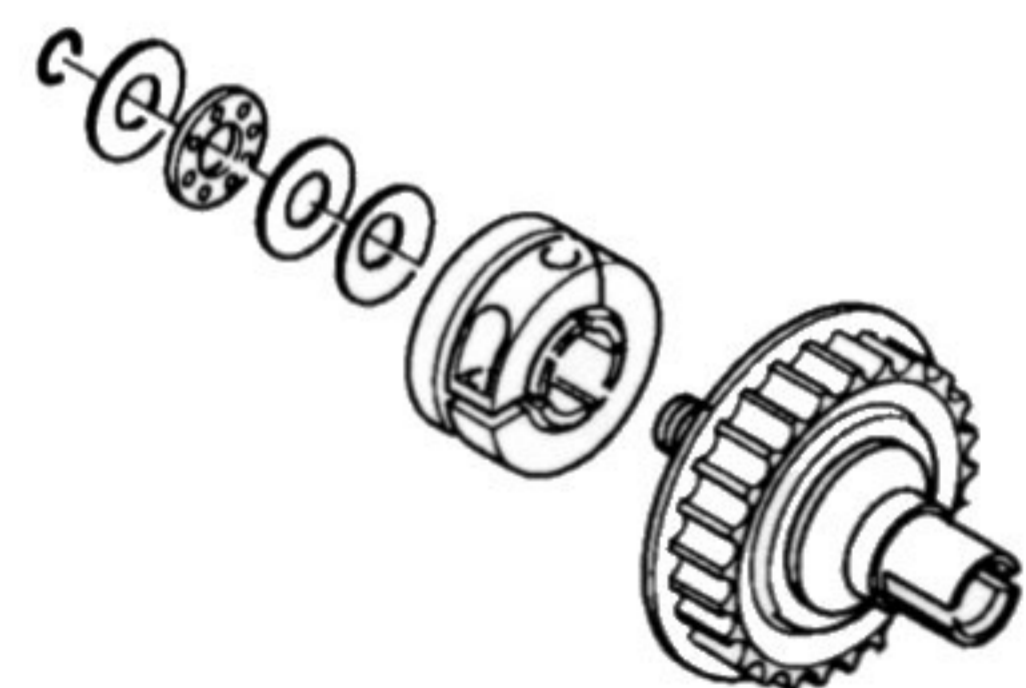

Place the diff. hub over the diff. axle and apply the bevel washer, followed by the 7mm thrust bearing and the clips. Turn the alu. adjusting nut towards the pulley, carefully pressing the clips in the groove of the diff. axle. Apply some load and check that the clips is well settled in the groove. Enough pre-load must be given to avoid the diff. to slip over the balls.

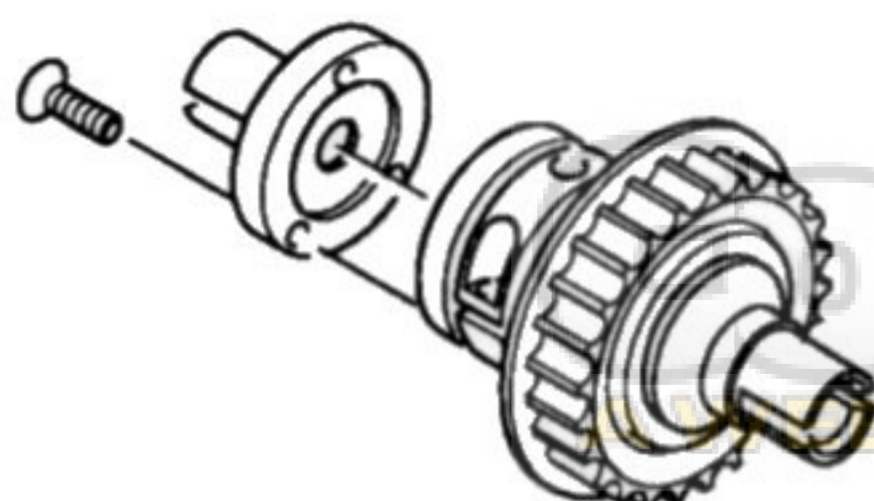

The diff flange is mounted with the 3 c.s.h. screws M3x8.

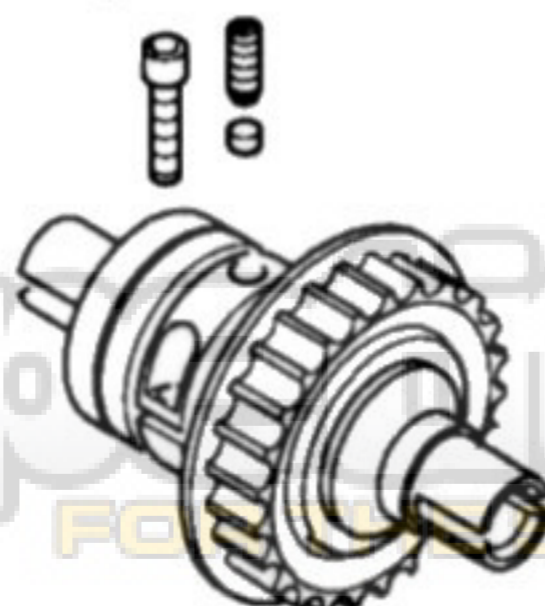

The alu. adjusting nut is locked with s.h. screw M3x12. The more load applied to the adjusting nut, the more resistance is created, giving more diff. lock. The setscrew M4x6 is used together with the nylon piece to secure the adjusting nut position.

More lock on the diff. will make the car turn in better, but will also make the car more nervous to drive. The fine adjustment must be made on the track.

ASSEMBLING THE 2-SPEED GEARBOX

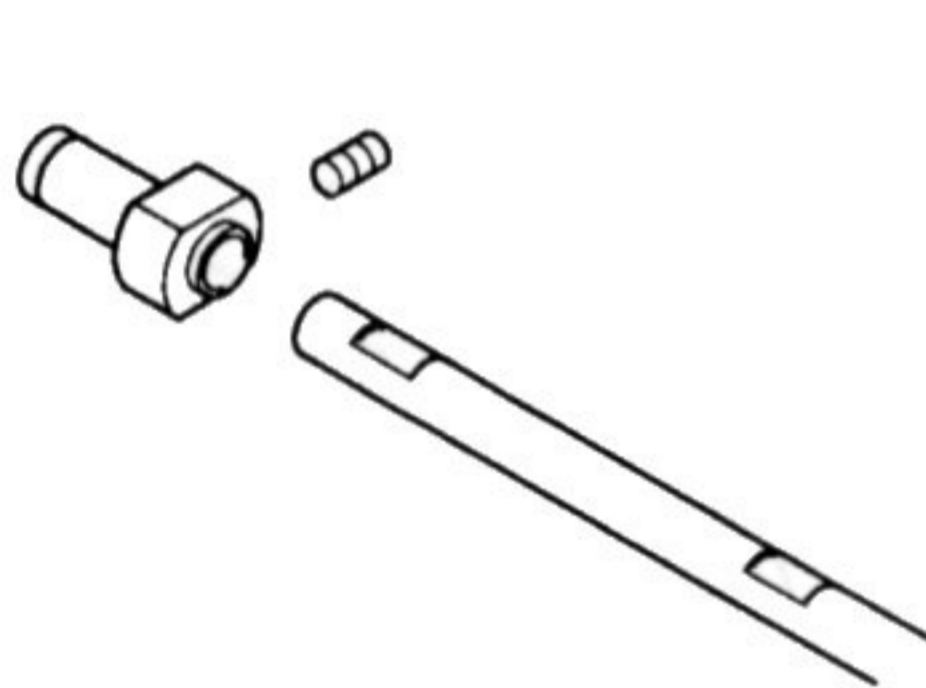
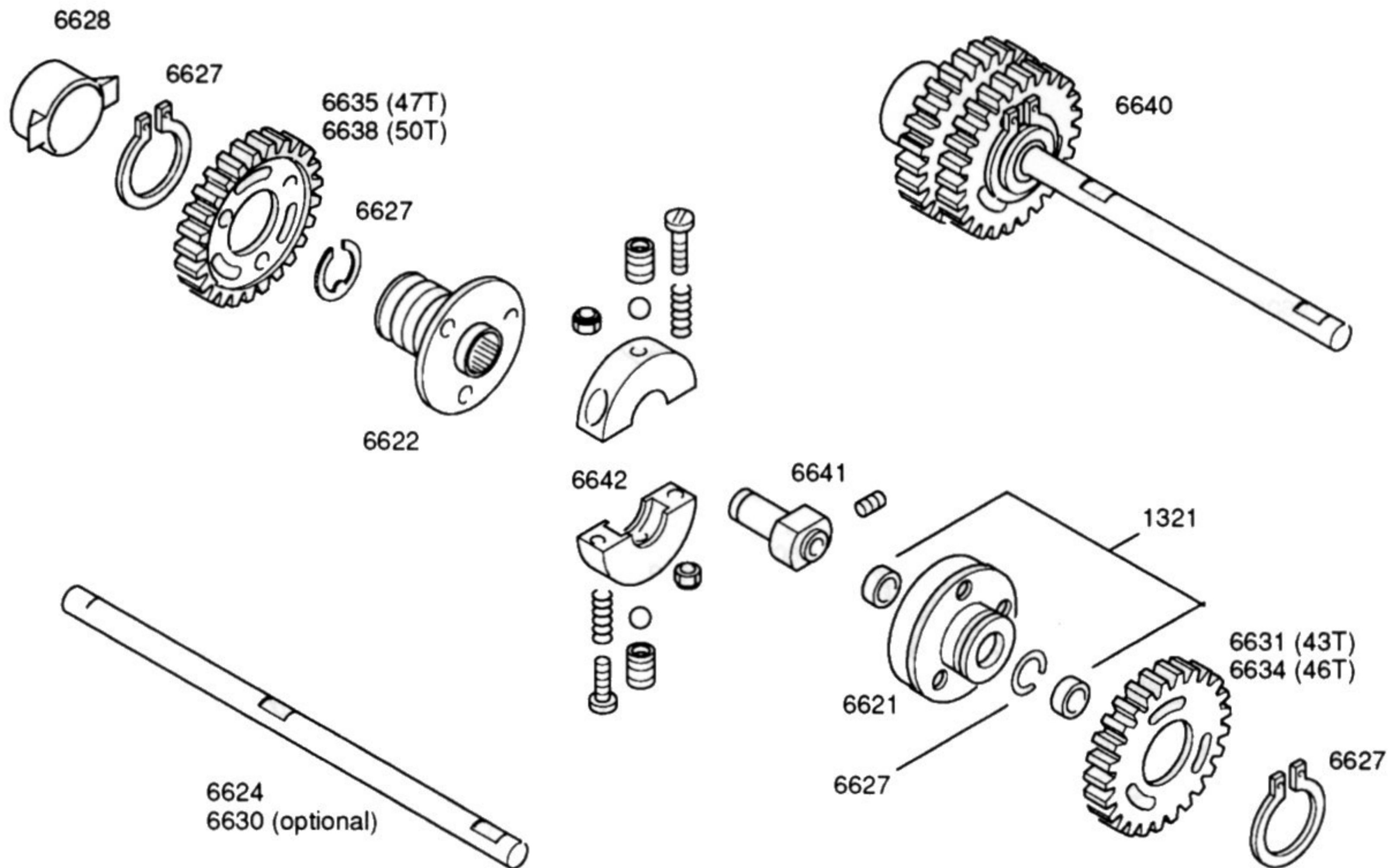

Mount the 2-speed adapter on the layshaft. Use some Lock-Tite to secure the M5x6 setscrew.

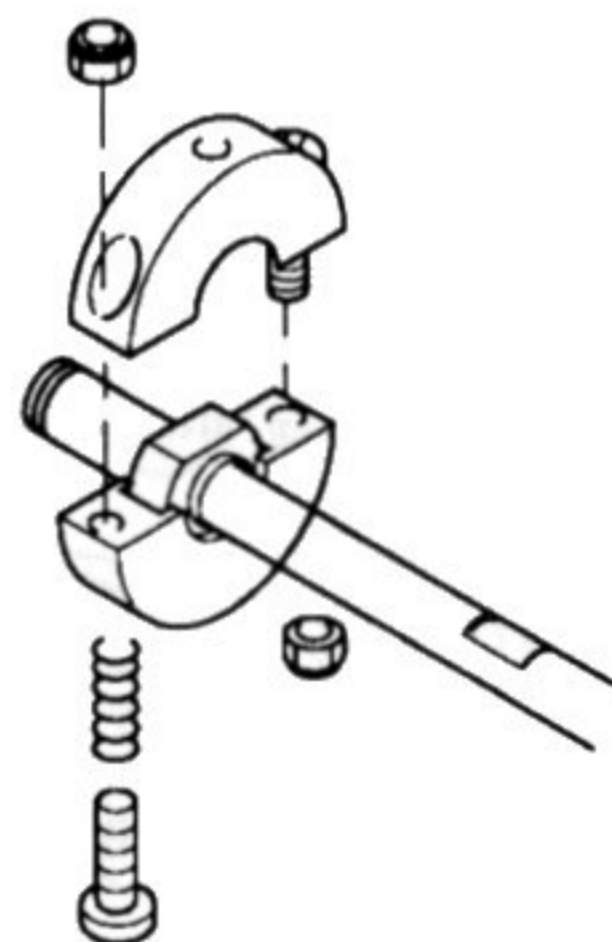

Apply the 2 clutch-shoes, using the 2 M3x16 screws, the coil-springs and the M3 lock-nuts. Turn both screws in equally far, so they protrude about 3mm (6 complete turns) through the nut. Applying more pre-load to these screws make the gearbox shift later.

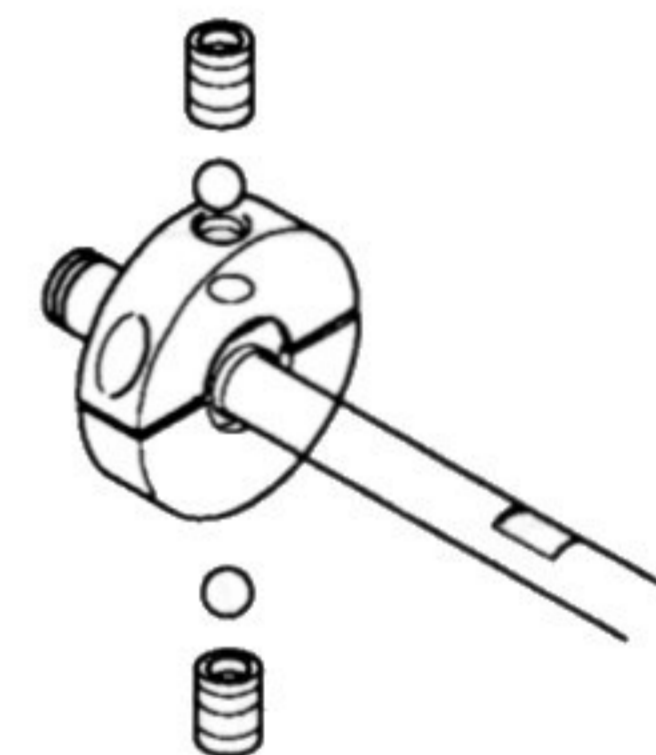

Turn the center adjusting screws in the shoes, with the 4mm balls in place. Make sure the balls press on the flat parts of the adapter. Adjust the center screws so that the shoes are just touching the clutch bell and then 1/4 of a turn back again.

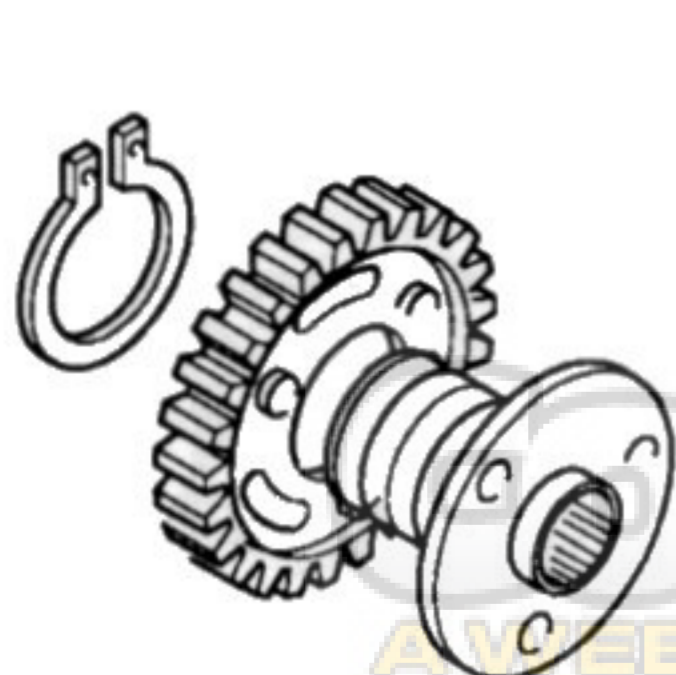

The 1-way bearing is pre-mounted in the drive flange. Place the 47T first gear on the drive flange and secure it with the large 19mm circlips.

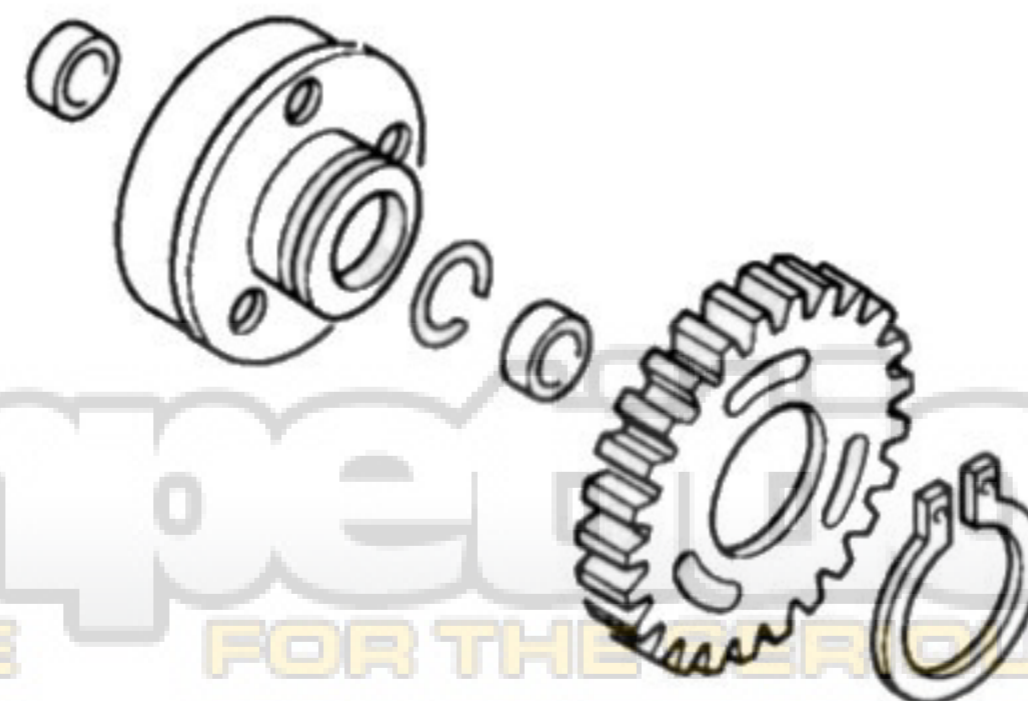

Insert the clips in the groove of the clutch bell and apply the 2 6x10mm ballbearings. Place the 43T second gear on the clutch bell and secure it with the large circlips.

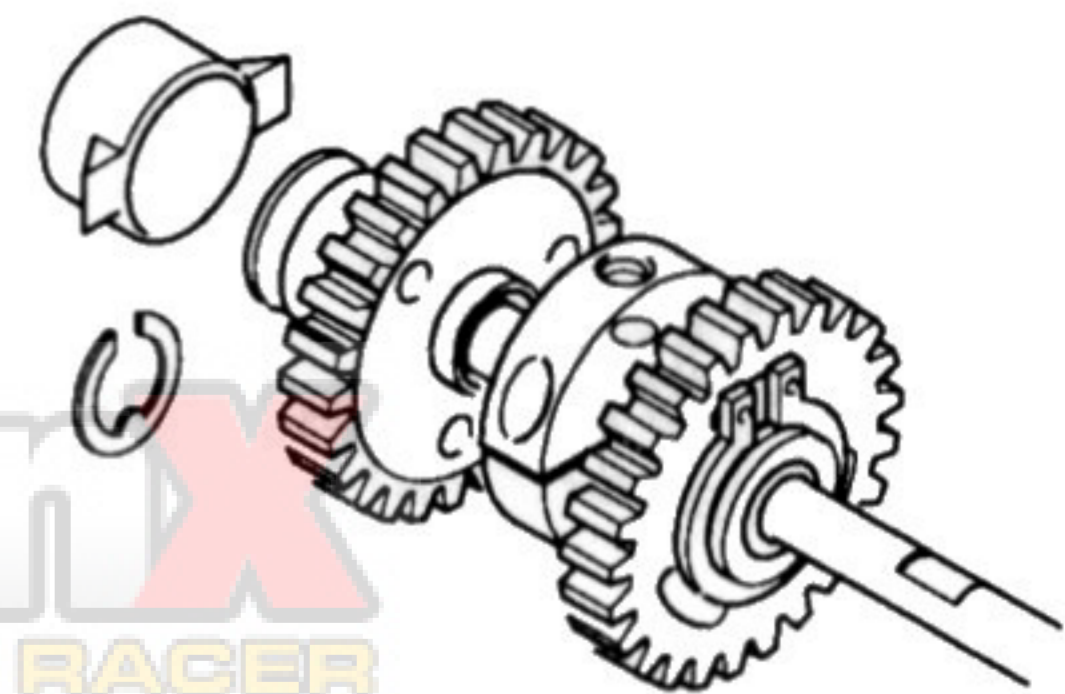

Now put all the pre-mounted parts together on the 2-speed layshaft. The drive flange is secured with the C-clips. The nylon dustcap is pressed on the drive flange to protect the 1-way bearing from dust and water.

ASSEMBLING THE DISK-BRAKE UNIT

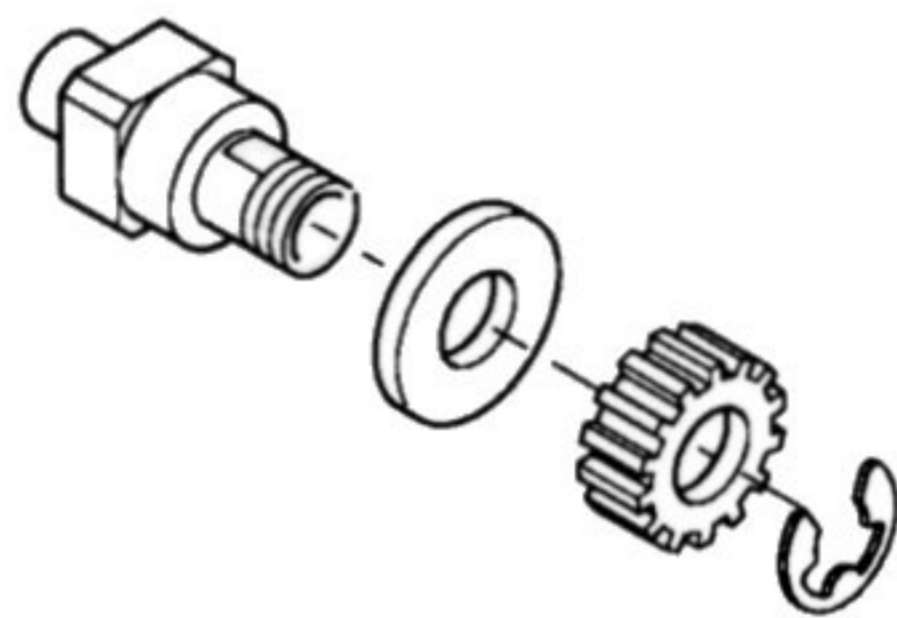
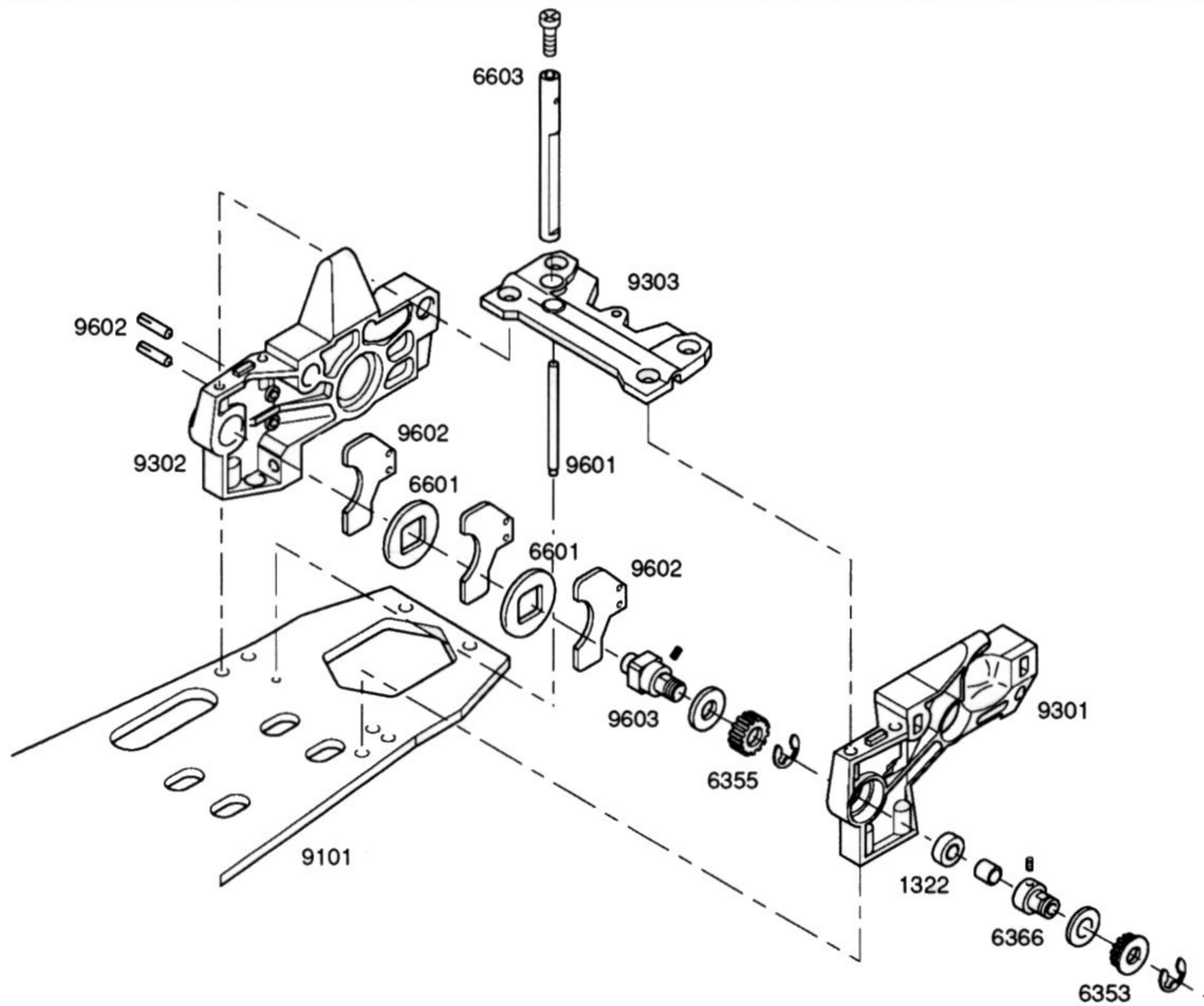

Press the 23T timing-belt pulley on the adapter, using some Lock-Tite or cyano-glue to fix the pulley firmly to the adapter. Secure it with the 7mm C-clips.

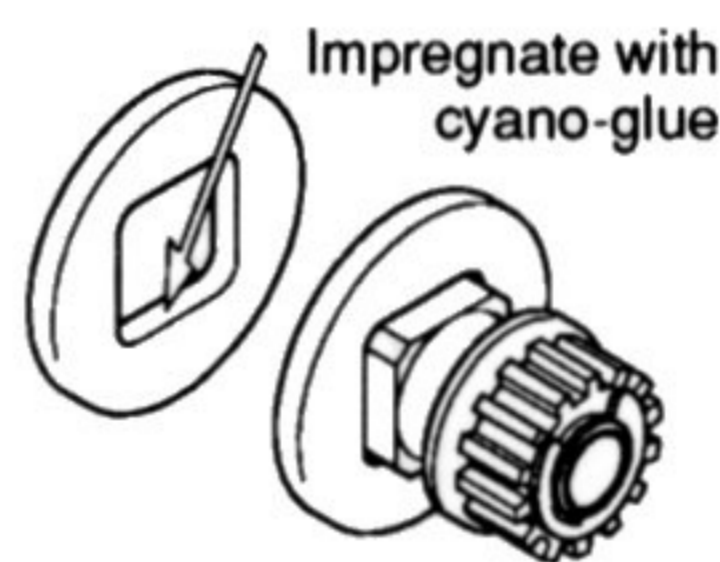

Check that the Ferodo brake disks move freely on the brake adapter square. It is advised to treat the inner square of the disks with some cyano-glue, this will reinforce the surface and extends the lifetime of the brake disks.

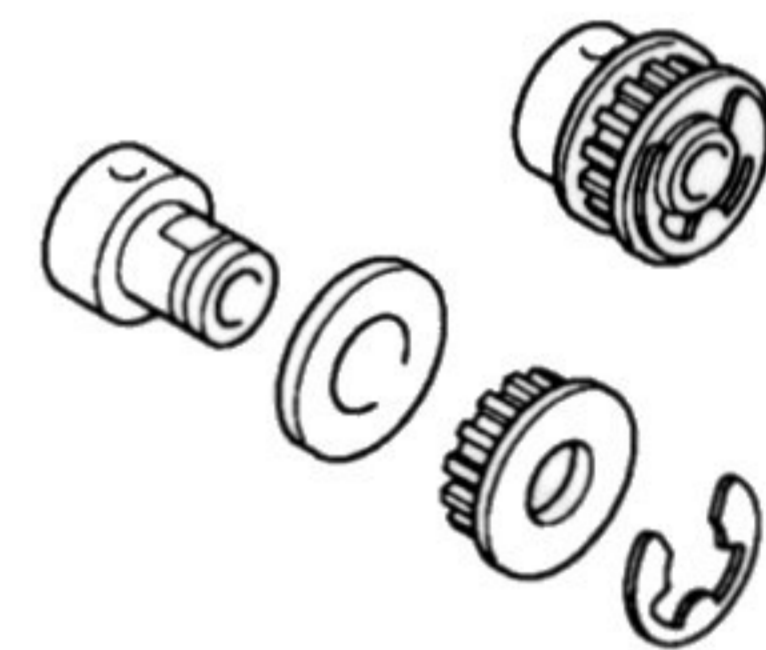

Press the 19T side pulley on the alu. pulley adapter, again using some cyano glue to get a firm fixing. Secure the pulley with the 7mm C-clips.

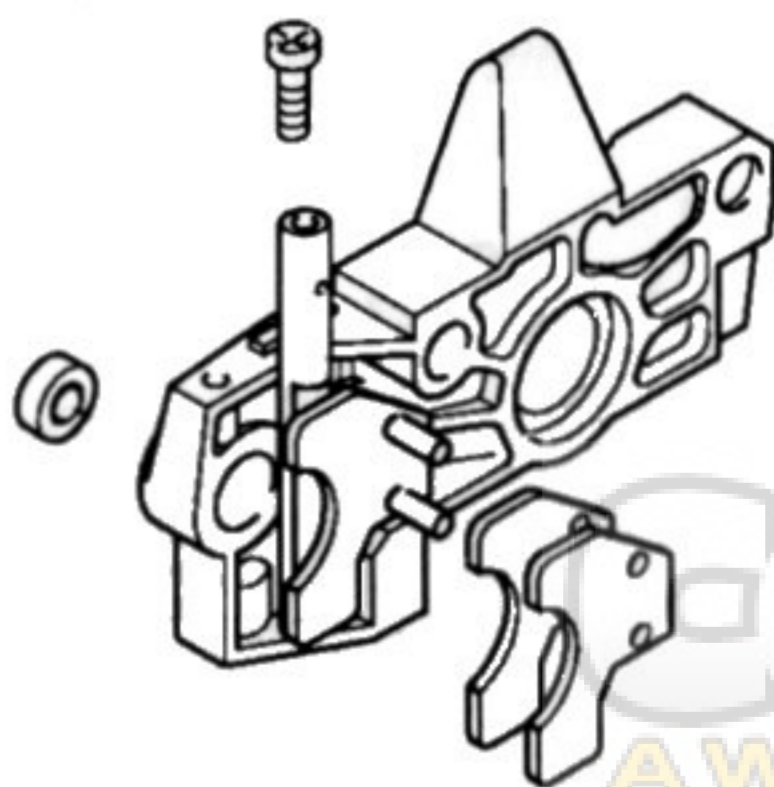

Press the 6x13mm ballbearing in the left and right bearing blocks. Place the alu. brake-cam in the 6mm hole of the right bearing block, apply the 3 brake-pads and the brake/pully adapter with the 2 brake-disks in place.

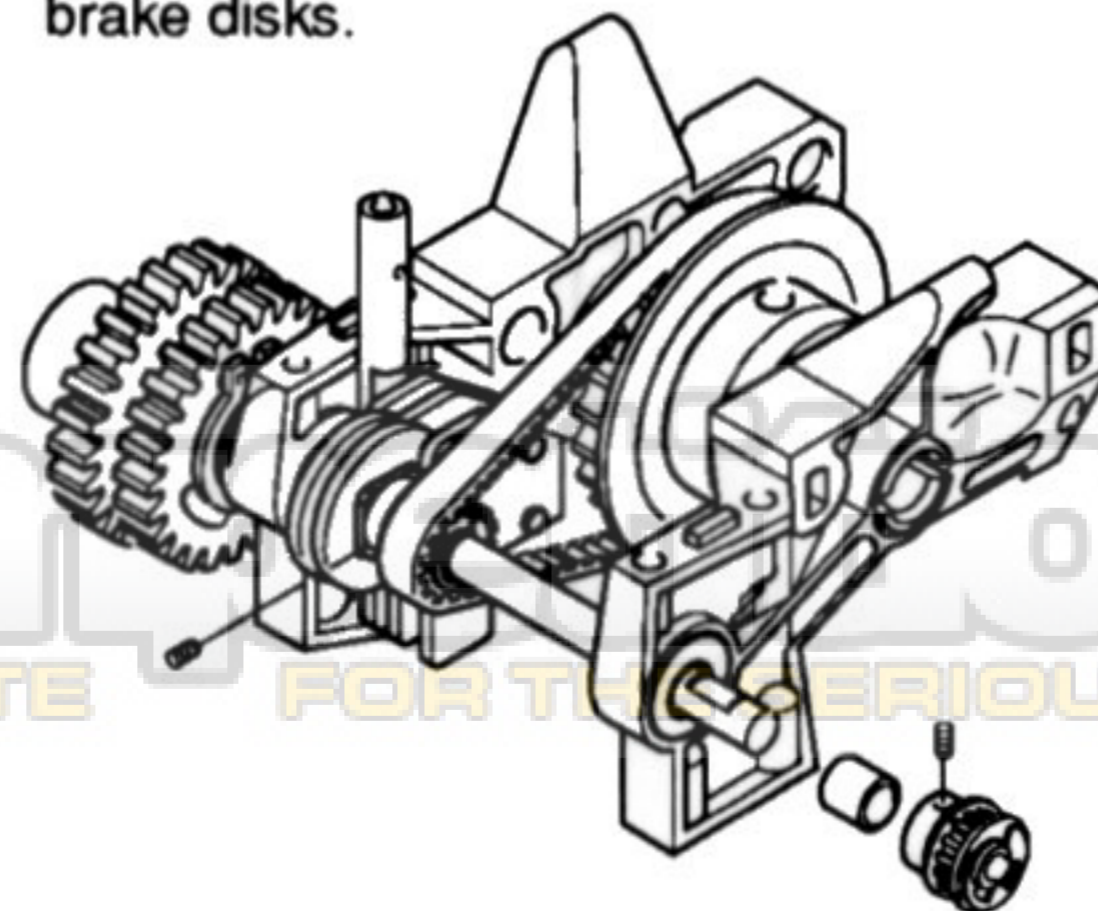

Insert the shaft of the 2-speed and fix the brake/pully adapter (setscrew M4x4) and the 19T side pulley (setscrew M4x6) with the small. alu. spacer. Use some Lock-Tite.

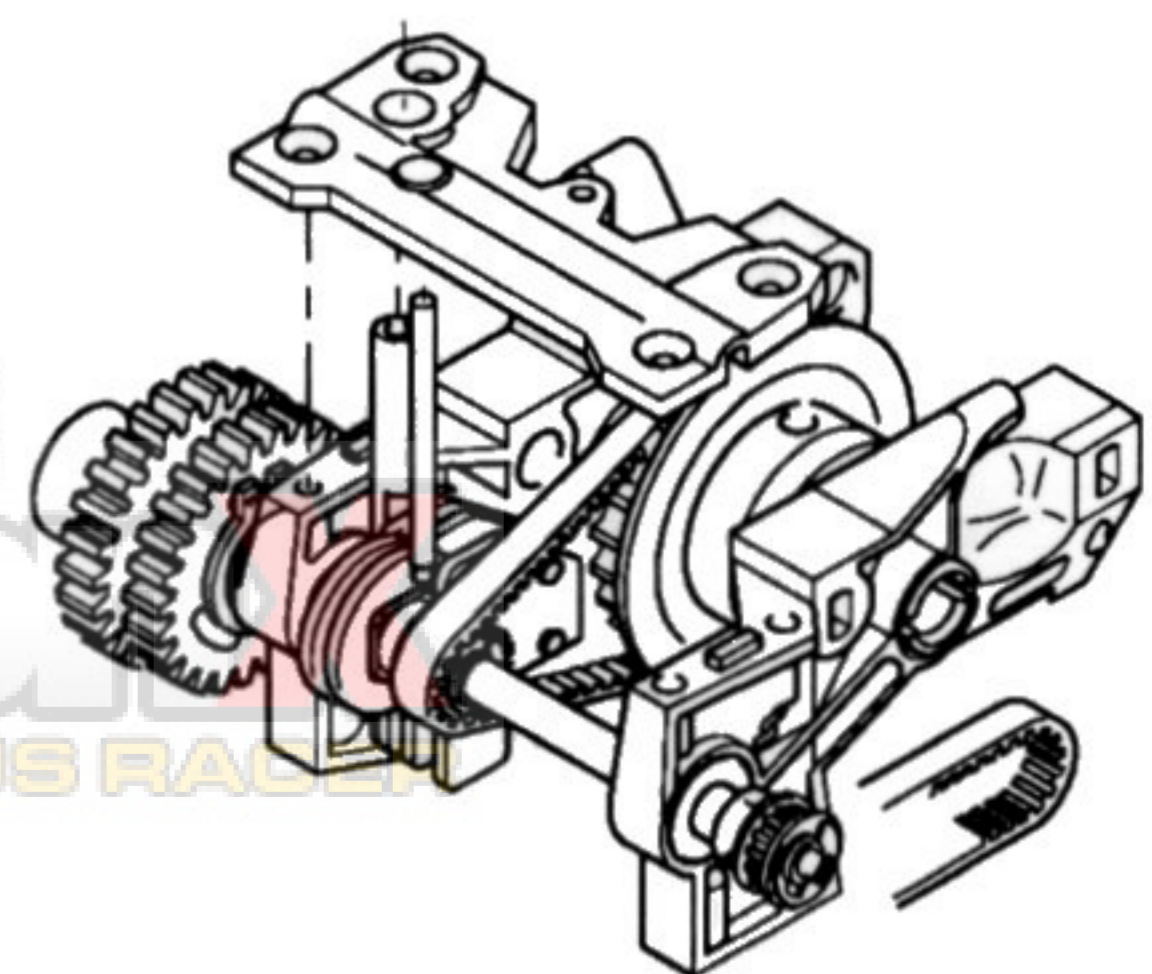

Press the steel brake-pad support pin in the 3mm hole of the chassis. The pin is supported at the top by the brake-bracket, lateron applied after the rear anti-roll bar is finished.

ASSEMBLING THE MIDDLE SHAFT

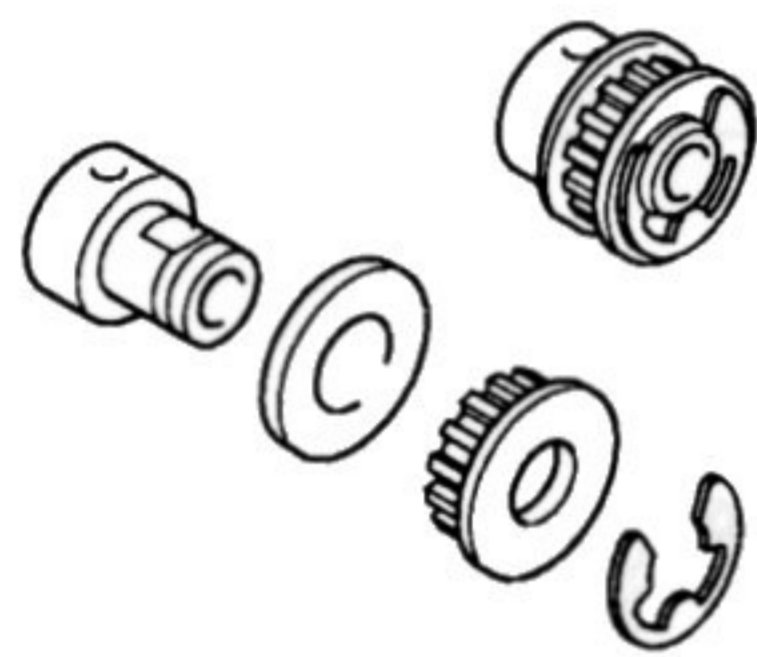
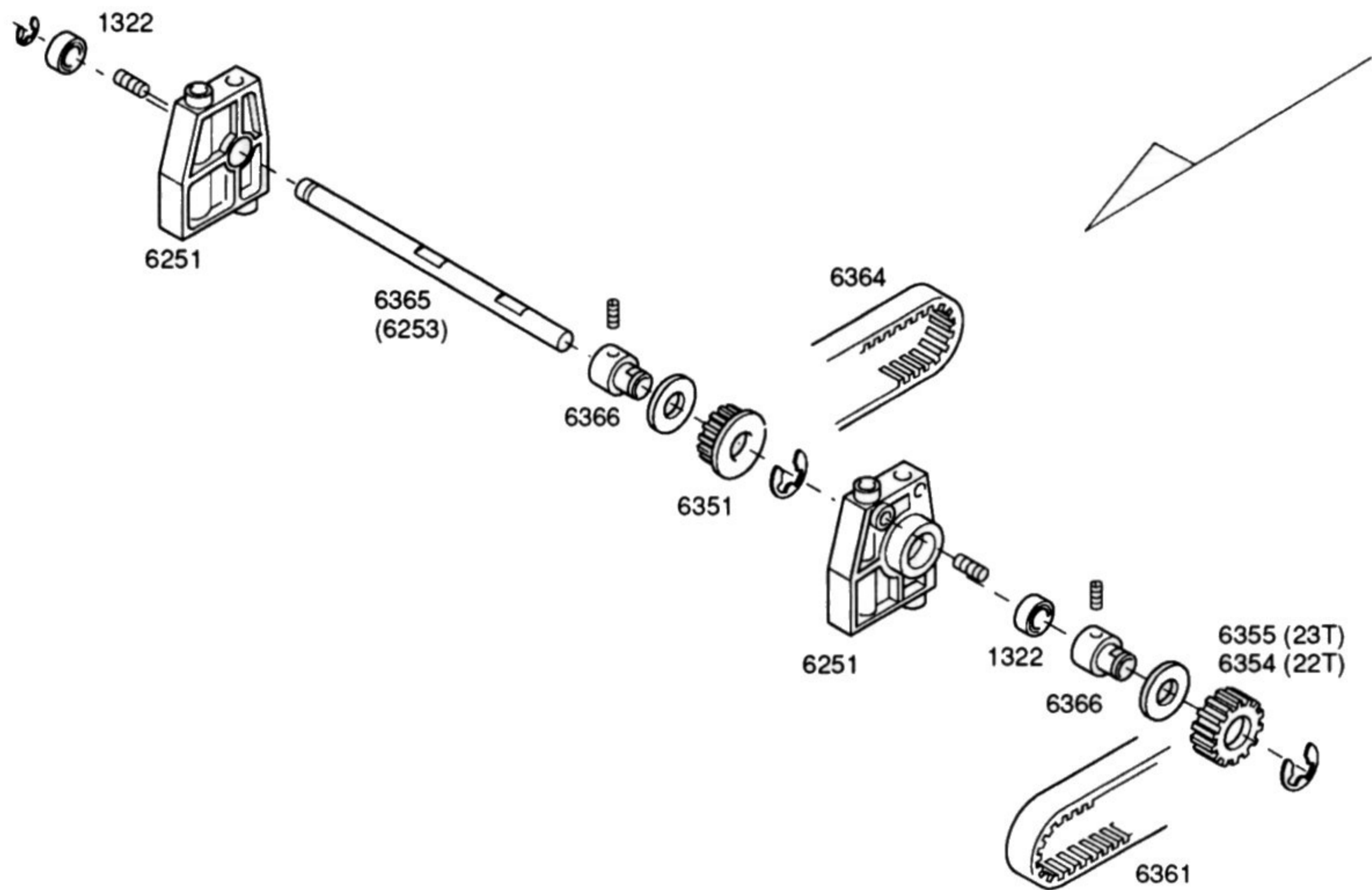

Press the 16T pulley on the alu. pulley adapter. Because of the small diameter of the pulley the use of a cyano-glue or other strong glue is necessary to get a very firm and reliable joint between the pulley and the pulley-adapter. Secure the pulley with the 7mm C-clips.

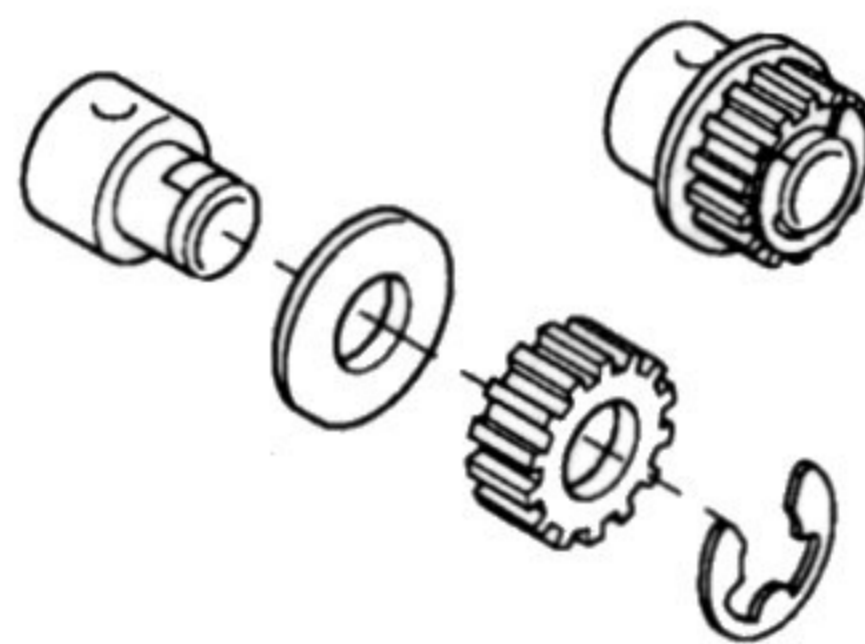

Mount the 23T pulley on the pulley adapter and secure it with the 7mm C-clips.

An alternative front-rear drive ratio can be obtained by using the 22T (#6354) pulley instead of the 23T pulley. This will put more overdrive to the front wheels. See the drive-ratio charts for more information.

Press the 6mm ballbearings in the bearing blocks. The blocks are mounted to the chassis with c.s.h. screws 3.5x13. Insert the M4x6 setscrews in the side of the blocks, with these screws the roll-overbar is fixed.

Apply the C-clips on the end of the shaft and insert the middle shaft, with the 16T pulley and the long timing belt in place. Align the timing belt with the front pulley, use setscrew M4x6 to fix it to the shaft. Apply the 23T pulley and fix it with setscrew M4x6. Use Lock-Tite on the setscrews. Allow a little sideplay on the shaft.

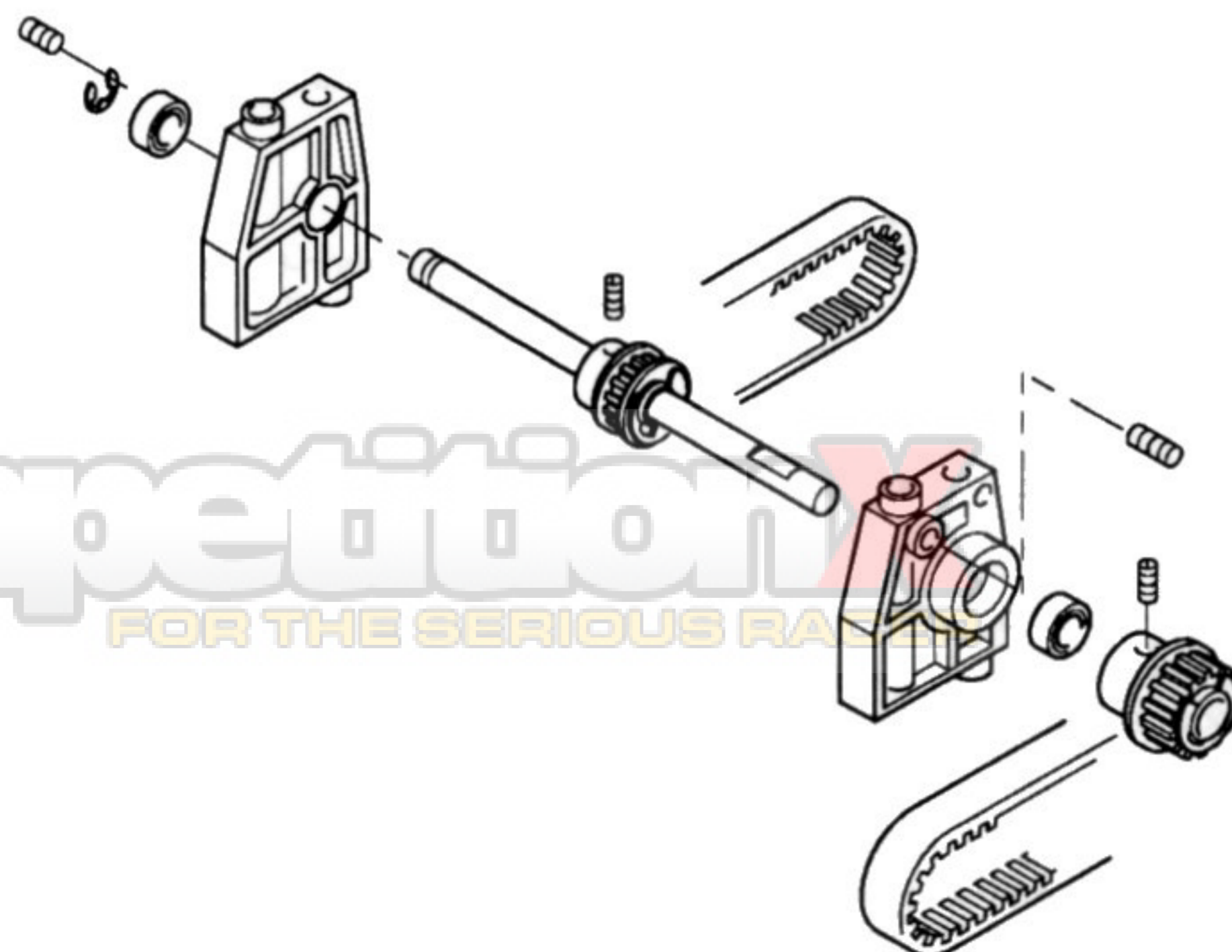

ASSEMBLING THE ANTI-ROLL BARS

FRONT

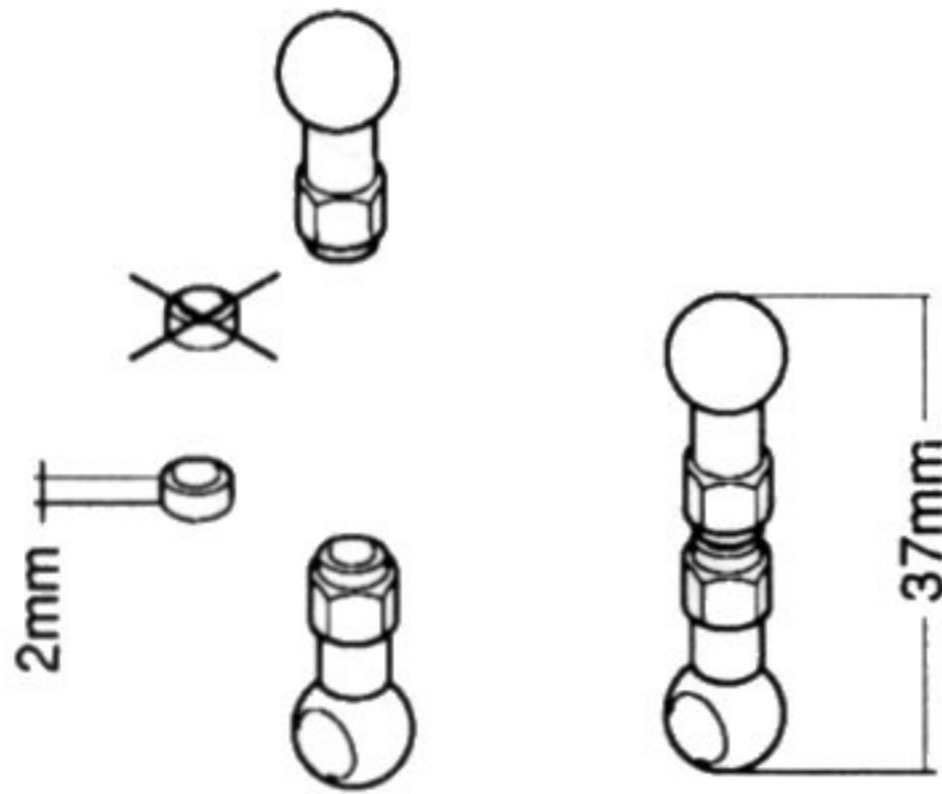

Cut the nylon balljoints 2mm. The balljoints are put together using the long M3x20 setscrew. Adjust the unit to a total length of 37mm.

Solder the brass 5mm balls (with 2.5mm hole) on both ends of the anti-roll bar.

The threaded balls are mounted to the lower front wishbones using the M2x6 screws and the 2.5mm washers.

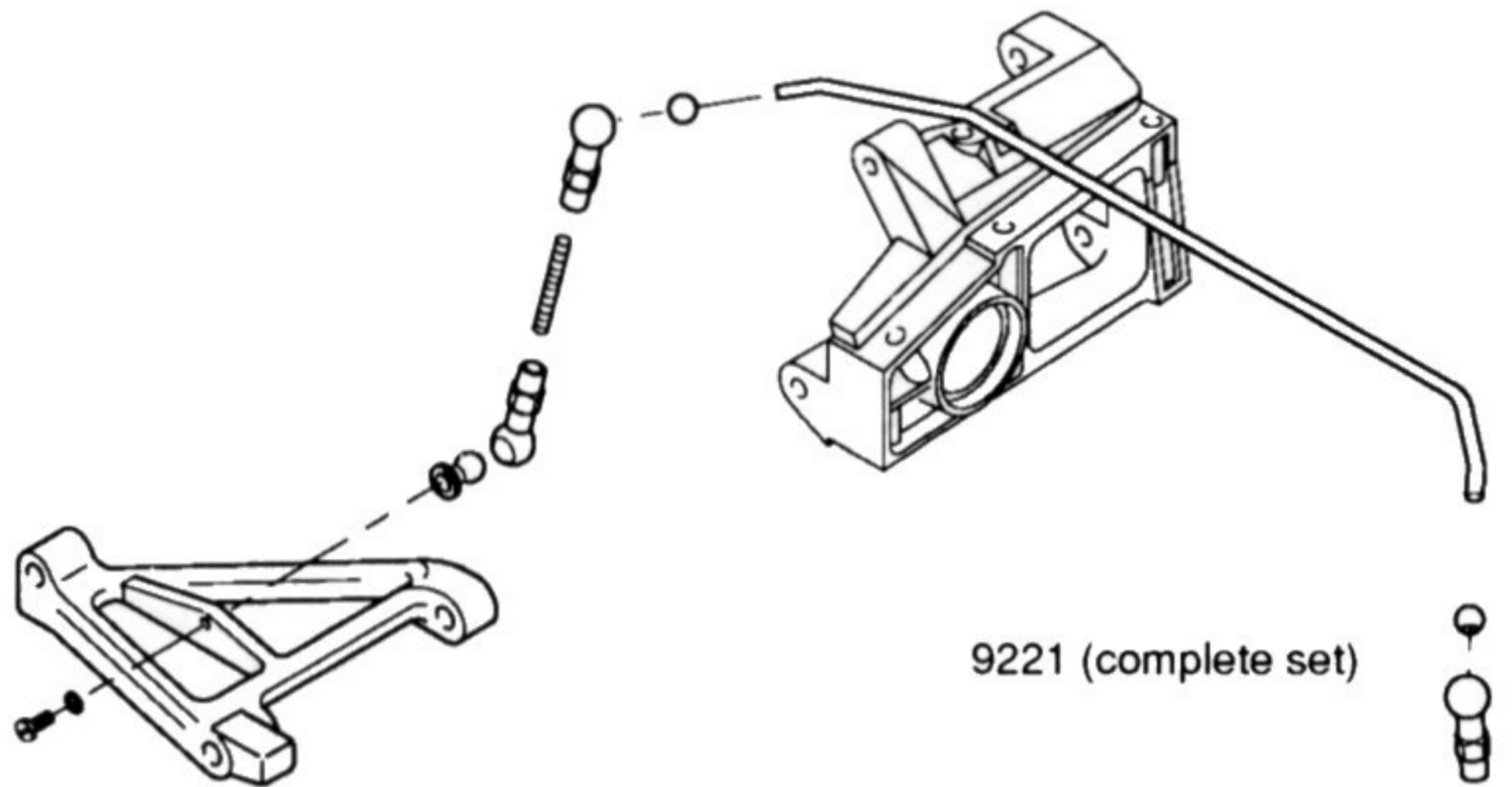

9221 (complete set)

The threaded balls are mounted to the lower front wishbones using the M2x6 screws and the 2.5mm washers.

The finished front anti-roll bar is mounted to the front brackets using r.h. screws 3.5x9.5. Check that the bar moves freely in the bracket.

Stiffer and softer front anti-roll bars will come available soon. They can also be modified by grinding a flat on the anti-roll bar.

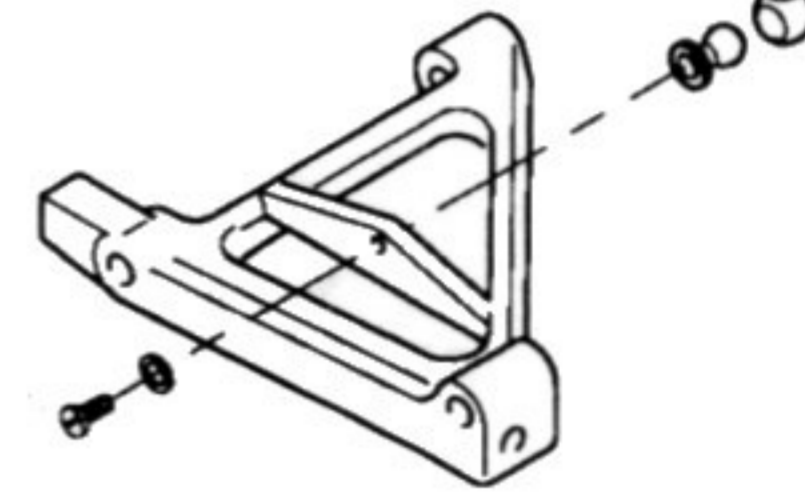

REAR

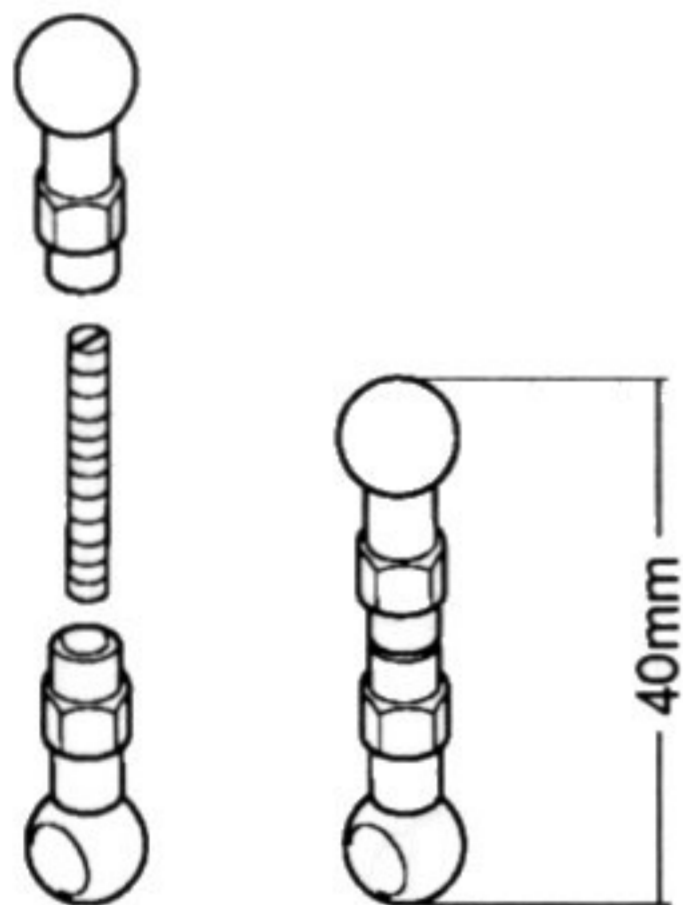

The balljoints for the rear anti-roll bars do not have to be modified. Assemble the 2 balljoints using the M3x20 setscrews. Adjust to a total length of 40mm.

Solder the brass balls with the 3mm holes on both ends of the rear anti-roll bar.

Mount the threaded 5mm balls to the lower suspension arms using r.h. screws M2x6 and the 2.5mm washer.

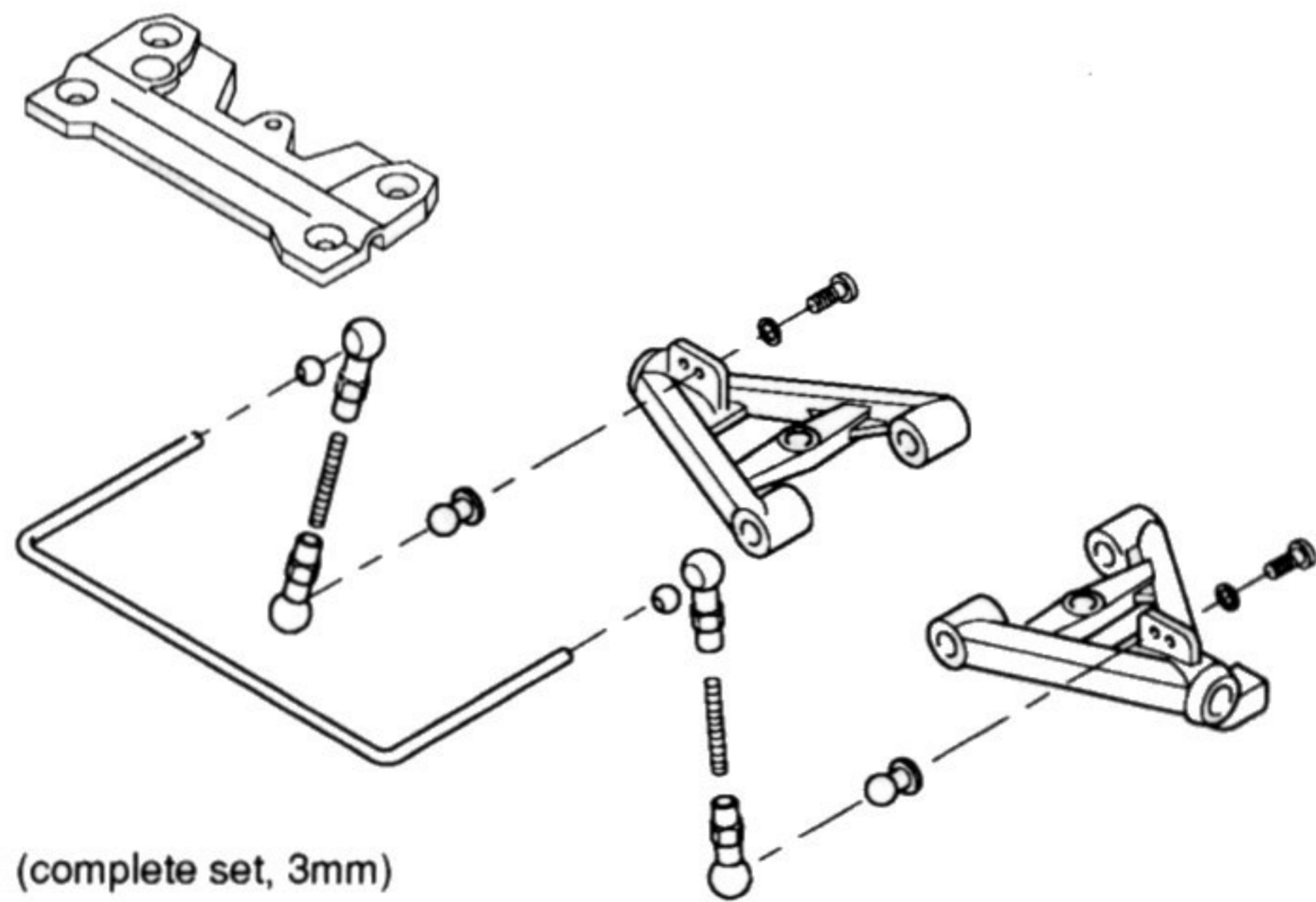

9321 (complete set, 3mm)

Softer rear anti-roll bars can be made by grinding a flat on of approx. 40mm wide on the anti-roll bar. The thickness of the anti-roll bar determines the stiffness.

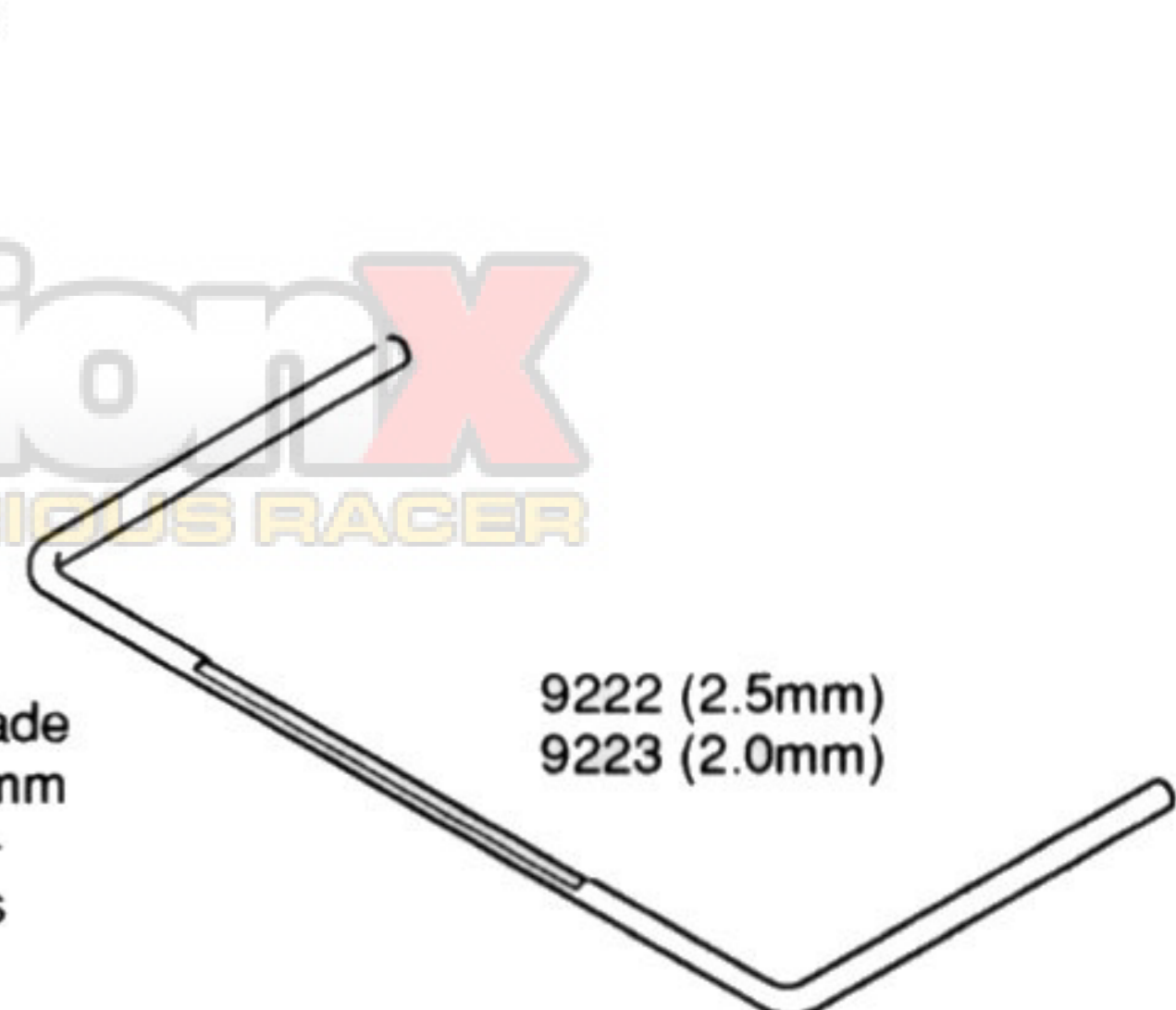

9222 (2.5mm)
9223 (2.0mm)

ASSEMBLING THE SHOCKABSORBERS

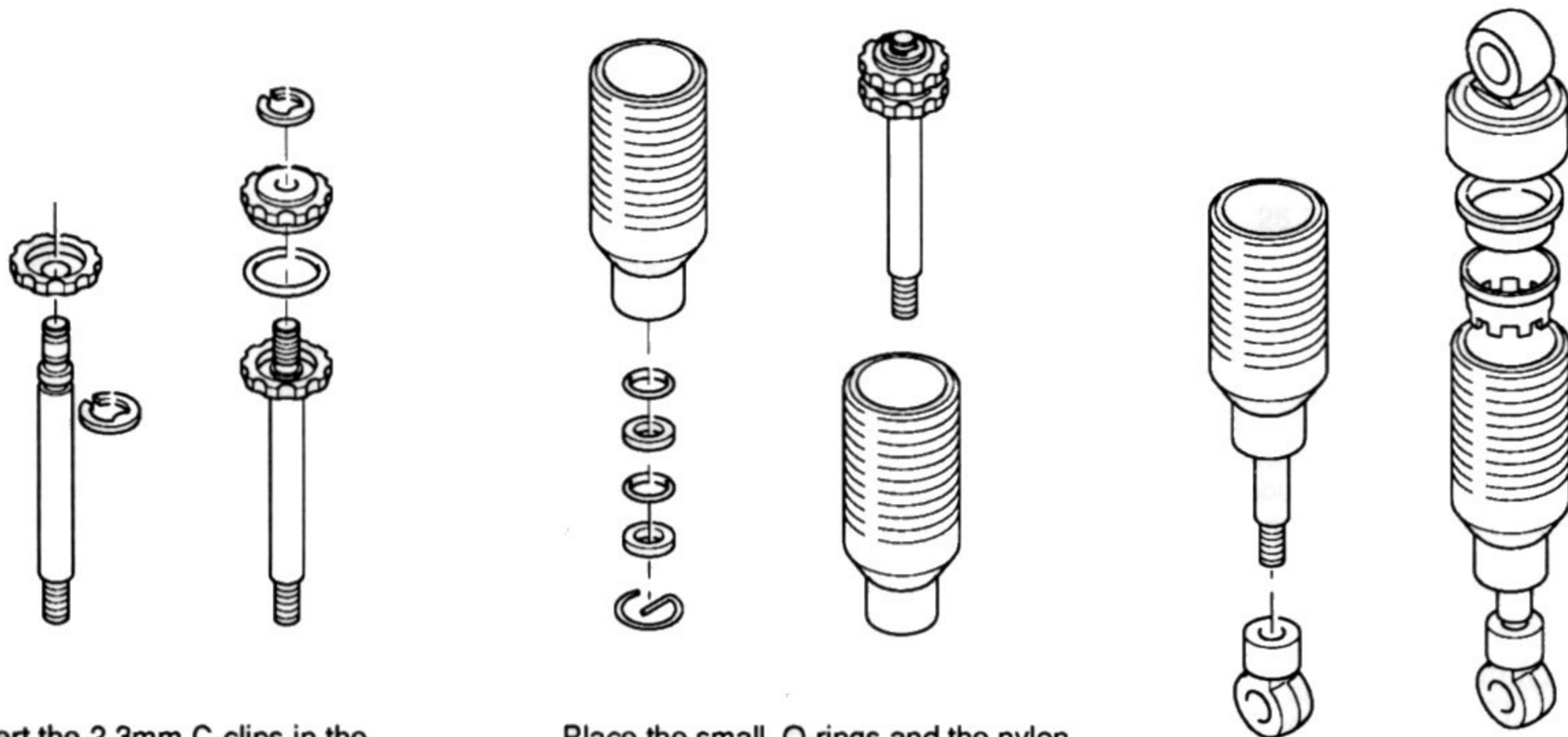
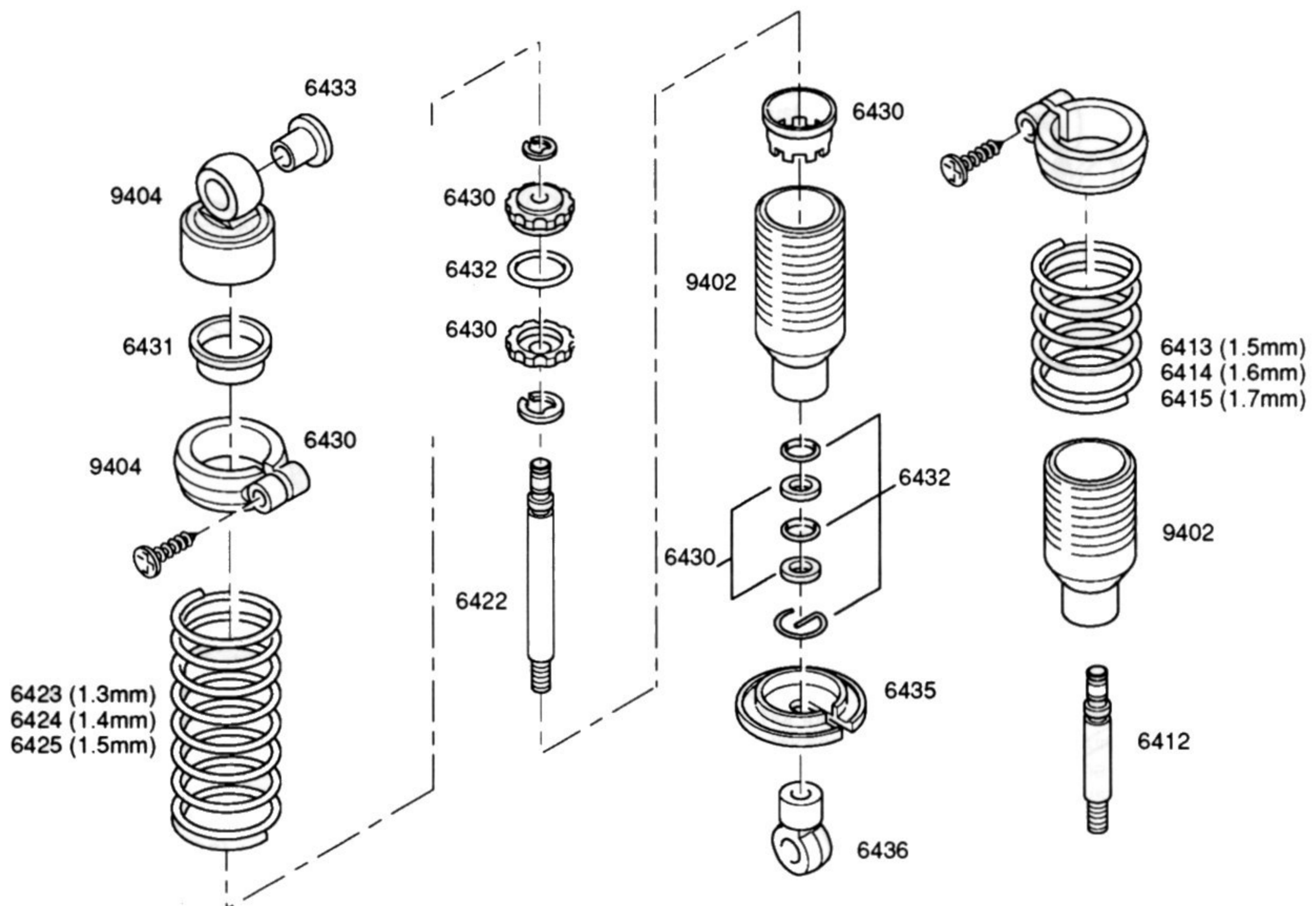

Insert the 2.3mm C-clips in the second groove of the piston rod and slide the piston with the bigger hole on the piston rod. Turn the second piston (smaller hole) on the M3 part of the rod, apply the 1.9mm C-clips and turn this piston back against the C-clips.

Apply the 6mm O-ring between the 2 pistons. By turning the top piston towards the lower piston, the O-ring will be squeezed to the outside and will so change the flow resistance of the pistons, thus changing the damping rate.

Place the small O-rings and the nylon guide bushings in the lower end of the cylinder. The retainer G-clips is inserted to keep the O-ring pack in place. Make sure that the G-clips is seated well. Apply some shock oil on the rod and gently push the piston rod through the O-ring pack. Screw the nylon rod-end to the rod, holding the rod on the thread with side cutters. Be careful not to damage the grinded part, this will cause leakage. Fill the shock with the special silicone based shockoil. Move the piston slowly up and down to allow the air to escape.

After all the air has escaped, the nylon cam bushing is pressed into the cylinder. Place the rubber membrane in the alu. pivot point and close the shock absorber with the piston half way.

Check the well functioning of the shock absorber and adjust the damping rate. Push the rod all the way in to lock the upper piston in the cam bushing. The upper piston can only reach the cam with the spring not installed. Make sure the damping rate left and right is equal.

ASSEMBLING THE CENTAX CLUTCH

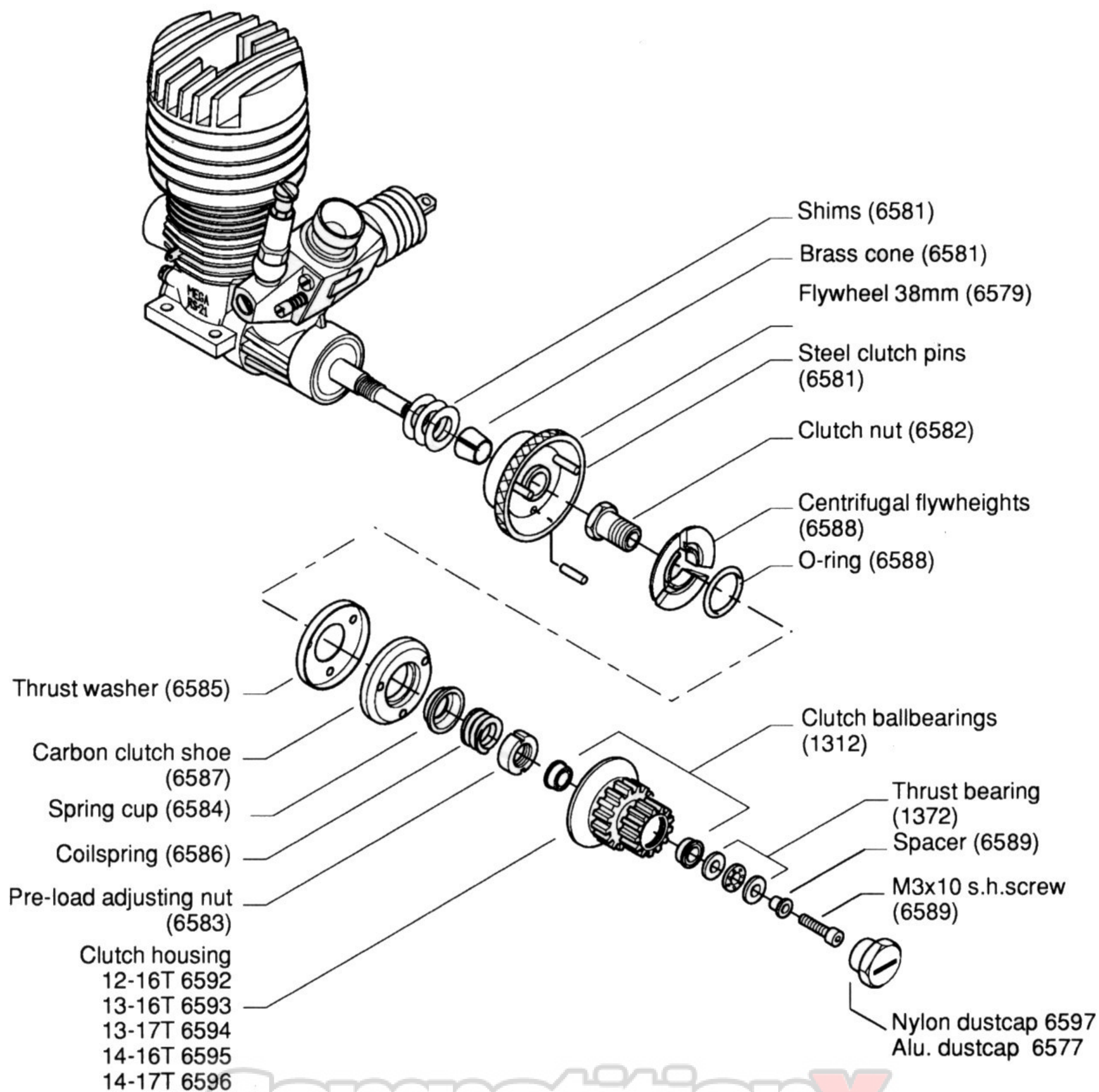

CompetitionX
 A WEB SITE FOR THE SERIOUS RACER

ASSEMBLING THE CENTAX CLUTCH

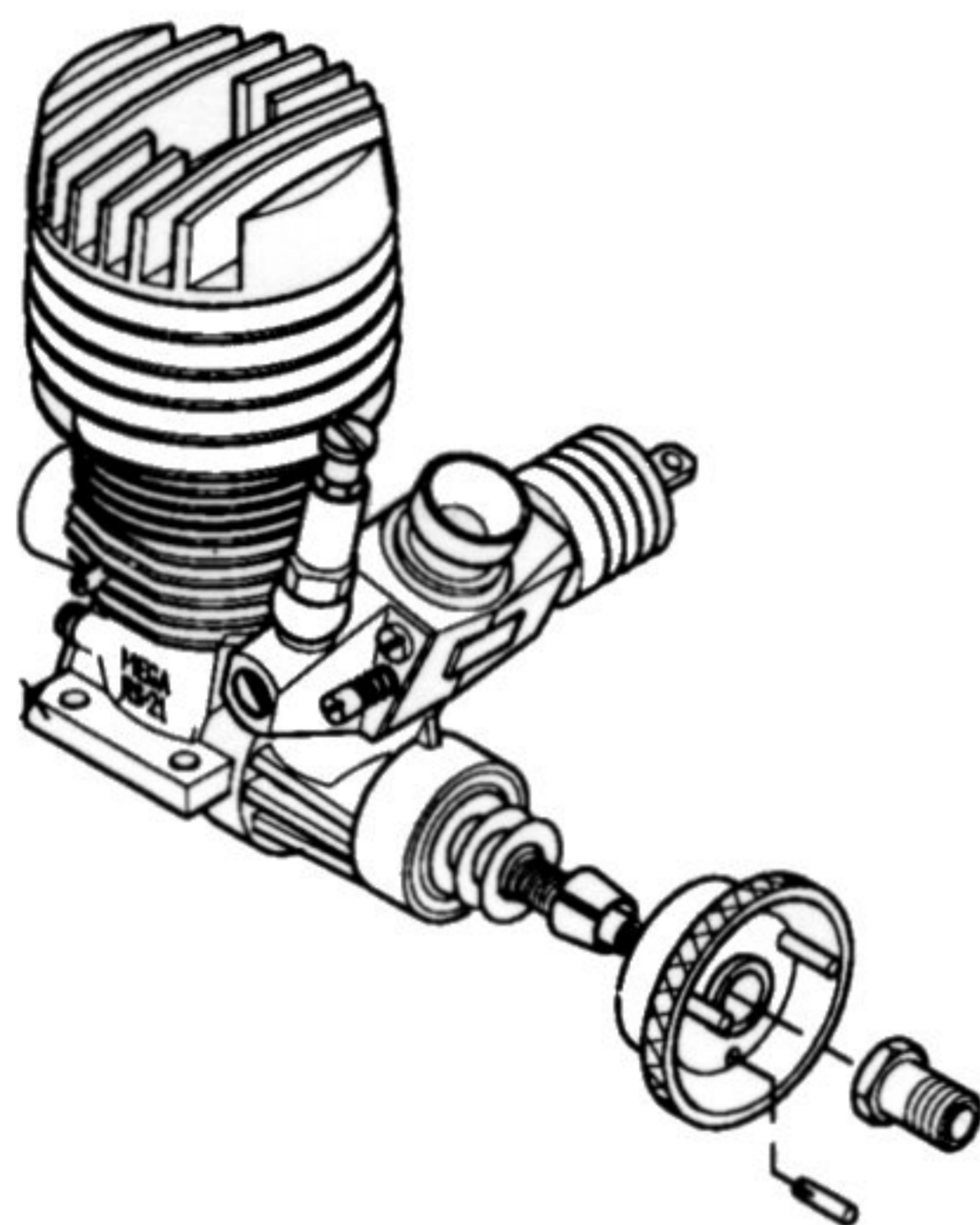

The CENTAX clutch is a whole new concept and will require some time to fully understand the details of this clutch. Once set up right you will be amazed about the extra performance of your engine, especially at bottom-end. Follow the assembling instructions and setting-up procedures to obtain the best results from your CENTAX clutch.

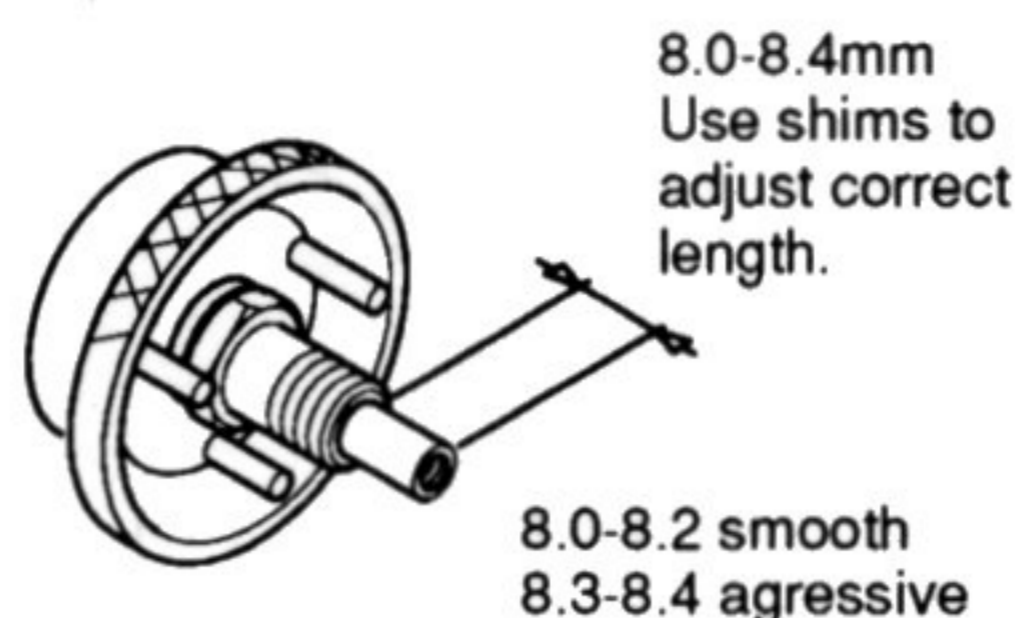

Insert the 2.5mm pins from the back-side of the flywheel, making sure that the pins do not protrude. To obtain the right axial play on both the clutch shoe and the clutch bearing, careful shimming of the flywheel is required. Apply the flywheel to the crankshaft and tighten the clutchnut. Take a measurement from the end of the crankshaft till the end of the clutch-nut. The required size is 8.2mm. The difference between your reading and the 8.2mm should be added behind the flywheel. For this shims of 0.1 0.3 and 0.5mm thickness are included with the clutch. After having applied the shims make sure you tighten the clutchnut thoroughly and check this size again.

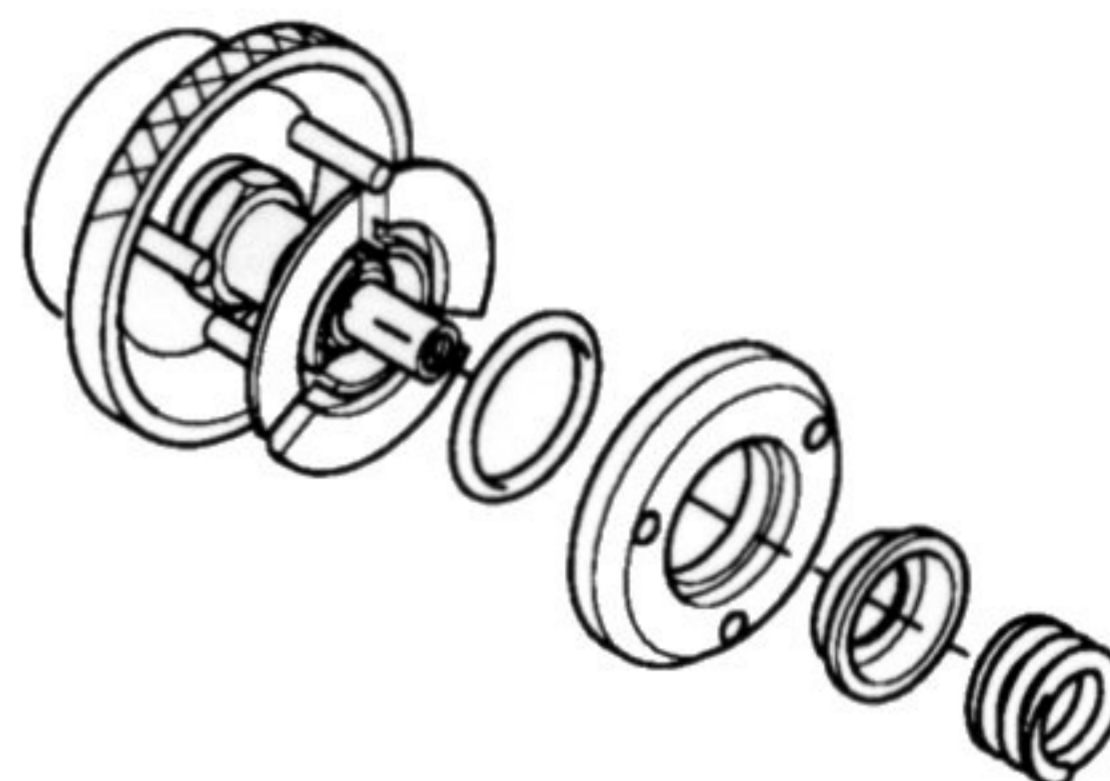

Apply the 3 flyweights and place them in the flywheel, the O-ring is put in the groove. Apply the thrust plate, followed by the carbon filled clutch shoe (must slide freely over the pins), and the spring cup. Place the spring over the clutchnut and apply the adjusting nut. Check that the spring is not tight in the spring cup. With this nut the spring-tension can be adjusted. As a start, set the adjusting nut at 9.2mm measured from the end of the crankshaft. The spring-tension can be increased by turning the adjusting nut further on to the clutch nut, causing the clutch to engage later. This adjustment can be made by inserting a 1.5mm pin (or .050 allen-key) through the small hole in clutch housing.

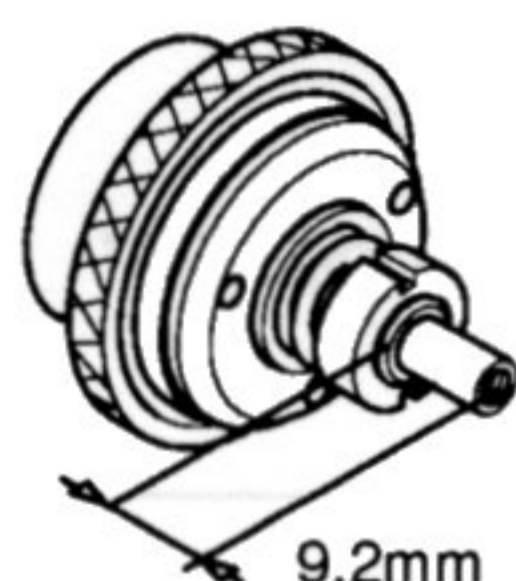

next the carbon filled clutch shoe, and the spring cup. Place the spring over the clutchnut and apply the adjusting nut. With this nut the spring-tension can be adjusted. As a start, set the adjusting nut at 9.2mm measured from the end of the crankshaft. The spring-tension can be increased by turning the adjusting nut further on to the clutch nut, causing the clutch to engage later. This adjustment can be made by inserting a 1.5mm pin (or .050 allen-key) through the small hole in the clutch housing. Find the slot in the adjusting nut and then turn it clockwise whilst holding the flywheel. Remove any grease or oil from the clutch-housing. Apply the flanged ballbearings to the clutch housing. Now place the small 4mm thrustbearing over the spacer-bushing and secure the clutch housing with the M3x12 sockethead screw. Check that the clutch housing spins nice and free and that the ballbearings have a little sideplay.

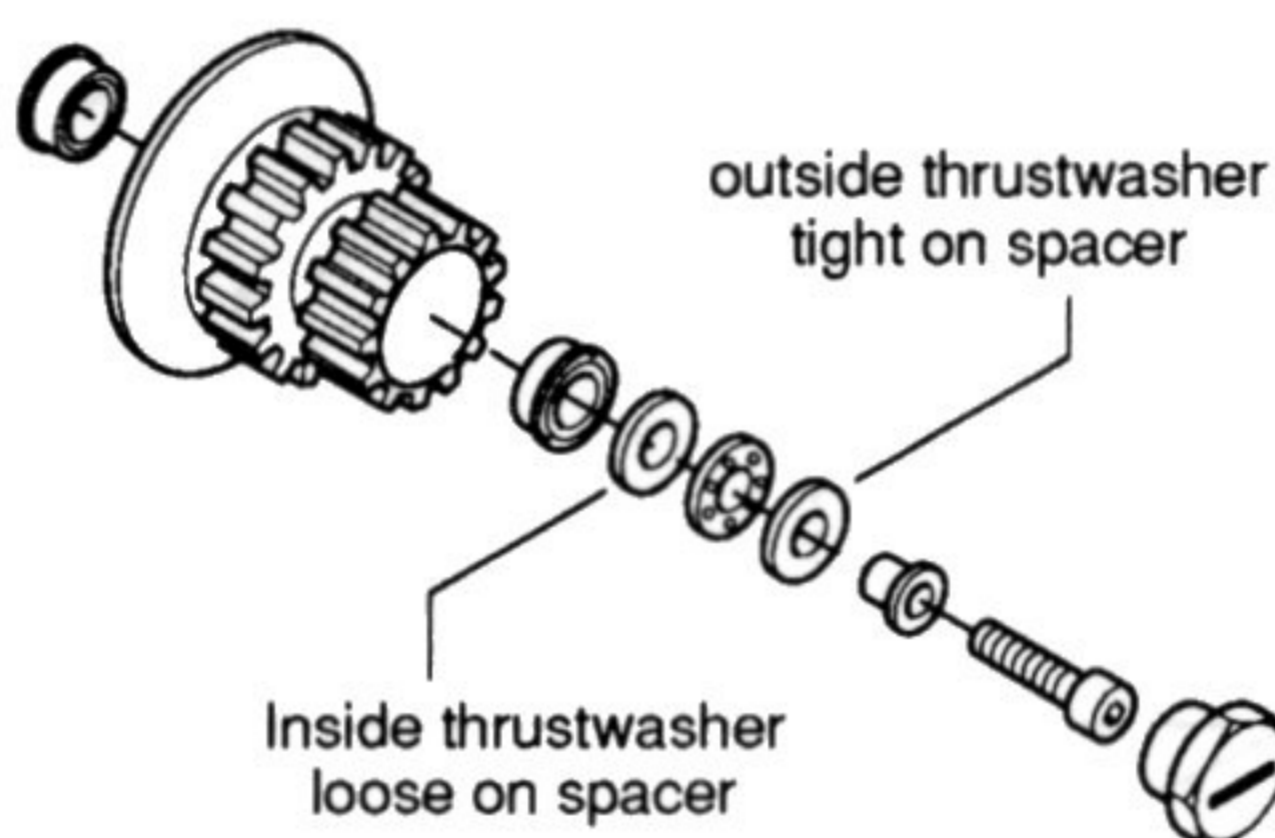

SETTING-UP THE CENTAX CLUTCH
The clutch slip can be adjusted with the adjusting nut. The correct setting can only be made in the car and may depend on your engine and gear-ratio. Too late engagement will increase clutch-wear and will cause less bottom punch. **NEVER ALLOW THE CLUTCH TO SLIP, STOP IMMEDIATELY AND RE-ADJUST THE CLUTCH.** When running-in a new engine, set the clutch on 9.0mm. Also in wet or very slippery conditions it is better to let the clutch come in earlier. **DO NOT TEST THE CLUTCH UNDER FULL POWER WHILE KEEPING THE WHEELS STILL. THIS WILL DAMAGE THE CLUTCH.** The distance between the clutch housing and the clutch shoe is also very important for the 'punch' you can get from your clutch. Fine adjustments can be made by shimming the flywheel backward or forward. Always check for enough end-play on the clutch ballbearings.

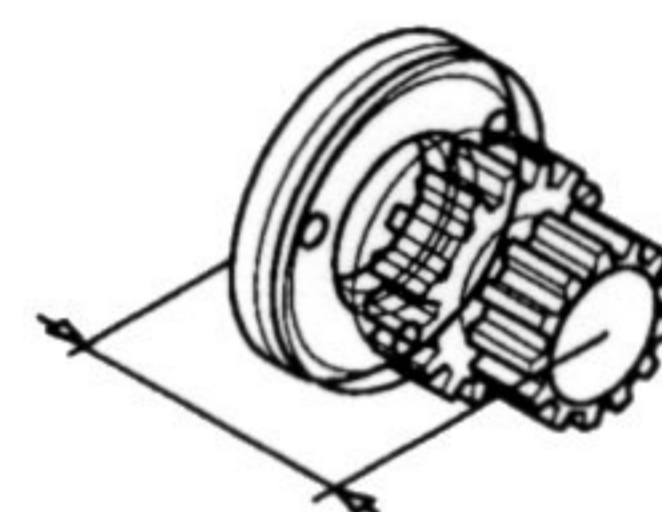

25.7-25.8mm new clutchshoe
25.4-25.5mm worn clutchshoe

MAINTENANCE 1. Check the wear on the clutch shoe every 2 hours. Measure the clutchshoe in the clutchhousing. The total measure should not be less than 25.4-25.5mm, replace if less. Also check that the wear pattern is even. If the clutchshoe looks doubtful, replace. 2. Check the flyweights every 2 hours. The flywheel surfaces should not be deformed or worn. If you decide to change the flyweights, also replace the O-ring at the same time. **DO NOT CUT OR MODIFY THE CLUTCHSHOE OR THESE FLYWEIGHTS. THIS WILL OBSTRUCT THE WELL FUNCTIONING OF THE CENTAX CLUTCH.** 3. Check the small thrust-bearing regularly and apply some teflon grease. If this bearing fails, the whole clutch will be damaged!

NOTE: The mentioned settings apply to SERPENT P-5 and SERPENT MEGA RS-21 engines. Other make of engine may require different settings.

ASSEMBLING THE REAR BODYMOUNT

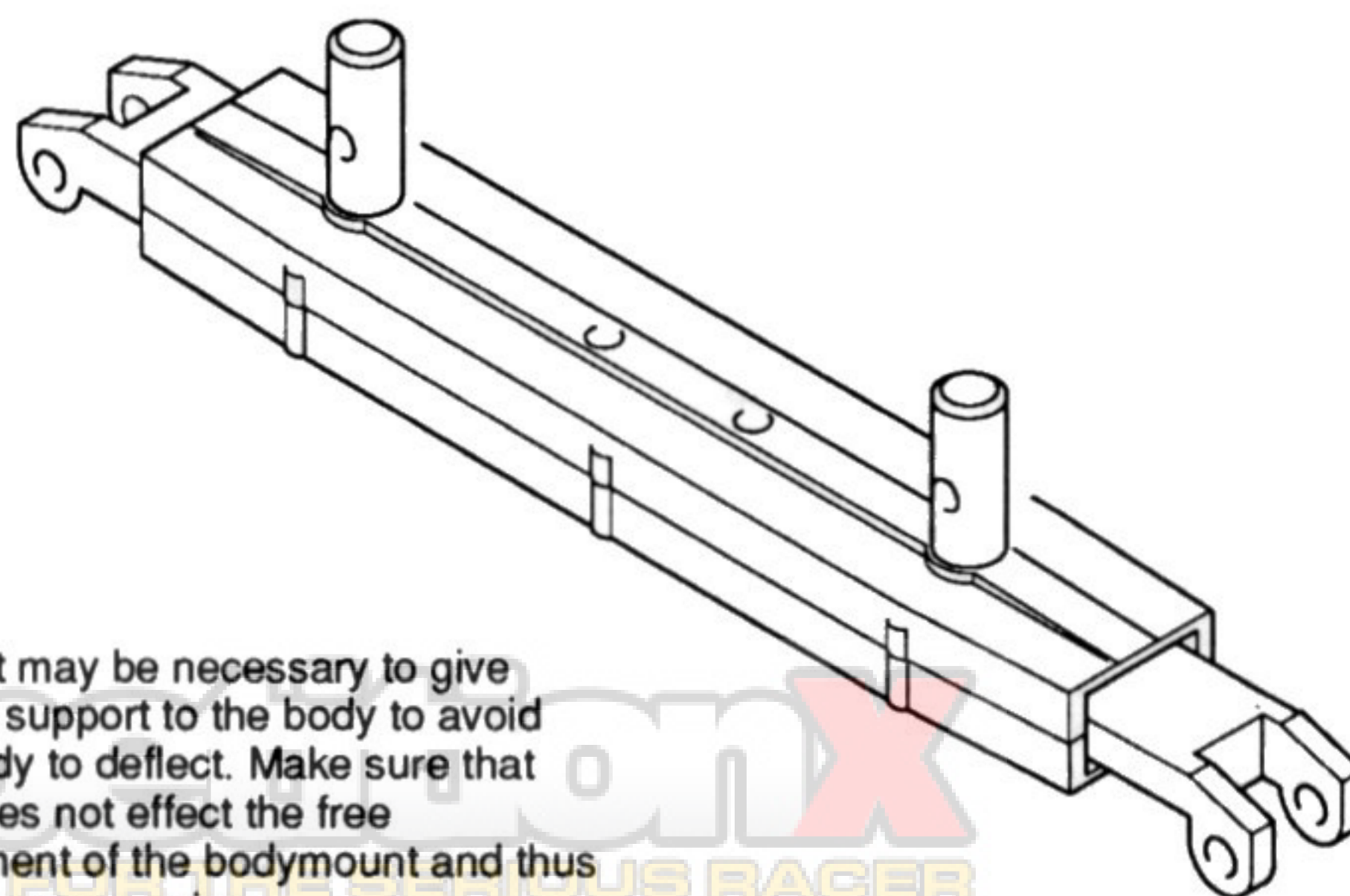
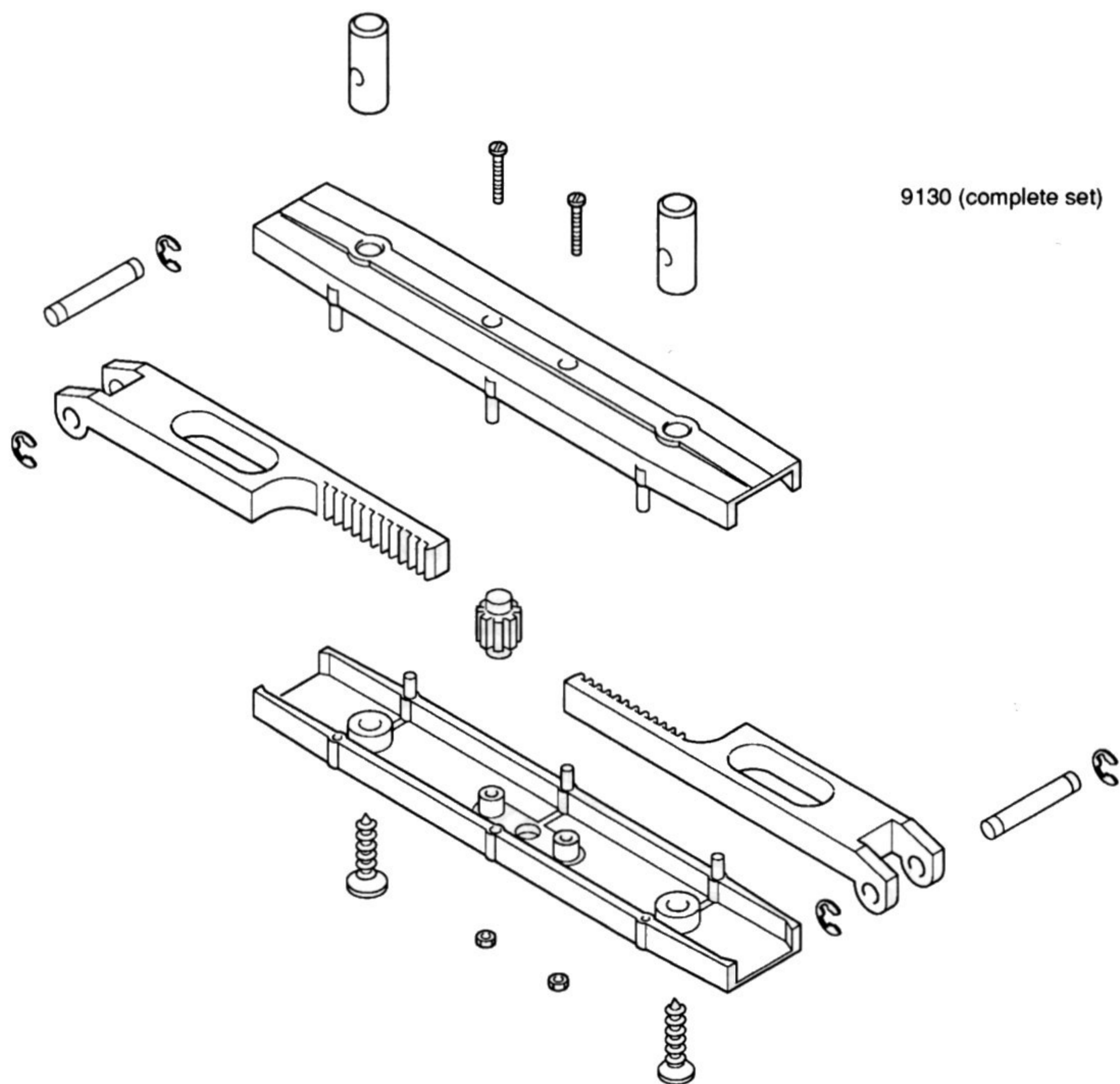

Place the small gear in the lower bracket and place both arms in such a way that the left and right arm protrude equally. Apply the upper bracket and fix both parts together with the M2x10 and the small nuts. The 2 bodyposts are mounted with r.h. screws 2.9x13. If the longer posts are used, the holes of 2.0mm must be drilled at the desired position. Avoid the screw.

Check that both arms move freely in and out. The rear bodymount is fixed to the upper holes of the up-rights using the steel pin and the 2 C-clips.

Note: it may be necessary to give further support to the body to avoid the body to deflect. Make sure that this does not effect the free movement of the bodymount and thus the rear suspension.

A special bracket is under development to cope with such situations. This bracket takes away the torsion on the rear bodymount.

INSTALLING THE RADIO EQUIPMENT

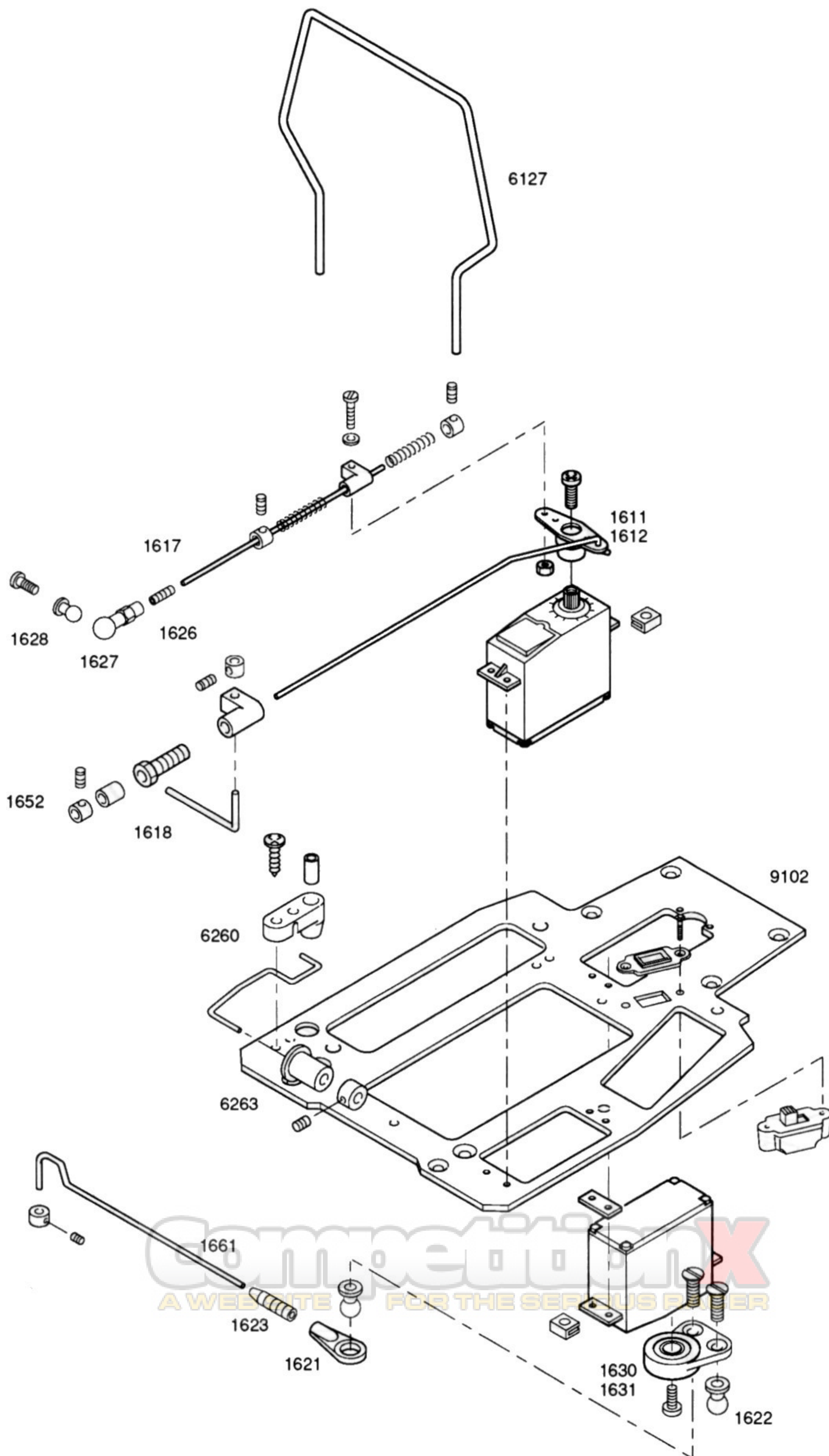

CHASSIS RADIOPLATE AND BUMPER

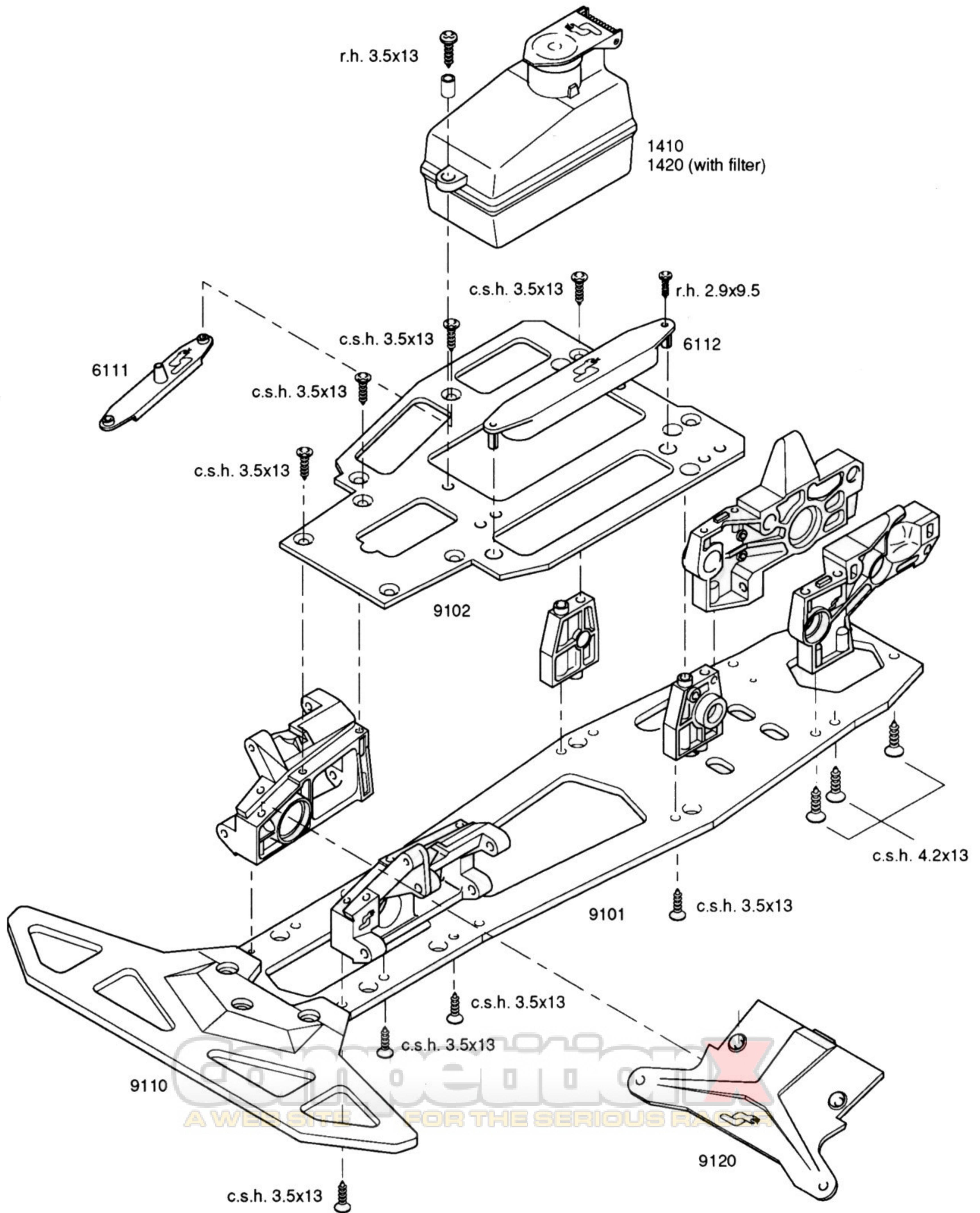

SETTING-UP THE SERPENT EXCEL

REAR VIEW

rear camber

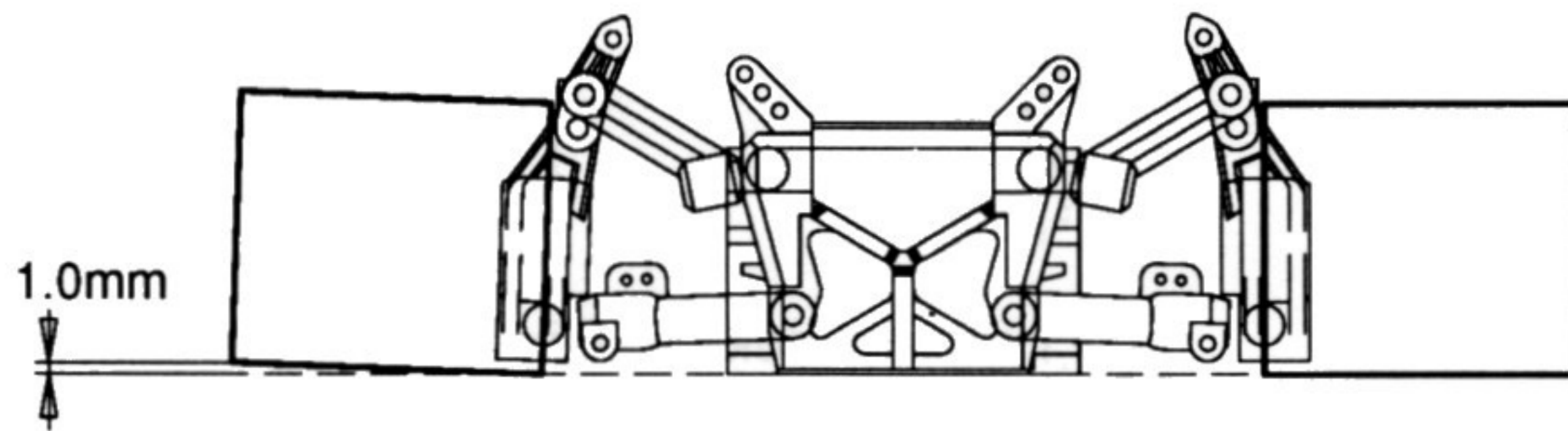

chassis flat on the ground, use rims without tire to adjust suspension

TOP VIEW

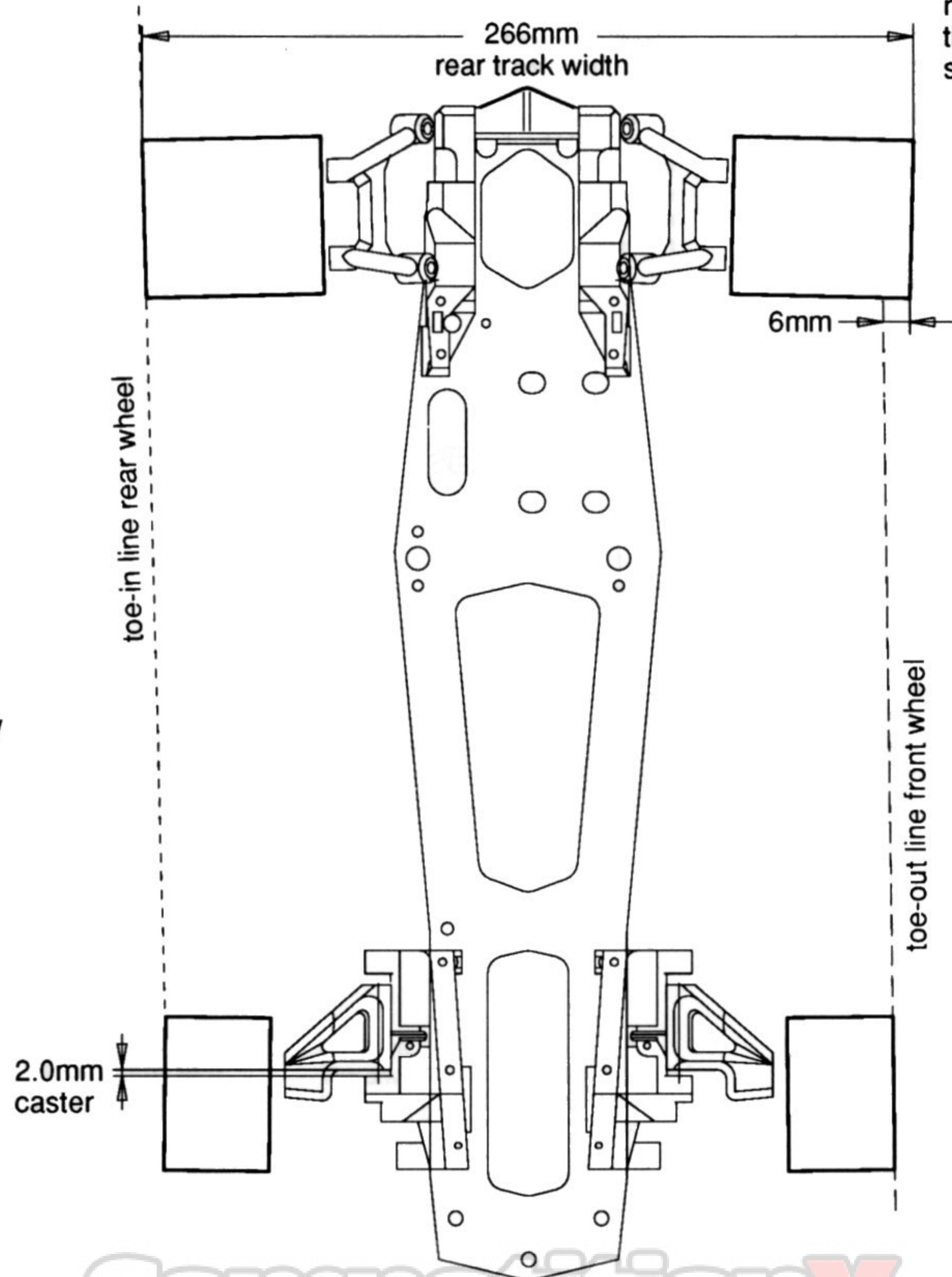

2.0mm
caster

6mm

toe-in line rear wheel

toe-out line front wheel

FRONT VIEW

front camber

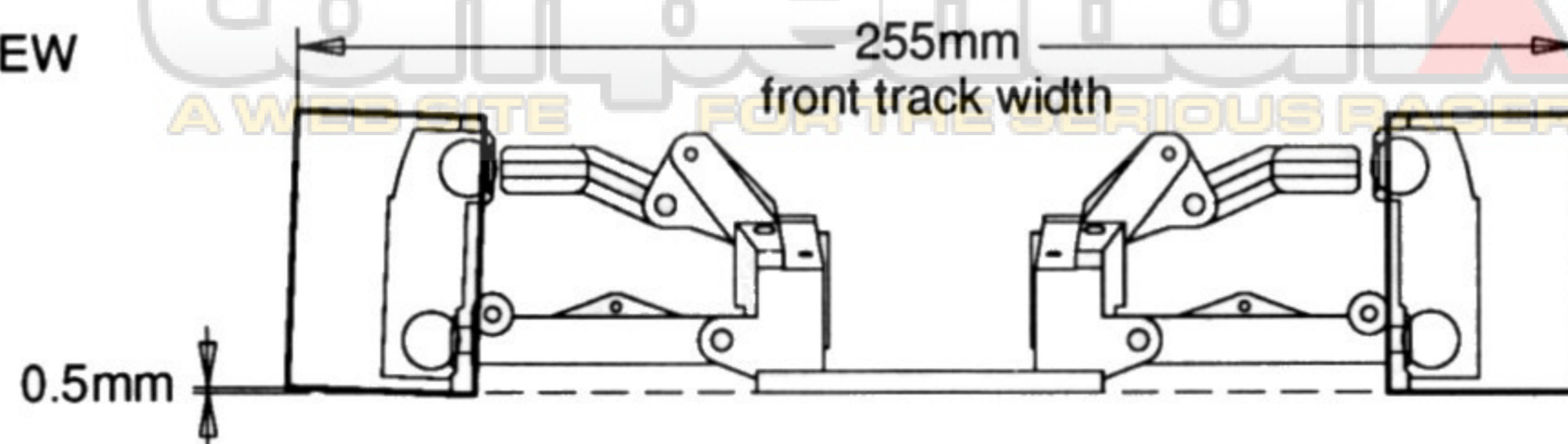

chassis flat on the ground, use rims without tire to adjust suspension

255mm
front track width

0.5mm

front camber

SETTING-UP THE SERPENT EXCEL

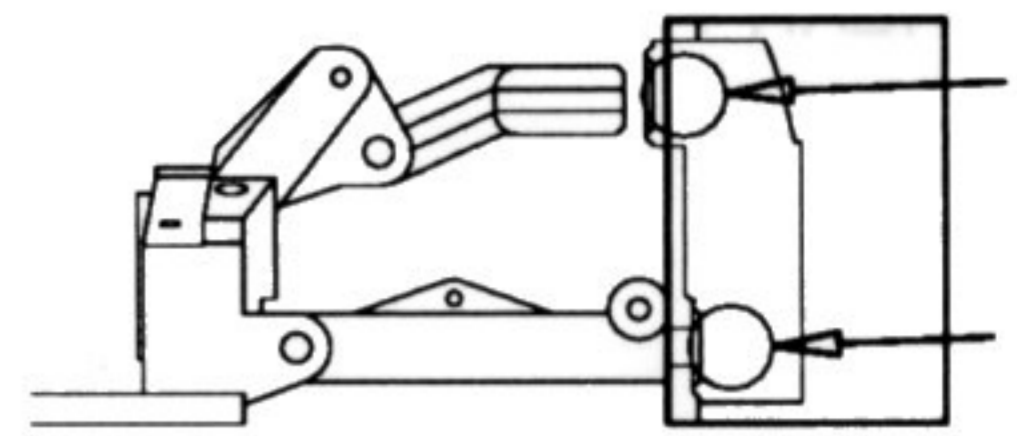
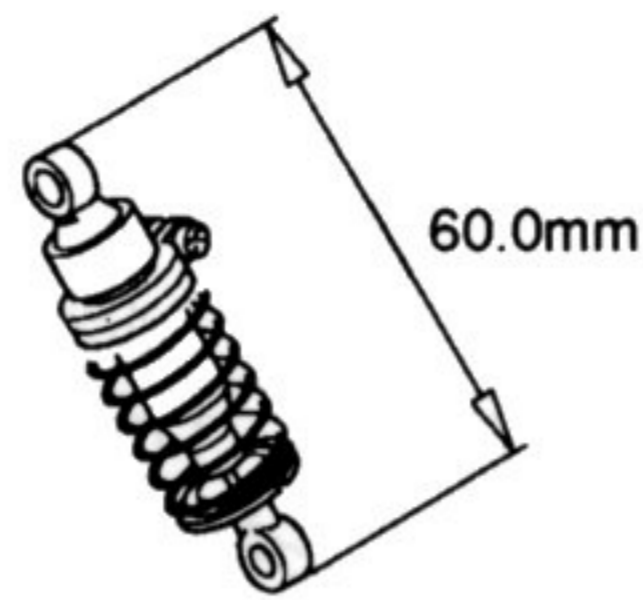

GENERAL

To set-up the suspension it is necessary to have always available 1 set of front and 1 set of rear rims WITHOUT tyres. All the settings are made with only the rims mounted on the car. Follow the setting-up procedure step by step to achieve the best results. Ofcourse this is a basic setting and minor changes may be required to suit your own personal driving style, tyre choice and track conditions.

STEP 1: FRONT SHOCKABSORBERS

Take off the front shock absorbers. Adjust the total length of the fully extended front shockabsorbers to 60mm. The length can be adjusted by turning the nylon rod end on the piston rod. Check that the alu. pivot point moves freely. Also both track rods should be disengaged. Check the free movement of the front suspension and steering blocks, re-adjust the alu. M12 nuts if necessary.

STEP 2: TRACK WIDTH FRONT

Set the width of the front end to 255mm, left and right equally adjusted. The adjustment is made by turning both the top and the bottom pivot balls. Keep the front rim flat on the surface.

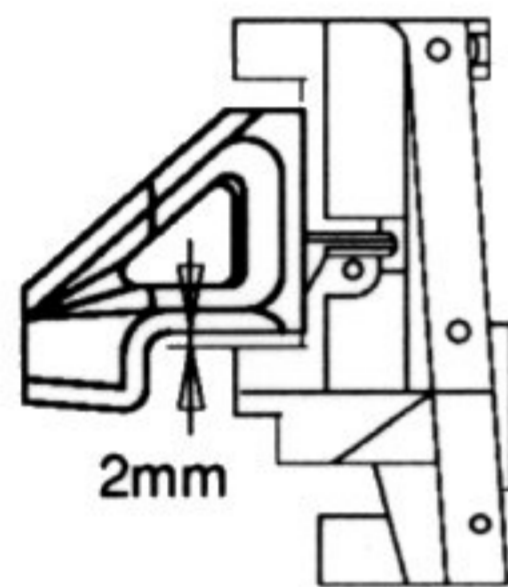

STEP 3: CASTER ANGLE FRONT

The caster angle is adjusted by sliding the upper front wishbone backwards or forward. Start with 2mm

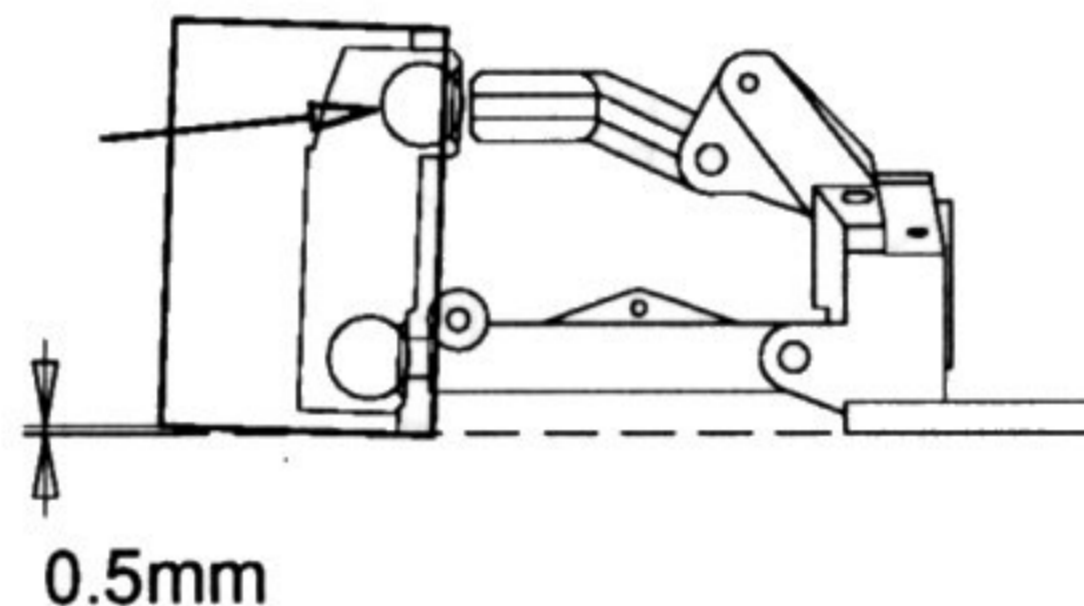

STEP 4: CAMBER ANGLE FRONT

With the chassis flat on the ground the camber angle can be adjusted. Adjust the upper pivot ball until the front rim has 0.5mm clearance on the outside.

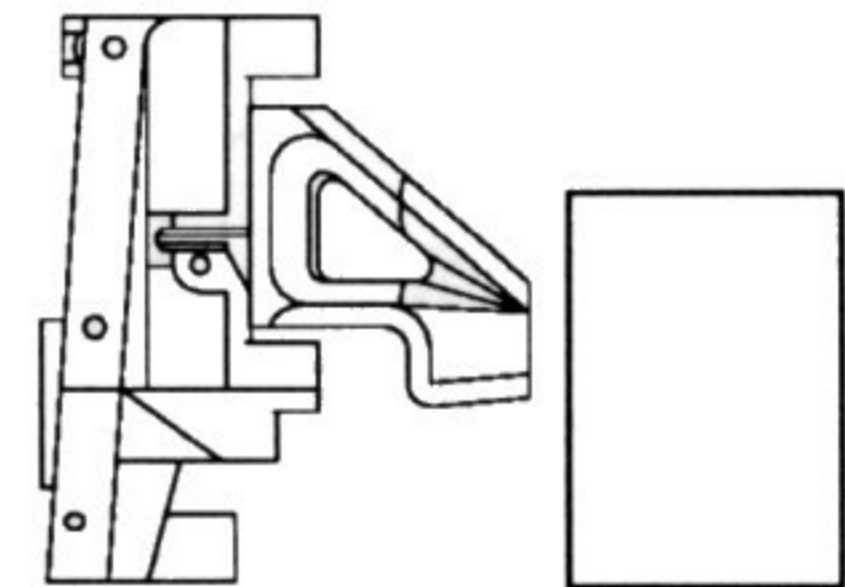

STEP 5: TOE-IN FRONT

The toe-in is first set in neutral (zero degree) position, meaning the front rims are absolutely parallel. The toe-out can be set after the rear suspension has been properly adjusted. Toe-in and toe-out is adjusted by changing the track rod length.

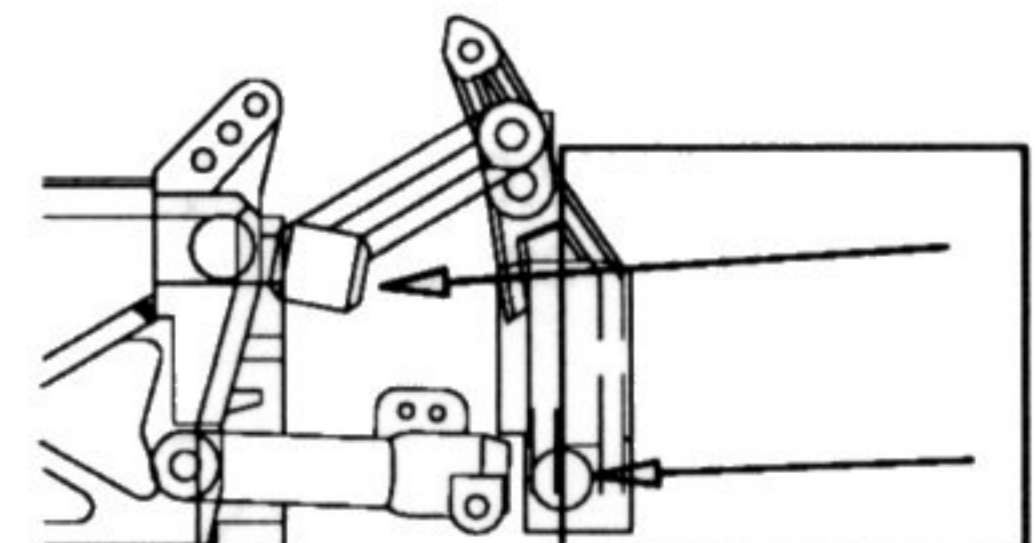
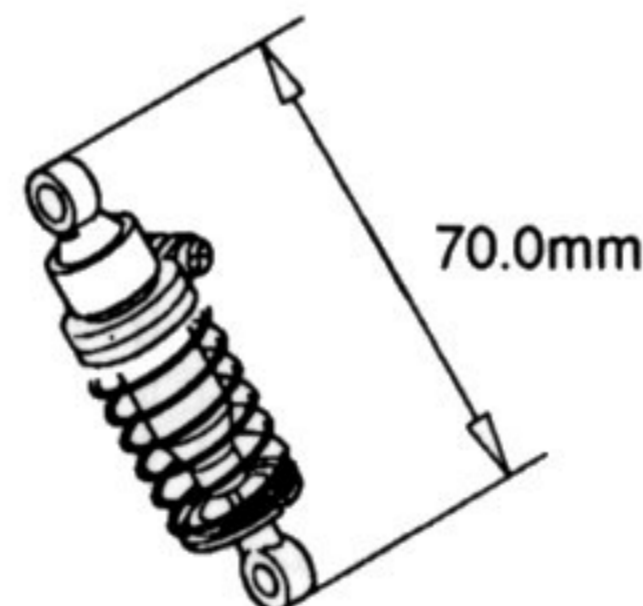
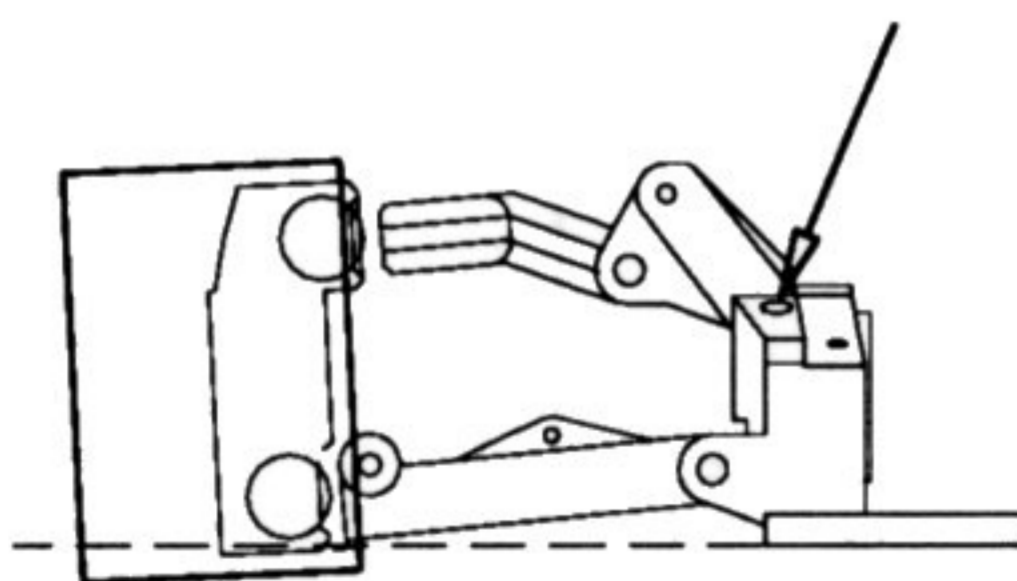

STEP 6: RIDE HEIGHT

Adjust the ride-height to the maximum, until the shockabsorbers are fully extended (full 60mm). The M4x10 setscrew in the front brackets are used for this purpose. Make sure the left and right lower arms have equal ride-height.

STEP 7: REAR SUSPENSION

Take the rear shocks off. Check the play and smooth movement of all the pivot balls and adjust the alu. M10 nuts if necessary. Check the total length of the rear shocks (70.0mm) adjust this with the nylon rod ends. Check also the pivot points of the rear shockabsorbers, they should be free.

STEP 8: TRACK WIDTH REAR

Adjust the track width to 266mm, left and right equally adjusted. Make sure the left and right wheels stay parallel. Use the bottom pivot-ball and the 2 upper pivot-balls to adjust the width.

SETTING-UP THE SERPENT EXCEL

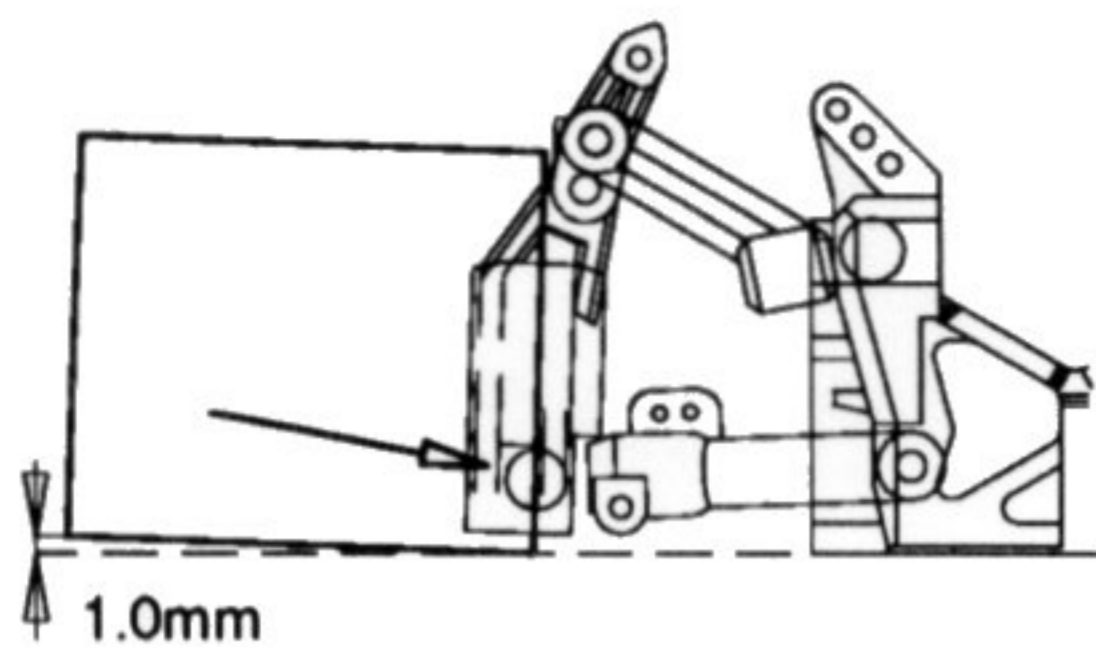

STEP 9: CAMBER ANGLE REAR
With the chassis flat on the ground the rear-wheel camber angle is adjusted. Adjust the bottom pivot-ball until the outside of the rim has 1.0mm clearance.

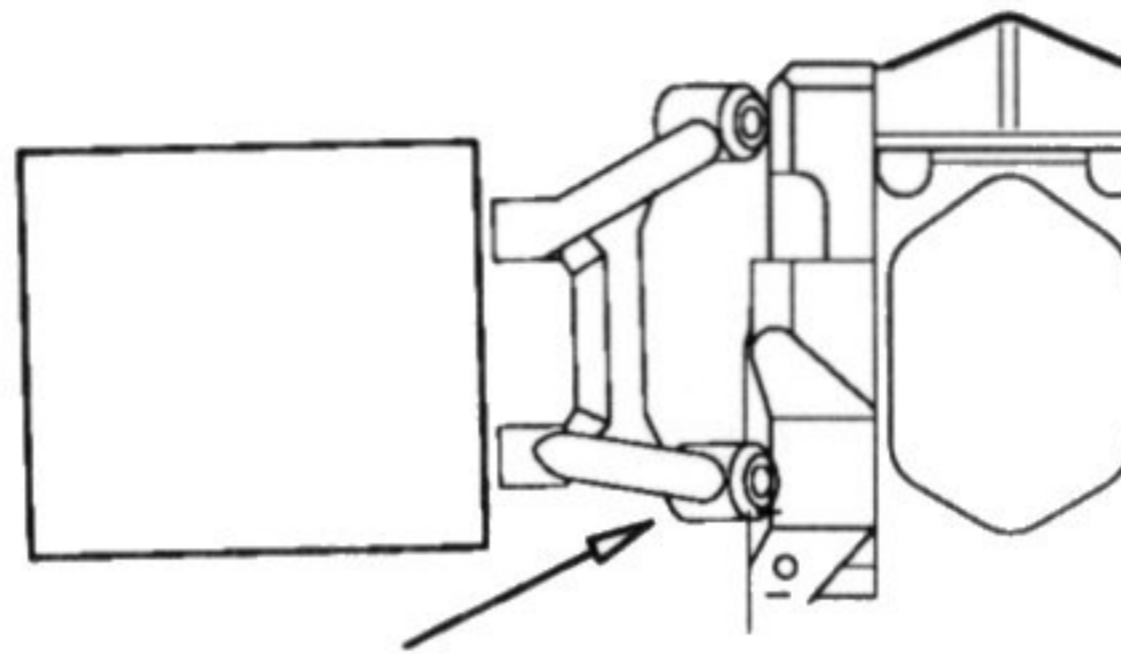

STEP 10: TOE-IN REAR
Adjust the toe-in of the rear wheel with the front pivot-ball in the upper suspension arms. Adjust the arm until the outside line from the rear rim cuts the outer edge of the front rim. Use a ruler or another straight piece to check this (see also the top-view diagram).

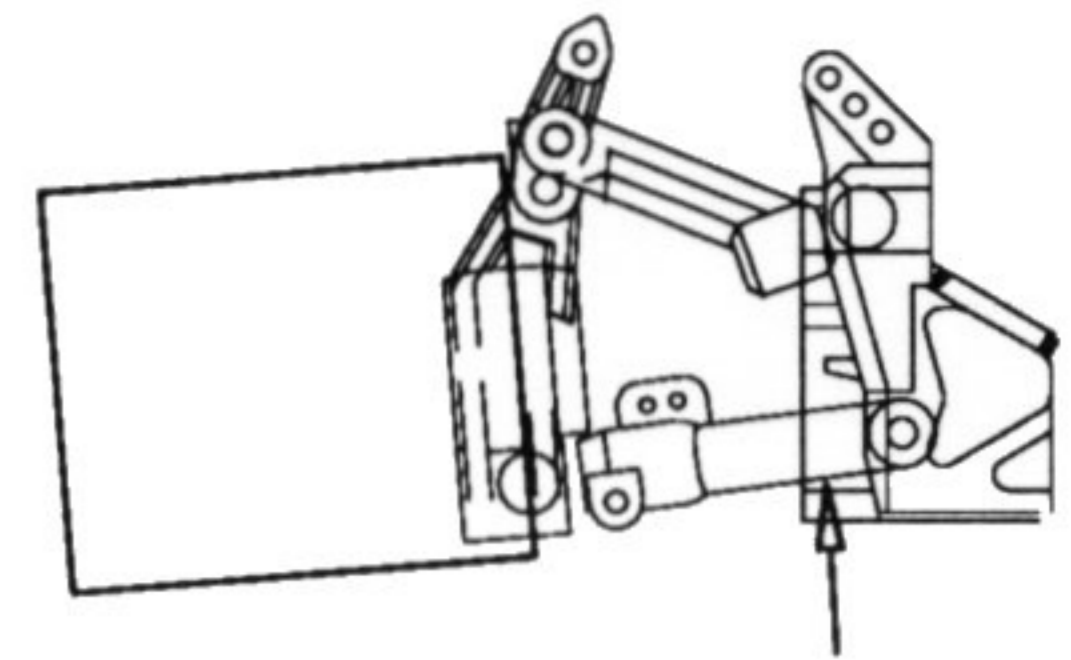

STEP 11: RIDE-HEIGHT REAR
The ride-height is adjusted with the M4x10 setscrew in the lower rear arms. Under normal circumstances the maximum ride-height is the best, so this screw is hardly necessary. Adjust the screws to allow maximum travel of the rear shocks, make sure right and left are adjusted equally.

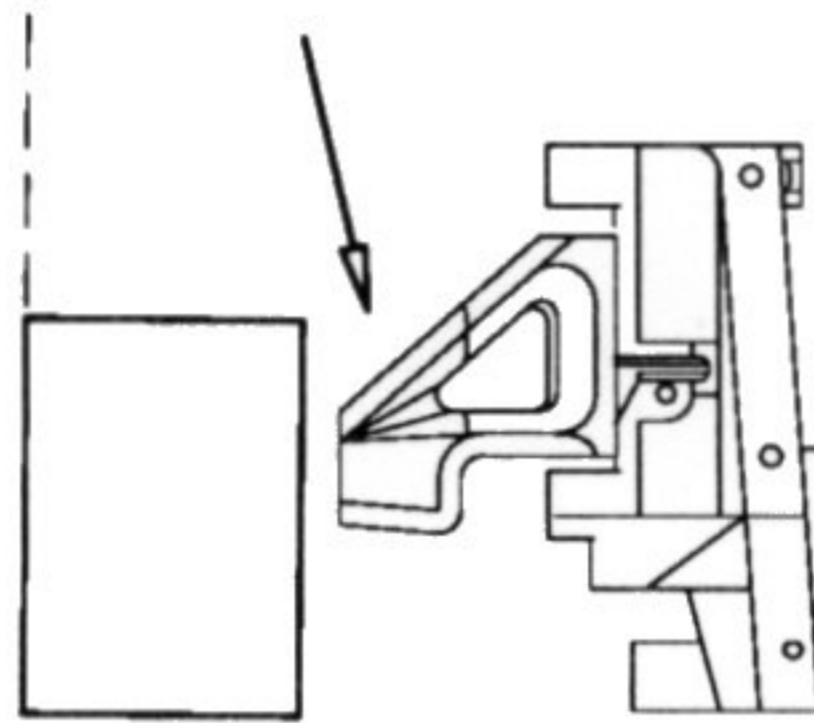

STEP 12: TOE-OUT FRONT The front wheels adjusted with a little toe-out. As a standard setting the line along the outside of the front rim should intersect the rear rim 6mm from the outside (see top view of the diagram). Turn the track-rods in the ball-joints that are attached to the servo-saver to adjust the required toe-out.

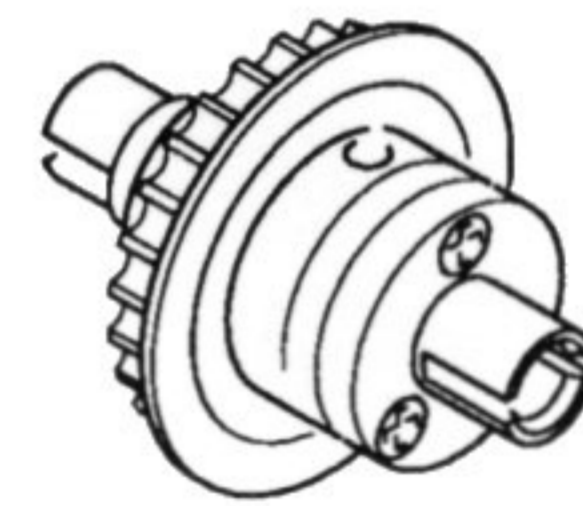

STEP 13: SHOCKABSORBERS
The front and rear shockabsorbers should be used with the blue label silicon oil, and set at medium damping. Use the standard springs, front 1.6mm (chrome #1614) and rear 1.4mm (chrome #1624). The spring tension is adjusted with the nylon rings. Optional are the alu. adjusting nuts (#6441). Other springs and oil are available, see parts list.

STEP 14: DIFFERENTIAL
The differential can be adjusted by tightening the clamping bushing. A tighter setting will give more steering into the corner, and better acceleration out of the corner. Setting the diff. is very much a track-side matter and depends on tire-choice and setting of the suspension. Alternatively the solid rear-axle can be used (#6380) or the unique FLEXDRIVE solid rear axle (#9330). The solid axle will give the car more steering out of the corner.

STEP 15: ANTI-ROLL BARS Check that the anti-roll bars are of equal length left and right, re-adjust if necessary. Also check the free-movement of the anti-roll bars so they do not obstruct the suspension. The stiffness can be altered by grinding the bar down. The rear anti-roll bar will become stiffer if the bottom balls are mounted in the outside holes of the lower suspension arms.

front	#9221	2.5mm
	#9222	3.0mm
rear	#9321	3.0mm
	#9322	2.5mm
	#9323	2.0mm

STEP 16: DRIVE RATIO
The drive ratio between the front and the rear wheels depends on the side pulleys (std. 19T/23T) and the tire diameters. The standard side pulleys should be used, the EXCEL does not require to overdrive the front wheels, this will result in killing the acceleration and the top-speed of the car. The standard selection is based on 9-10mm difference in tire diameter.

layshaft pully	middleshaft pully	diam. F	diam. R	overdrive front
19T	23T	70	80	- 3.6%
19T	23T	68	78	- 4.1%
19T	22T	70	80	+ 0.7%
19T	22T	68	78	+ 0.4%

STEP 17: TYRE CHOICE The tyre choice depends on track conditions. In general Serpent SUMO front tires are advised in hardness 35-40 shore (#6822 #6823). These tires give high traction combined with low wear. Rear tires are available in much more compounds and shore hardness. Softer rear tires normally make the car push more, so for both steering and tire wear reasons always try to use the hardest compound rear tires. Tire diameters could be selected as follows:

	qualifying	final
front	68mm	70mm
rear	78mm	80mm

Choice of tire diameter depends on tire-wear conditions of the track.



SERPENT MODEL RACING CARS
P.O. Box 180 2100 AD Heemstede Holland