

# SPYDER SRX2 MH

**MHT**  
MEDIUM-HIGH-TRACTION

**Instruction  
Manual**



**EP**  
1/10 2WD - Buggy

## INTRODUCTION

Thank you very much for selecting this Serpent rc car and thus become a member of the ever growing worldwide Serpent racing family. Serpent started in 1980 and has been growing its product-line and fan-base ever since.

The Serpent Spyder SRX2 MH is a state of the art 1/10 scale 2wd buggy which will give you the true Serpent racing experience. The assembly manual will guide you through all the steps to complete the car, so you can hit the track with a good base-set-up soonest. The Serpent design department succeeded to create a superbly performing car combined with eas of assembly and maintenance. The high quality standards of all parts and hardware will make racing your Serpent car a very rewarding activity!

The Spyder SRX2 MH kit includes 2 types of transmissions and each has its own manual. Use the LMT ( low-medium-traction) for the 3-gear standing transmission, and the MHT ( medium-high-traction) for the 3-gear laydown transmission. Carefully follow the A,B, C bag-numbering in the steps which apply to the transmissions.

Through our team, website and social media we will keep you up-to-date on all developments of the Serpent cars. We hope to meet you on the track and through our various media! Enjoy the drive!

Team Serpent  
Multiple World Champions

## INSTRUCTIONS

Serpent's long tradition of excellence extends to the instruction manuals, and this instruction manual is no exception. The easy-to-follow layout is richly illustrated with 3D-rendered full-color images to make your building experience quick and easy. Following the instructions will result in a well-built, high-performance race-car that will soon be able to unleash its full potential at the racetrack. The kit includes bags, with bagnumbers, which refer to the same step in the manual. Open only the indicated bag(s) per step and finish that part of the assembly. Remaining parts will be needed lateron in the assembly process.

## PLASTIC PARTS

The Serpent moulded parts are very durable and hard. When assembling longer screws in new composite parts, make sure to use new hex bits in your (power) tools. Pre-threading also helps to avoid screw damage.

## SETUP

In certain assembly steps you need to make basic adjustments, which will give you a good initial setup for your Serpent Cobra SRX8. Fine-tuning the initial setup is an essential part of building a high-performance racecar like your Serpent Spyder SRX2 MH.

## EXPLODED VIEWS AND PARTS LIST

The exploded views and parts lists for the Serpent Spyder SRX2 MH are presented in the Reference Guide section in the back of this manual. The exploded views show all the parts of a particular assembly step along with the Serpent part number and hotlink to the Serpent website. Partnumbers in orange indicates that this part is an optional. Optionals part names and numbers are showed below.

## CUSTOMER SERVICE

Serpent has made a strong effort to make this manual as complete and clear as possible. Additional info may be published in our website: [www.serpent.com](http://www.serpent.com) or you may ask your dealer or the Serpent distributor for advice, or email Serpent direct: [info@serpent.com](mailto:info@serpent.com). The Serpent Facebook, Twitter and Youtube pages give additional means of support and communications.

## SAFETY

Read and take note of the 'Read this First section' before proceeding to assemble the car-kit. This car-kit is intended for persons aged 16 or older.

## READ THIS FIRST!

- This is a highly technical hobby product, intended to be used in a safe racing environment. This car is capable of speeds in excess of 80 km/h or 50mph. Please follow these guidelines when building and operating this model.
- Parental guidance is required when the builder/user of this car is under 16.
- Follow the building instructions. If in doubt, contact your dealer or importer.
- Be sure to use the proper toolsz when assembling the car. Always exercise caution when using electric tools, knives and other sharp objects.
- Be careful when using liquids like lubrication oil, fuel or glue. Do not swallow.
- Follow the manufacturer's instruction in case you experience irritation after using the product.
- Be careful when operating the car. Stay away from any rotating parts such as wheels, gears and transmission. Stay away from motor, engine and exhaust pipe system or speedo during and immediately after use, as these parts may be very hot. We advise to use protective hand cloves.
- Only operate this car in a safe environment, like a special racing track or a closed parking lot. Avoid using this car on public roads, crowded places or near infants.
- Before operating this car, always check the mechanical status of the car. Also check that the transmitter and receiver frequencies correspond and are not used by any other racer at the same time. Check that the batteries of the transmitter and receiver- are fully charged.
- After use, always check all the mechanics of the car. We advise to clean the car immediately after use, and inspect the parts for wear or fractures. Replace when necessary. Do not use water, methanol, thinner or other solvents to clean the car.
- Empty the fuel tank (depending on model) if needed and disconnect the receiver battery.
- Store the car in a dry and heated place to avoid corrosion of metal parts.
- Avoid using this car in wet conditions as the water will cause corrosion on the metal parts and bearings and these parts will cease to function properly. If driven in the wet, ensure that all the electric equipment is waterproofed and after use, that all moving parts are dried immediately.

## CONTENTS

• <b>CHASSIS ASSEMBLY</b>	<b>4</b>
• <b>STEERING ASSEMBLY ASSEMBLY</b>	<b>5</b>
• <b>FRONT ASSEMBLY</b>	<b>7</b>
• <b>REAR ASSEMBLY</b>	<b>11</b>
• <b>DIFF ASSEMBLY</b>	<b>15</b>
• <b>TRANSMISSION ASSEMBLY</b>	<b>17</b>
• <b>SHOCKS ASSEMBLY</b>	<b>27</b>
• <b>FINAL ASSEMBLY</b>	<b>30</b>
• <b>EXPLODED VIEWS</b>	<b>34</b>
• <b>TEAM SERPENT NETWORK</b>	<b>44</b>

## LINES DESCRIPTION

Each step contains a variety of numbers, lines, and symbols. The numbers represent the order in which the parts should be assembled. The lines are described below.



Step number; the order in which you should assemble the indicated parts



Length after assembly



Assembly path of one item into another



Group of items (within lines) should be assembled first



Direction the item should be moved



Glue one item to another



Connect one item to another



Gap between two items



Press/Insert one item into another

## ICONS DESCRIPTION

Each step contains a variety of symbols described below.



Carefull, read and check very well.



Apply a small amount of cyano glue. Use wear protection for eyes and hands.



Detail view to explain assembly or order of parts better.



Default set-up: This symbol indicates the default setup.



Grease: apply a small amount of grease to the parts shown.



Silicone grease: apply a small amount of grease to the parts shown.



Thread lock: apply a small amount on the parts shown. Before to apply the threadlock, make sure to degrease the parts very well, as otherwise the threadlock will not work.



Silicone oil: use the indicated silicone oil for the shocks and differentials.



Oil: apply a small amount of oil to the parts shown.



Left and right parts should be assembled in the same way.



Parts or items not included in the kit.



Optional part, not standard in the kit.

## STEP 1 BAG 1

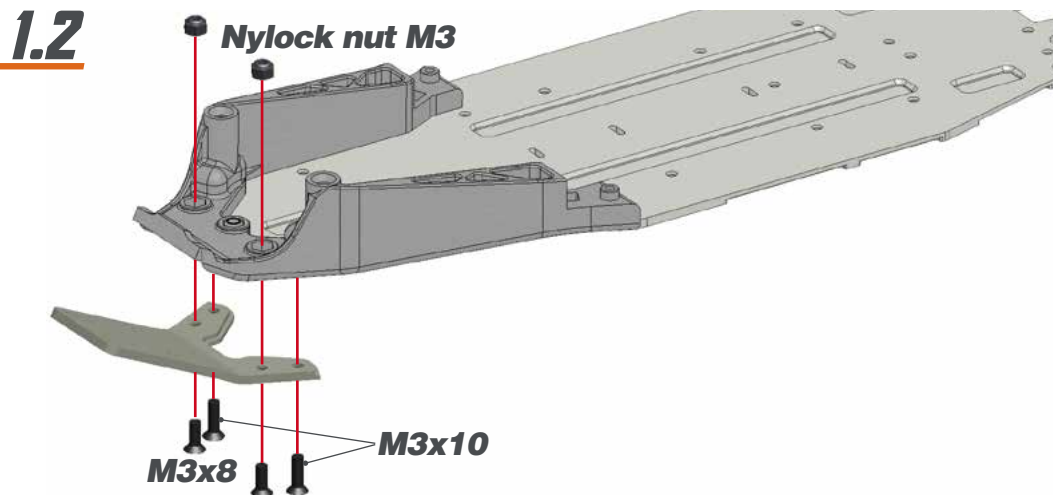
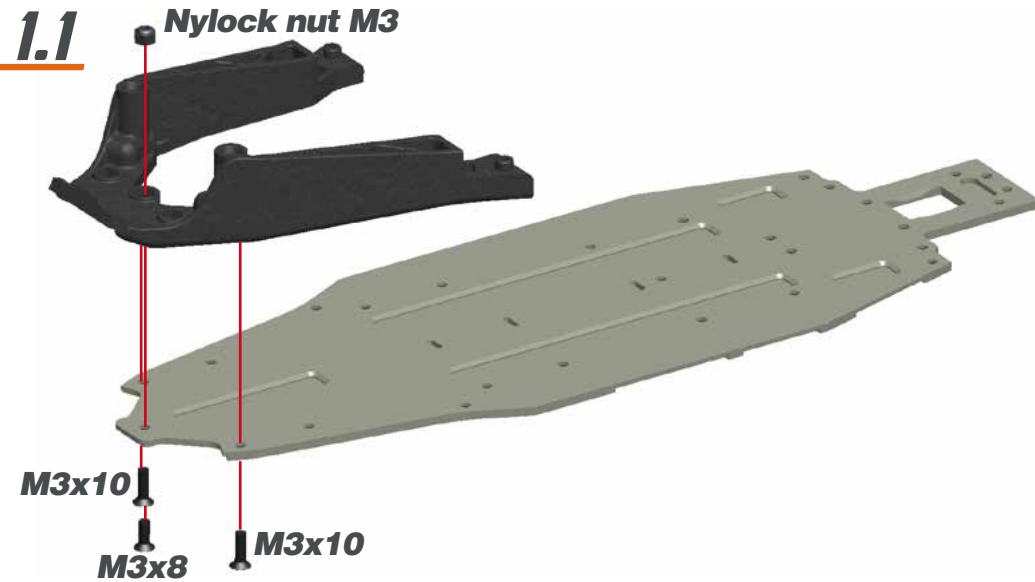

## STEP 2

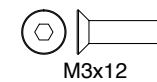
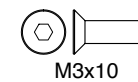
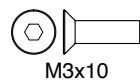
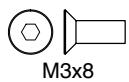
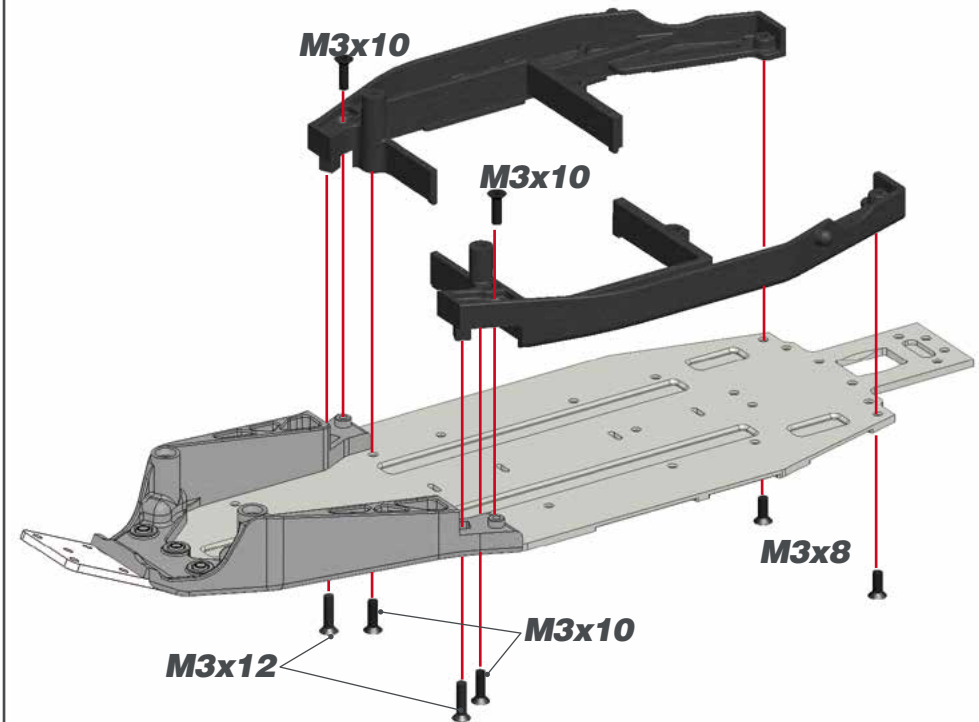

## STEP 3

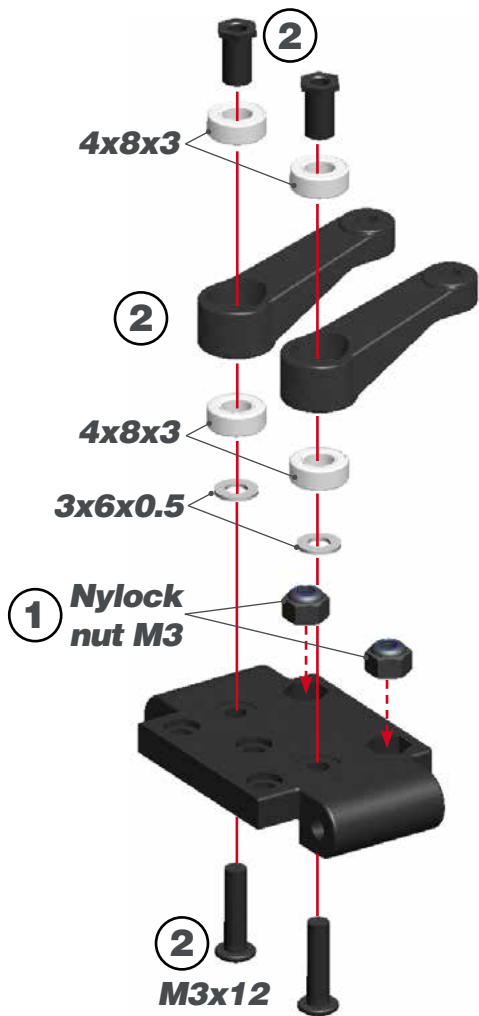

## STEP 4

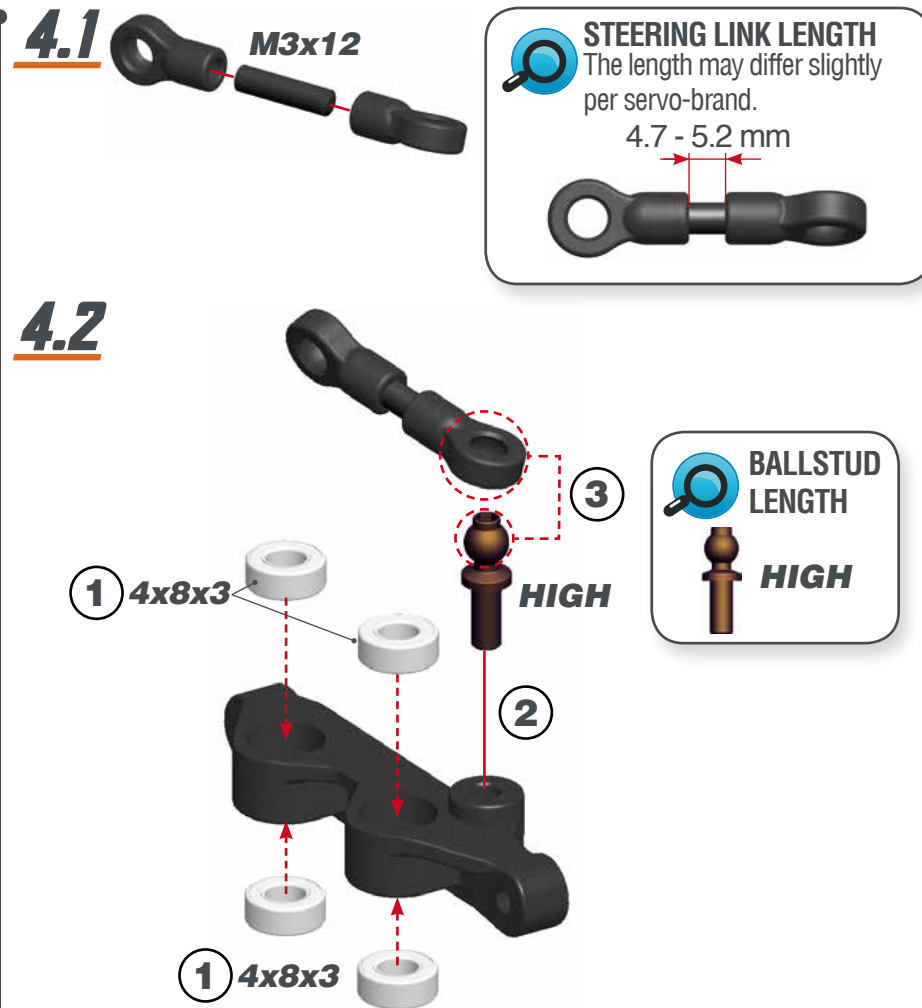

**STEERING LINK LENGTH**  
The length may differ slightly per servo-brand.  
4.7 - 5.2 mm

**BALLSTUD LENGTH**  
HIGH

## STEP 5

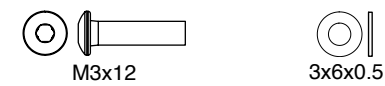
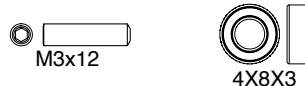
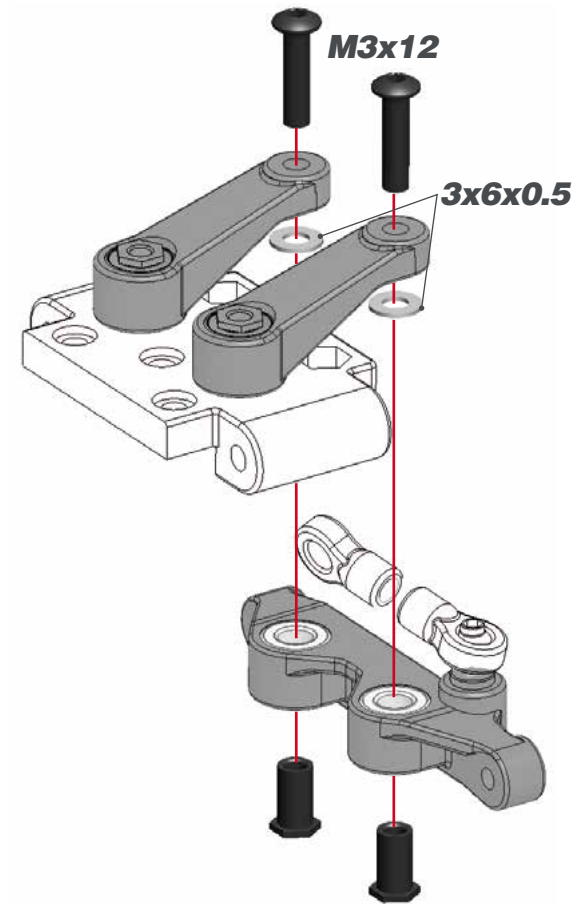

# STEP 6

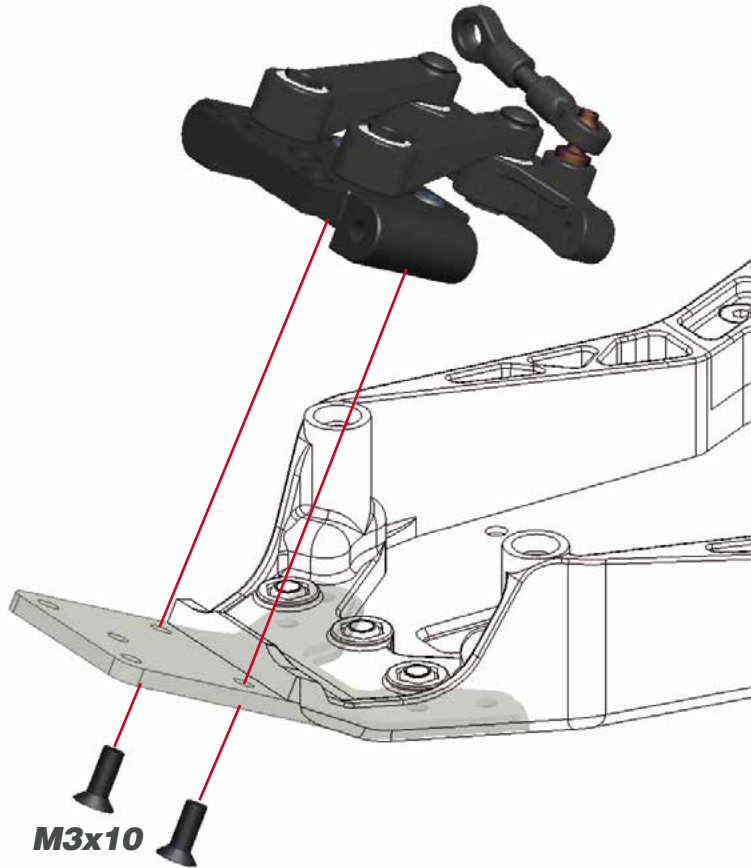

# STEP 7

## 7.1



1- Check how many teeth your servo spline has (23, 24 or 25) and use the right lever.  
2- Make sure to put the servo in neutral before mounting the lever.

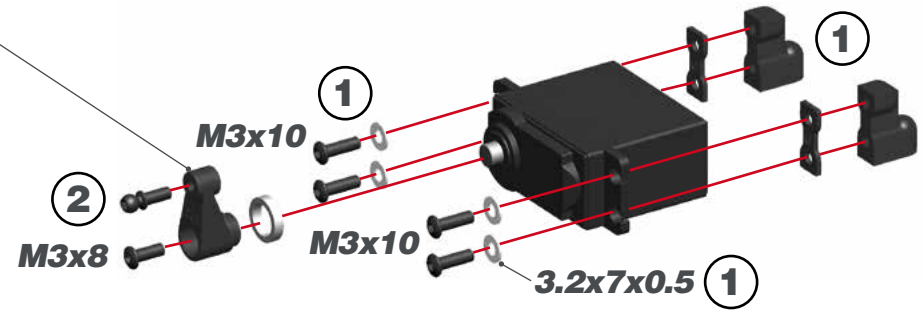

## 7.2

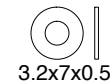
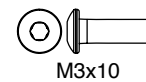
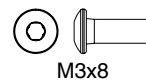
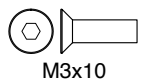
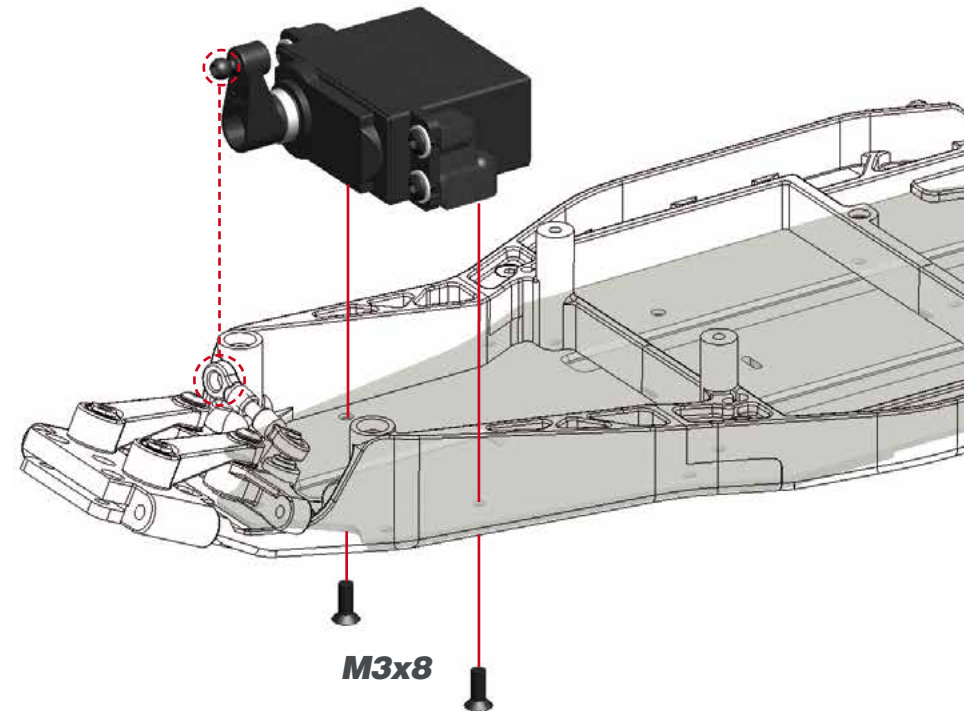

## STEP 8

## STEP 9 BAG 2

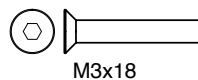
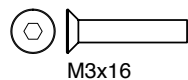
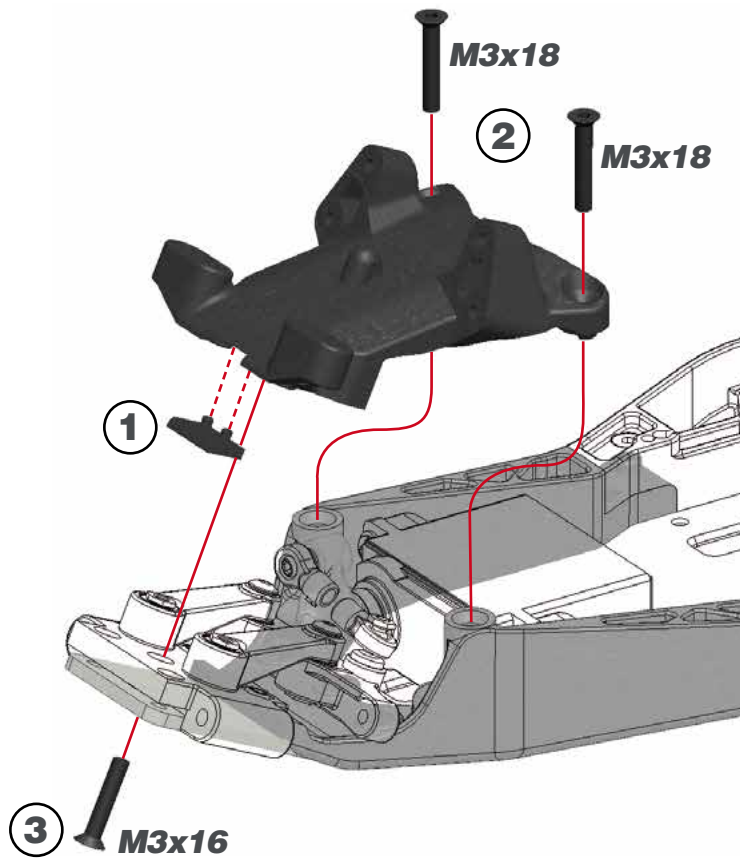

### 9.1

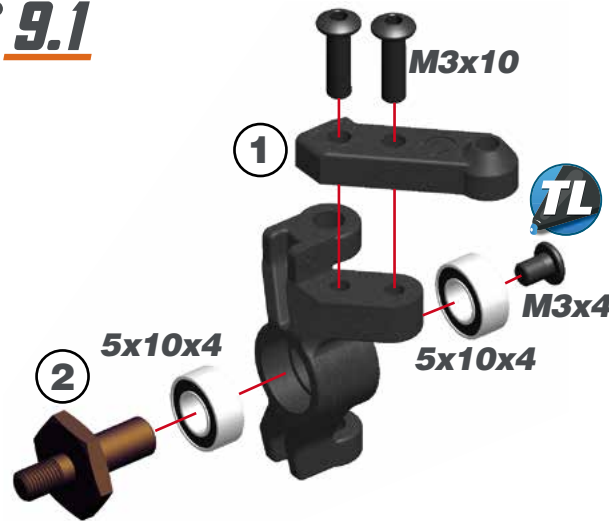

**L=R STEERING ARMS CHART**

**MORE ACKERMANN** ↔ **LESS ACKERMANN**

**DEF. SETUP**

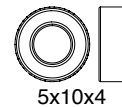
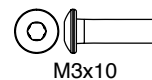
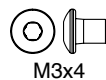

### 9.2

**!** Place the caster shims and the bushings in the steering block first. Then slide the assembly onto the casterblock.

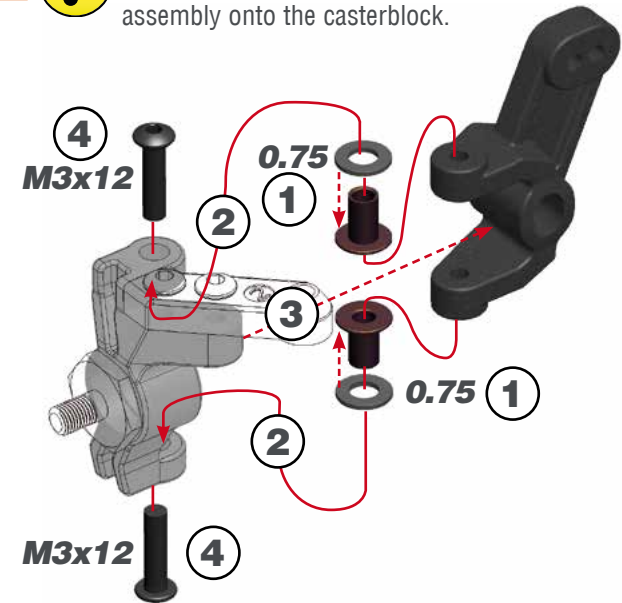

**STEERINGBLOCK ASSEMBLY**

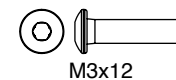

# STEP 10

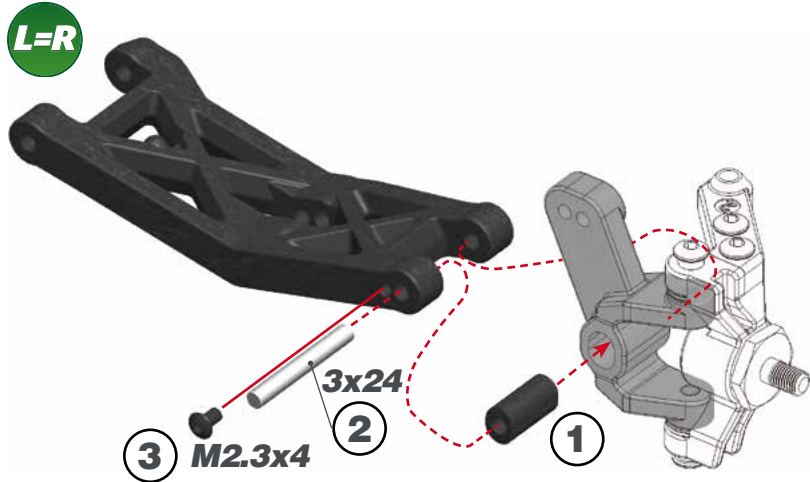

# STEP 11

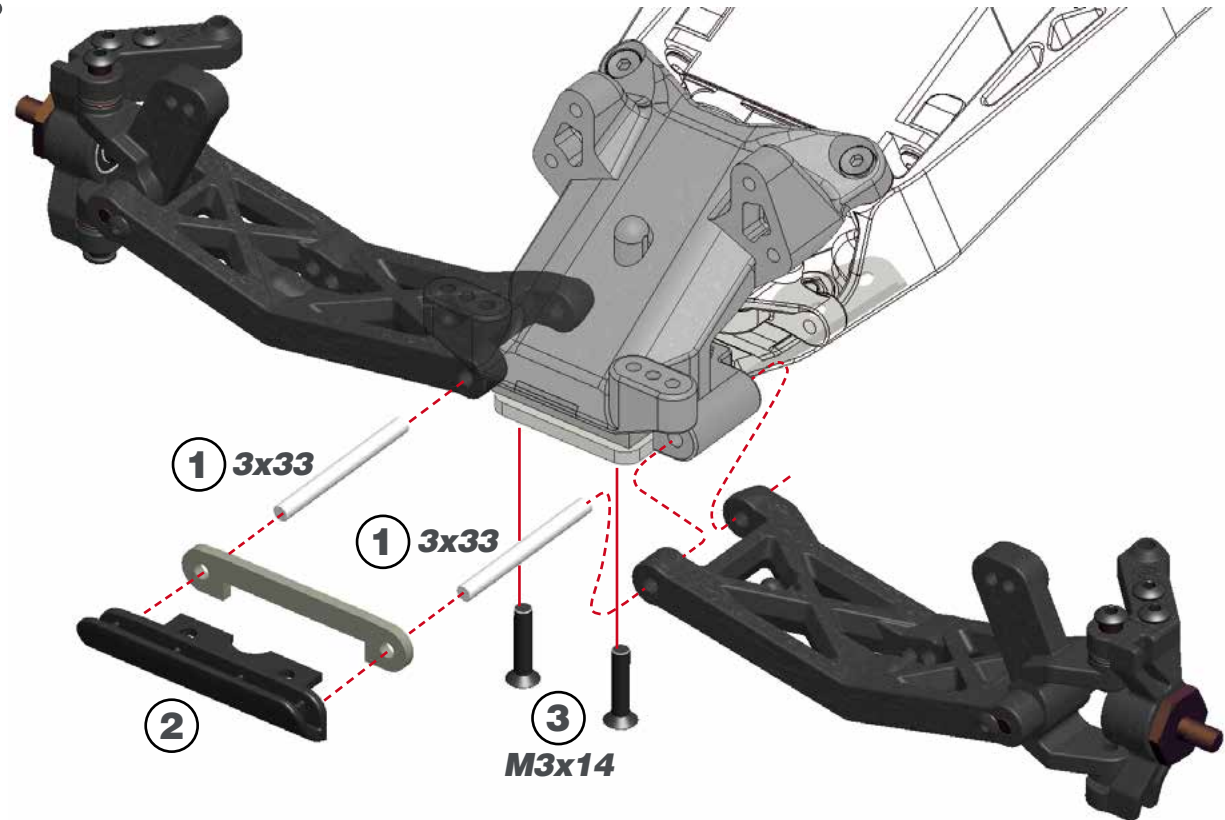

**L=R CASTER BLOCK INSERTS CHART**

Front default caster angle is 25° using the 0° default insert. You can add or remove caster using the different inserts included in the kit. It is possible to adjust the caster angle from 20° to 30° in 2.5° steps according to the chart shown below:

	2.5°	5°
<b>+ Caster</b>	25° POS	5° POS
<b>- Caster</b>	25° POS	5° POS

FRONT ← → REAR

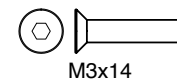



# STEP 12

## 12.1



**L=R FRONT CAMBERLINK LENGTH**

**DEF. SETUP**

27.3 mm

## 12.2

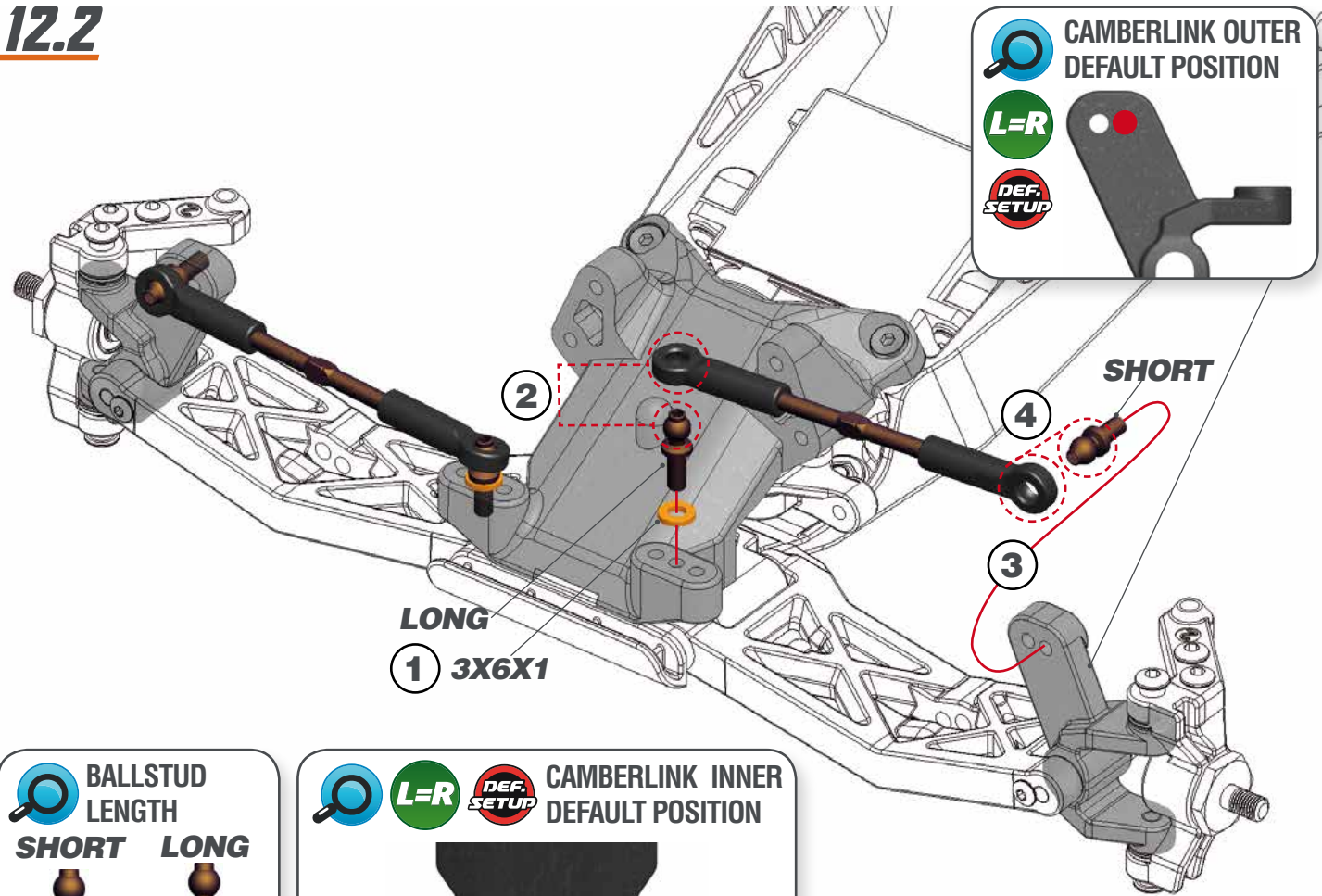

**BALLSTUD LENGTH**

**SHORT LONG**

**L=R DEF. SETUP CAMBERLINK INNER DEFAULT POSITION**



# STEP 13

## 13.1



**DEF. SETUP** STEERING TRACKROD LENGTH

**L=R**

31.4 mm

## 13.2

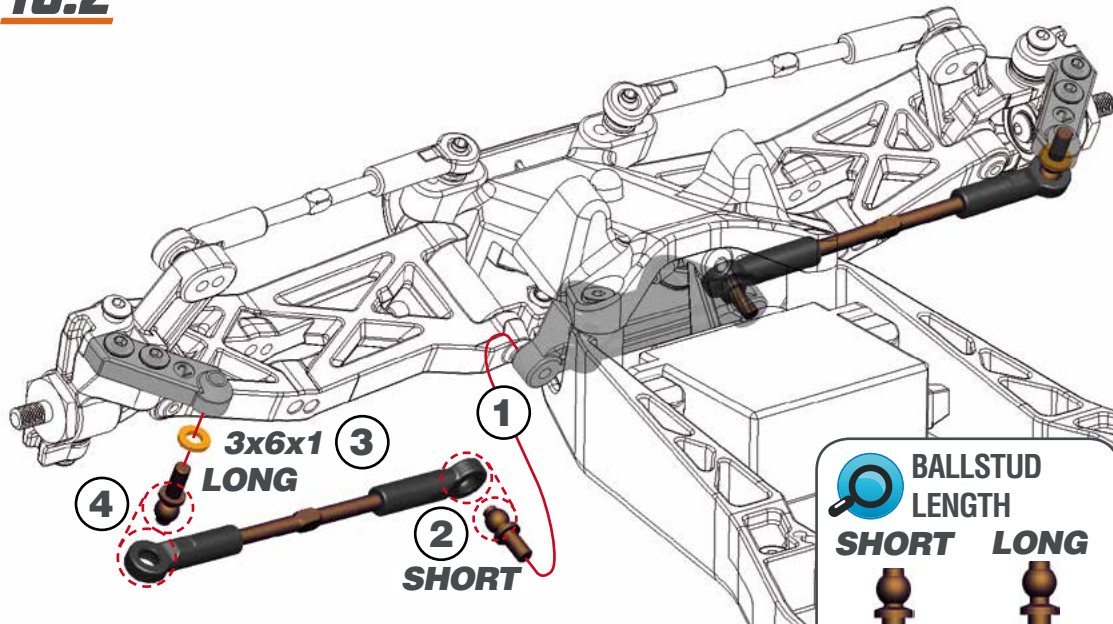

**BALLSTUD LENGTH**

**SHORT LONG**

# STEP 14

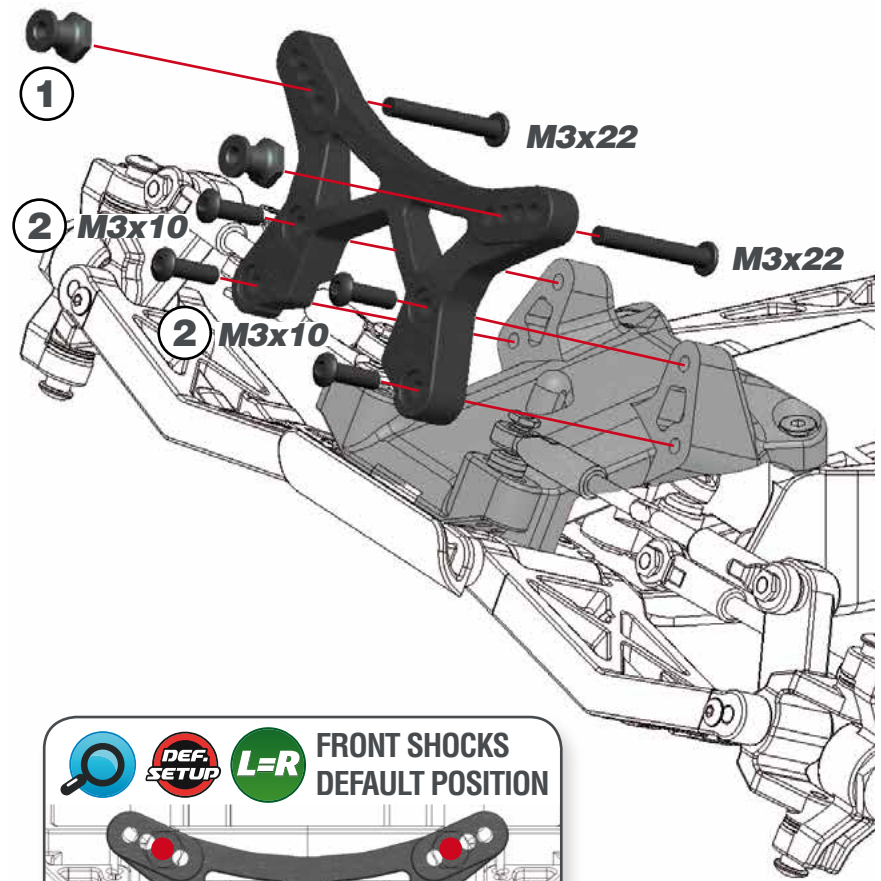

**DEF. SETUP** **L=R** FRONT SHOCKS  
DEFAULT POSITION

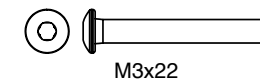
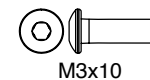

## STEP 15

## BAG 3

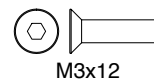
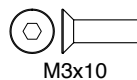
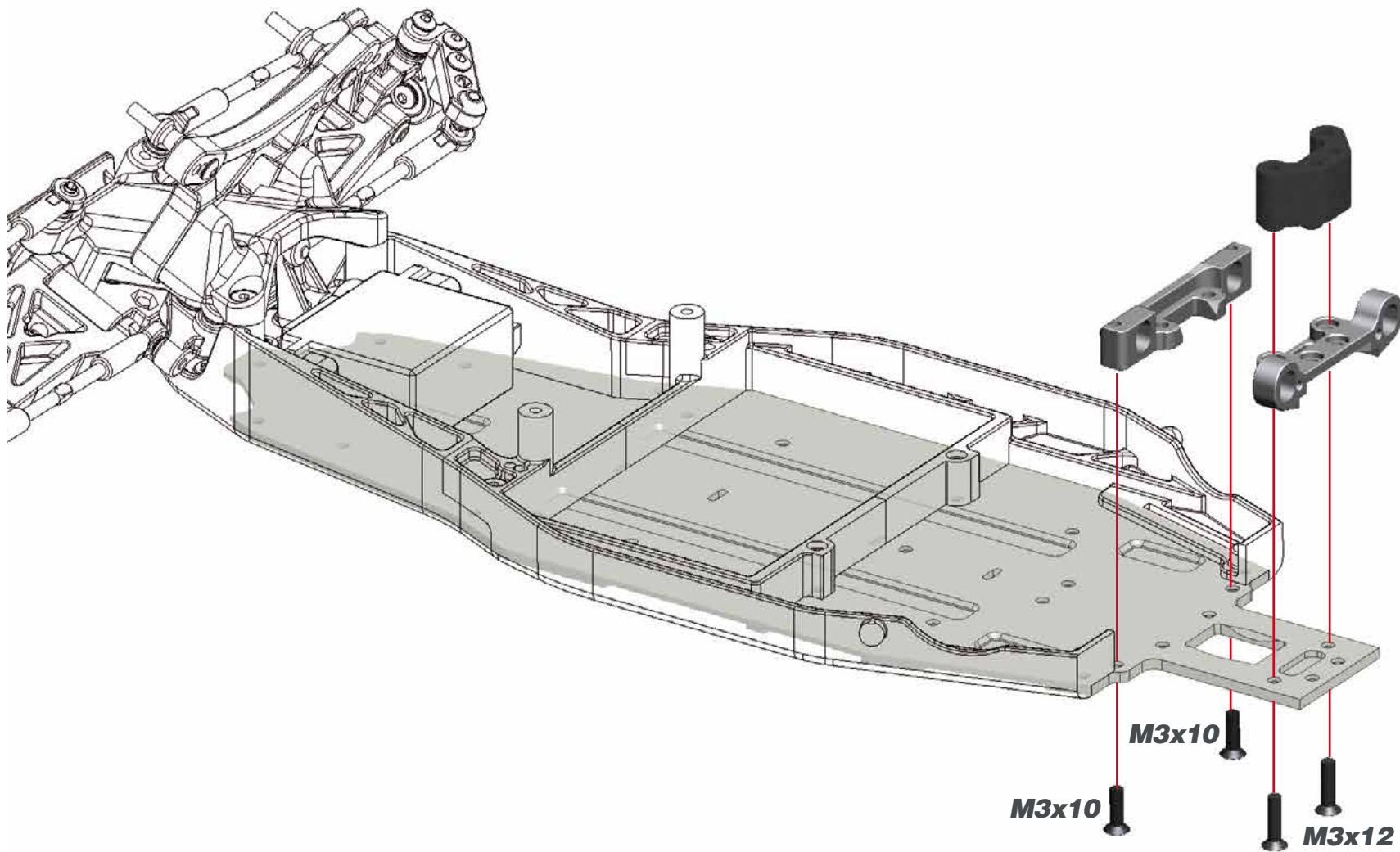

STEP 16

L=R

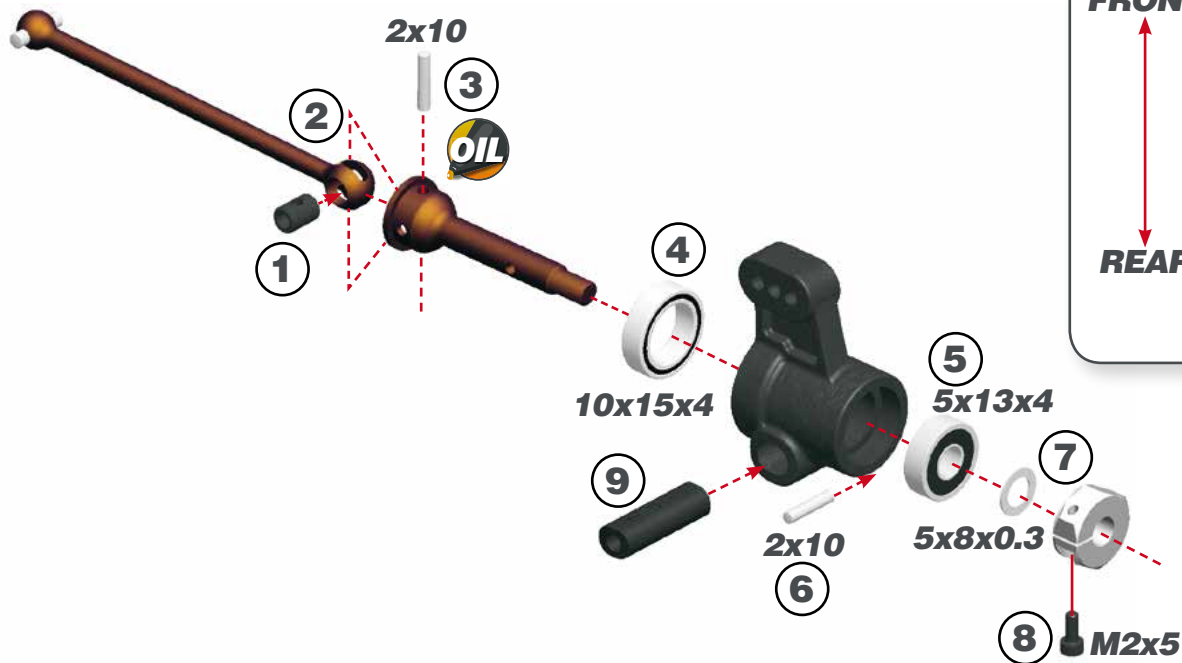

**L=R** REAR UPRIGHT TOE IN INSERTS

Rear toe-in is established by the rear suspension inserts assembled in step 18. Rear upright inserts are used to fine tune easily the rear toe in. For instance, if the suspension inserts give  $-4^\circ$  toe in and then is assembled the  $+1.5^\circ$  the resulting toe in is  $-2.5^\circ$ . Upright inserts are marked with a R for the right side and L for the left side.

FRONT		0.5°		1°		1.5°		2°	
		L	R	L	R	L	R	L	R
↑	DEF. SETUP	+ Toe in							
		0.5 L	0.5 R	1.0 L	1.0 R	1.5 L	1.5 R	2.0 L	2.0 R
↓		- Toe in							
		0.5 L	0.5 R	1.0 L	1.0 R	1.5 L	1.5 R	2.0 L	2.0 R

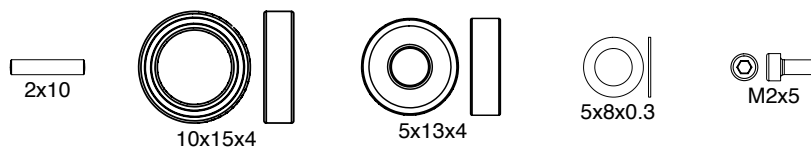

# STEP 17

**!** Notice that rear uprights are not symmetrical. Check below the correct position of each.

**FRONT**

**LEFT**

**RIGHT**

**REAR**

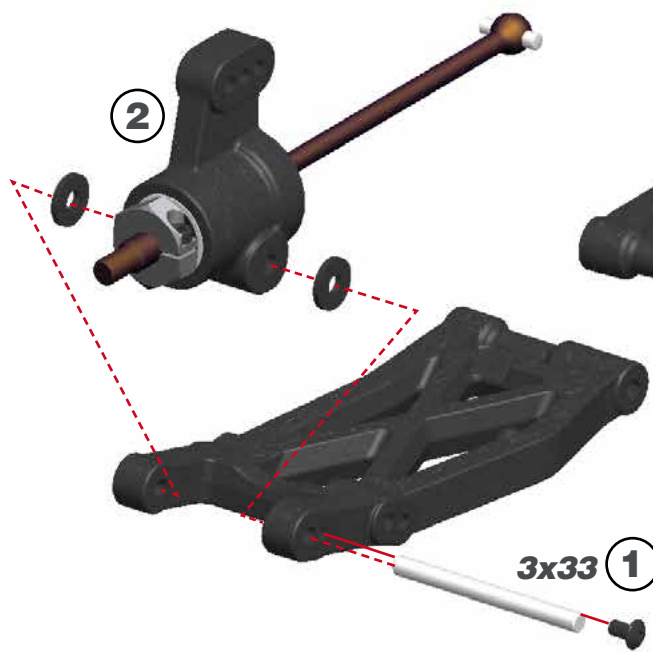

**REAR DEFAULT WHEELBASE SHIMS**

DEF. SETUP L=R

3x33 **1**

M2.3x4 **3**

3x33 **1**

M2.3x4 **3**



# STEP 18

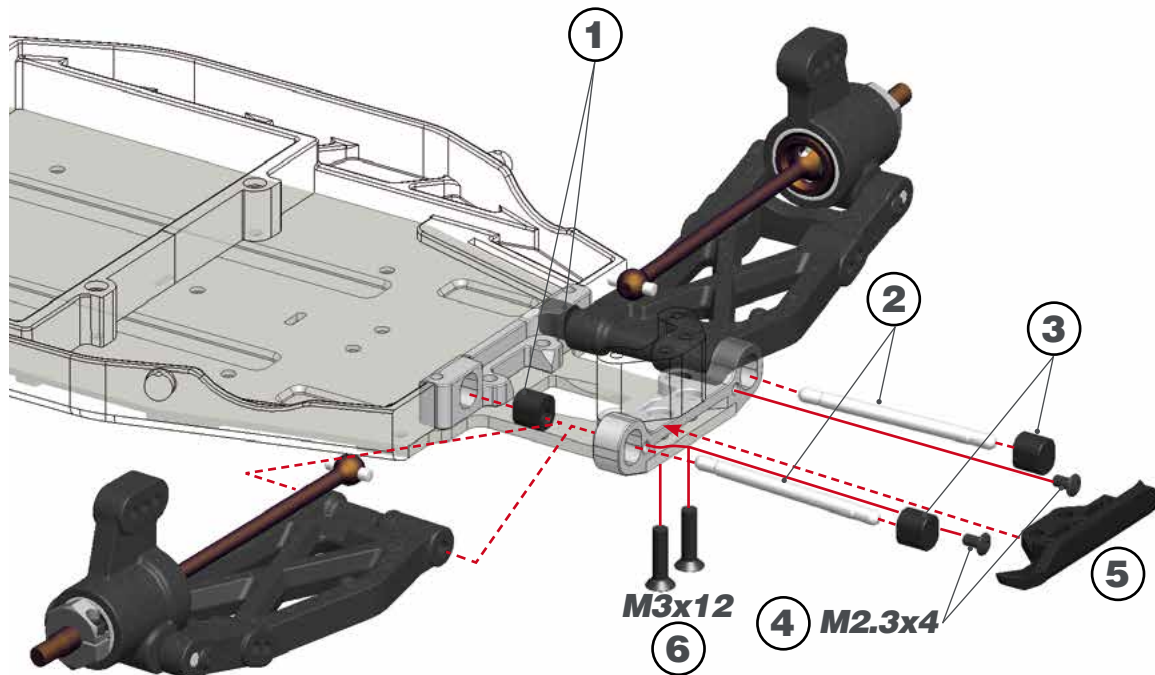

## **L=R** SUSPENSION INSERTS

The Serpent SRX2 MH is supplied with a set of inserts with which you can change the rear roll center and the rear track width. As you can see in the right chart you can move in and out and up and down the rear pivot pins adjusting also the rear anti-dive.

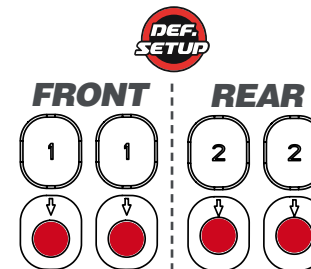

	NARROW		MID		WIDE	
↑ UP	↑	↑	↑	↑	↑	↑
	↔0	0↔	0	0	0↔	↔0
	↑	↑	↑	↑	↑	↑
	↔1	1↔	1	1	1↔	↔1
↓ DOWN	↑	↑	↑	↑	↑	↑
	↔2	2↔	2	2	2↔	↔2
	↓	↓	↓	↓	↓	↓
	↔1	1↔	1	1	1↔	↔1
	↓	↓	↓	↓	↓	↓
	↔0	0↔	0	0	0↔	↔0
	↓	↓	↓	↓	↓	↓
	↔0	0↔	0	0	0↔	↔0

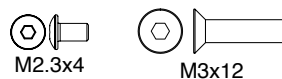

## STEP 19

### DIFF BAG

### 19.1

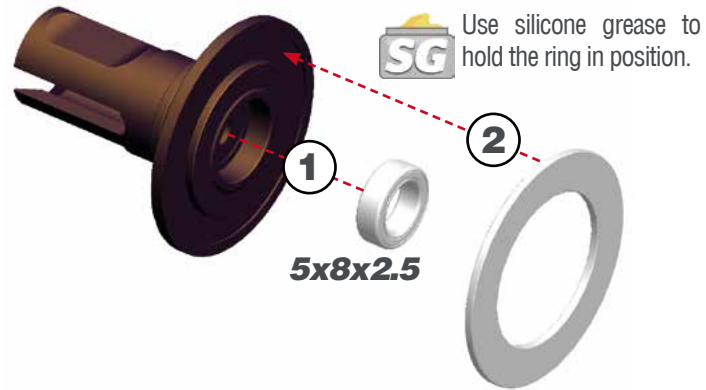

### 19.2

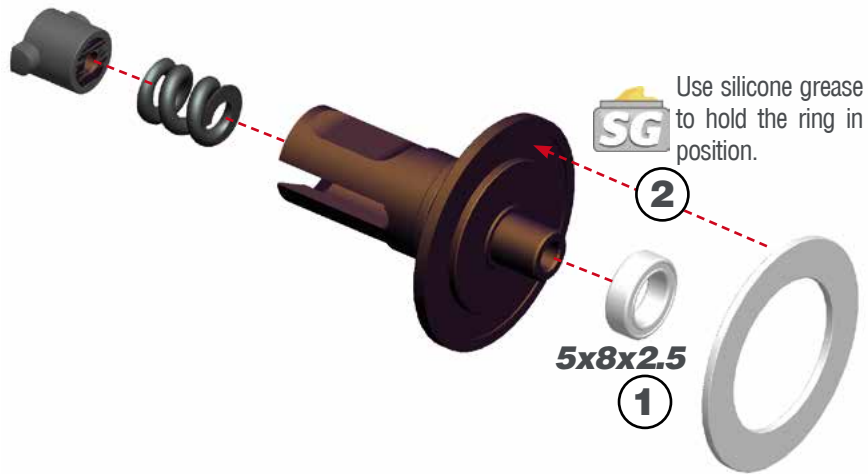

## STEP 20

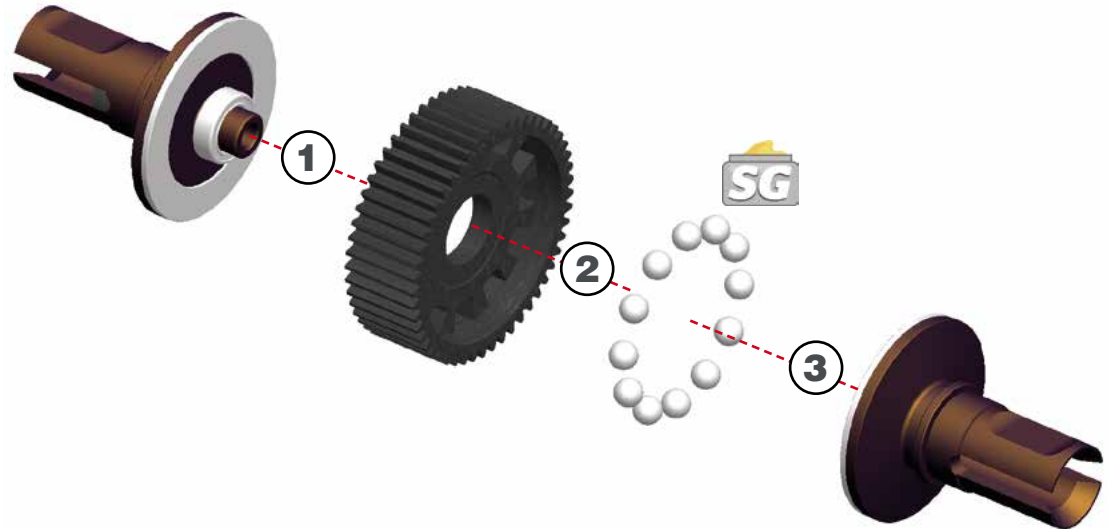

## STEP 21

## STEP 22

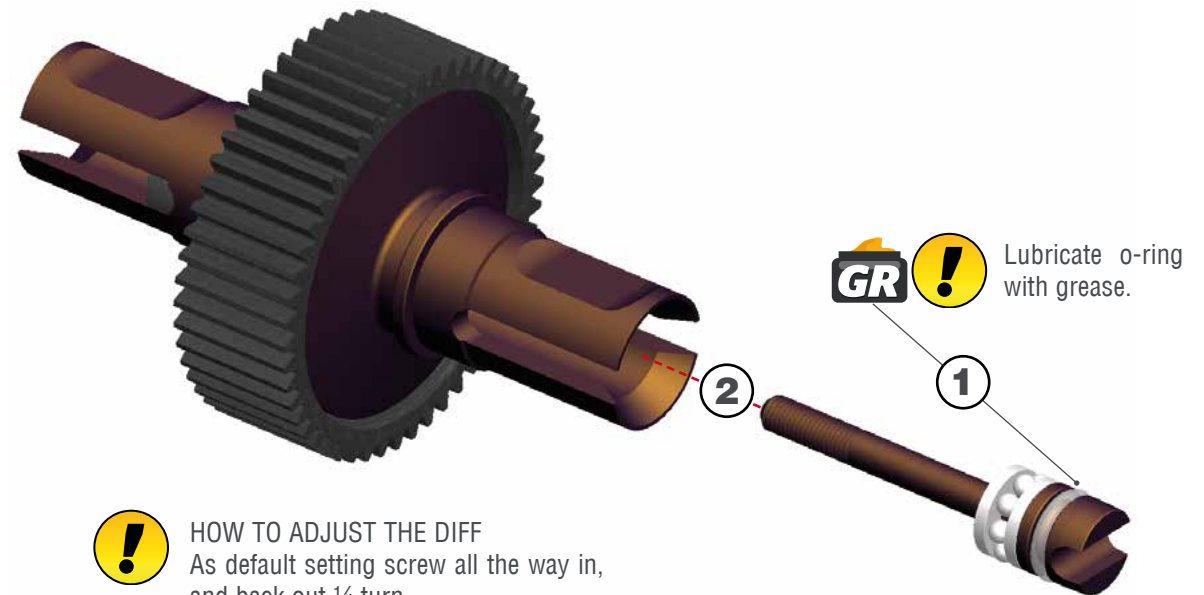
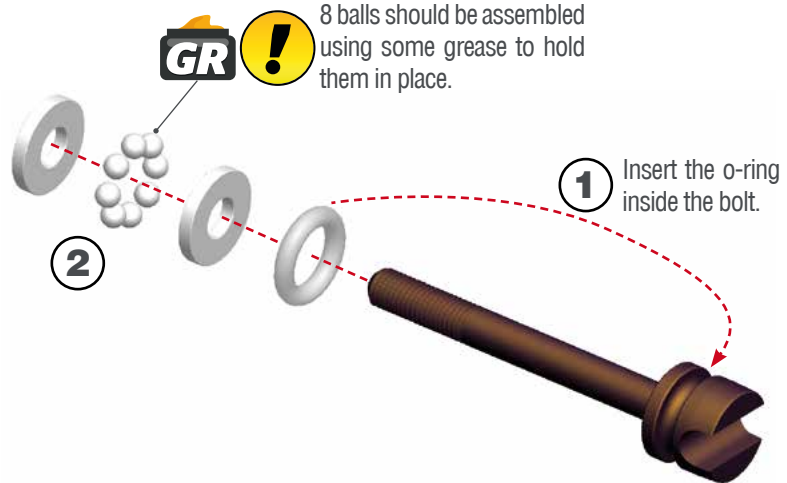

**!** HOW TO ADJUST THE DIFF  
As default setting screw all the way in, and back out ¼ turn.

**DEF. SETUP** Make small adjustments depending on the track condition.



## STEP 23

### BAG 4 A+C

Depending on the choice of transmission (3-gear standing or 3-gear laydown) choose the correct sub-bag for assembly.

#### 3 GEARS LAYDOWN TRANSMISSION **DEFAULT**



**DIFF HEIGHT SETTING**

Using different idler and diff inserts is it possible to move the diff up or down. Adapt the idler and diff, and left and right insert accordingly.

**LEFT**

**LOW**



**MID**



**HIGH**



**RIGHT**

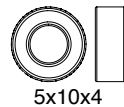
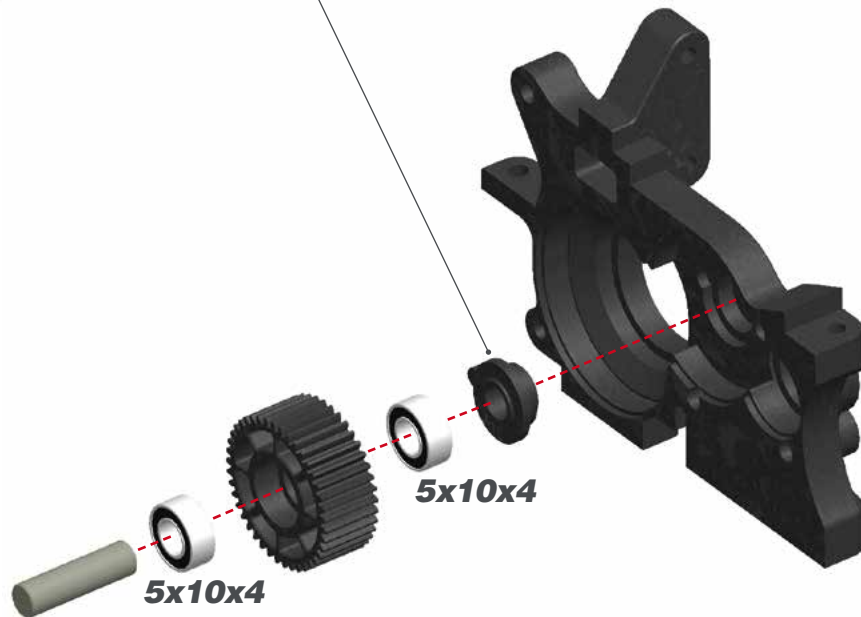

5x10x4

#### 4 GEARS LAYDOWN TRANSMISSION **OPTIONAL (NOT INCLUDED)**



**DIFF HEIGHT SETTING**

Using different idler and diff inserts is it possible to move the diff up or down. Adapt the idler and diff, and left and right insert accordingly.

**LEFT**

**LOW**



**MID**



**HIGH**



**RIGHT**

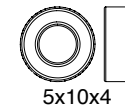
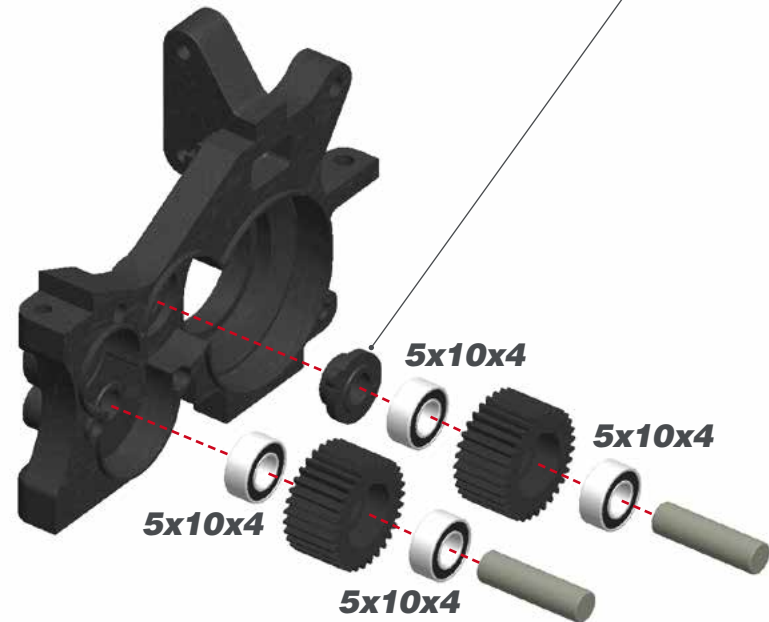
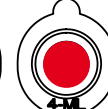

5x10x4

# STEP 24

## 3 GEARS LAYDOWN TRANSMISSION *DEFAULT*

**L=R** DIFF HEIGHT SETTING

Change the indicated inserts to move the diff up or low. Inner part of right insert is shown below pictures.

**LOW**   **MID**   **HIGH**

**DEF. SETUP**

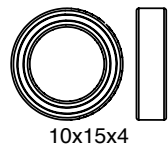
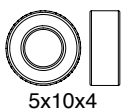
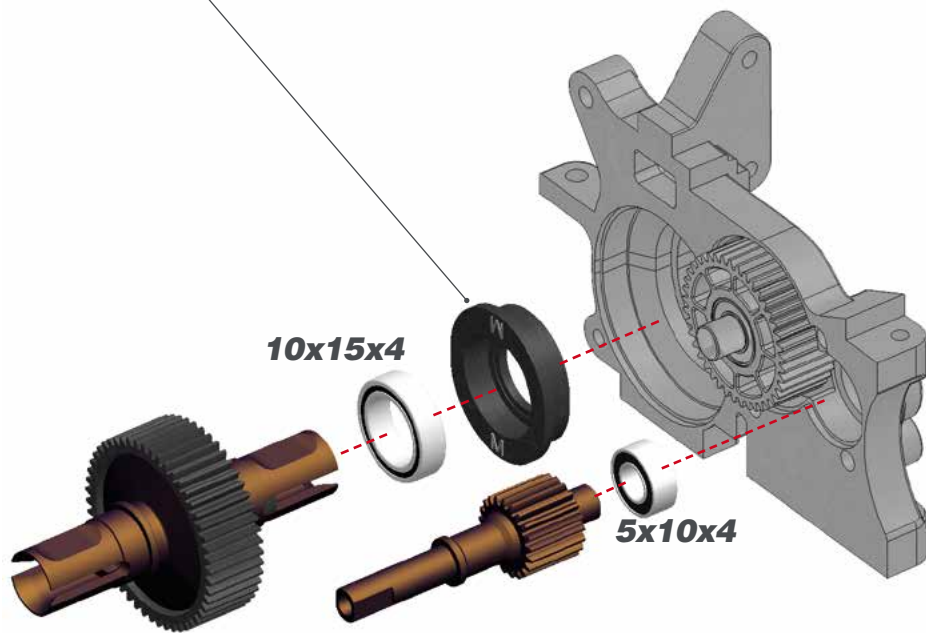

## 4 GEARS LAYDOWN TRANSMISSION *OPTIONAL (NOT INCLUDED)*

**L=R** DIFF HEIGHT SETTING

Change the indicated inserts to move the diff up or low. Inner part of right insert is shown below pictures.

**LOW**   **MID**   **HIGH**

**DEF. SETUP**

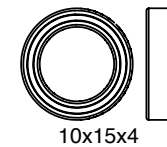
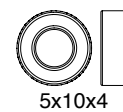
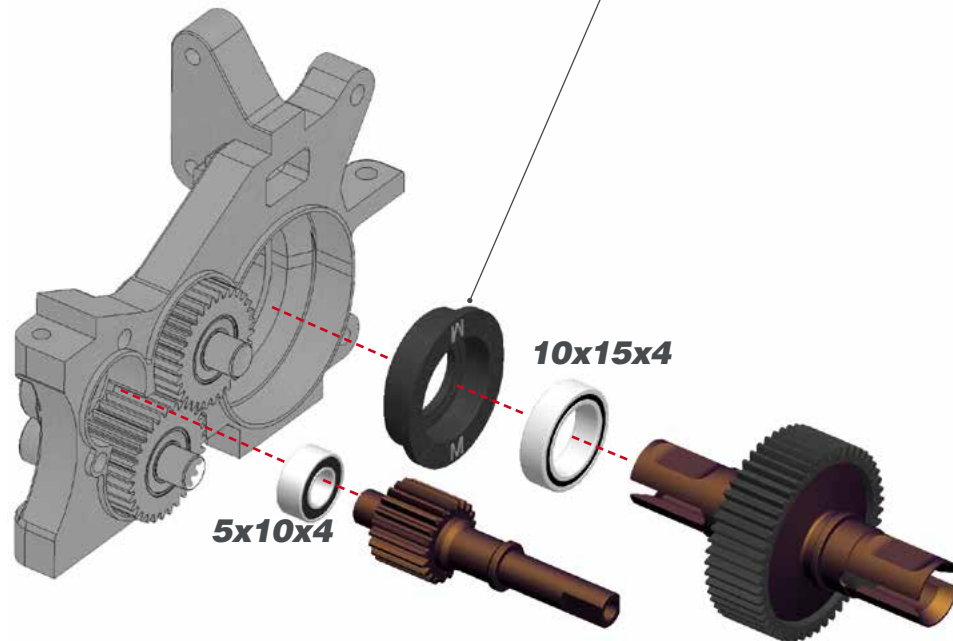

# STEP 25

## 3 GEARS LAYDOWN TRANSMISSION **DEFAULT**

**!** Remember to assemble the right idler and diff insert accordingly to the inserts assembled in the left side in the previous steps.

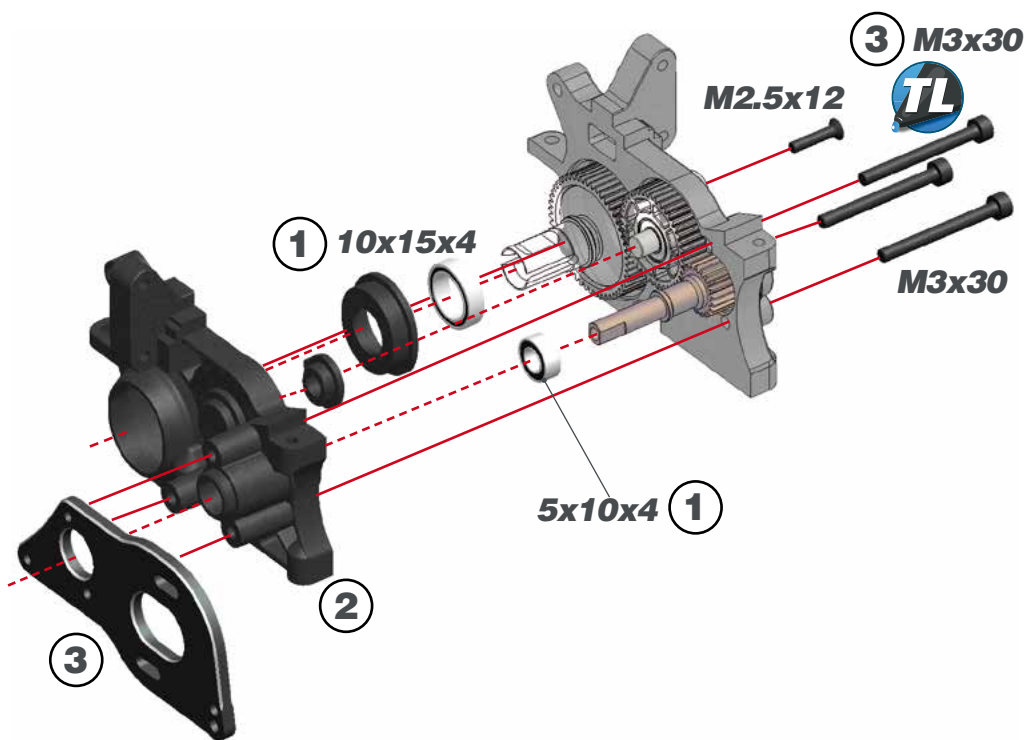

## 4 GEARS LAYDOWN TRANSMISSION **OPTIONAL (NOT INCLUDED)**

**!** Remember to assemble the right idler and diff insert accordingly to the inserts assembled in the left side in the previous steps.

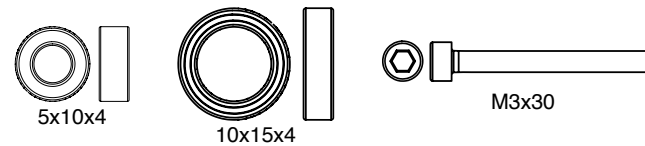
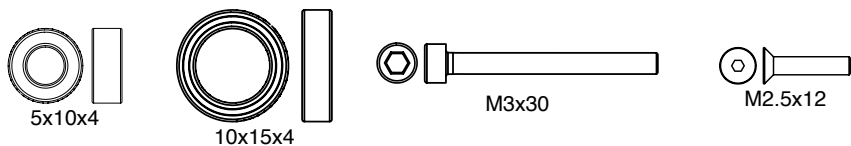
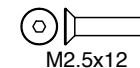
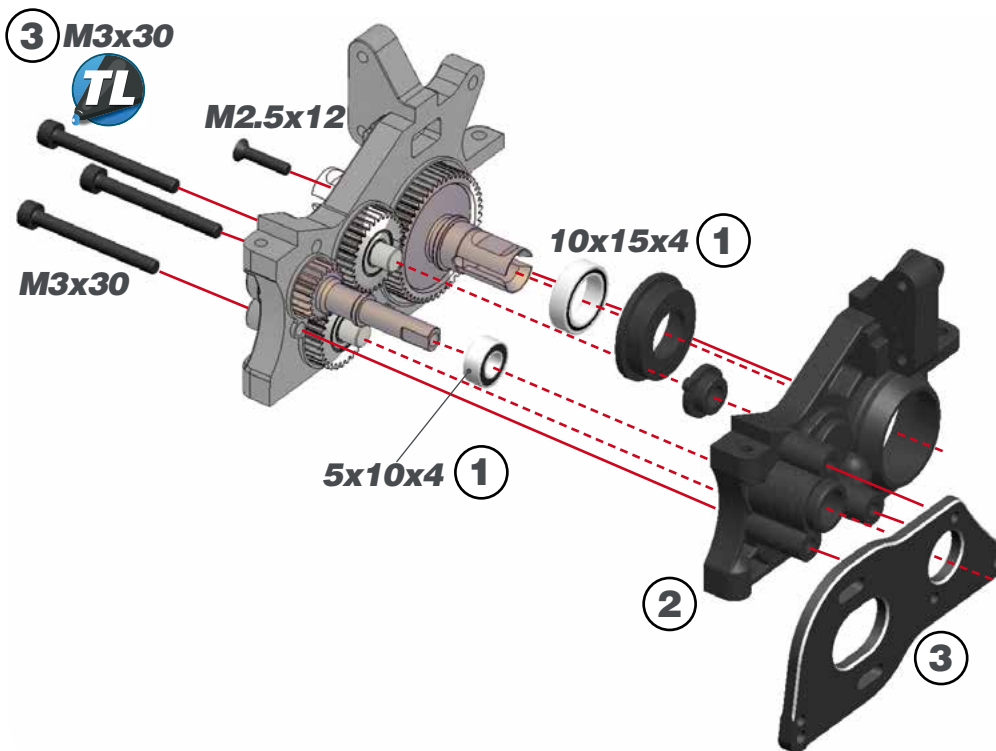

# STEP 26

## BAG 5 A+B

Depending on the choice of transmission (3-gear standing or 3-gear laydown) choose the correct sub-bag for assembly.

### 3 GEARS LAYDOWN TRANSMISSION *DEFAULT*

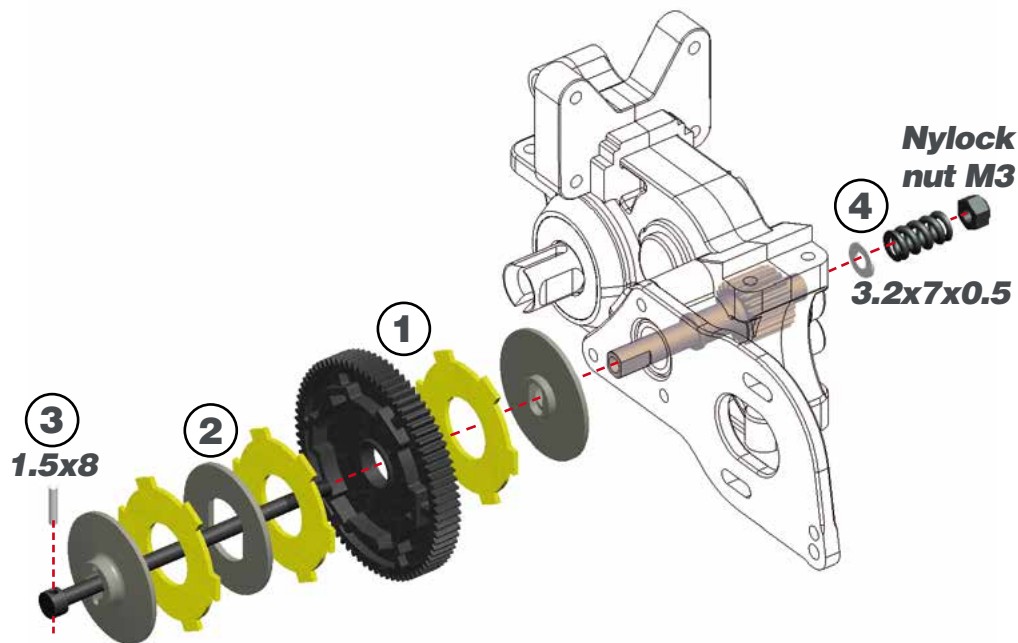
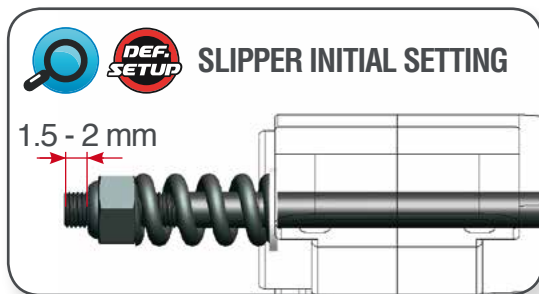

### 4 GEARS LAYDOWN TRANSMISSION *OPTIONAL (NOT INCLUDED)*

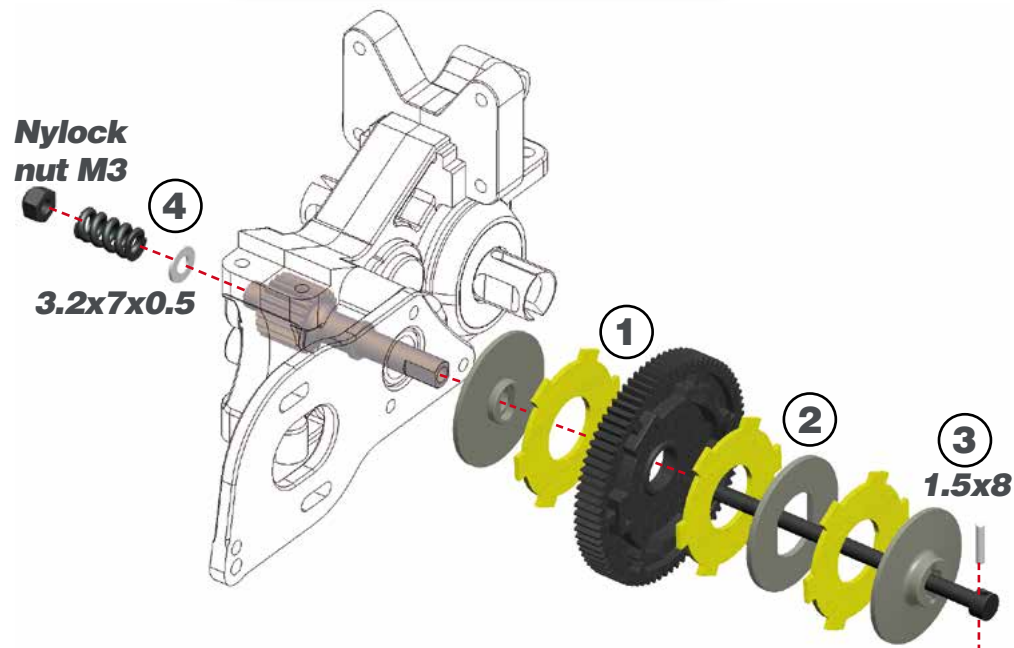
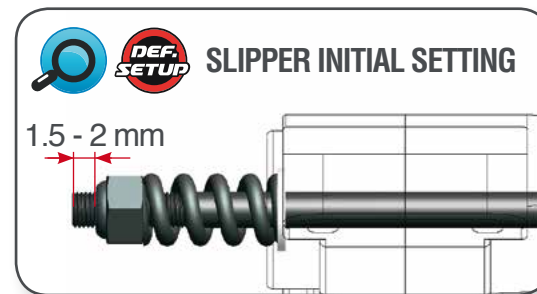

# STEP 27

## 3 GEARS LAYDOWN TRANSMISSION **DEFAULT**

**!** **NI** Pinion is NOT INCLUDED in the kit. See Serpent pinion list in the ref-guide.

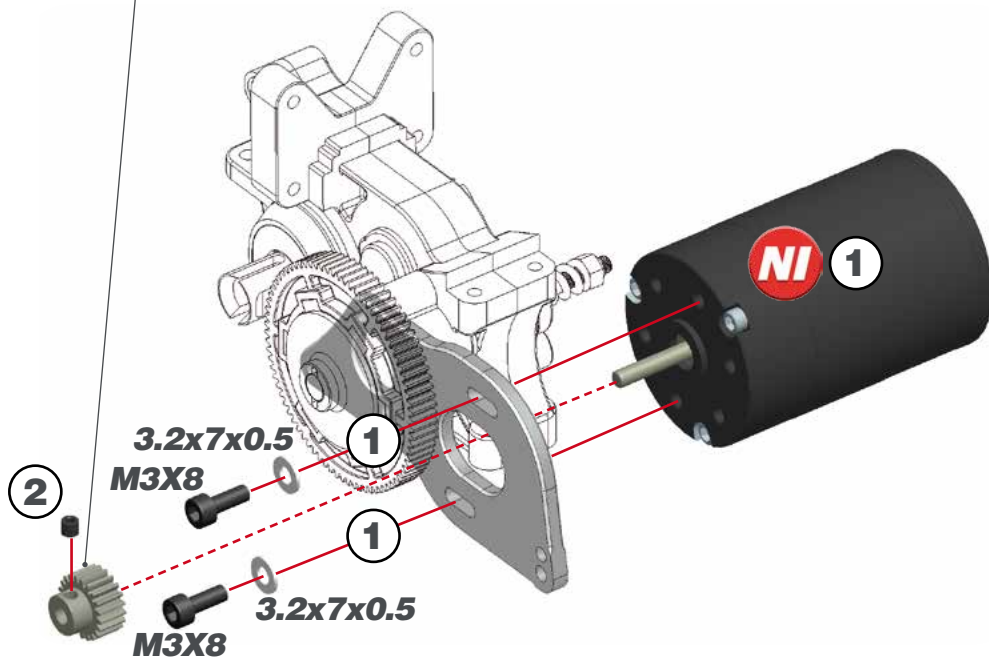

## 4 GEARS LAYDOWN TRANSMISSION **OPTIONAL (NOT INCLUDED)**

**!** **NI** Pinion is NOT INCLUDED in the kit. See Serpent pinion list in the ref-guide.

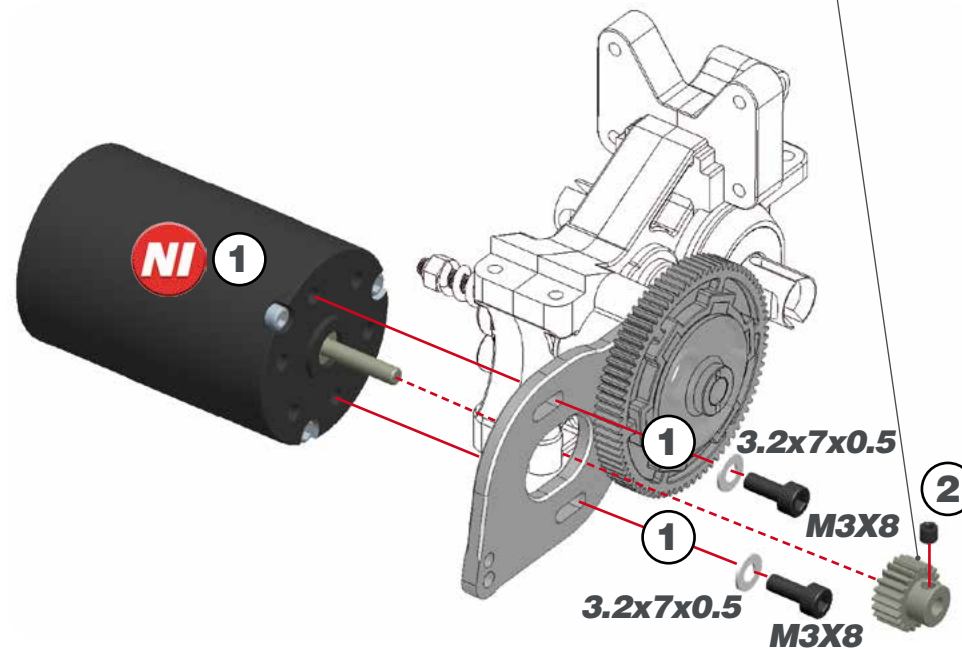

# STEP 28

**3 GEARS LAYDOWN TRANSMISSION** *DEFAULT*

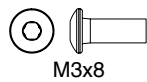
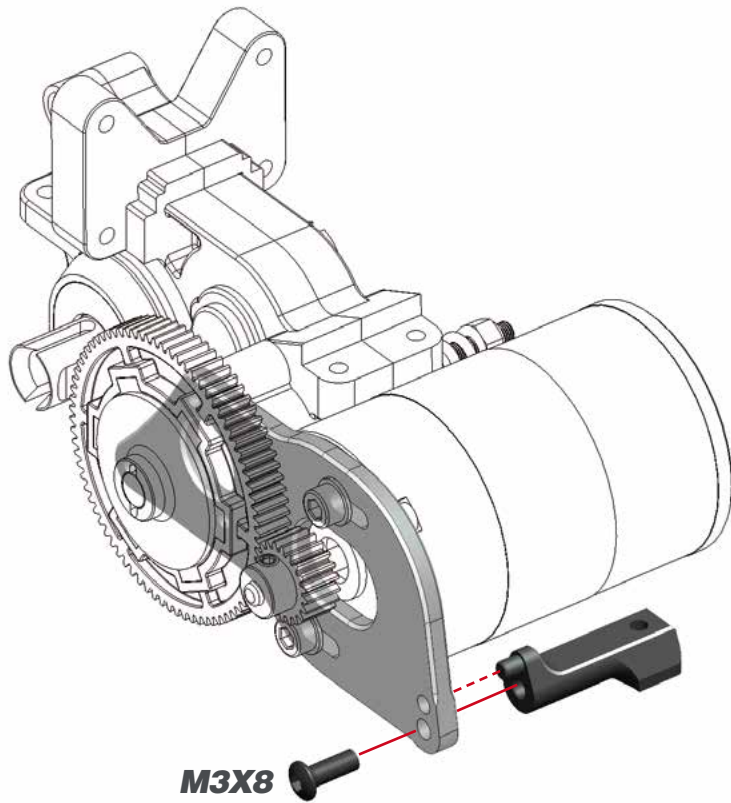

**4 GEARS LAYDOWN TRANSMISSION** *OPTIONAL (NOT INCLUDED)*

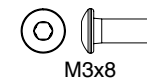
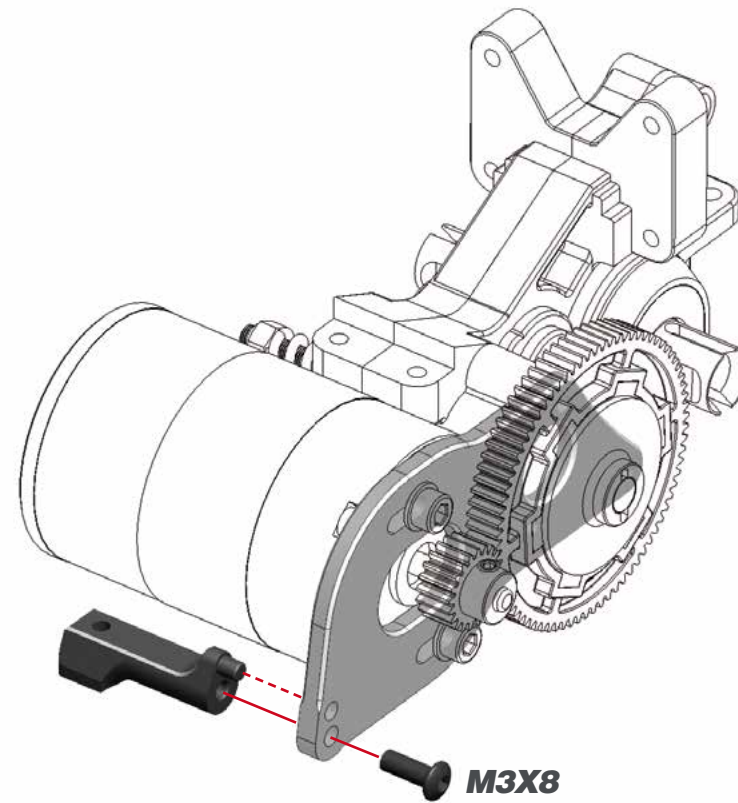

STEP 29

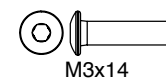
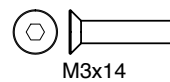
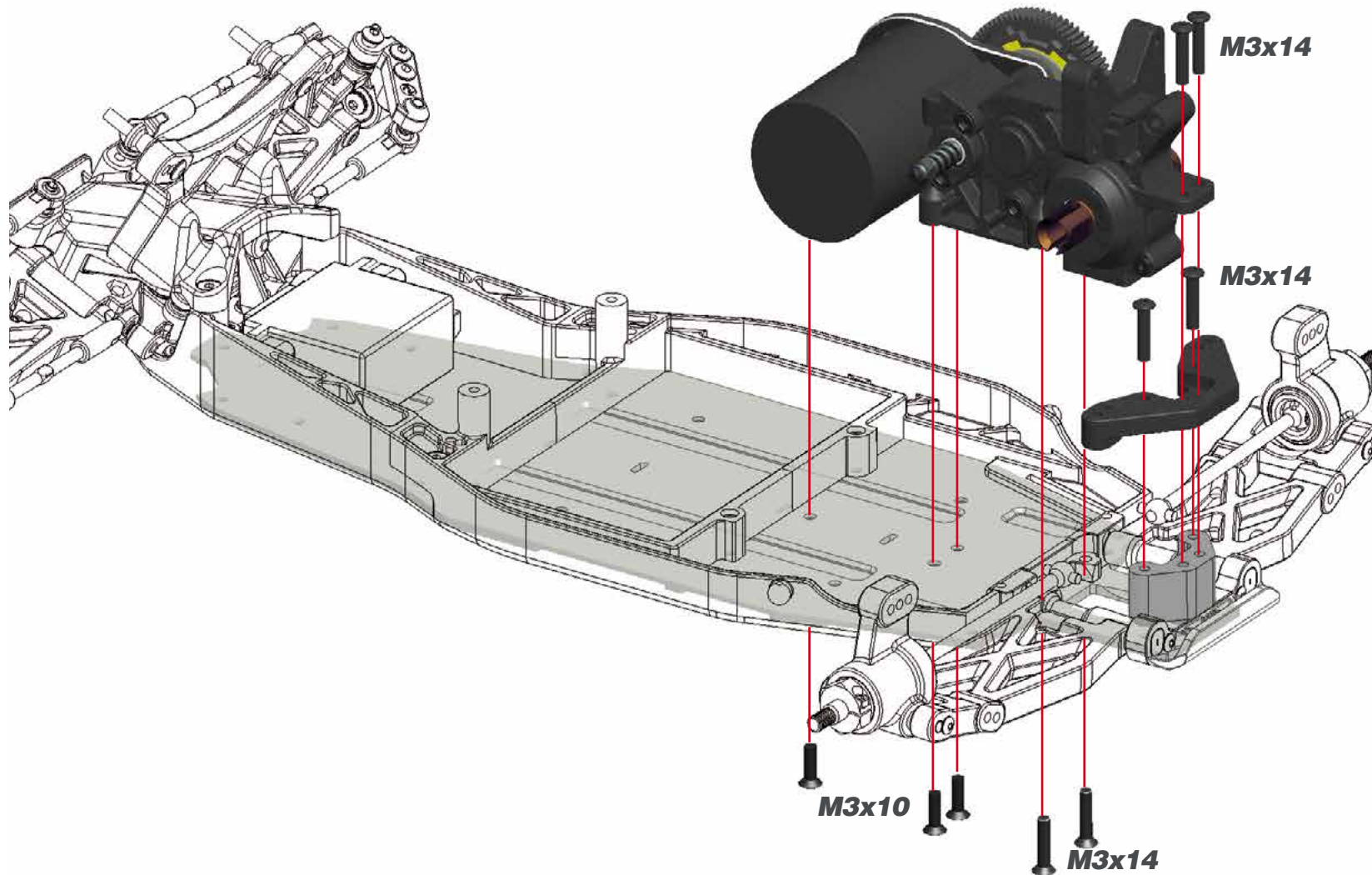

# STEP 30

## BAG 6 A+C

Depending on the choice of transmission (3-gear standing or 3-gear laydown) choose the correct sub-bag for assembly.

### 30.1



**REAR CAMBERLINK LENGTH**

DEF. SETUP

L=R

27.9 mm

### 30.2

**BALLSTUD LENGTH**

SHORT LONG

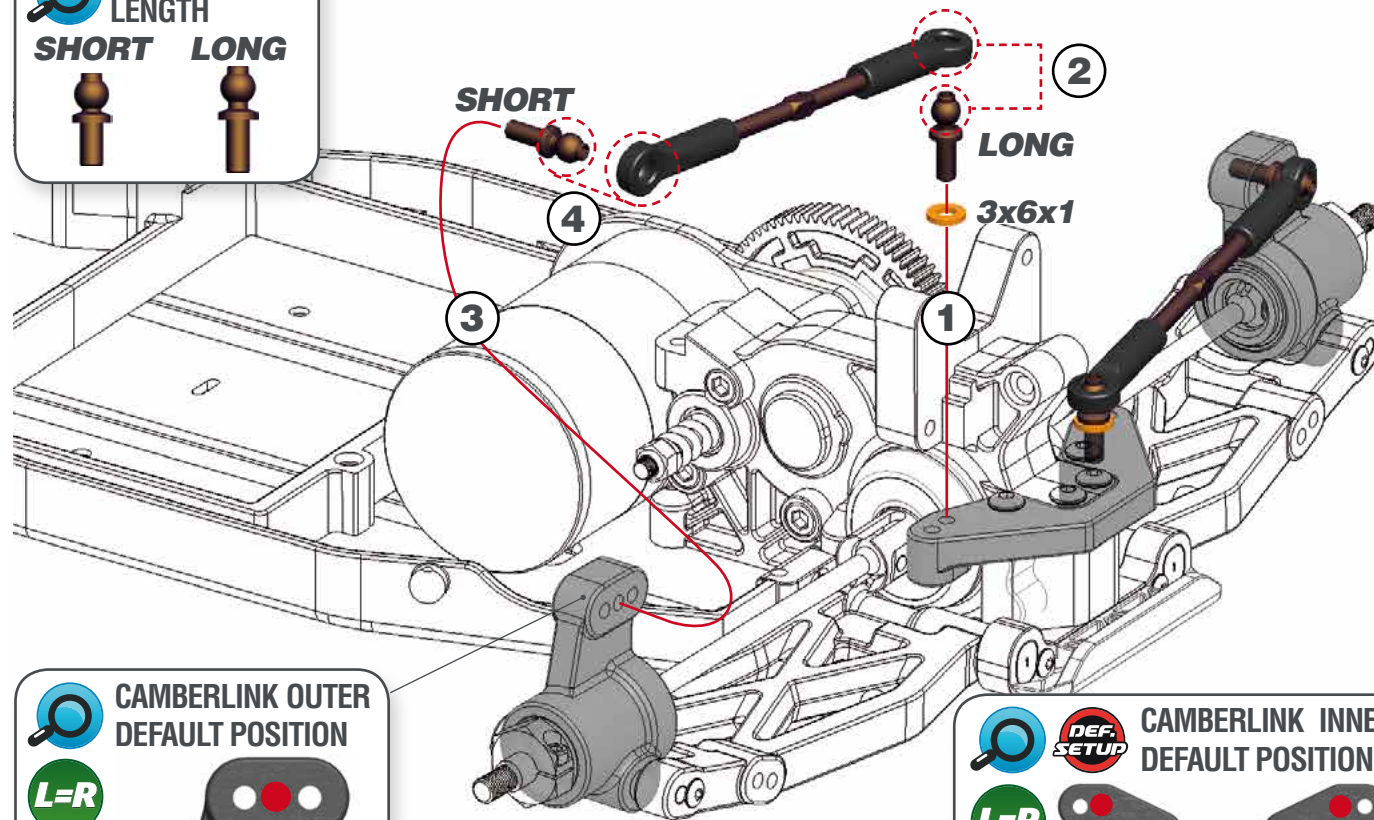

**CAMBERLINK OUTER DEFAULT POSITION**

L=R

DEF. SETUP

**CAMBERLINK INNER DEFAULT POSITION**

DEF. SETUP

L=R

3x6x1



# STEP 31

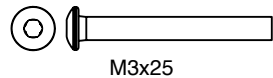
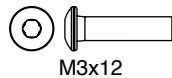
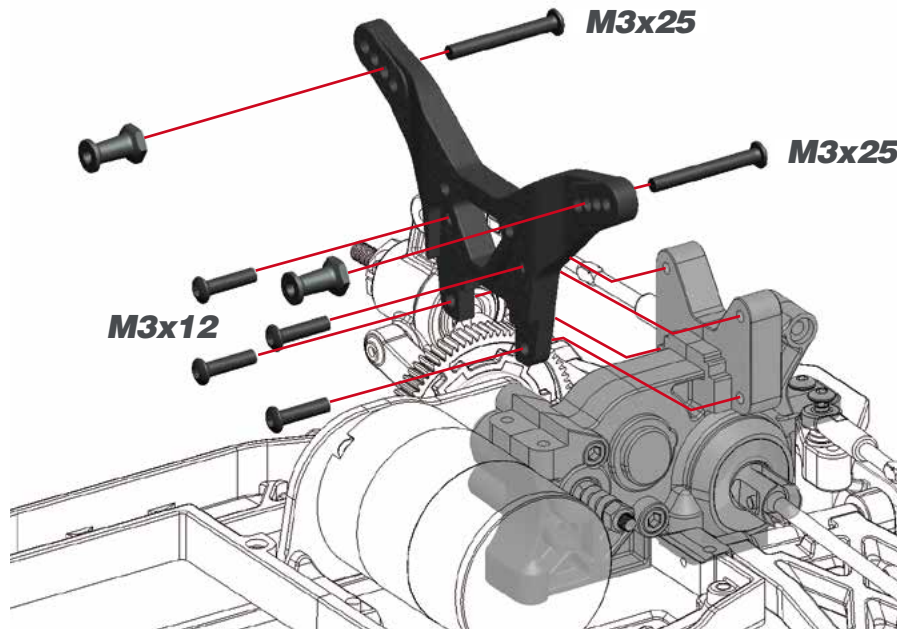

# STEP 32

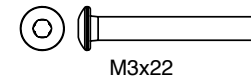
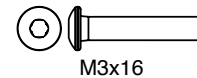
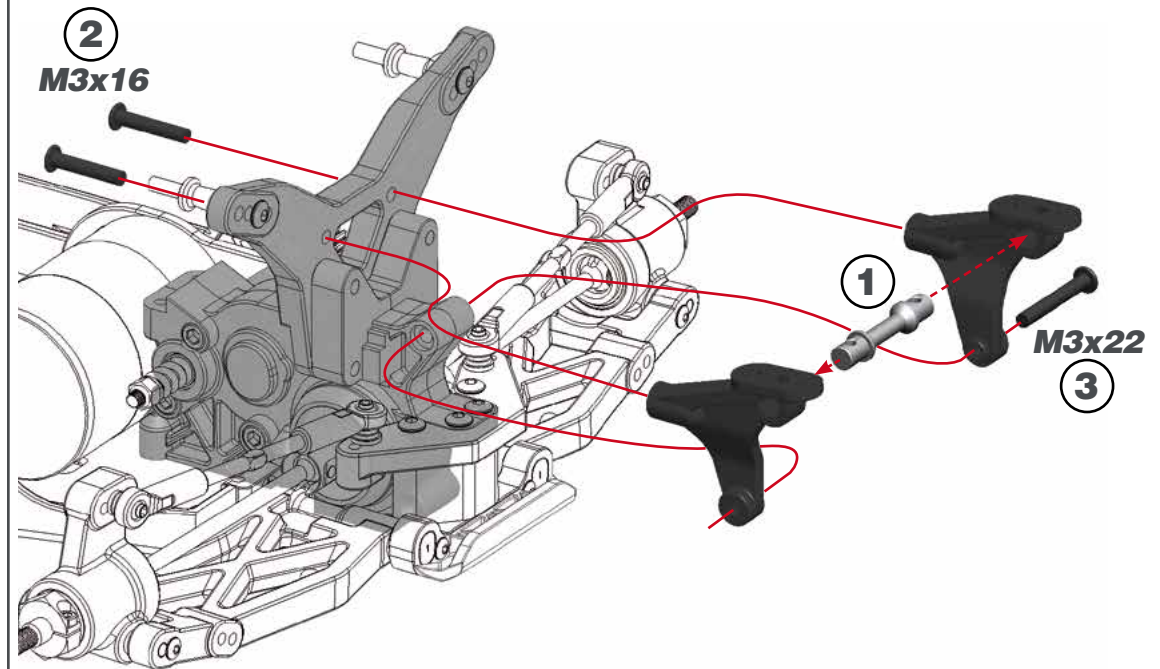

**STEP 33**

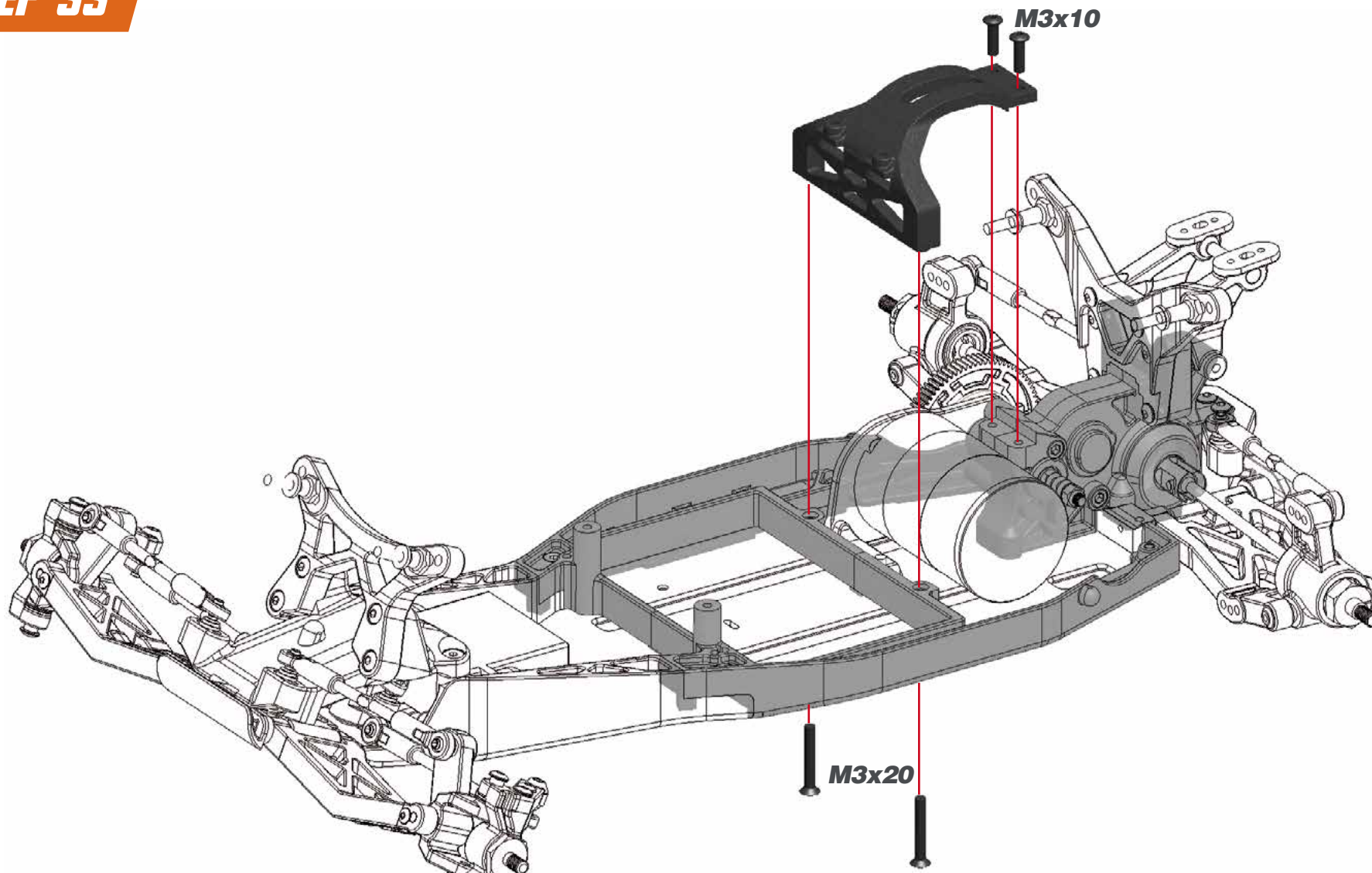

M3x20



M3x10

## STEP 34 BAG 7 FR SHOCKS / BAG 8 RR SHOCKS

## STEP 35

### 34.1

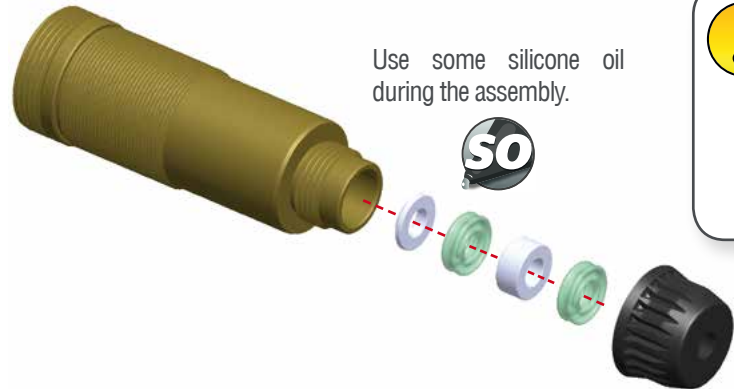

Use some silicone oil during the assembly.

SO



Note the correct orientation of the shock spacers.

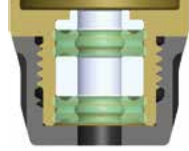

### 34.2

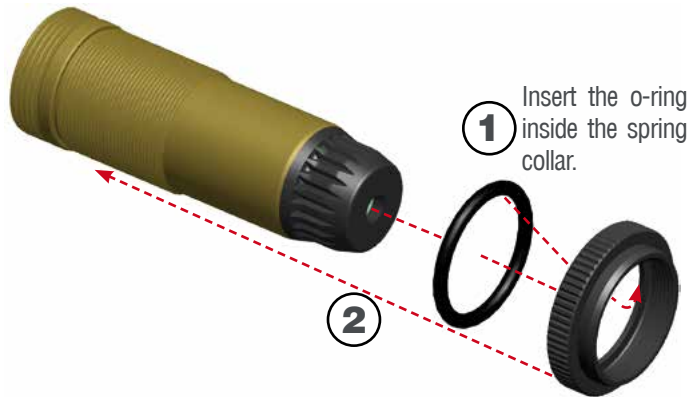

1 Insert the o-ring inside the spring collar.



Note the correct position of the o-ring.



### 35.1

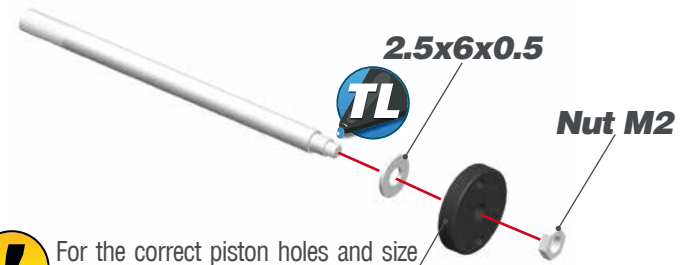

2.5x6x0.5

TL

Nut M2



For the correct piston holes and size please check the default setupsheet.

### 35.2

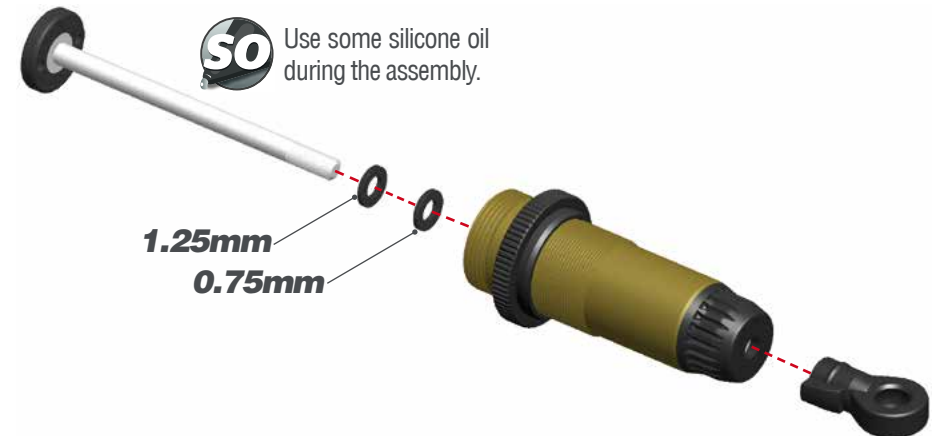

SO

Use some silicone oil during the assembly.

1.25mm

0.75mm

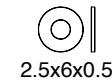

2.5x6x0.5



Nut M2

# STEP 36

## 36.1

1- Fill up with silicone oil fully using the silicone oil supplied in the kit. For the correct cst value please check the default setupsheet.

2- Extend the shockrod fully

3- Move the shockrod slowly up and down to let ALL air bubbles escape.

4- Apply the gasket and cap and close fully.



## 36.2

1-Bleed: push the shock-rod all the way in slowly, to allow excessive oil to escape.

2- With shockrod fully in, mount the o-ring and screw.

**M2.3x4**



**SHOCKS LENGTH:** Measure the shock length fully extended.

**FRONT**      **REAR**

20.5 mm      28.5 mm

# STEP 37

Assemble the spring and spring-cup (align correctly) to complete the shock.

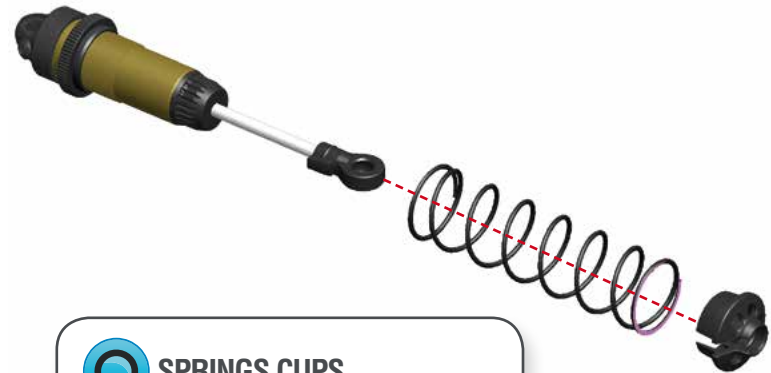

**SPRINGS CUPS**

**FRONT HIGH**      **REAR LOW**

# STEP 38



Do not overtighten or smash bushing with the nut and note orientation of the lower shock pivot ball.

**M3 Plastic Nut Flanged**

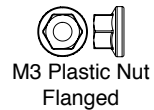
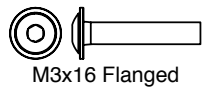
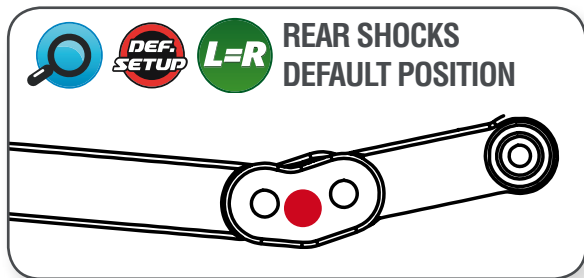
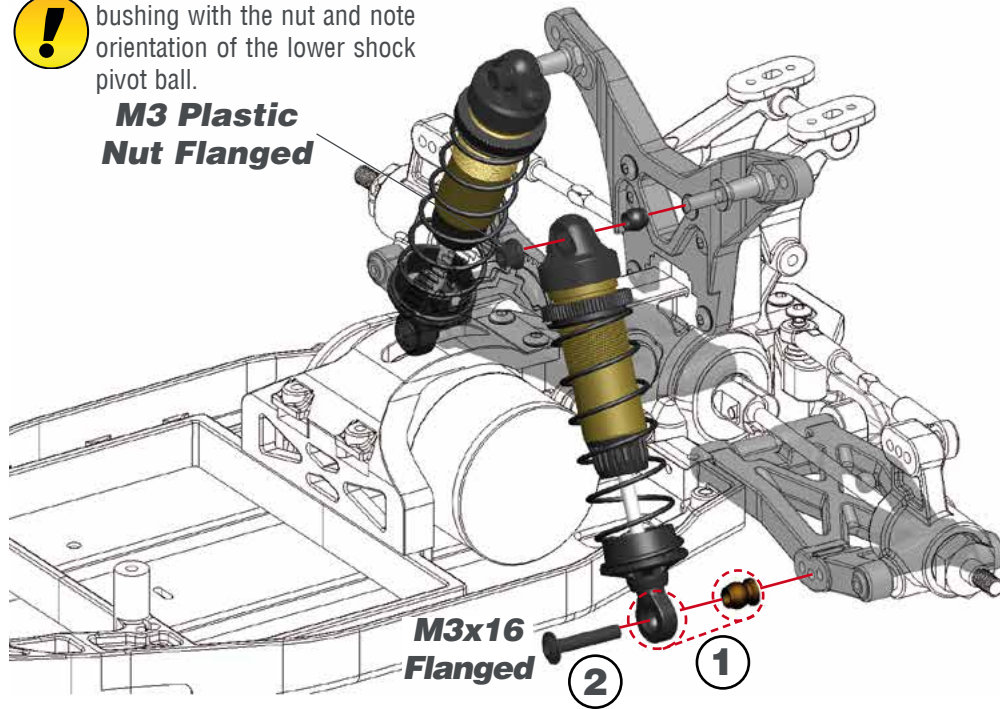

# STEP 39



Do not overtighten or smash bushing with the nut and note orientation of the lower shock pivot ball.

**M3 Plastic Nut Flanged**

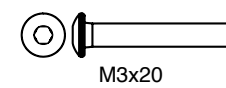
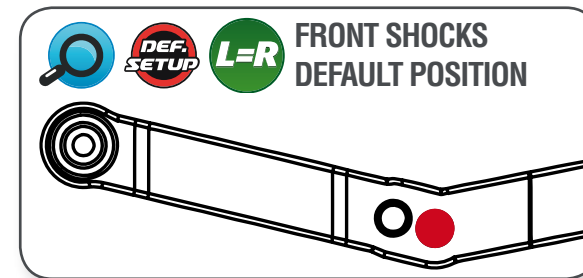
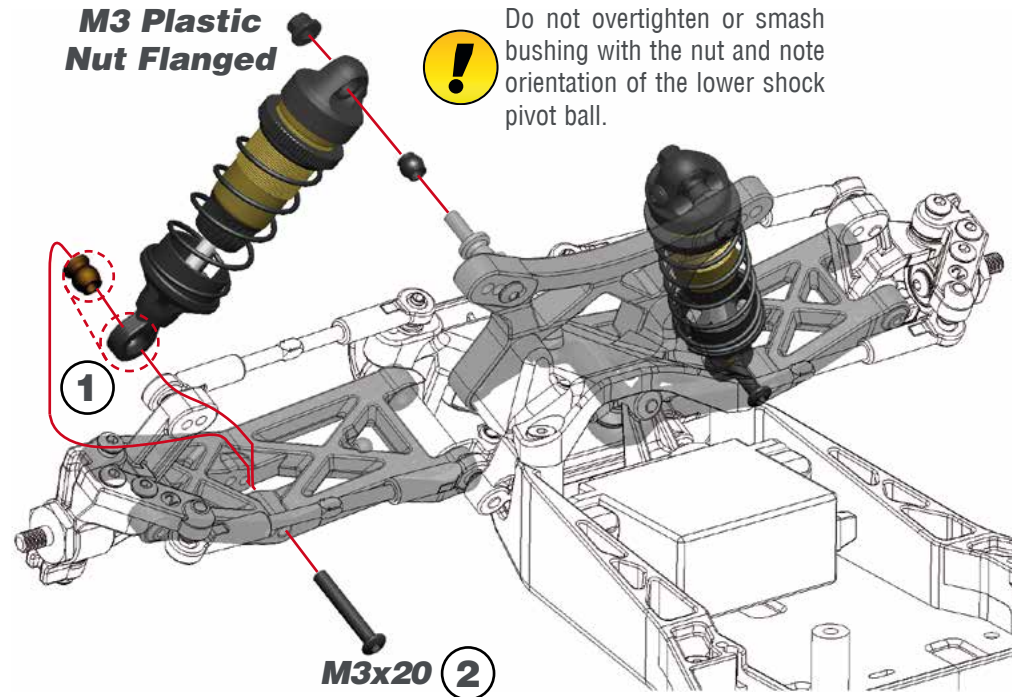

## STEP 40

### BAG 9 A+C

Depending on the choice of transmission (3-gear standing or 3-gear laydown) choose the correct sub-bag for assembly.

**!** Use double sided tape to mount the ESC and RX to the chassis.

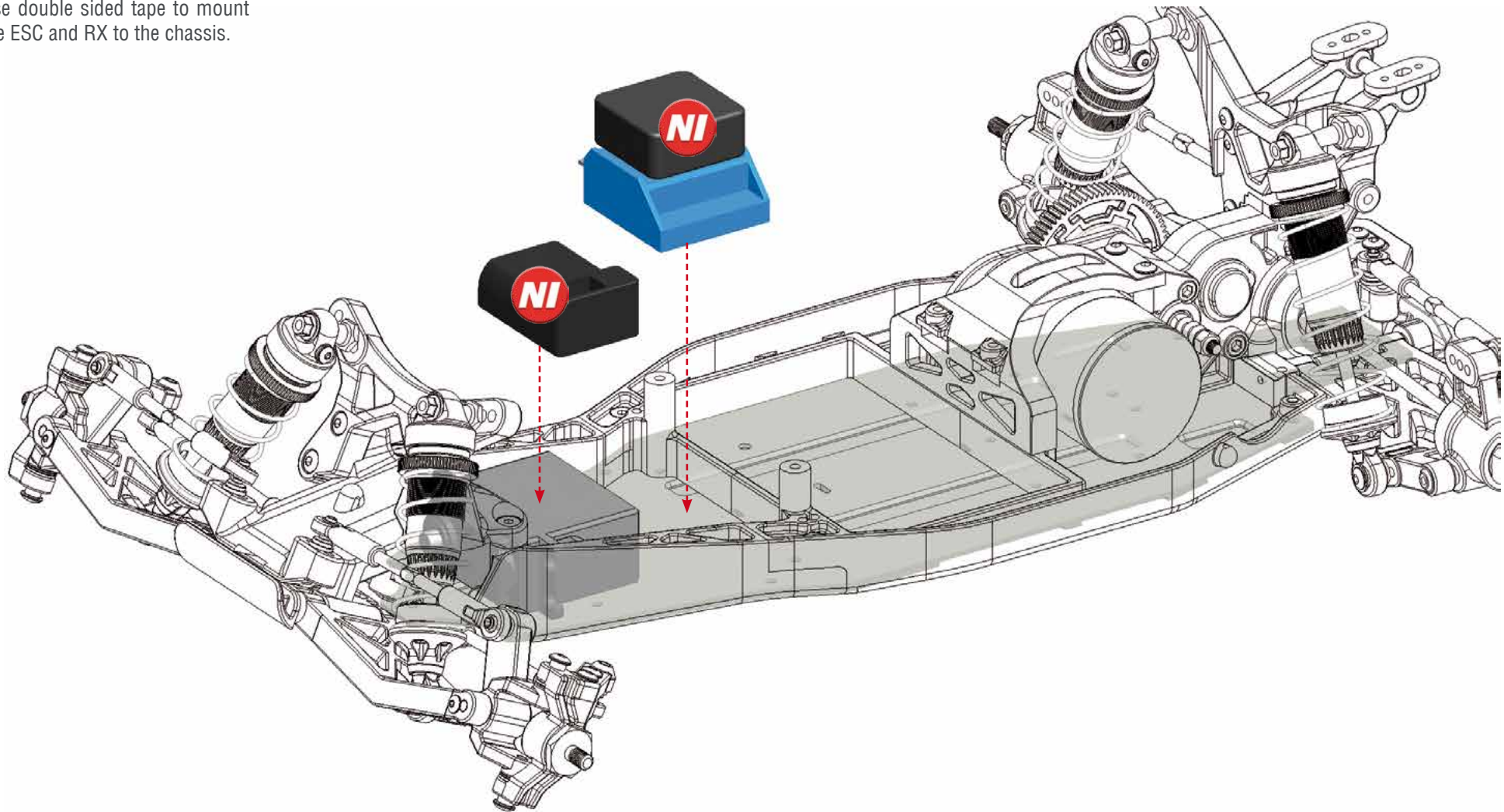

STEP 41

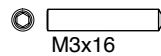
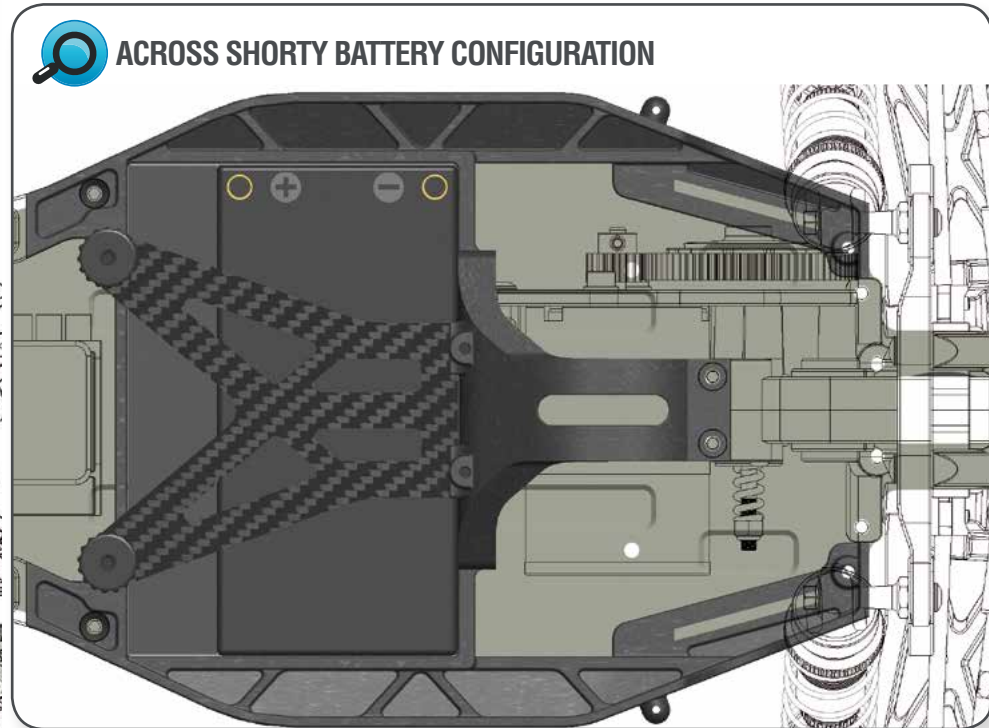
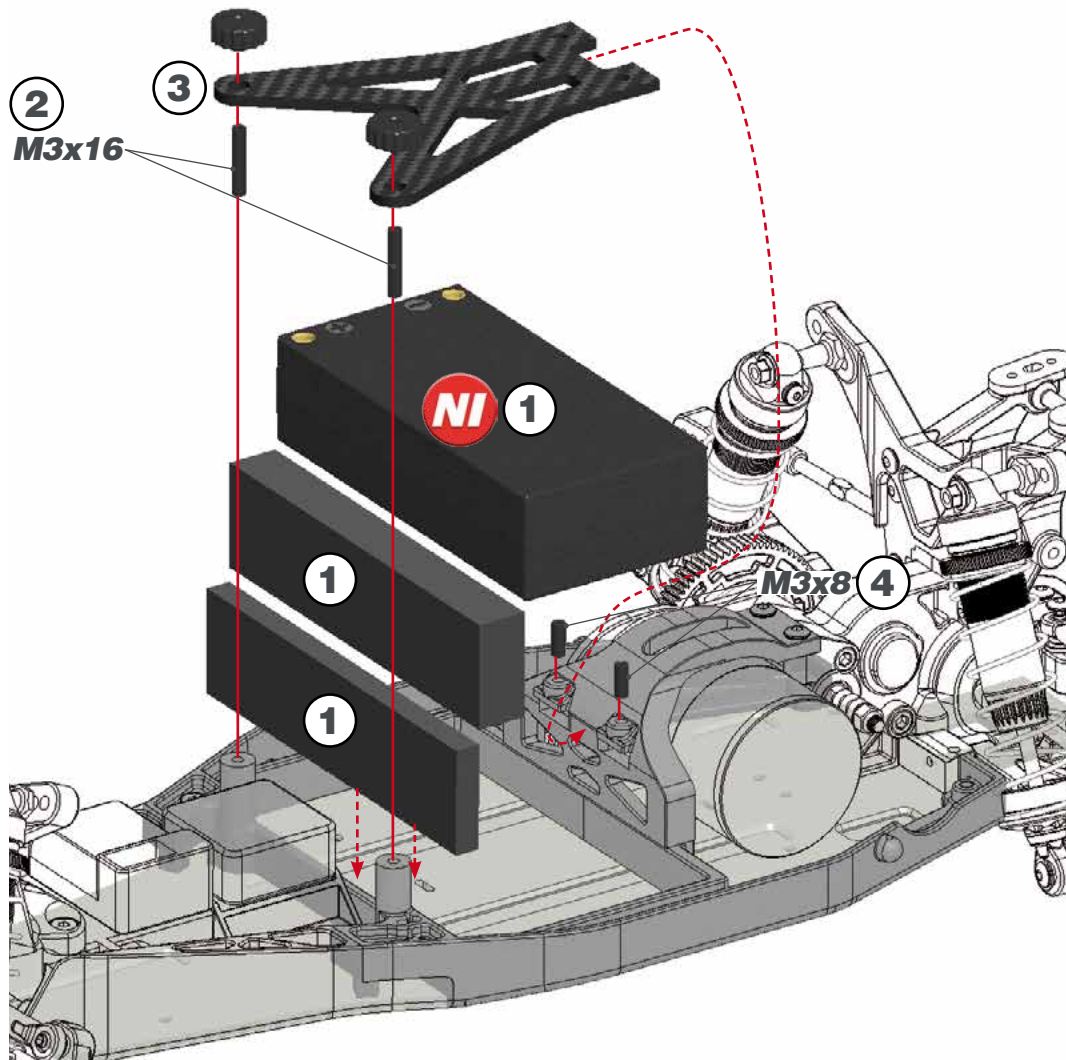

**STEP 42**

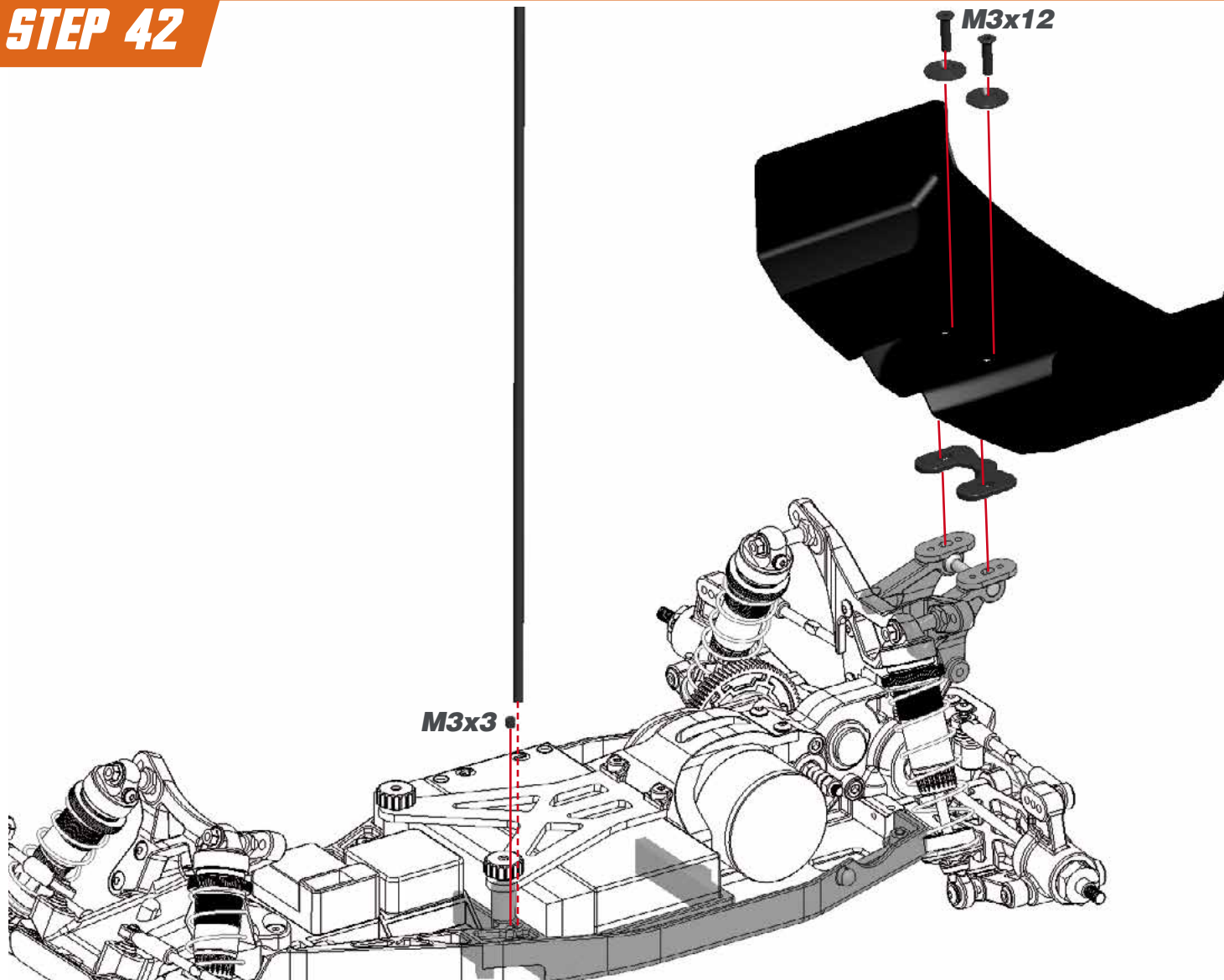

**ANGLED WING SPACERS CHART**

0°		
2°		<b>DEF. SETUP</b>
4°		
6°		
8°		

**FRONT** ↔ **REAR**

M3x3

M3x12



## STEP 43

**!** 1- Cut the body along the cutting line with special scissors (not included). Make holes for the bodypost and antenna as needed with a body reamer (not included).

2- Before painting the body, apply the precut masking sheet elements to the inside of the body. Follow the cleaning & painting instructions supplied by the polycarbonate paint supplier you choose.

3- Apply the Serpent and Spyder logo-decals on the body and wing.

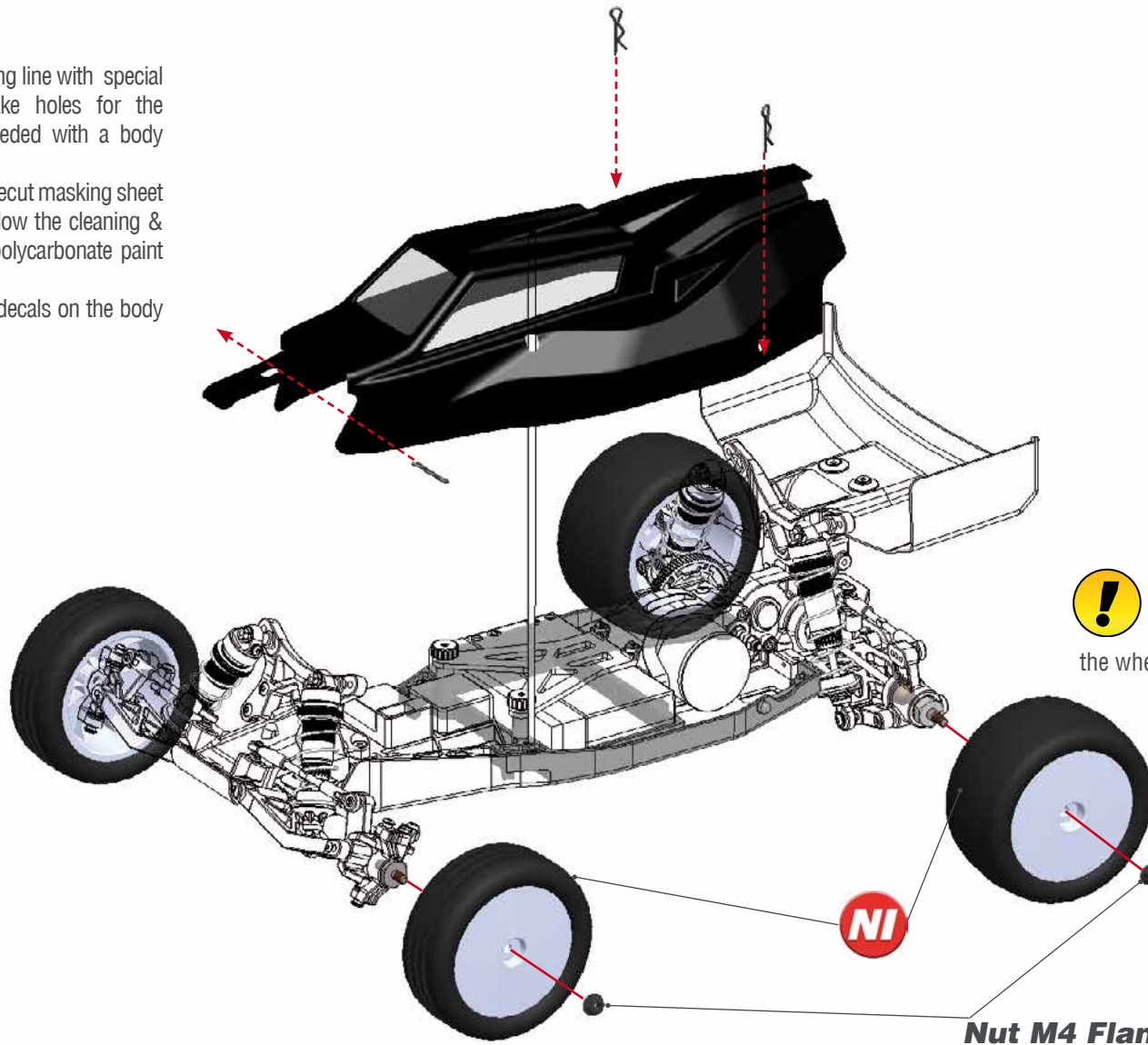

**!** 1- Rims included in the kit.  
2- Rubber tyres not included in the kit.  
3- Be sure to glue your rubber tyres to the wheels using Cyanoacrylate glue.

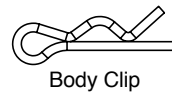

## INDEX

<b><i>DIFFERENTIAL EXPLODED VIEW</i></b>	<b><i>31</i></b>
<b><i>CENTRAL AND STEERING EXPLODED VIEW</i></b>	<b><i>32</i></b>
<b><i>FRONT EXPLODED VIEW</i></b>	<b><i>33</i></b>
<b><i>TRANSMISSION EXPLODED VIEW</i></b>	<b><i>34</i></b>
<b><i>REAR EXPLODED VIEW</i></b>	<b><i>35</i></b>
<b><i>SHOCKS EXPLODED VIEW</i></b>	<b><i>36</i></b>
<b><i>FINAL EXPLODED VIEW</i></b>	<b><i>37</i></b>
<b><i>TEAM SERPENT NETWORK</i></b>	<b><i>38</i></b>

# DIFFERENTIAL EXPLODED VIEW

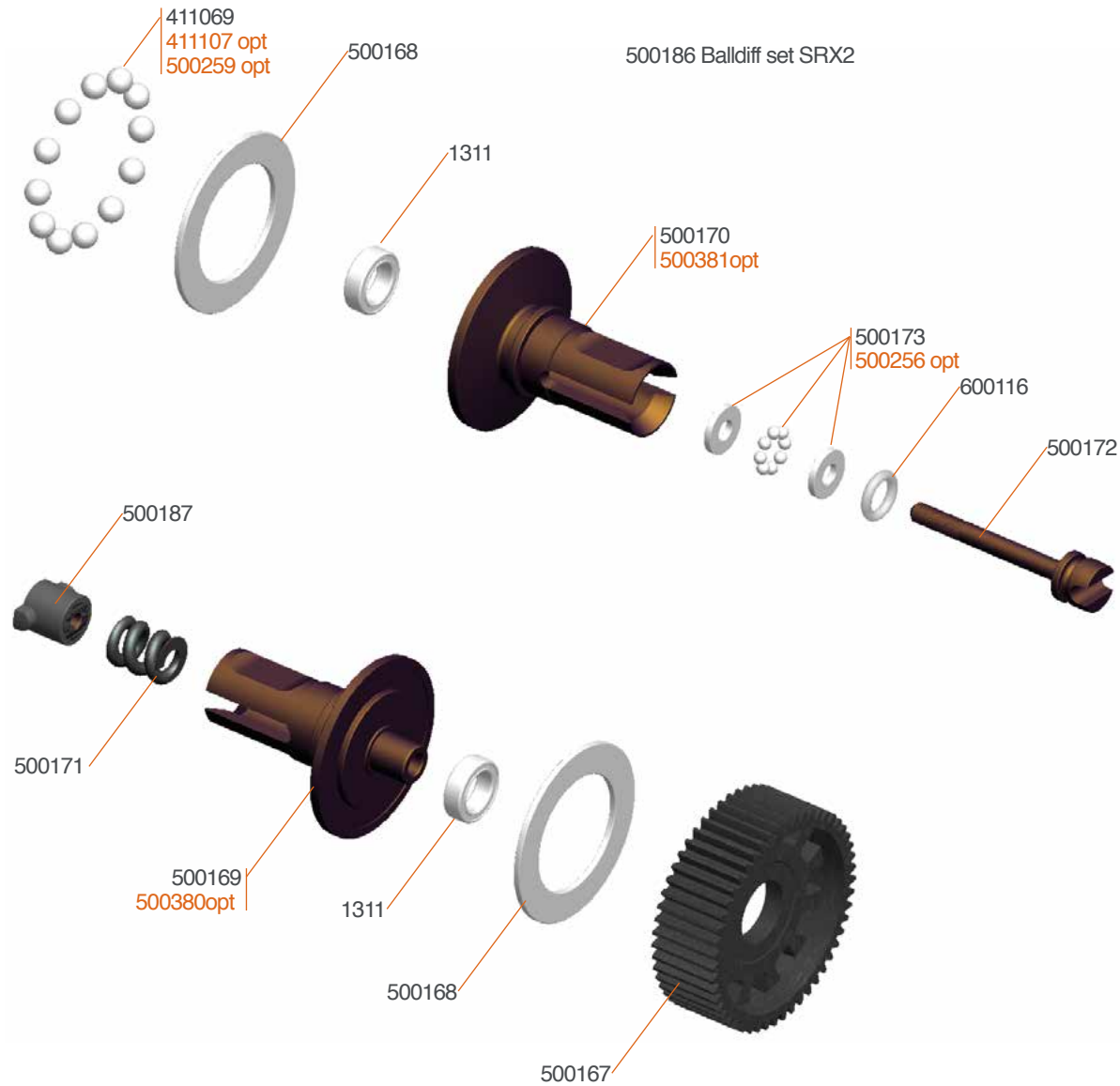

411107 Diff balls. 1/8 ceramic (12)  
 500259 Differential balls carbide 1/8  
 500256 Thrustbearing carbide balldiff SRX2  
 500376 Slide drive set SRX

500380 Balldiff outdrive slide drive male  
 500381 Balldiff outdrive slide drive female  
 500192 Geardiff set SRX2

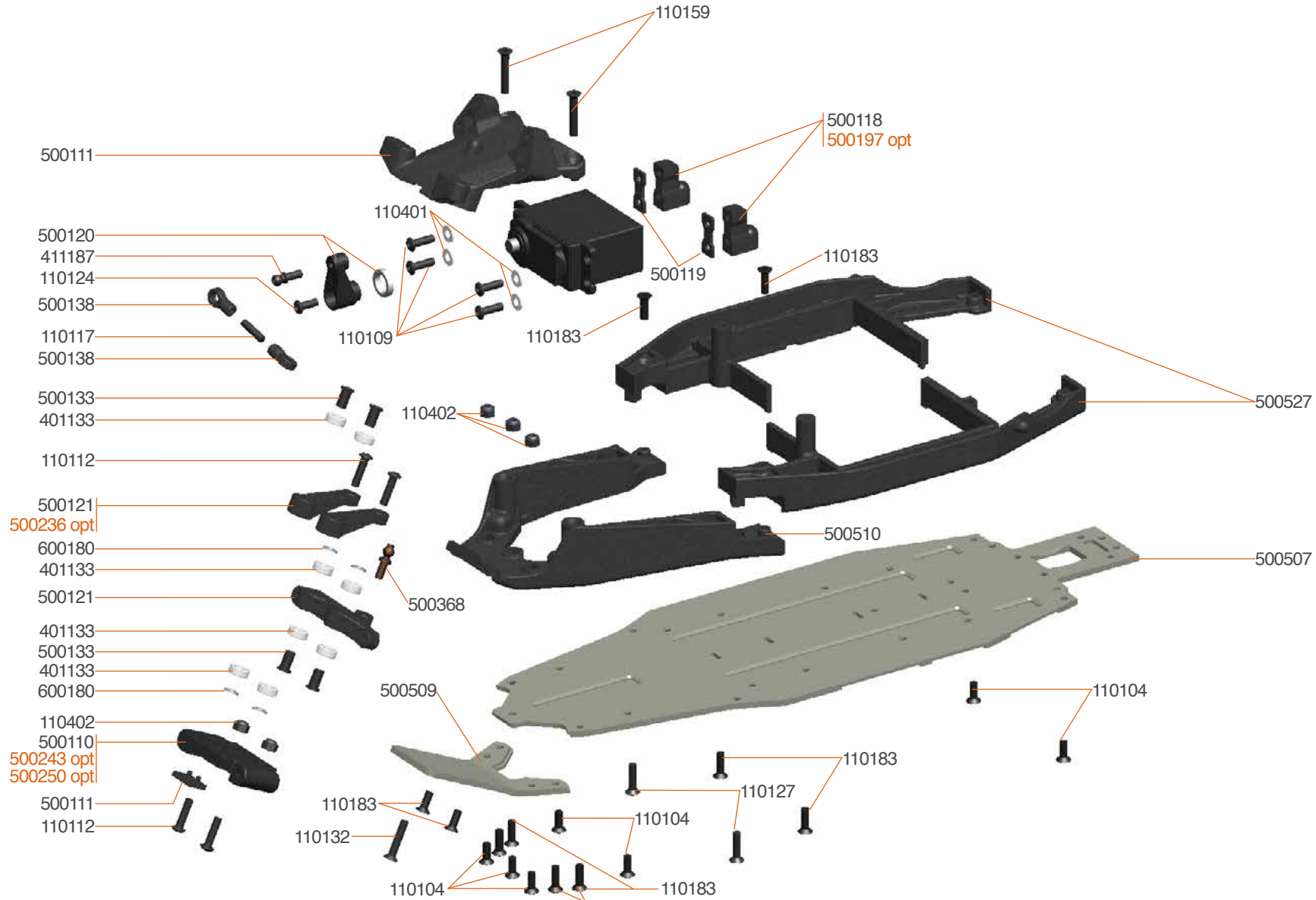

- 500197 Servomount alu (2) SRX2
- 500236 Steeringrack alu (3) SRX2
- 500243 Front bulkhead alu SRX2
- 500250 Front bulkhead brass SRX2

# FRONT II EXPLODED VIEW

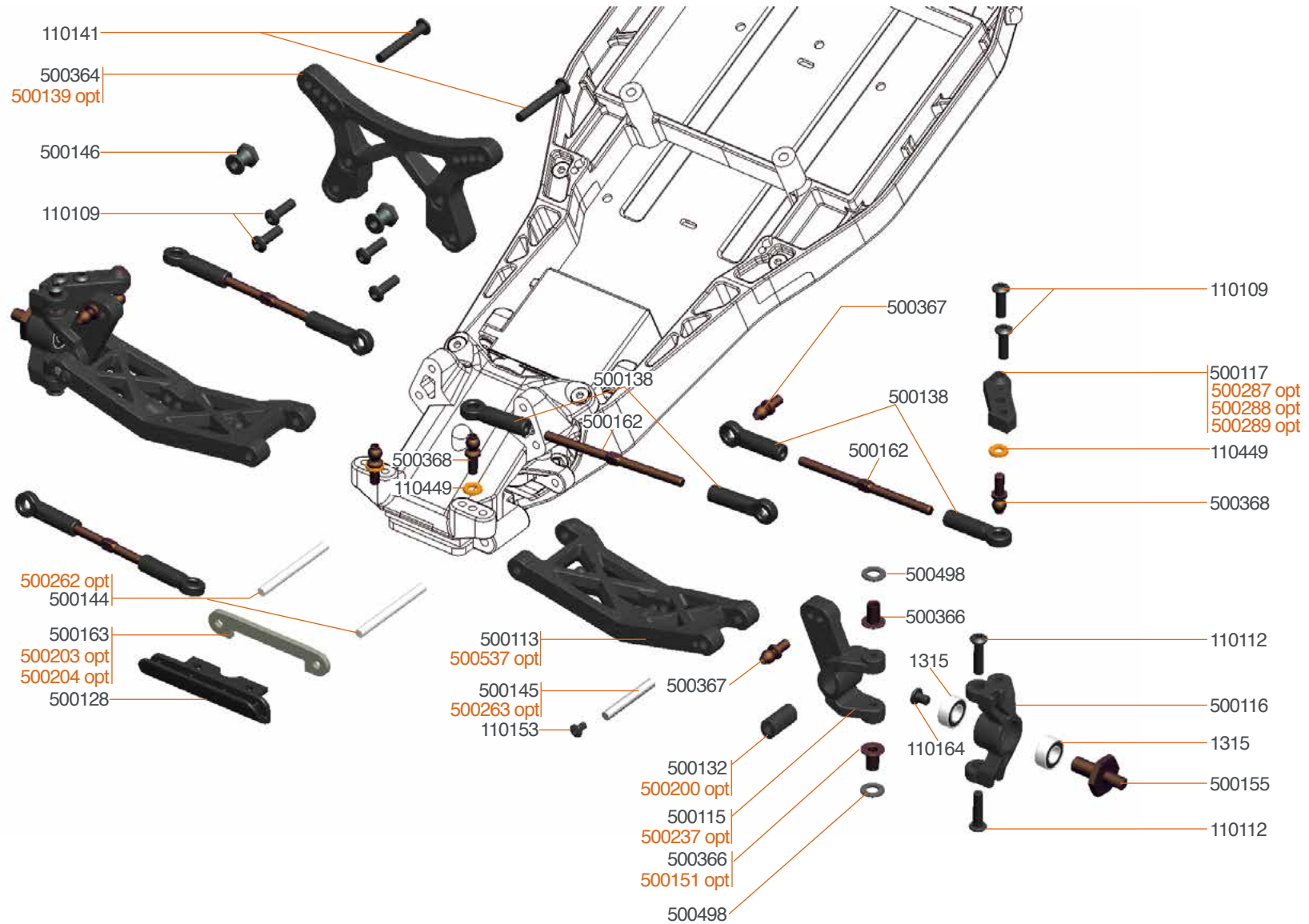

- 500139 Shocktower carbon fr SRX2
- 500151 Casterblock bushing (4) SRX2
- 500194 Antiroll bar set fr SRX2
- 500200 Front bulkhead inserts alu (6) SRX2
- 500203 Pivot pin brace 20 deg fr SRX2

- 500204 Pivot pin brace 30 deg fr SRX2
- 500237 C-hub L+R alu SRX2
- 500262 Pivot pin fr inner / rr outer TiN coated (2) SRX2
- 500263 Pivot pin fr outer TiN coated (2) SRX2
- 500287 Steering arm nr 1 brass L+R

- 500288 Steering arm nr 2 brass L+R
- 500289 Steering arm nr 3 brass L+R
- 500537 Wishbone fr L+R SRX2 hard



# 3 GEAR TRANSMISSION EXPLODED VIEW



500213 Spur gear 70T SRX2  
 500214 Spur gear 72T SRX2  
 500215 Spur gear 76T SRX2  
 500217 Spur gear 80T SRX2

500218 Spur gear 82T SRX2  
 500219 Spur gear 84T SRX2  
 500220 Spur gear 86T SRX2  
 500221 Spur gear 88T SRX2

500242 Slipper plates vented alu (3) SRX2  
 500352 Top-shaft set 21T stock SRX2  
 500353 Top-shaft 21T stock SRX2

# 4 GEAR TRANSMISSION EXPLODED VIEW (OPTIONAL)

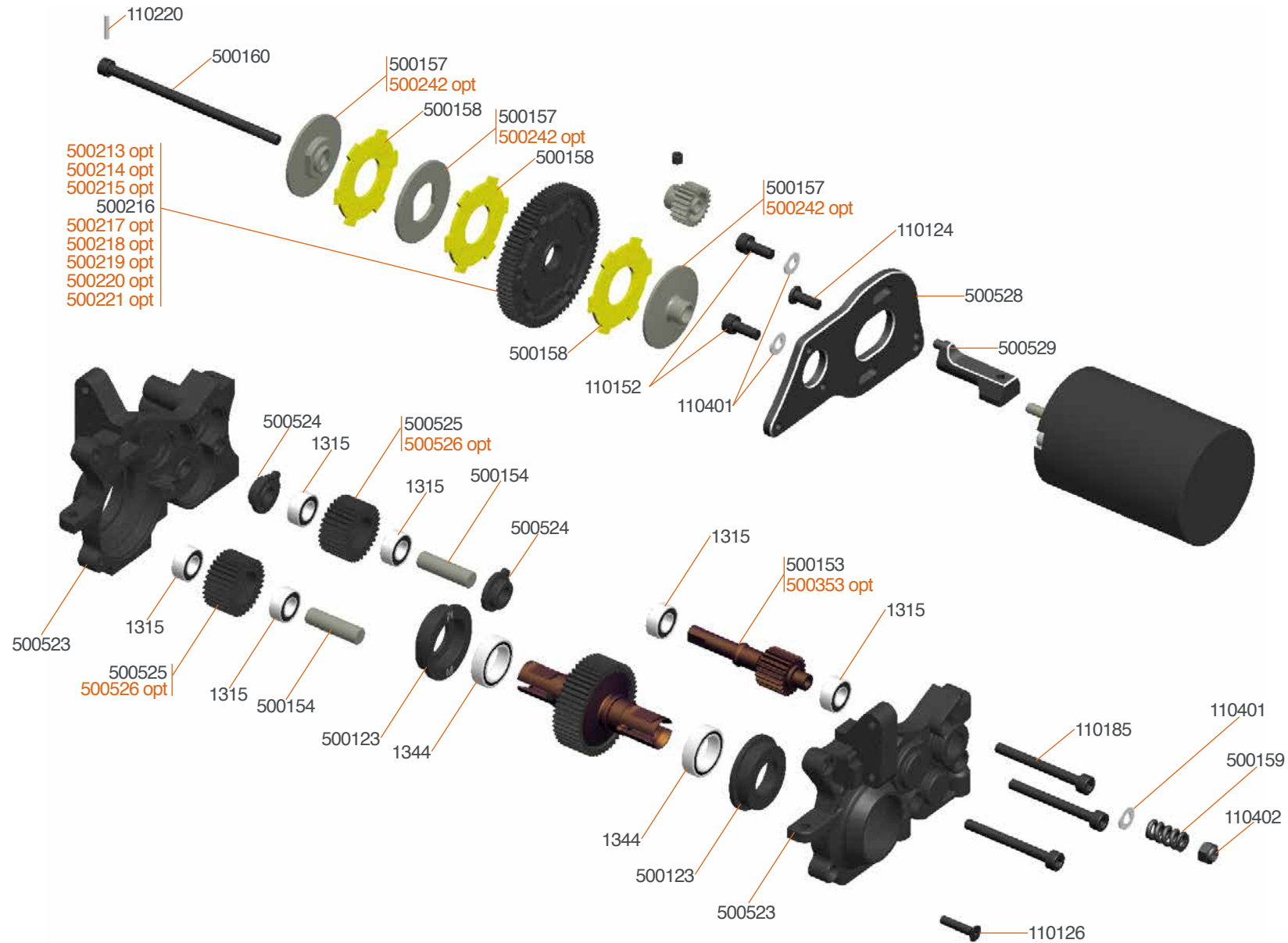

500213 Spur gear 70T SRX2  
 500214 Spur gear 72T SRX2  
 500215 Spur gear 76T SRX2  
 500217 Spur gear 80T SRX2

500218 Spur gear 82T SRX2  
 500219 Spur gear 84T SRX2  
 500220 Spur gear 86T SRX2  
 500221 Spur gear 88T SRX2

500242 Slipper plates vented alu (3) SRX2  
 500260 Idler gear 27T alu SRX2  
 500344 Idler gear 27T SRX2 steel  
 500352 Top-shaft set 21T stock SRX2

500353 Top-shaft 21T stock SRX2

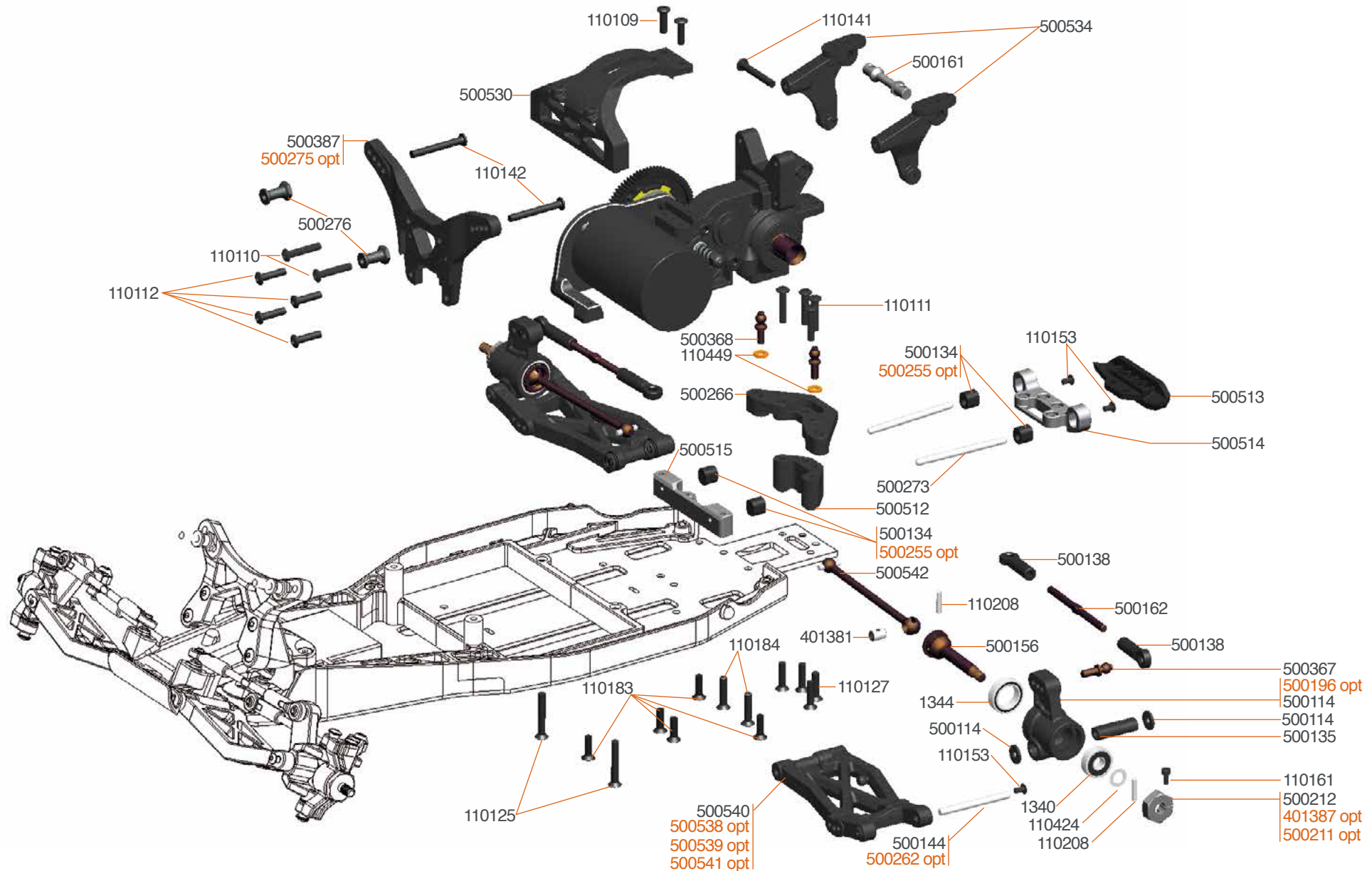

- 500196 Upright L+R alu SRX2
- 500211 Wheelhexagon +0.75mm offset (2)
- 401387 Wheelhexagon 1mm offset (2)
- 500255 Suspension insert rr 3deg alu (2) SRX2

- 500275 Shocktower carbon rr SRX2 MM
- 500262 Pivot pin fr inner / rr outer TiN coated (2) SRX2
- 500281 Antiroll bar set rr SRX2 MM
- 500538 Wishbone rr L+R SRX2 MM V2

- 500539 Wishbone rr L+R SRX2 MM V2 hard
- 500541 Wishbone rr L+R long SRX2 MM hard

- 500367
- 500196 opt
- 500114
- 500114
- 500135
- 110161
- 500212
- 401387 opt
- 500211 opt



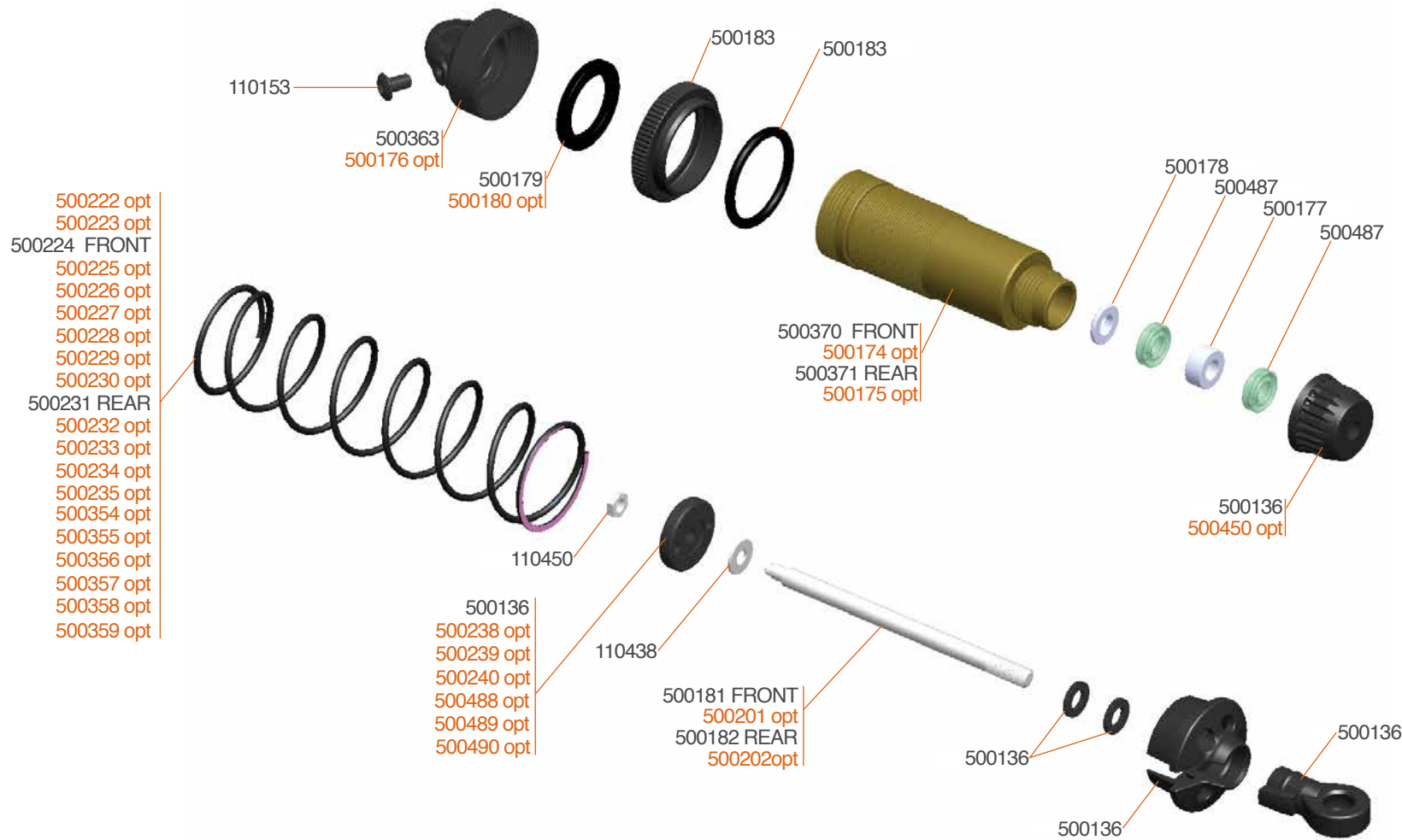

- 500450 Shock bottom cap alu (4) SRX
- 500238 Shock piston conical 2 holes (4) SRX2
- 500239 Shock piston conical 3 holes (4) SRX2
- 500240 Shock piston conical 4 holes (4) SRX2
- 500488 Shock piston square machined 2-hole 1.3 (4)
- 500489 Shock piston square machined 3-hole 1.2 (4)
- 500490 Shock piston square machined 4-hole 1.1 (4)
- 500201 Shock shaft fr TiN coated (2) SRX2
- 500202 Shock shaft rr TiN coated (2) SRX2
- 500180 Shock membrane (4) SRX2
- 500174 Shock body fr (2) SRX2

- 500175 Shock body rr (2) SRX2
- 500176 Shock top (2) SRX2
- 500222 Shock spring silver 2,5lbs fr (2) SRX2
- 500223 Shock spring black 2,65 fr (2) SRX2
- 500224 Shock spring orange 2,87lbs fr (2) SRX2
- 500225 Shock spring red 3,0lbs fr (2) SRX2
- 500226 Shock spring pink 3,15lbs fr (2) SRX2
- 500227 Shock spring blue 3,4lbs fr (2) SRX2
- 500228 Shock spring purple 3,5lbs fr (2) SRX2
- 500229 Shock spring green 3,7lbs fr (2) SRX2
- 500230 Shock spring orange 2,0lbs rr (2) SRX2

- 500231 Shock spring red 2,1lbs rr (2) SRX2
- 500232 Shock spring pink 2,2lbs rr (2) SRX3
- 500233 Shock spring blue 2,3lbs rr (2) SRX2
- 500234 Shock spring purple 2,4lbs rr (2) SRX2
- 500235 Shock spring green 2,5lbs rr (2) SRX2
- 500354 Shock spring orange 1.8lbs rr astro (2) SRX2
- 500355 Shock spring red 1.9lbs rr astro (2) SRX2
- 500356 Shock spring pink 2.0lbs rr astro (2) SRX2
- 500357 Shock spring blue 2.1lbs rr astro (2) SRX2
- 500358 Shock spring purple 2.2lbs rr astro (2) SRX2
- 500359 Shock spring green 2.3lbs rr astro (2) SRX2



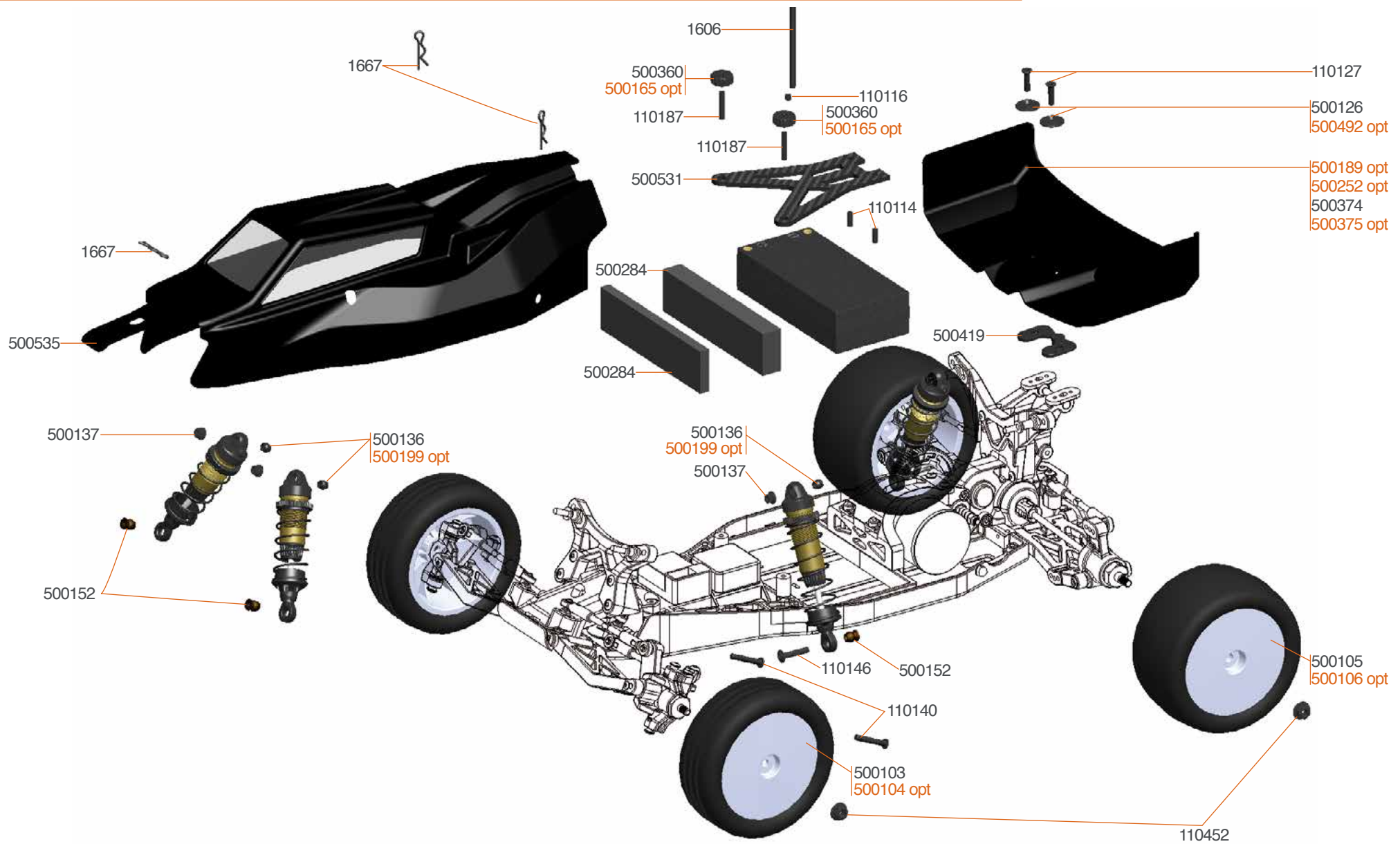

- 500492 Wing washer alu srx 1/10 (2)
- 500104 1/10 buggy rim fr 2wd yellow (2)
- 500106 1/10 buggy rim rr yellow (2)
- 500189 Rear wing 6.5

- 500199 Shock top bushing delrin (4) SRX2
- 500252 Rear wing 7.0
- 500375 Rear wing 7.0 (2)
- 500165 Battery plate nut (4) SRX2

# TEAM SERPENT NETWORK

## SPYDER SRX2 MH SPARE PARTS [www.serpent.com/500007/spares/](http://www.serpent.com/500007/spares/)



## SPYDER SRX2 MH OPTIONALS PARTS [www.serpent.com/500007/Optionals/](http://www.serpent.com/500007/Optionals/)



## SERPENT TOOLS [www.serpent.com/product/Tools/](http://www.serpent.com/product/Tools/)



## SERPENT MERCHANDISING [www.serpent.com/product/Merchandising/](http://www.serpent.com/product/Merchandising/)



## SERPENT WEBSITE AND BLOG

[www.serpent.com](http://www.serpent.com)  
[www.teamserpent.com](http://www.teamserpent.com)  
[www.dragon-rc.com](http://www.dragon-rc.com)

**SERPENT PROMO PAGES** <http://promo.serpent.com>

**SERPENT FACEBOOK GROUPS** <http://promo.serpent.com/indexfb.htm>

**SERPENT ADVANCED MANUALS** <http://promo.serpent.com/sam/>

## SERPENT SOCIAL MEDIA



[www.facebook.com/SerpentMRC](http://www.facebook.com/SerpentMRC)



[www.youtube.com/user/SerpentMRC](http://www.youtube.com/user/SerpentMRC)



[www.twitter.com/SerpentMRC](http://www.twitter.com/SerpentMRC)



[www.plus.google.com/+SerpentModelcars/posts](http://www.plus.google.com/+SerpentModelcars/posts)



[www.weibo.com/teamserpent](http://www.weibo.com/teamserpent)

# SPYDER SRX2 MHT



#80466 1 Manual SRX2 MHT