

# SRX8GT

1/8 SCALE

**Instruction  
Manual**



**SERPENT**



## **INTRODUCTION**

Thank you very much for selecting this Serpent rc car and thus become a member of the ever growing worldwide Serpent racing family. Serpent started in 1980 and has been growing its product-line and fan-base ever since.

The Serpent Cobra SRX8 GT is a state of the art 1/8 scale 4wd GT which will give you the true Serpent racing experience. The assembly manual will guide you through all the steps to complete the car, so you can hit the track with a good base-set-up soonest. The Serpent design department succeeded to create a superbly performing car combined with eas of assembly and maintenance. The high quality standards of all parts and hardware will make racing your Serpent car a very rewarding activity !

Through our team, website and social media we will keep you up-to-date on all developments of the Serpent cars. We hope to meet you on the track and through our various media! Enjoy the drive !

Team Serpent  
Multiple World Champions

## **INSTRUCTIONS**

Serpent's long tradition of excellence extends to the instruction manuals, and this instruction manual is no exception. The easy-to-follow layout is richly illustrated with 3D-rendered full-color images to make your building experience quick and easy. Following the instructions will result in a well-built, high-performance race-car that will soon be able to unleash its full potential at the racetrack. The kit includes bags, with bagnumbers, which refer to the same step in the manual. Open only the indicated bag(s) per step and finish that part of the assembly. Remaining parts will be needed lateron in the assembly process.

## **PLASTIC PARTS**

The Serpent moulded parts are very durable and hard. When assembling longer screws in new composite parts, make sure to use new hex bits in your (power) tools. Pre-threading also helps to avoid screw damage.

## **SETUP**

In certain assembly steps you need to make basic adjustments, which will give you a good initial setup for your Serpent Cobra SRX8 GT. Fine-tuning the initial setup is an essential part of building a high-performance racecar like your Serpent Cobra SRX8 GT.

## **EXPLODED VIEWS AND PARTS LIST**

The exploded views and parts lists for the Serpent Cobra SRX8 GT are presented in the Reference Guide section in the back of this manual. The exploded views show all the parts of a particular assembly step along with the Serpent part number and hotlink to the Serpent website. Partnumbers in orange indicates that this part is an optional. Optionals part names and numbers are showed below.

## **CUSTOMER SERVICE**

Serpent has made a strong effort to make this manual as complete and clear as possible. Additional info may be published in our website: [www.serpent.com](http://www.serpent.com) or you may ask your dealer or the Serpent distributor for advice, or email Serpent direct: [info@serpent.com](mailto:info@serpent.com). The Serpent Facebook, Twitter and Youtube pages give additional means of support and communications.

## **SAFETY**

Read and take note of the 'Read this First section' before proceeding to assemble the car-kit. This car-kit is intended for persons aged 16 or older.

## **READ THIS FIRST!**

- This is a highly technical hobby product, intended to be used in a safe racing environment. This car is capable of speeds in excess of 80 km/h or 50mph. Please follow these guidelines when building and operating this model.
- Parental guidance is required when the builder/user of this car is under 16.
- Follow the building instructions. If in doubt, contact your dealer or importer.
- Be sure to use the proper tools when assembling the car. Always exercise caution when using electric tools, knives and other sharp objects.
- Be careful when using liquids like lubrication oil, fuel or glue. Do not swallow.
- Follow the manufacturer's instruction in case you experience irritation after using the product.
- Be careful when operating the car. Stay away from any rotating parts such as wheels, gears and transmission. Stay away from motor, engine and exhaust pipe system or speedo during and immediately after use, as these parts may be very hot. We advise to use protective hand cloves.
- Only operate this car in a safe environment, like a special racing track or a closed parking lot. Avoid using this car on public roads, crowded places or near infants.
- Before operating this car, always check the mechanical status of the car. Also check that the transmitter and receiver frequencies correspond and are not used by any other racer at the same time. Check that the batteries of the transmitter and receiver- are fully charged.
- After use, always check all the mechanics of the car. We advise to clean the car immediately after use, and inspect the parts for wear or fractures. Replace when necessary. Do not use water, methanol, thinner or other solvents to clean the car.
- Empty the fuel tank (depending on model) if needed and disconnect the receiver battery.
- Store the car in a dry and heated place to avoid corrosion of metal parts.
- Avoid using this car in wet conditions as the water will cause corrosion on the metal parts and bearings and these parts will cease to function properly. If driven in the wet, ensure that all the electric equipment is waterproofed and after use, that all moving parts are dried immediately.

## **CONTENTS**

• <b>FR/RR DIFF ASSEMBLY</b>	<b>4</b>
• <b>GEARBOX ASSEMBLY</b>	<b>6</b>
• <b>CENTRAL ASSEMBLY</b>	<b>8</b>
• <b>REAR ASSEMBLY</b>	<b>10</b>
• <b>FRONT ASSEMBLY</b>	<b>16</b>
• <b>STEERING ASSEMBLY</b>	<b>22</b>
• <b>CLUTCH ASSEMBLY</b>	<b>25</b>
• <b>RADIO ASSEMBLY</b>	<b>27</b>
• <b>SHOCKS ASSEMBLY</b>	<b>31</b>
• <b>FINAL ASSEMBLY</b>	<b>35</b>
• <b>EXPLODED VIEWS</b>	<b>39</b>
• <b>TEAM SERPENT NETWORK</b>	<b>51</b>

## LINES DESCRIPTION

Each step contains a variety of numbers, lines, and symbols. The numbers represent the order in which the parts should be assembled. The lines are described below.



Step number; the order in which you should assemble the indicated parts



Length after assembly



Assembly path of one item into another



Group of items (within lines) should be assembled first



Direction the item should be moved



Glue one item to another



Press/insert one item into another



Connect one item to another



Gap between two items

## ICONS DESCRIPTION

Each step contains a variety of symbols described below.



Carefull, read and check very well.



Apply a small amount of cyano glue. Use wear protection for eyes and hands.



Detail view to explain assembly or order of parts better.



Default set-up: This symbol indicates the default setup.



Grease: apply a small amount of grease to the parts shown.



Left and right parts should be assembled in the same way.



Thread lock: apply a small amount on the parts shown. Before to apply the threadlock, make sure to degrease the parts very well, as otherwise the threadlock will not work.



Silicone oil: use the indicated silicone oil for the shocks and differentials.



Parts or items not included in the kit.



Optional part, not standard in the kit.

## STEP 1 FR/RR DIFF BAG

## STEP 2

**1.1**

**6x11.75x0.2**

**2.5x12**

**M3x4**

**8x16x5**

**GR**

Note the correct pin location.

**1.2**

**8x16x5**

**GR**

**SO** Use silicone oil to hold seal in position.

**2.5x12**

**6x11.75x0.2**

Note the correct pin location.

**2.1**

**VOLUME COMPENSATORS**

When the differential gets hotter, the foam inserts will absorb the pressure of the expansion of the oil.

1- The supplied foam tube must be cut to size as indicated here below.

2- Penetrate them fully with same differential oil.

3- Insert them in the compensator holes.

14.7 - 14.9 mm

**2.2**

Add just enough oil to cover the large gear before assembling the small satellite gears and cross pins.

Use the silicone oil supplied in the kit. For the correct cst value please check the default setupsheet.

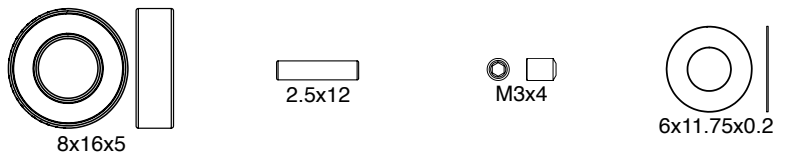
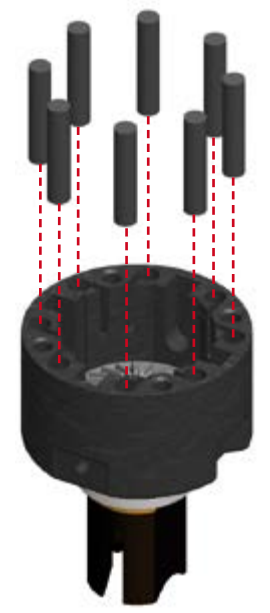



**STEP 3**

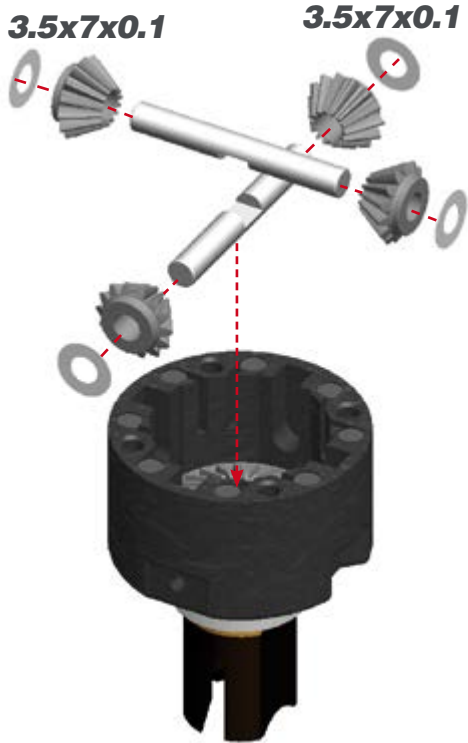

**STEP 4**



Fill the differential with silicone oil 1 mm above the crosspin, do NOT overfill. Use the silicone oil supplied in the kit. For the correct cst value please check the default setupsheet.

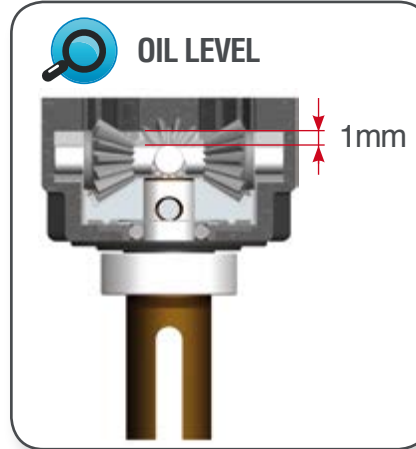

**AMOUNT OF OIL IN THE DIFFS**

Use a digital scale to measure the exact amount of oil in the diff.

Differential weight with volume compensators = 40.15 grams

Differential weight without volume compensators = 40.35 grams



**STEP 5**

**M3x14**

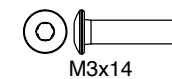
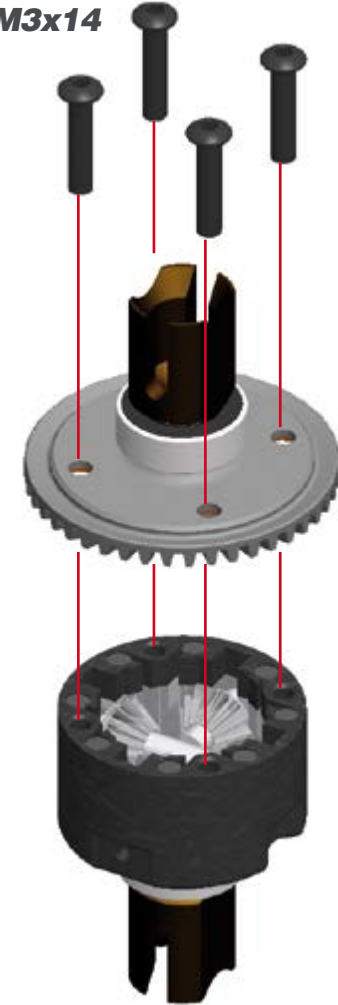

## STEP 6

### BAG 1

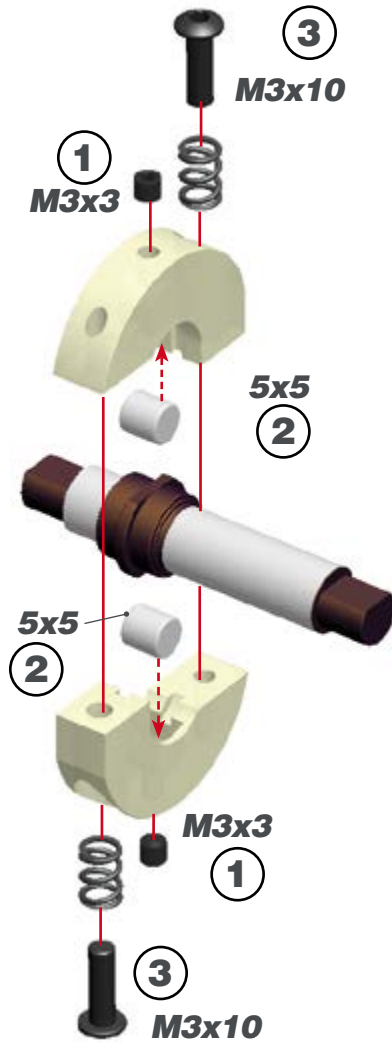

**!** 1- The M3x10 screw adjust the SHIFT POINT. As default adjustment screw it in all the way (do not overtighten to avoid spring deformation), then unscrew 3 turns.

2- Adjust the M3x3 screw to minimise the gap between the shoes and the bell, but still spinning free without touching. Check after each run.

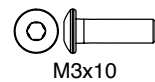
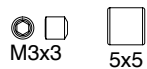
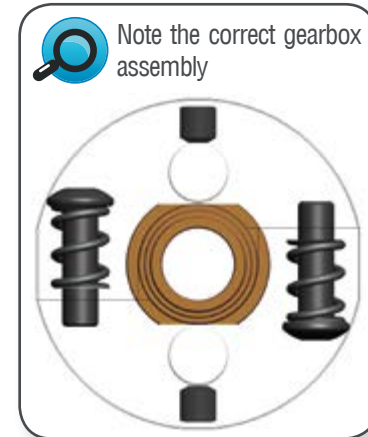

## STEP 7

### 7.1

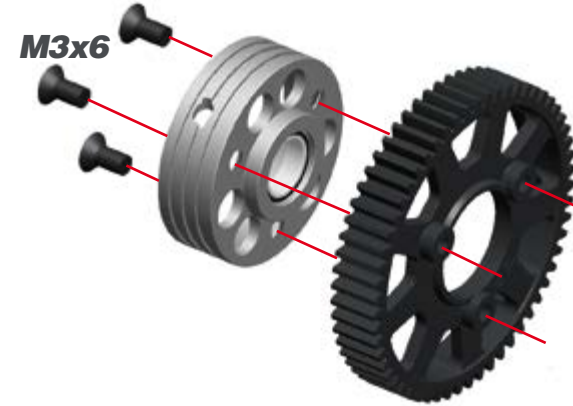

### 7.2

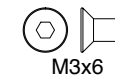



**STEP 8**

**8.1**

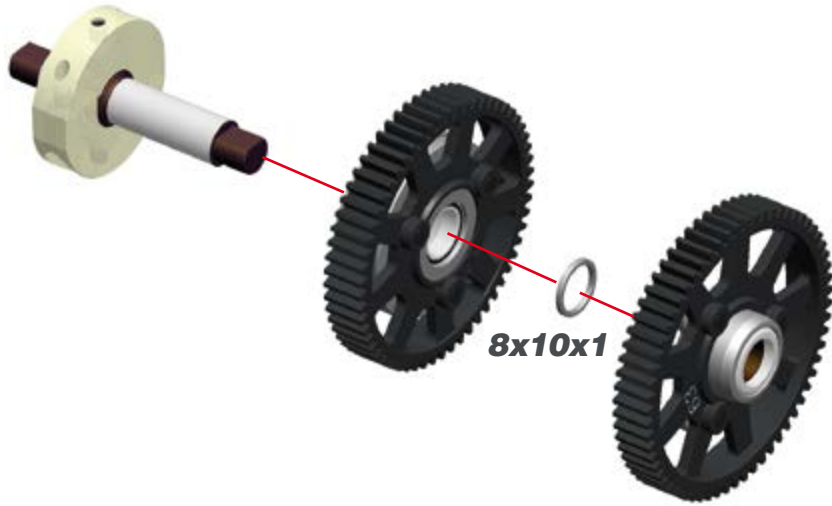

**8.2**

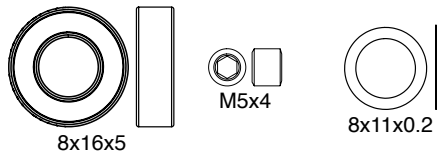
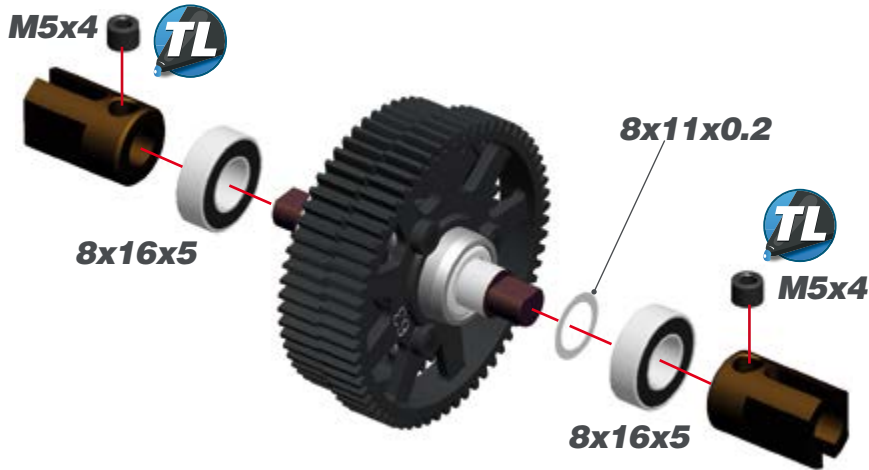

**STEP 9**

**BAG 2**

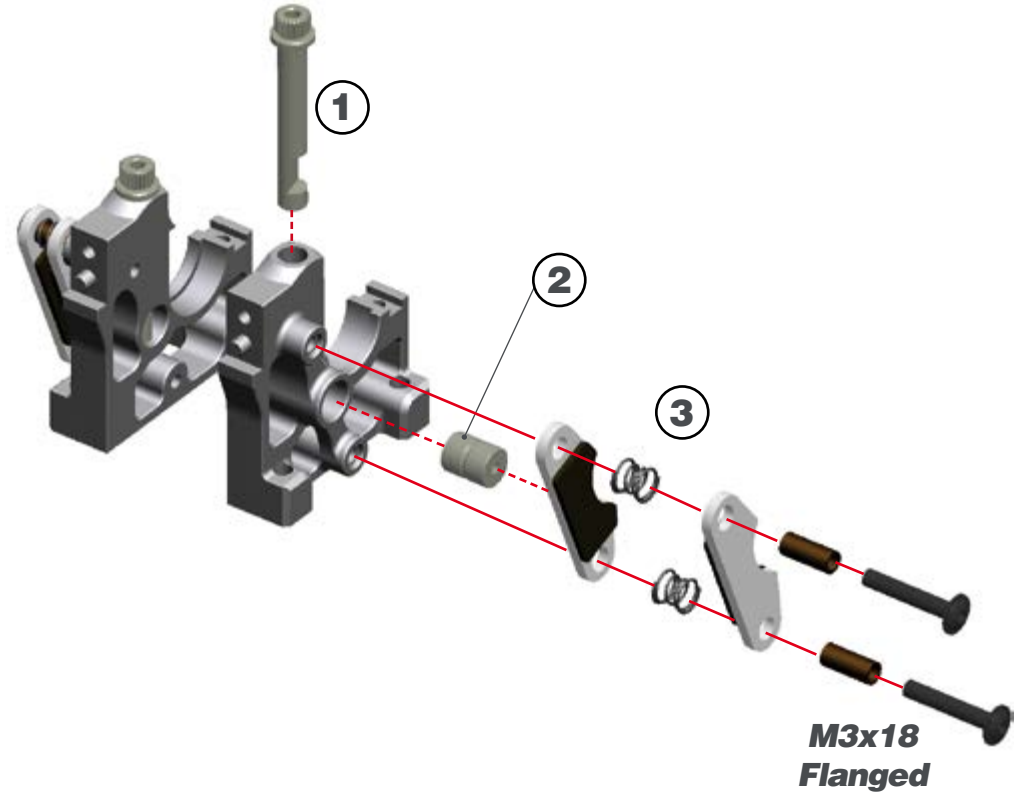

**STEP 10**

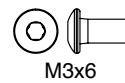
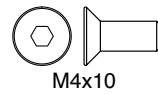
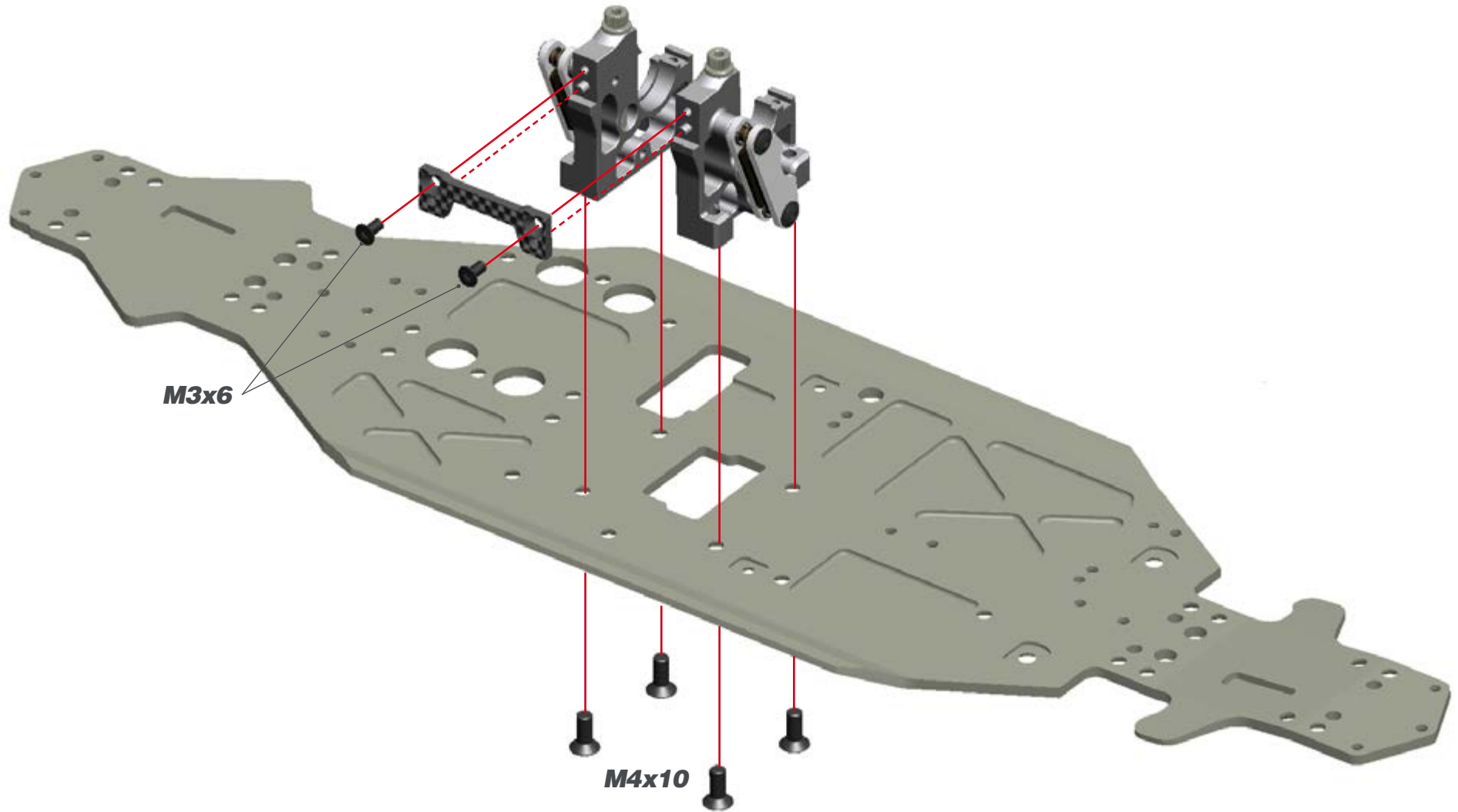



**STEP 11**

**STEP 12**

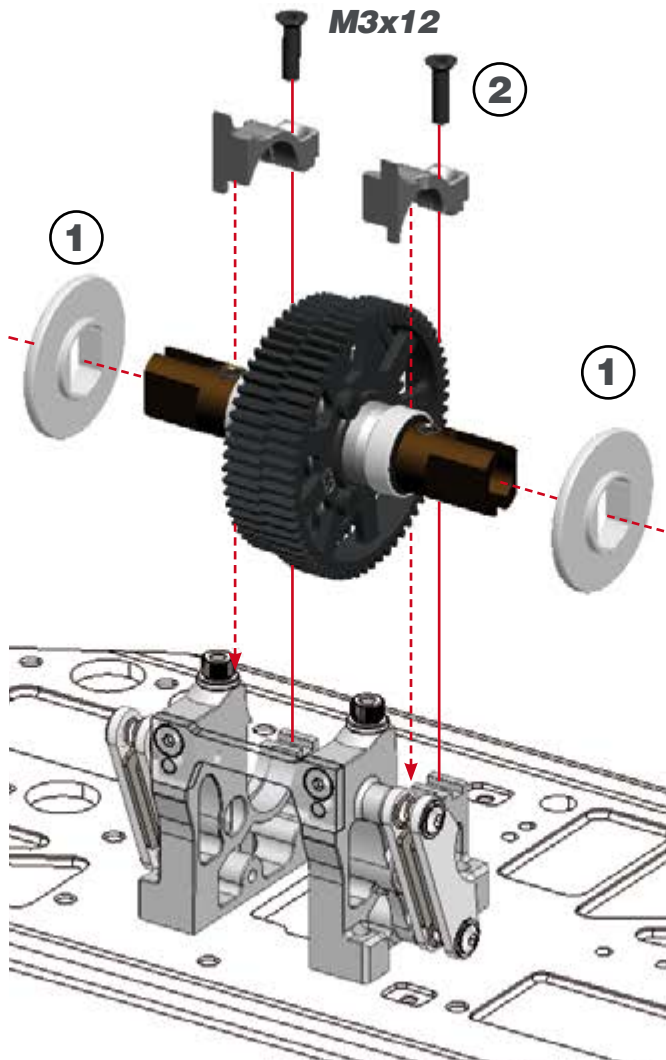

**12.1**

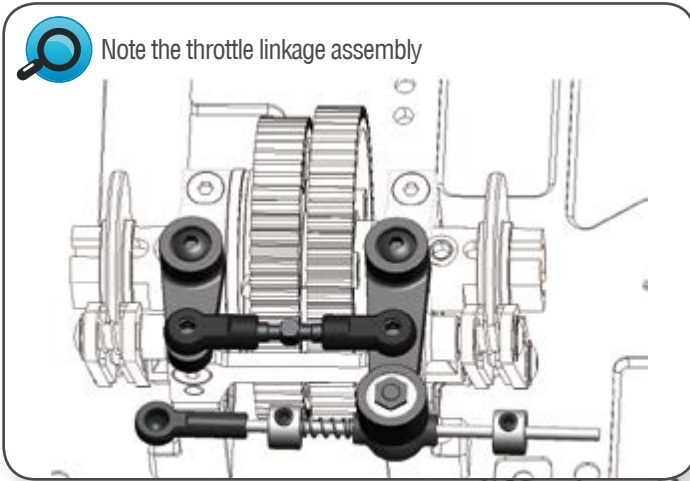
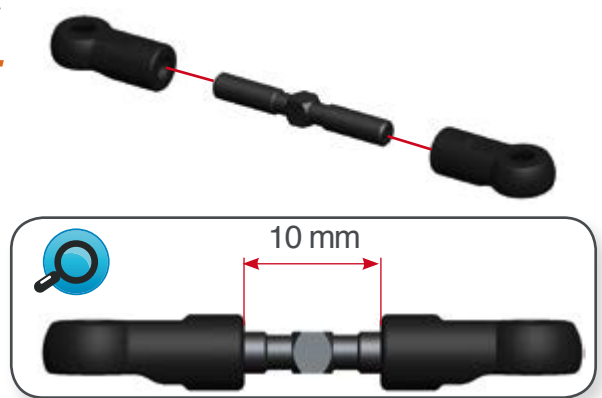

**12.2**

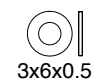
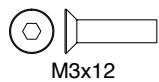
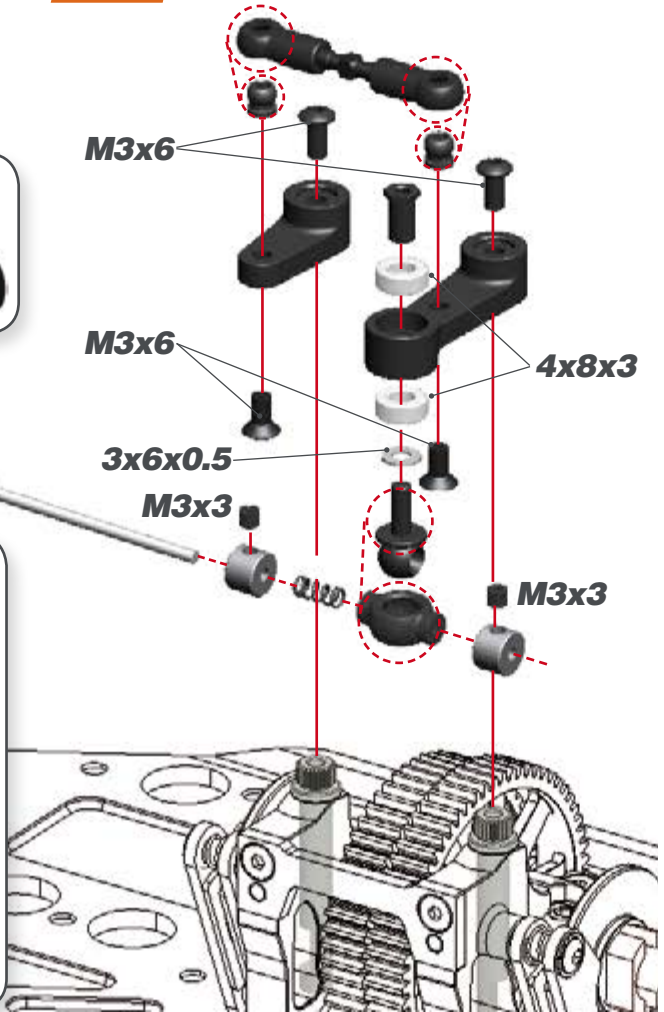

## STEP 13

BAG 3

## STEP 14

### 13.1 L=R



Tighten anti-roll bar cap until there is no play, and it moves freely.

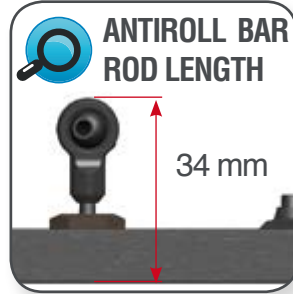

### 13.2

M2.5X6

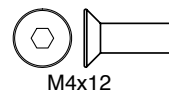
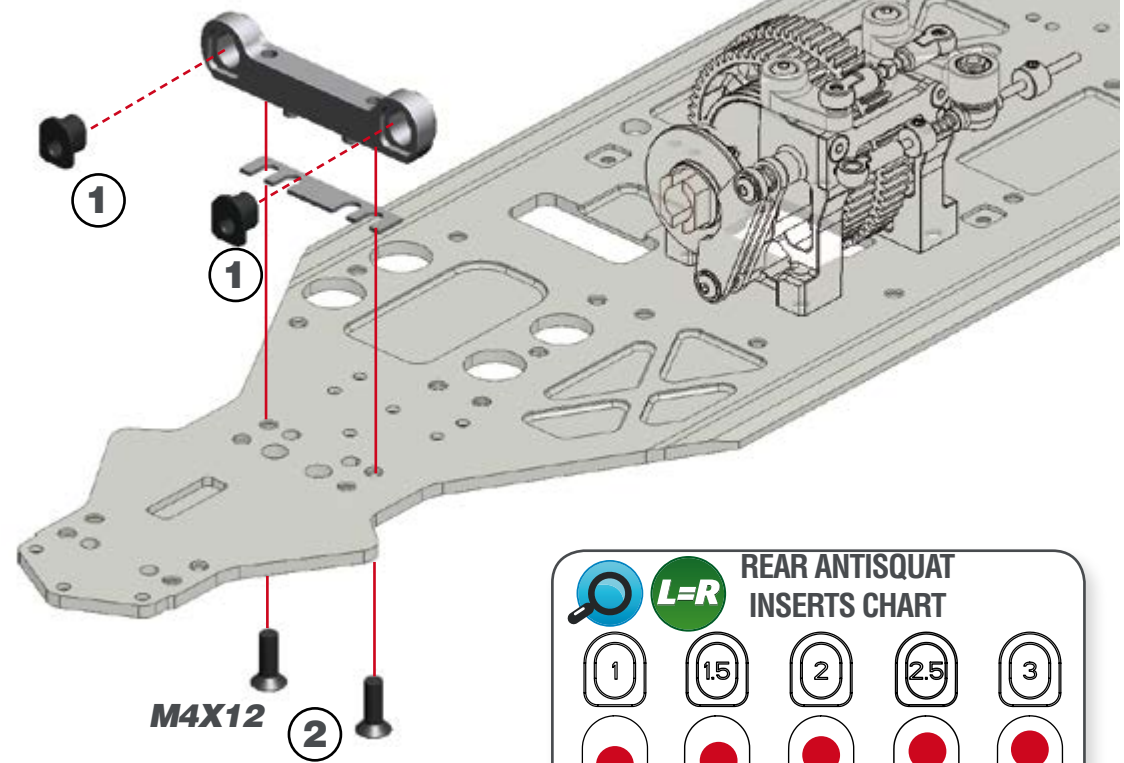
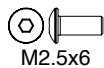
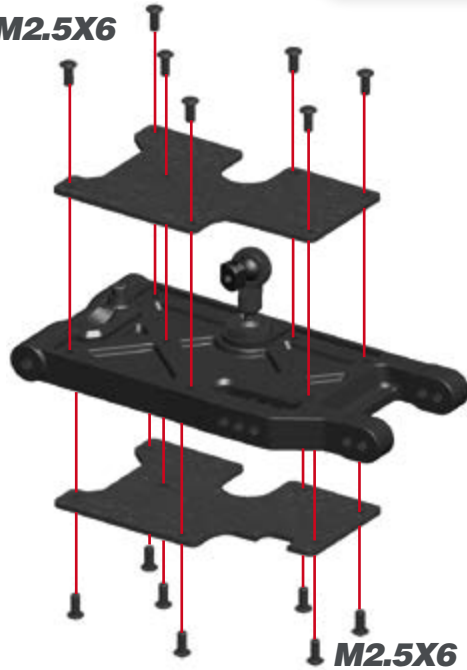

**REAR ANTISQUAT INSERTS CHART**

L=R

1	15	2	2.5	3
●	●	●	●	●

DEF. SETUP



**STEP 15**

**STEP 16**

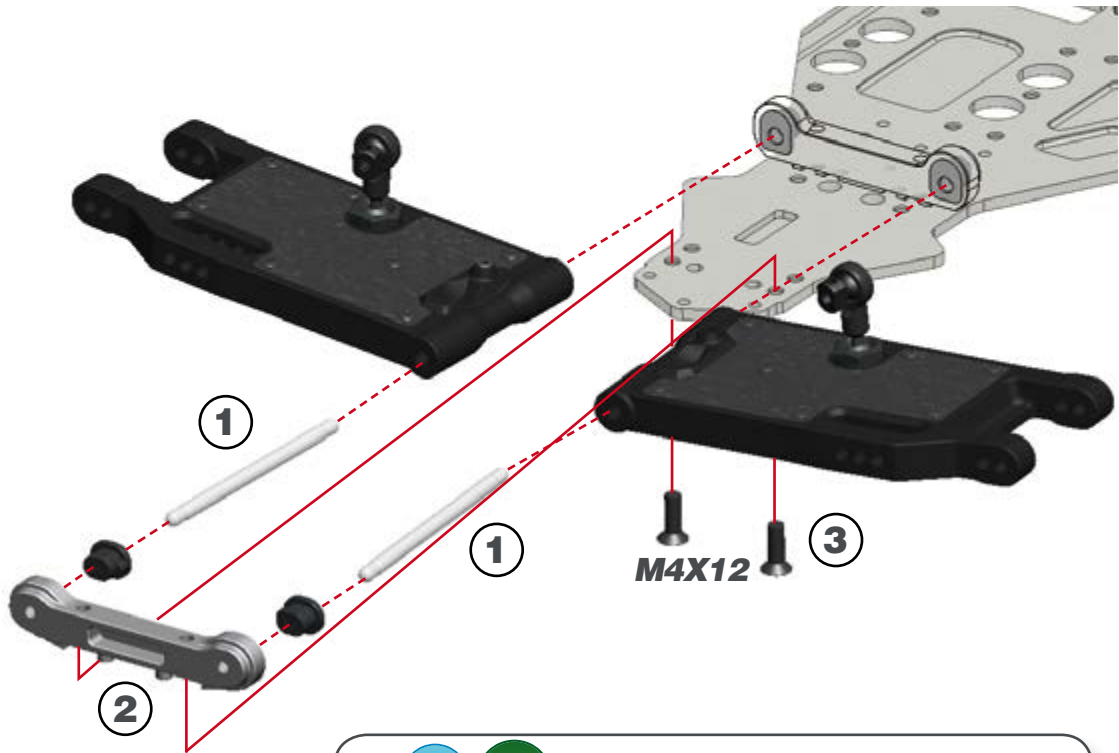

**L-R REAR TOE IN INSERTS CHART**

2	2.5	2.75	3	3.25	3.5	4
●	●	●	●	●	●	●

**DEF. SETUP**

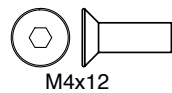
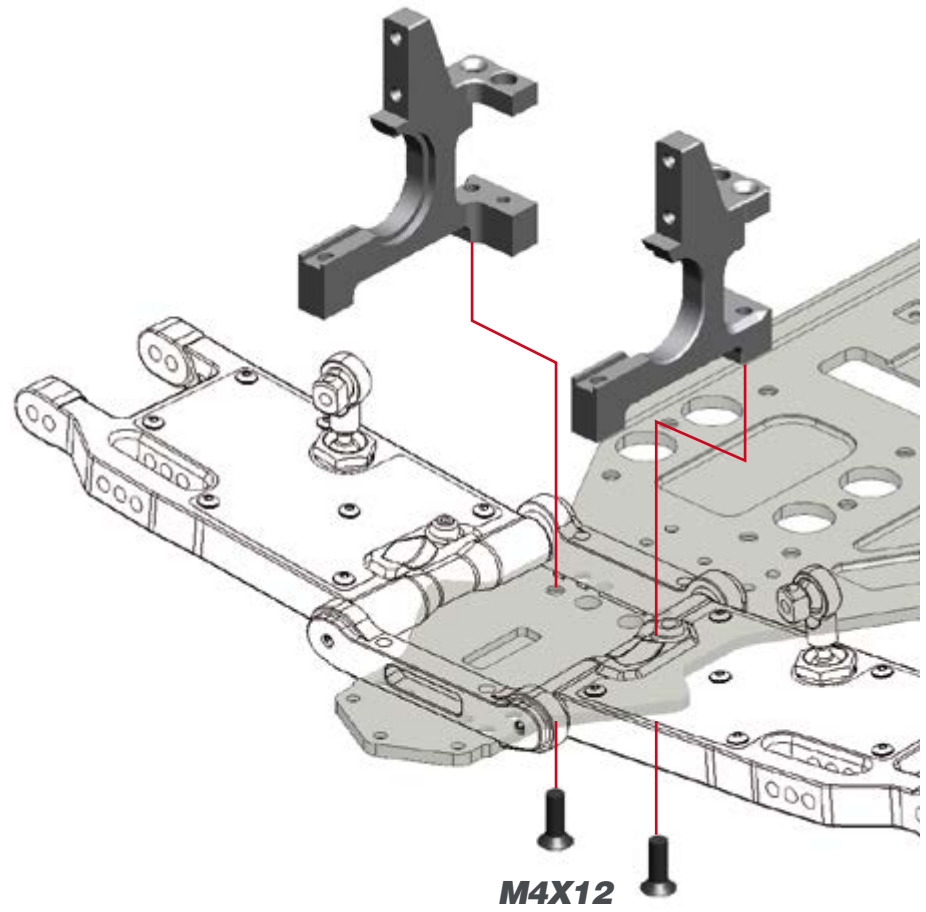

**STEP 17**

**BAG 4**

**17.1**

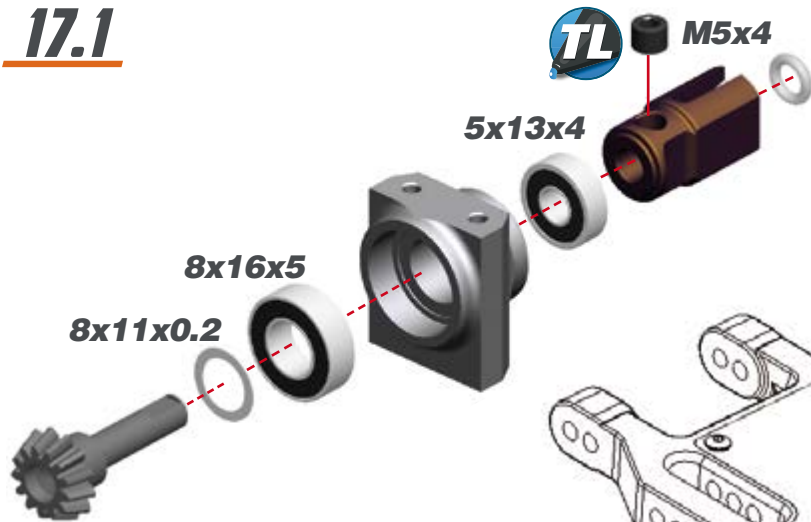

**!** After building the differential with new gears, new differential case and bearings, the diff may feel a little tight. The connected parts need at least an hour run-time to create a perfect match. Attention: When you assemble the diff with too much initial play, the gears will not run-in properly and may wear quickly. After 1 or 2 hours of running the car, re-check the gear-mesh between the ring gear and the pinion. All parts should have run-in properly now. You may add or remove 8x11x0.1 shims as needed.

**17.2**

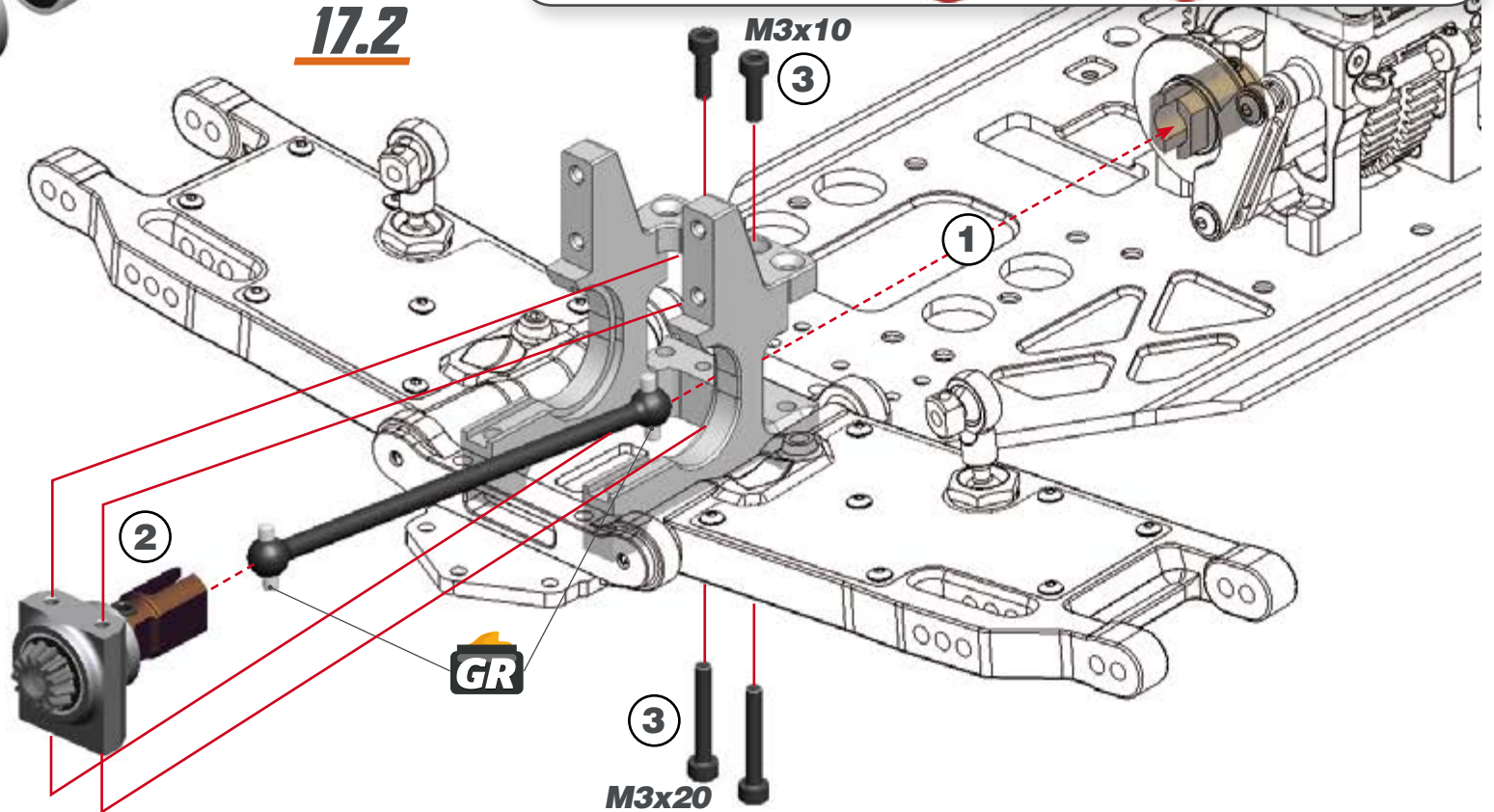

**INDRIVE BRACKETS CHART**  
Assemble the indrive bracket accordingly to the diff insert asert mounted in the step 18.

	<b>LOW</b>		<b>MID LOW</b>		<b>MID HIGH</b>		<b>HIGH</b>
			<b>NI</b>		<b>NI</b>		

**DEF. SETUP**

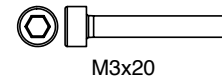
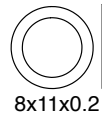
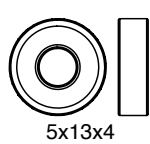
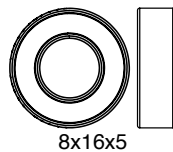



**STEP 18**

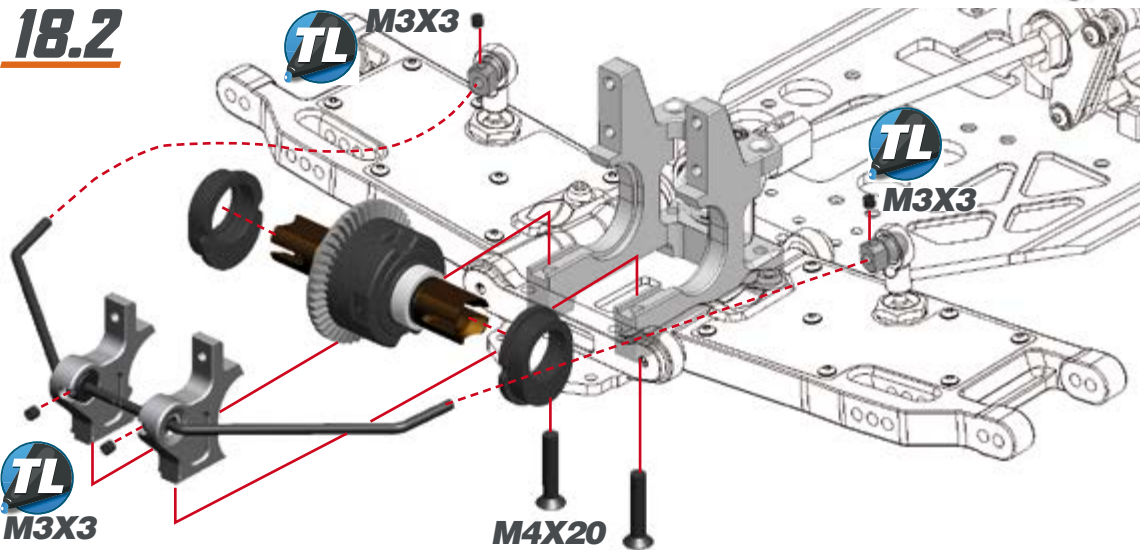

**DIFF INSERTS CHART**

**DEF. SETUP**

	<b>LOW</b>		<b>MID LOW</b>		<b>MID HIGH</b>		<b>HIGH</b>
--	------------	--	----------------	--	-----------------	--	-------------

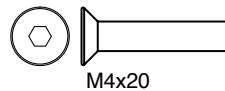

**STEP 19**

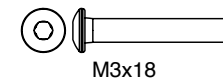
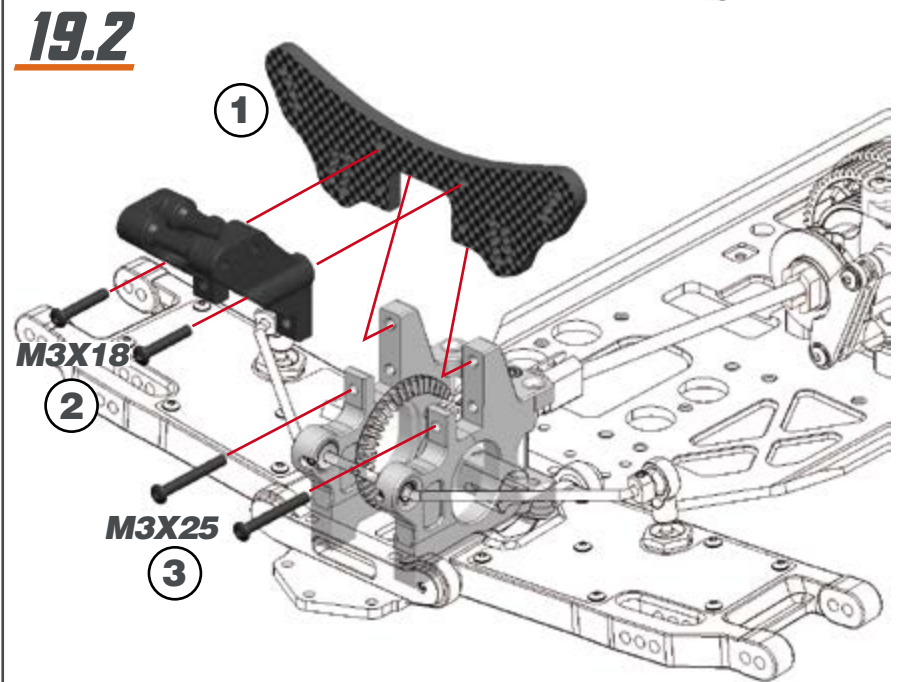
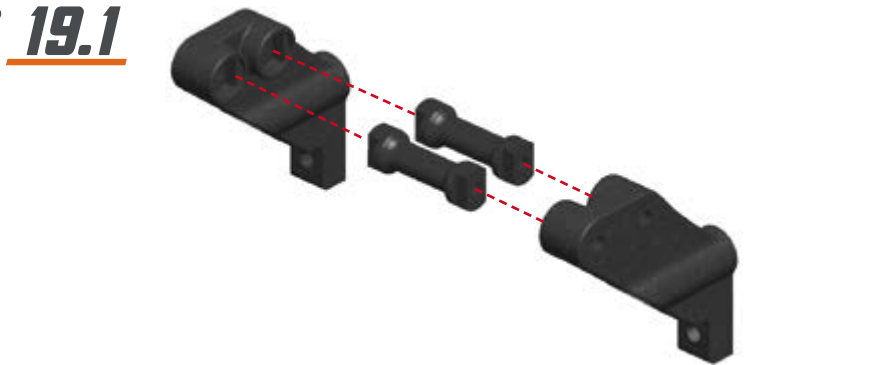

**STEP 20**

**BAG 5**

**20.1** L-R

**20.2**

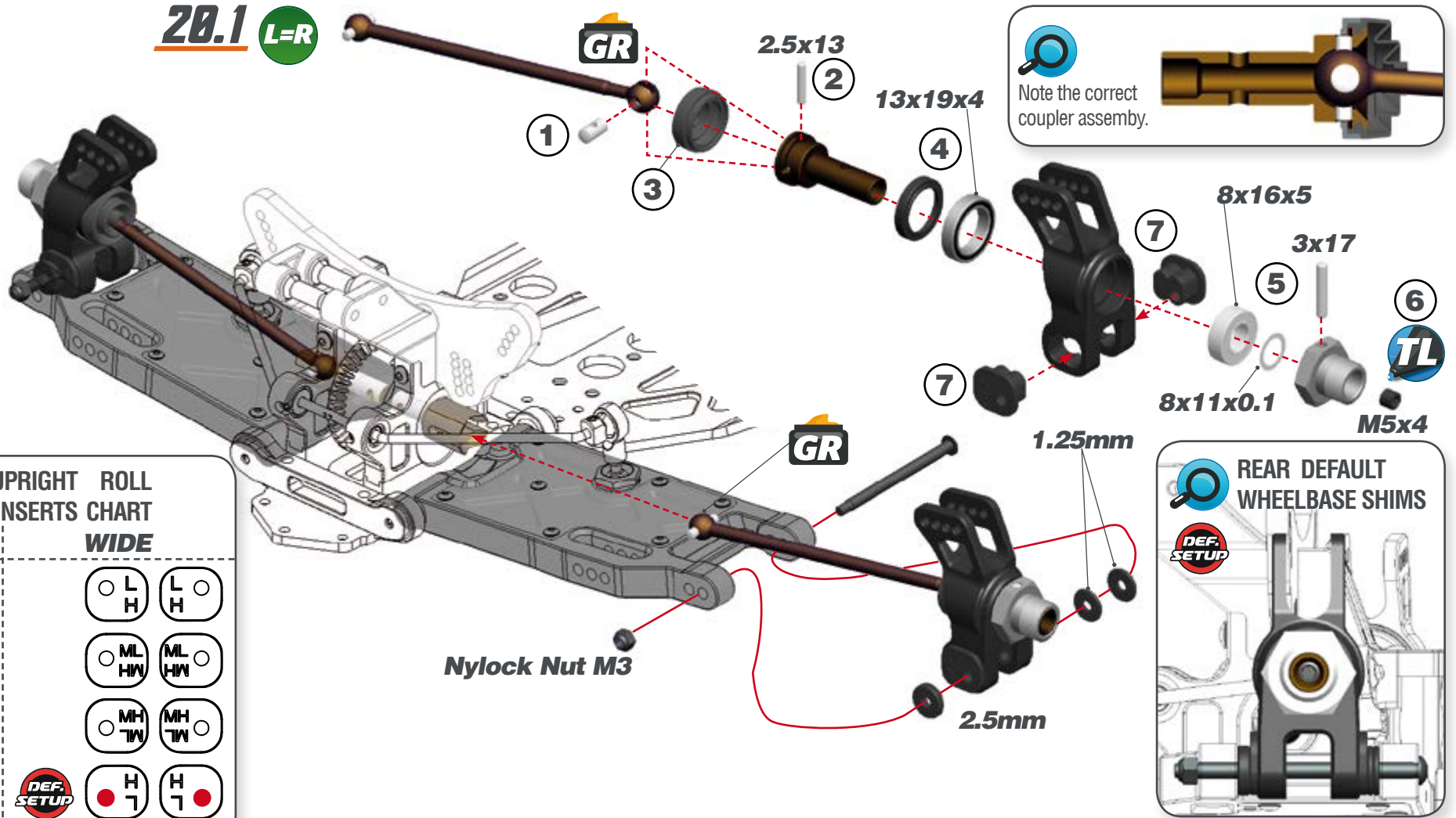

**REAR UPRIGHT ROLL CENTER INSERTS CHART**

NARROW		WIDE	
L H	L H	L H	L H
ML HW	ML HW	ML HW	ML HW
MH TW	MH TW	MH TW	MH TW
H T	H T	H T	H T

**DEF. SETUP**

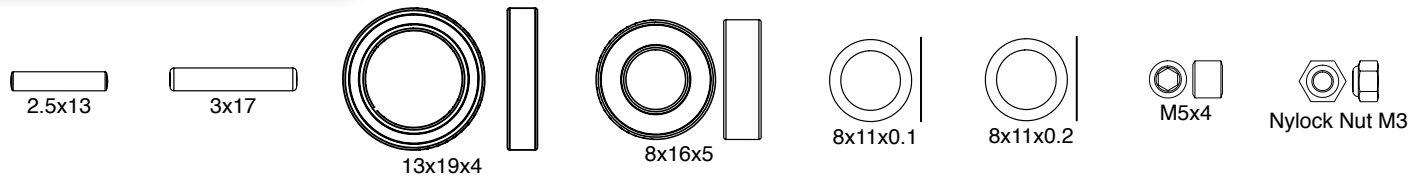

**STEP 21**

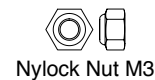
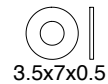
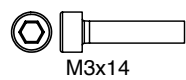
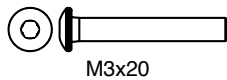
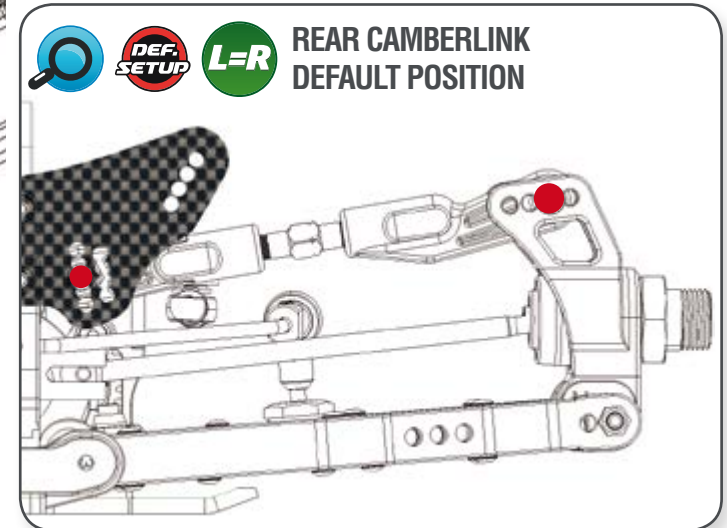
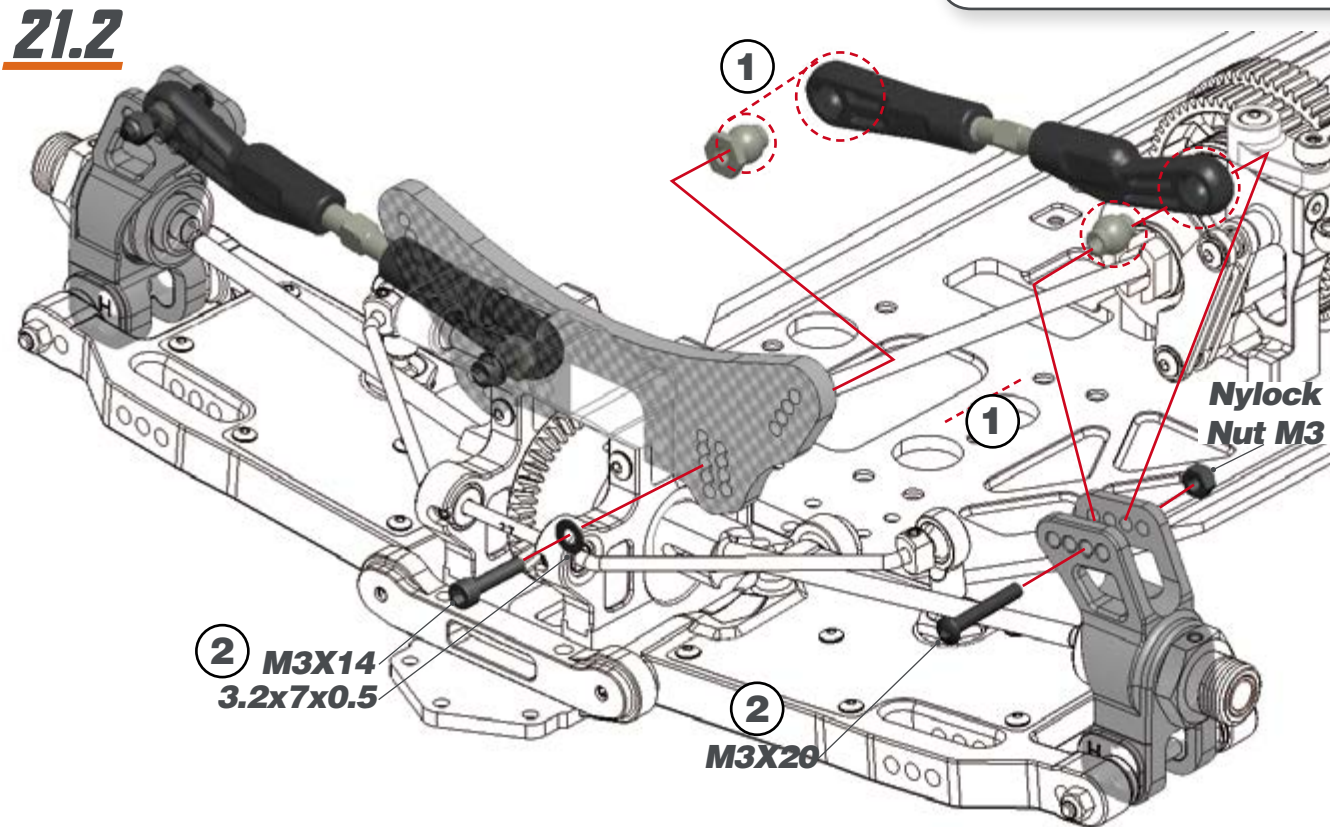
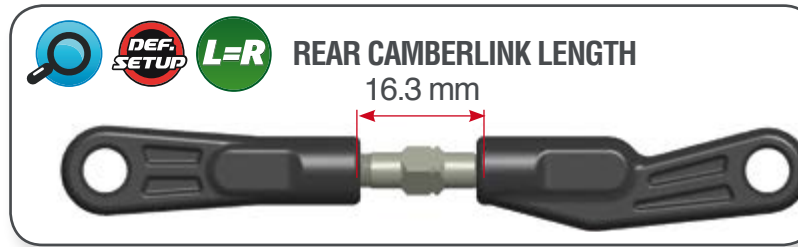



## STEP 22

BAG 6

## STEP 23

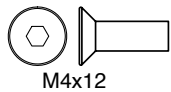
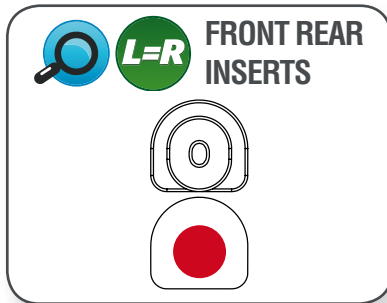
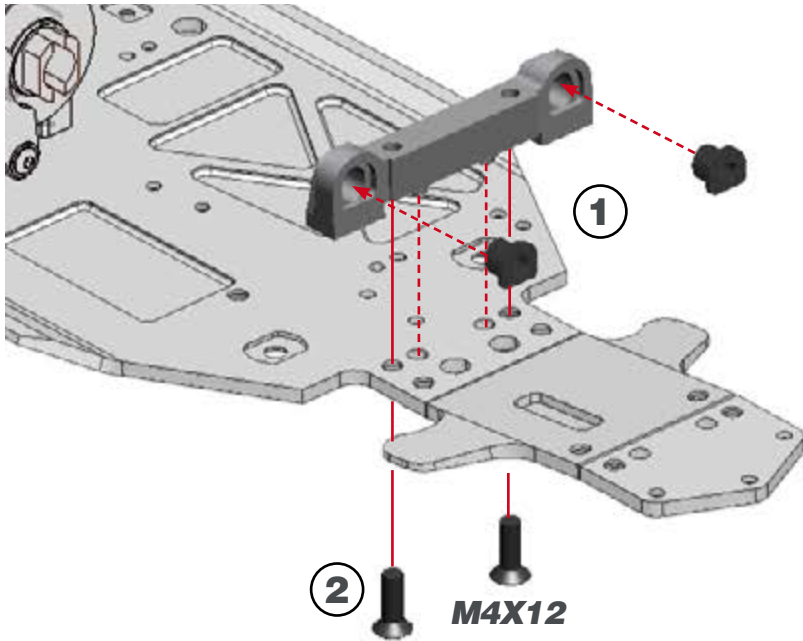

### 23.1



Tighten anti-roll bar cap until there is no play, and it moves freely.



### 23.2

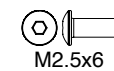
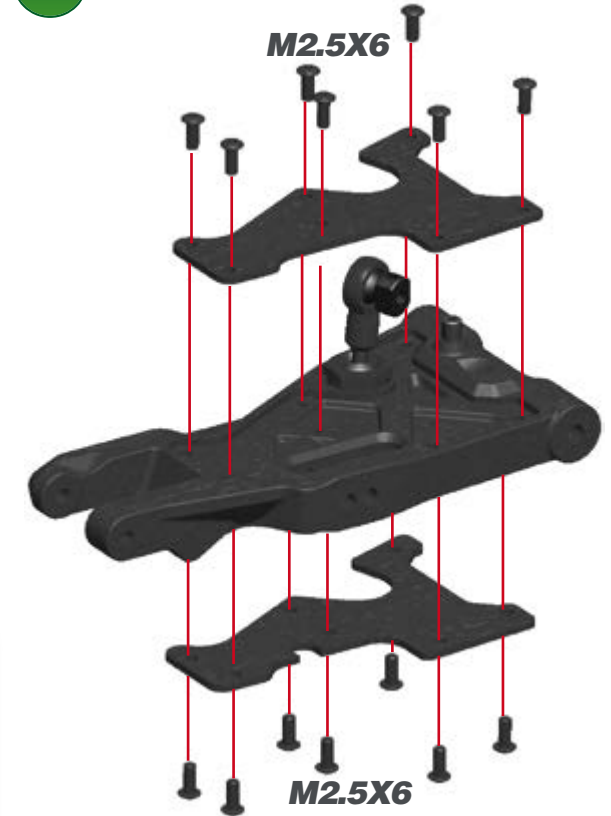

**STEP 24**

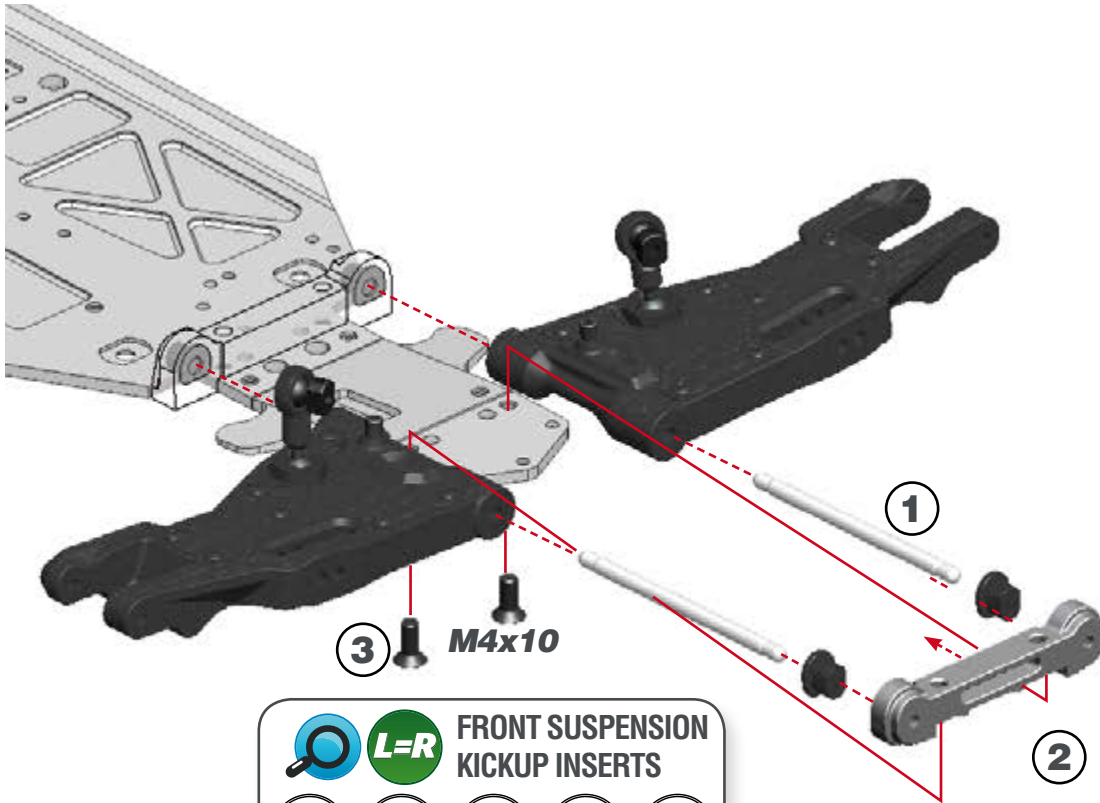

**FRONT SUSPENSION KICKUP INSERTS**

**L=R**

9	9.5	10	10.5	11
●	●	●	●	●

**DEF. SETUP**

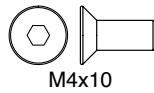

**STEP 25**

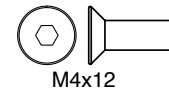
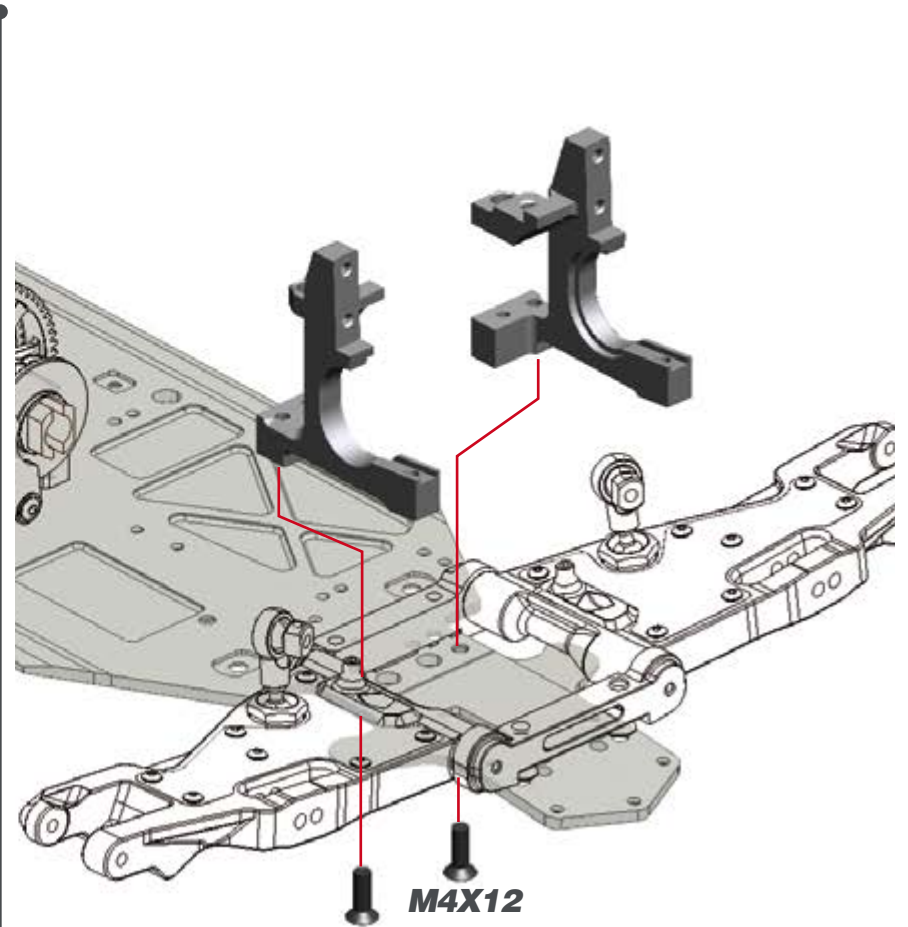

**STEP 26**

**BAG 7**

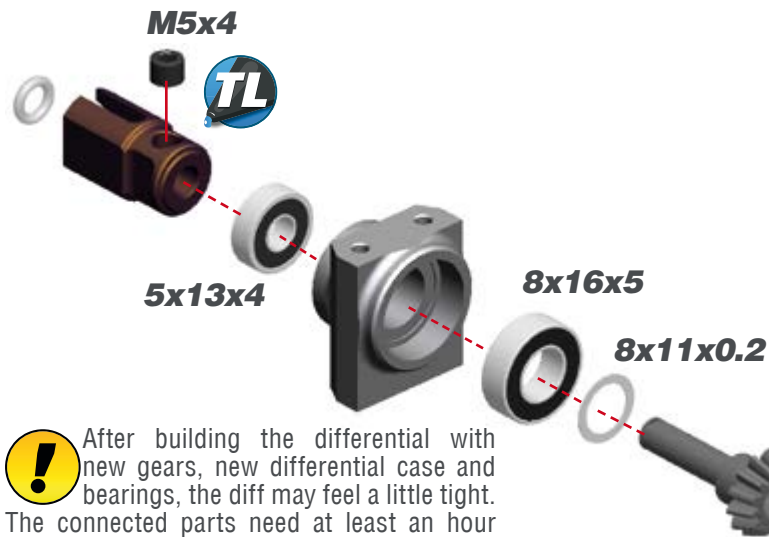

**!** After building the differential with new gears, new differential case and bearings, the diff may feel a little tight. The connected parts need at least an hour run-time to create a perfect match. Attention: When you assemble the diff with too much initial play, the gears will not run-in properly and may wear quickly. After 1 or 2 hours of running the car, re-check the gear-mesh between the ring gear and the pinion. All parts should have run-in properly now. You may add or remove 8x11x0.1 shims as needed.

**INDRIVE BRACKETS CHART**  
Assemble the indrive bracket accordingly to the diff insert assert mounted in the step 18.

	<b>LOW</b>		<b>MID LOW</b>		<b>MID HIGH</b>		<b>HIGH</b>
			<b>NI</b>		<b>NI</b>		

**DEF. SETUP**

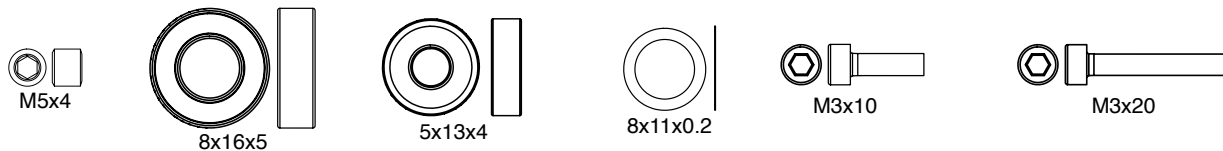
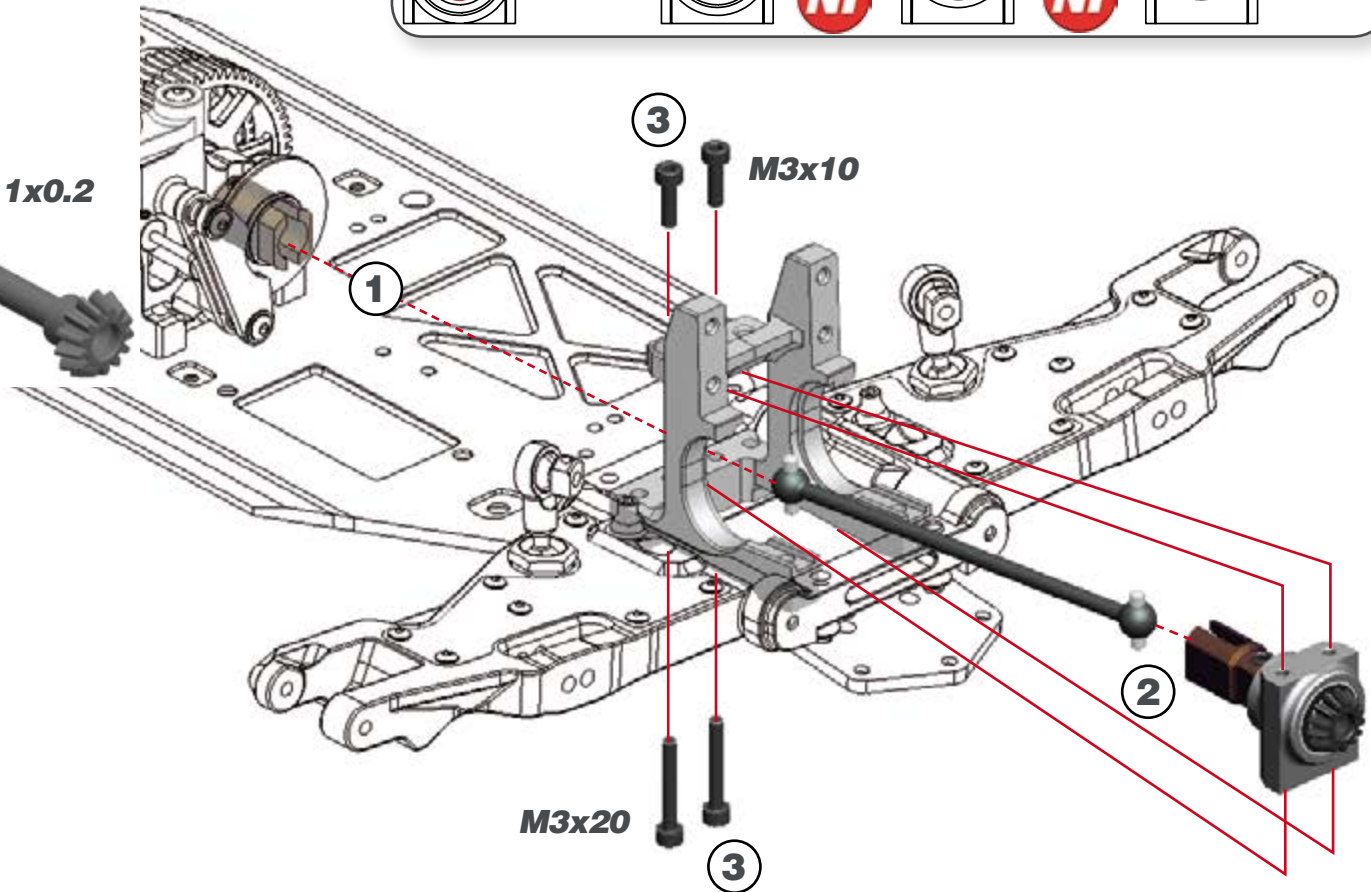



**STEP 27**

**27.1**

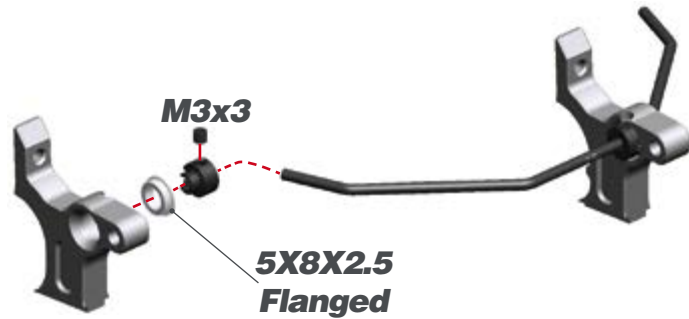

**27.2**

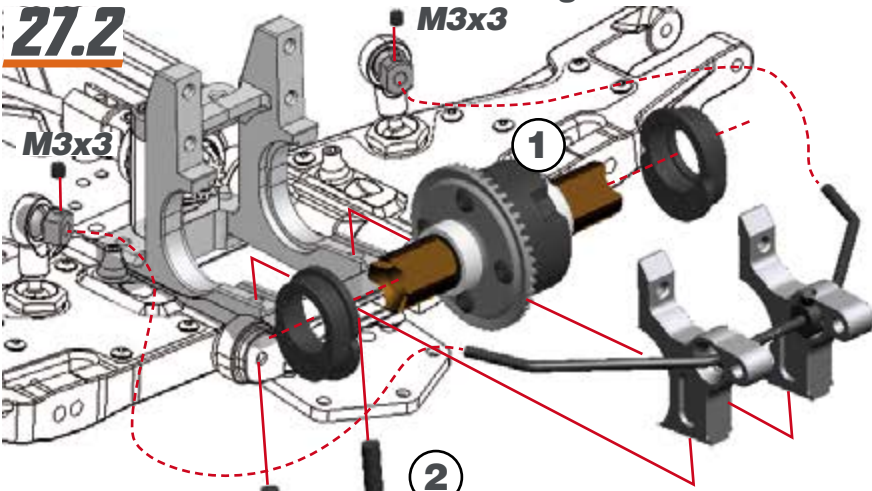

**DIFF INSERTS CHART**

**DEF. SETUP**

**LOW** **MID LOW** **MID HIGH** **HIGH**

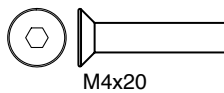

**STEP 28**

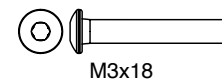
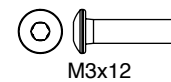
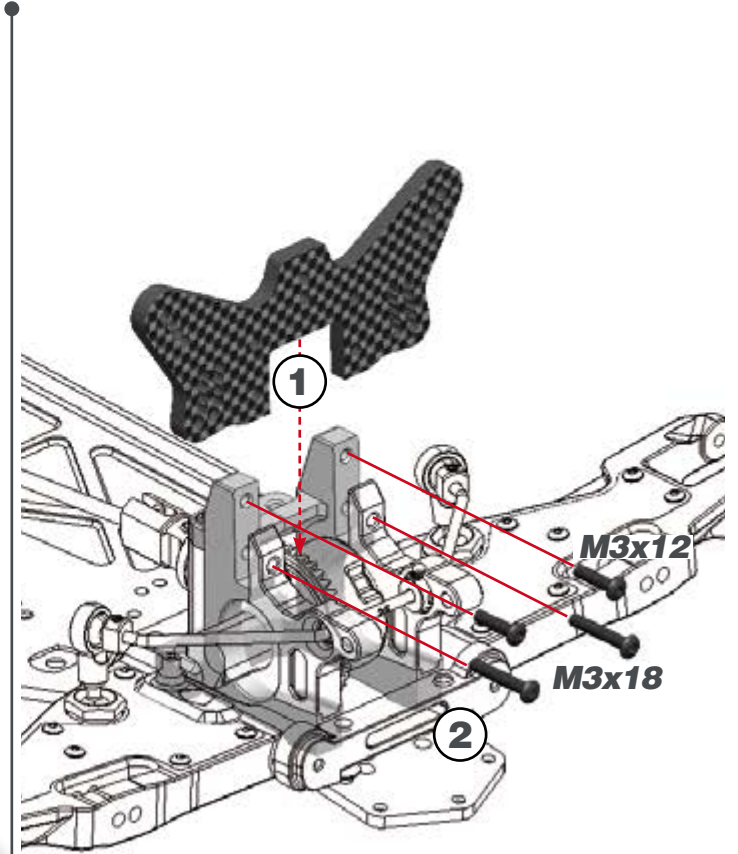

**STEP 29 BAG 8**

**29.1** L=R

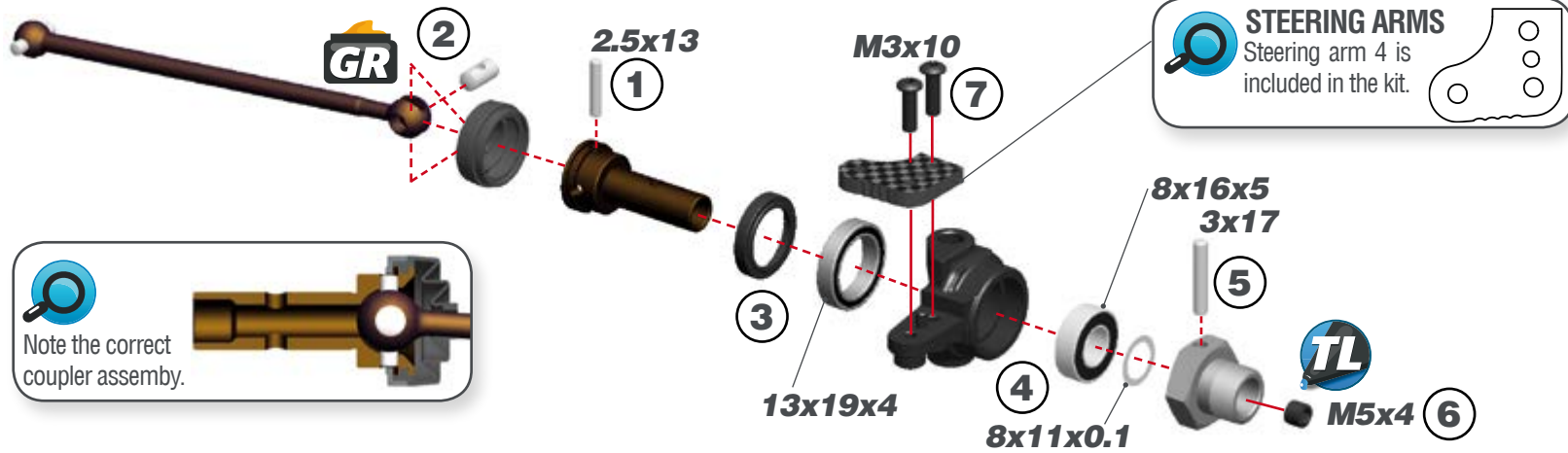

**29.2**

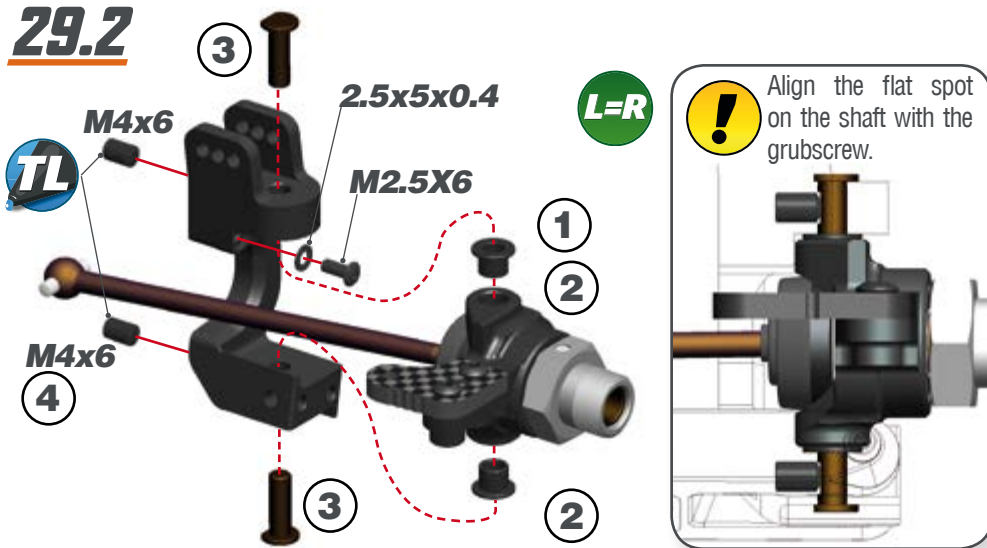

**29.3**

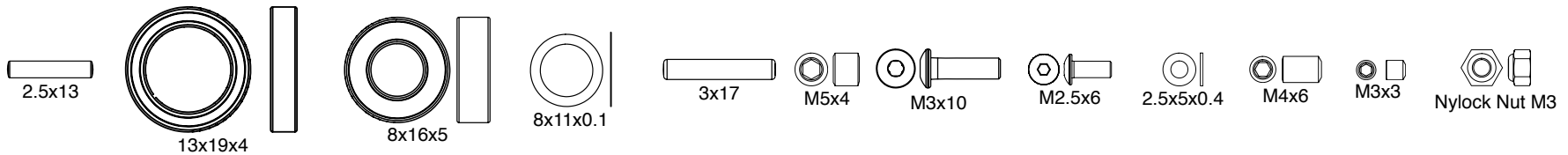
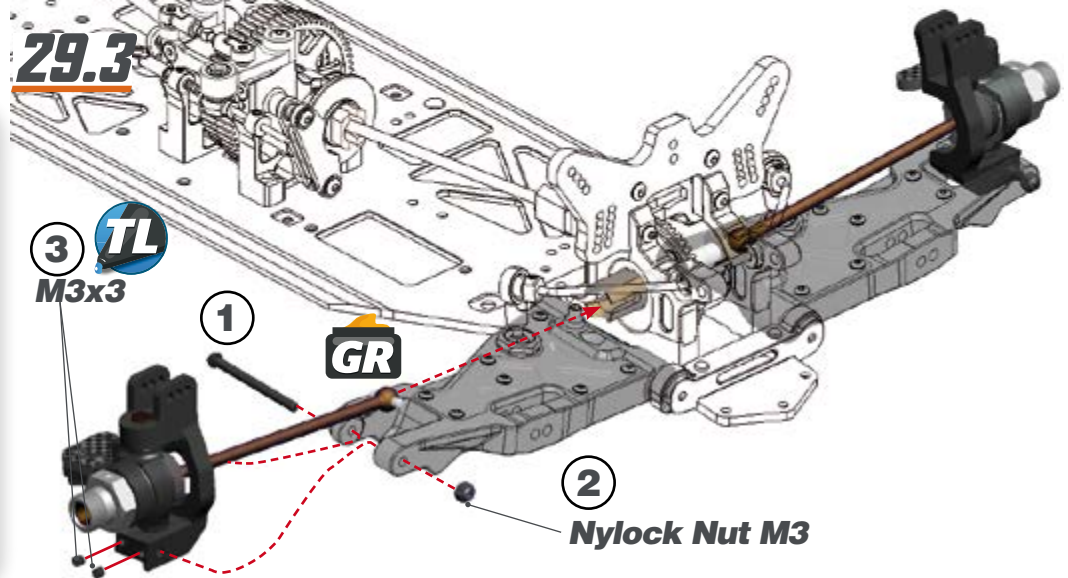

**STEP 30**

**30.1**

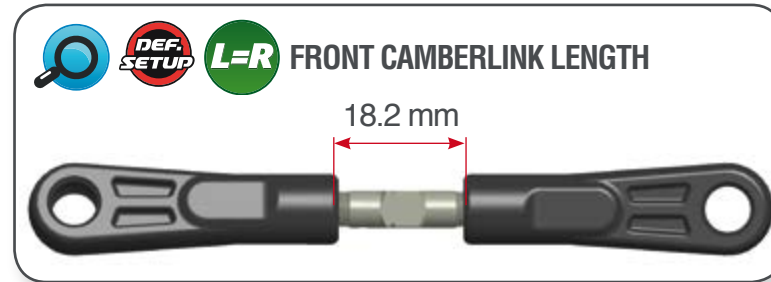

**30.2**

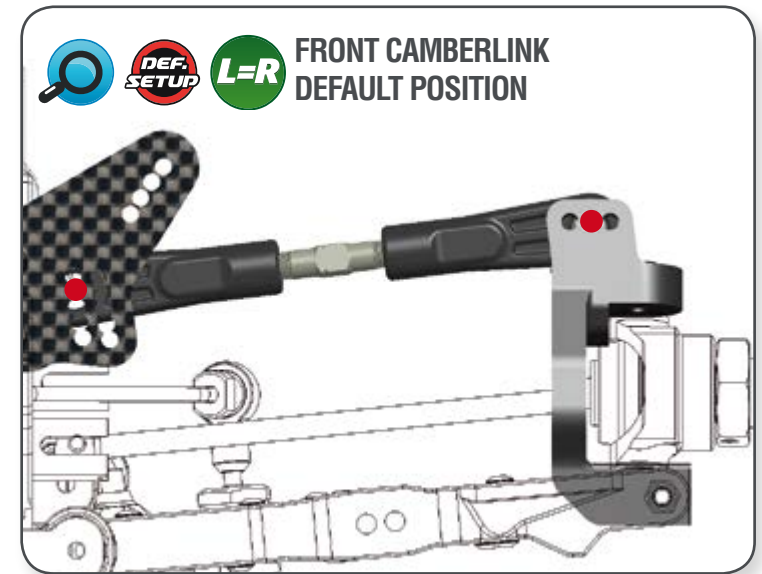
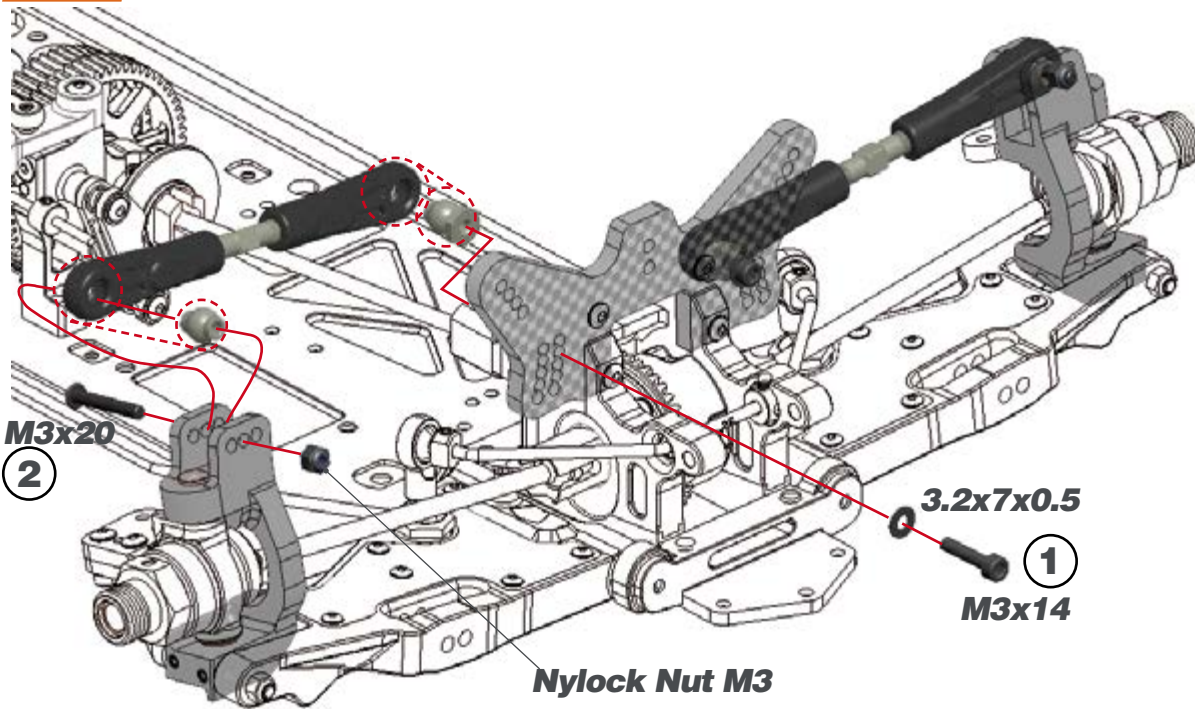





**STEP 33**

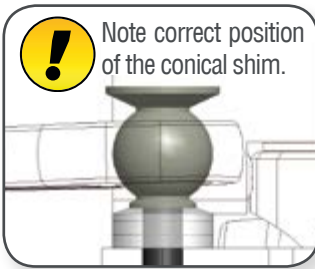
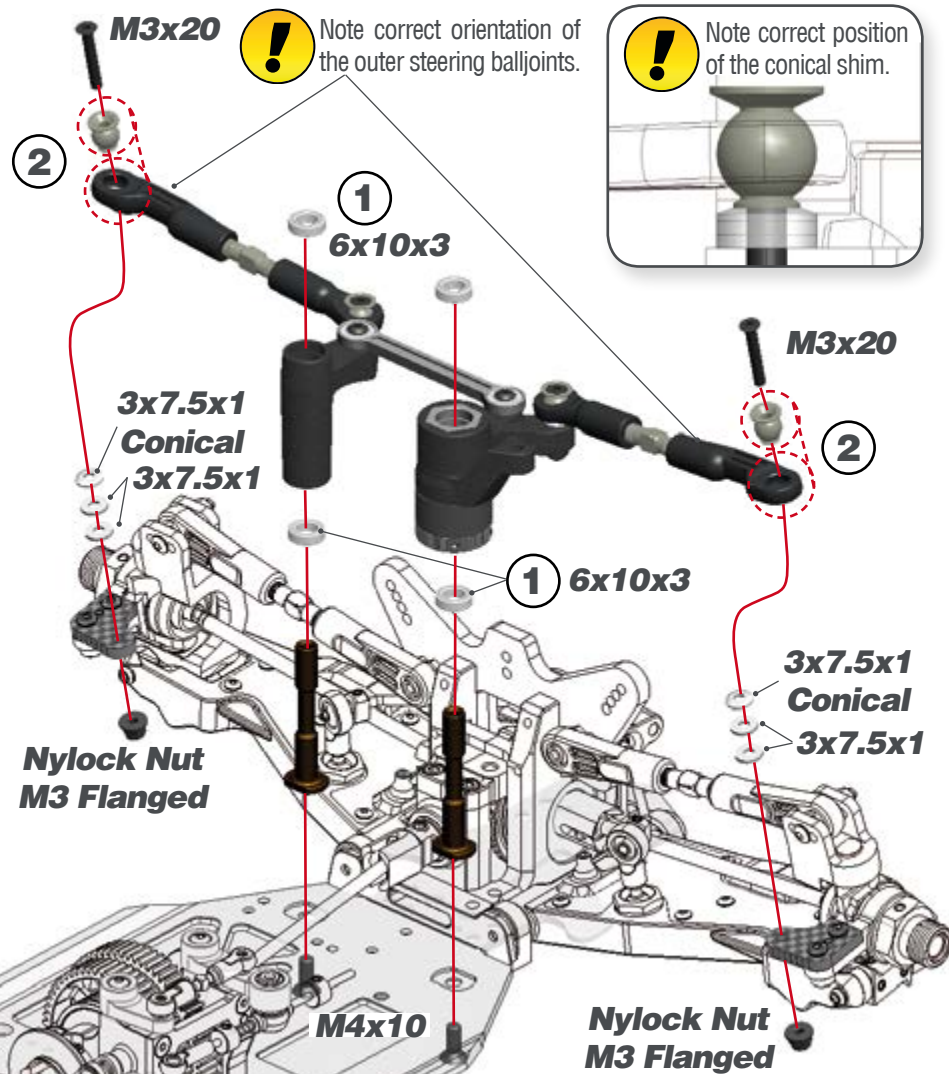

**STEP 34** **BAG 10**

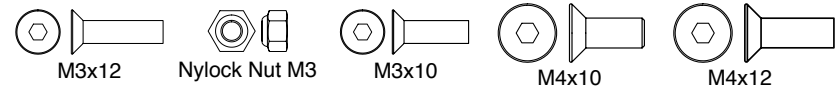
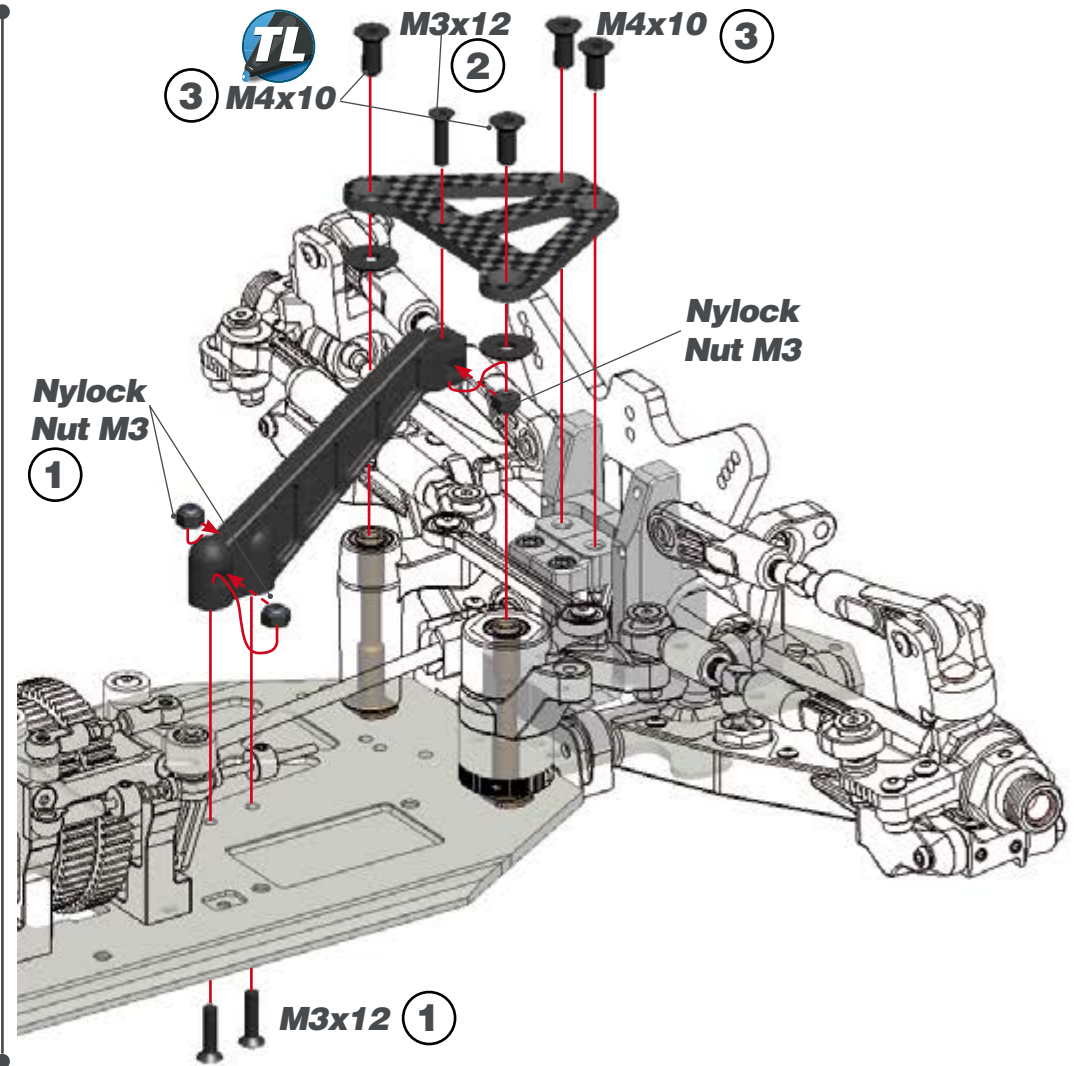

**STEP 35**

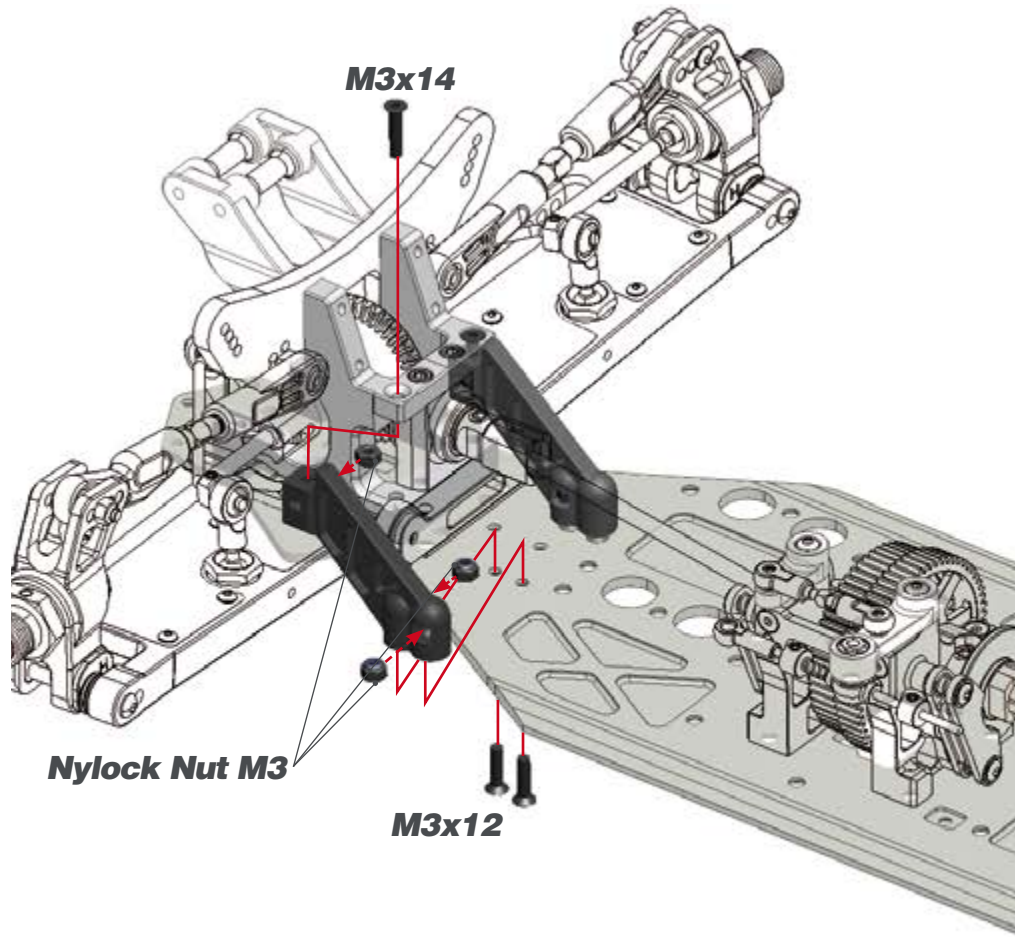

**M3x14**

**Nylock Nut M3**

**M3x12**

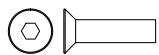

M3x12



Nylock Nut M3

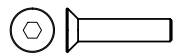

M3x14

**STEP 36**

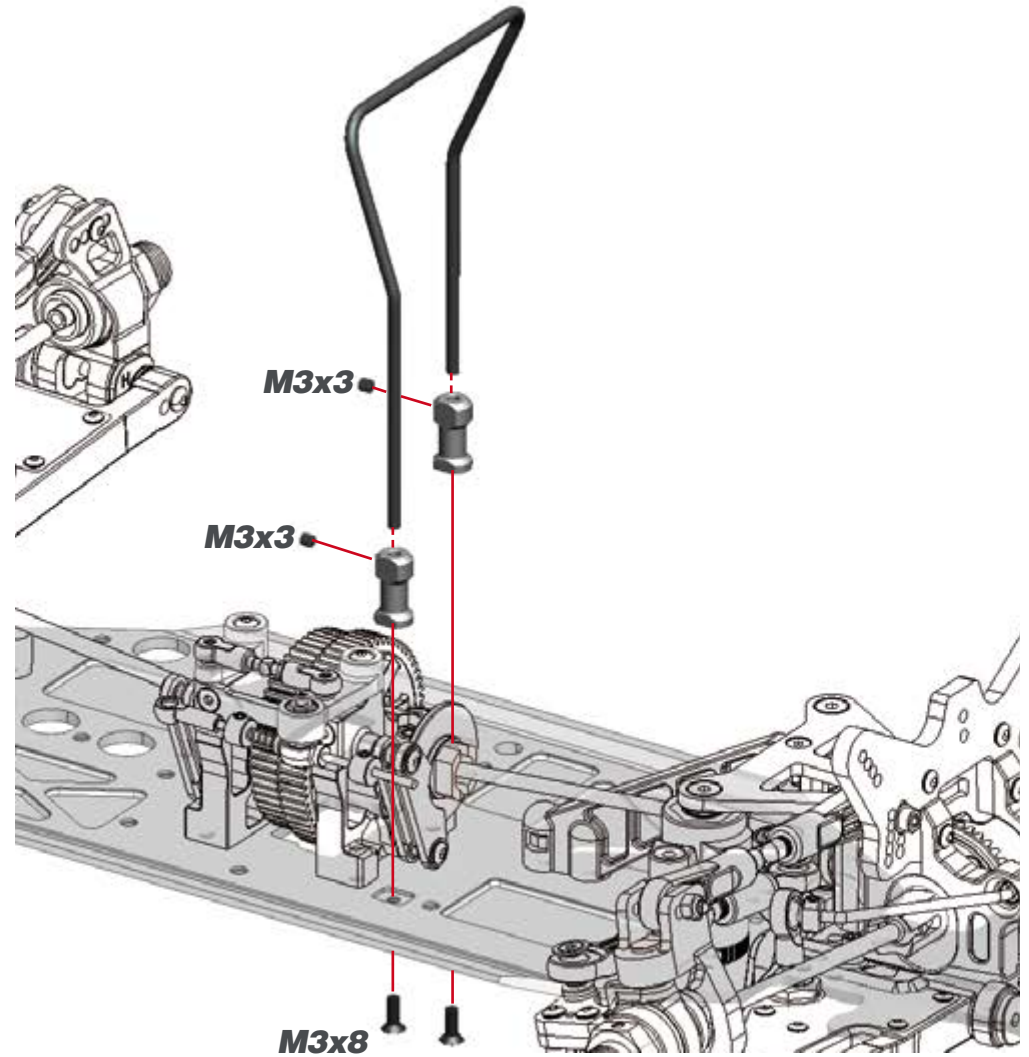

**M3x3**

**M3x3**

**M3x8**



M3x3



M3x8



## STEP 37

BAG 11

### 37.1



Push the long leg of the spring in the inner hole of the clutch shoe.

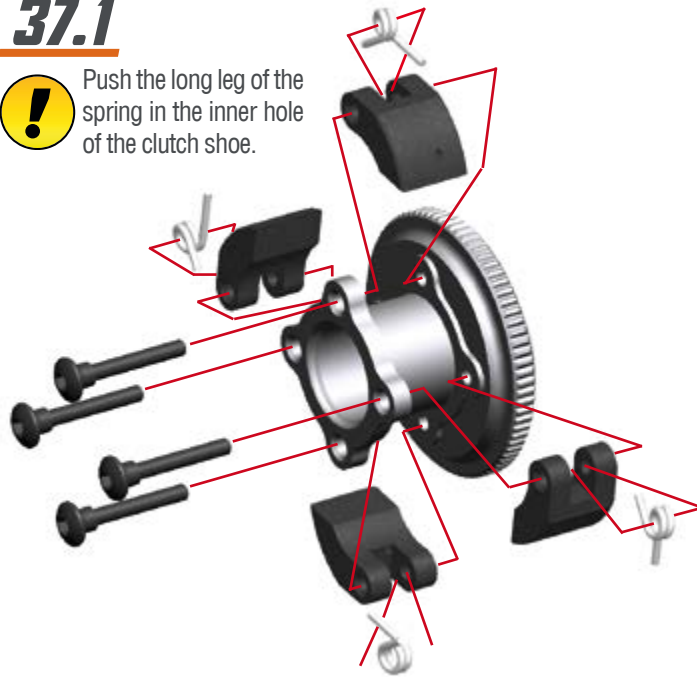

### 37.2

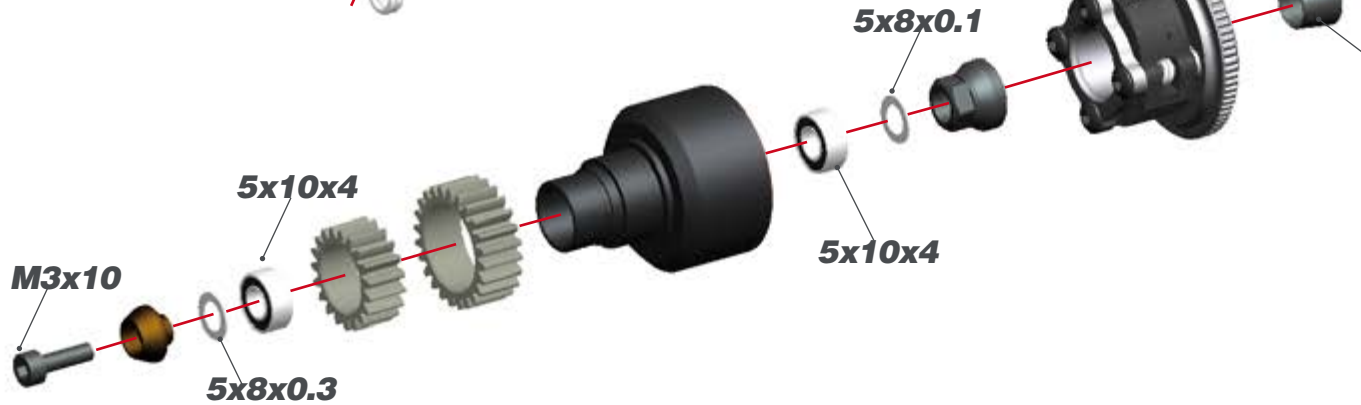

5x8x0.1

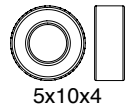

5x10x4



5x8x0.3

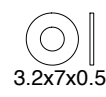

3.2x7x0.5

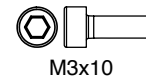

M3x10

**STEP 38**

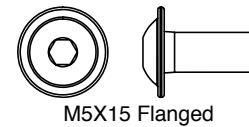
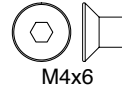
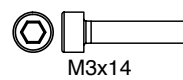
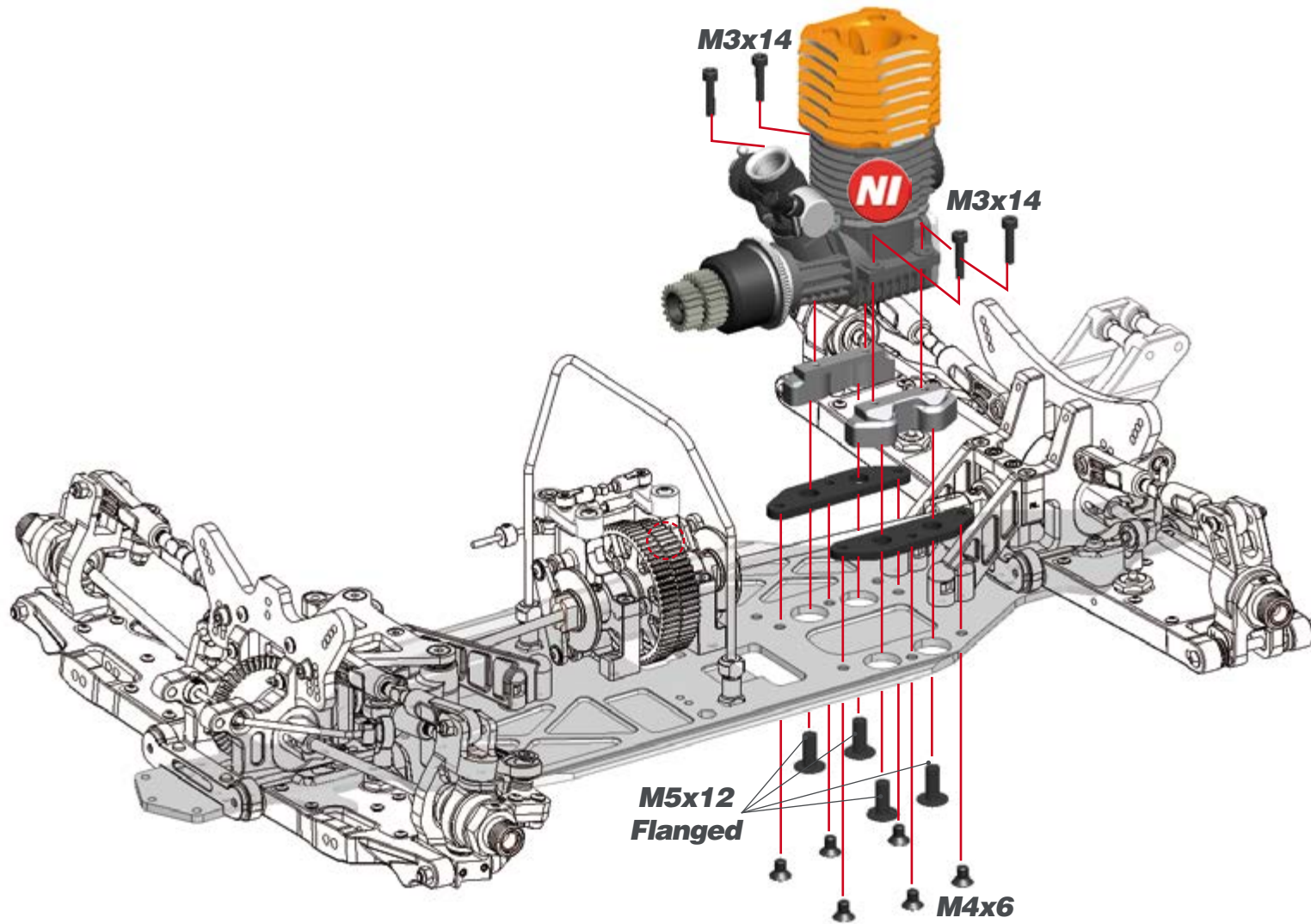

## STEP 39

BAG 12

## STEP 40

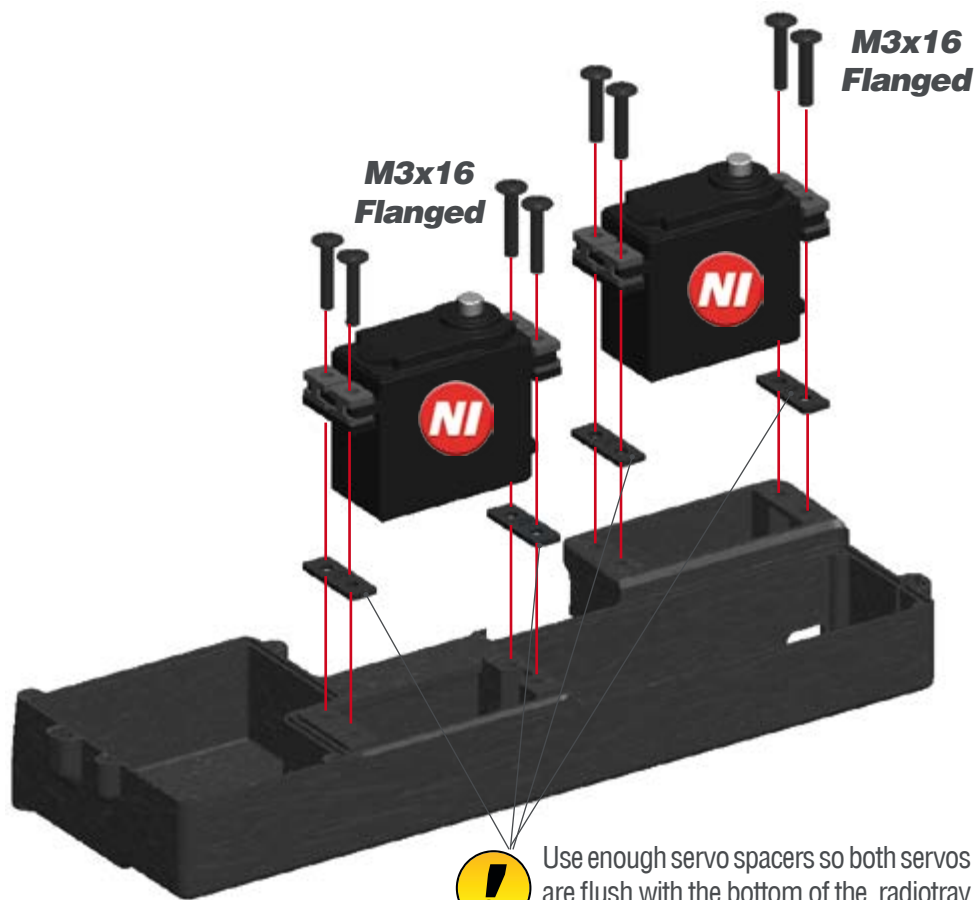

M3x16  
Flanged

M3x16  
Flanged



Use enough servo spacers so both servos are flush with the bottom of the radiotray posts. This will prevent the servo to touch the chassis under torsion – flex.

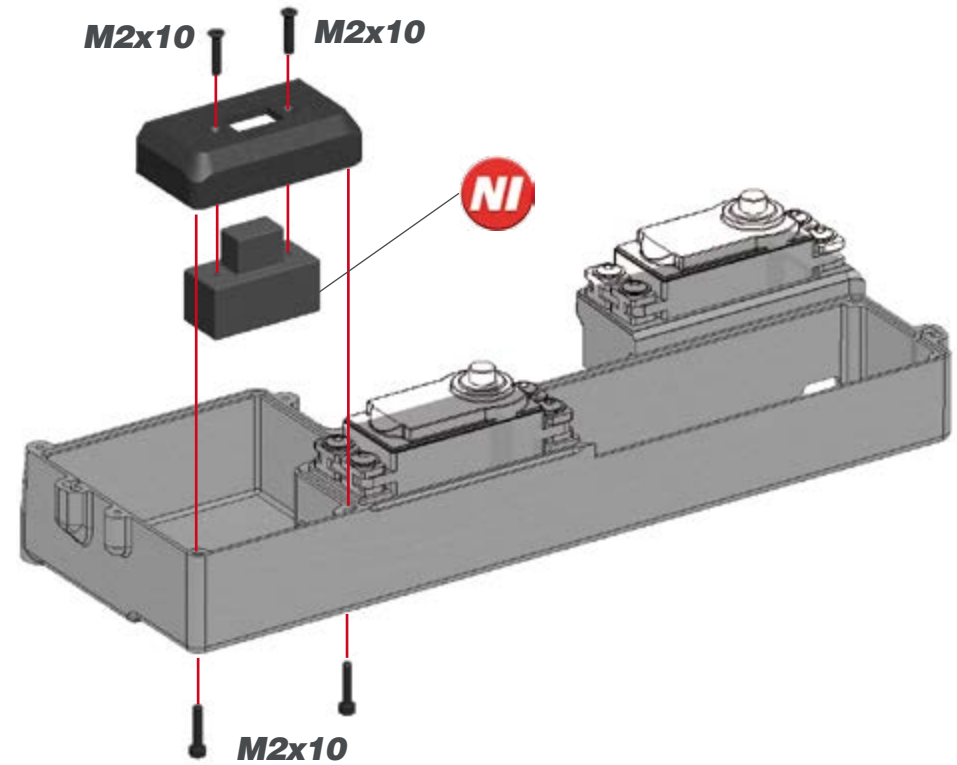

M2x10

M2x10

NI

M2x10

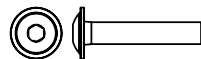

M3x16 Flanged

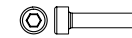

M2x10



M2x10



**STEP 41**

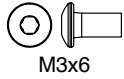
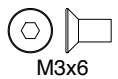
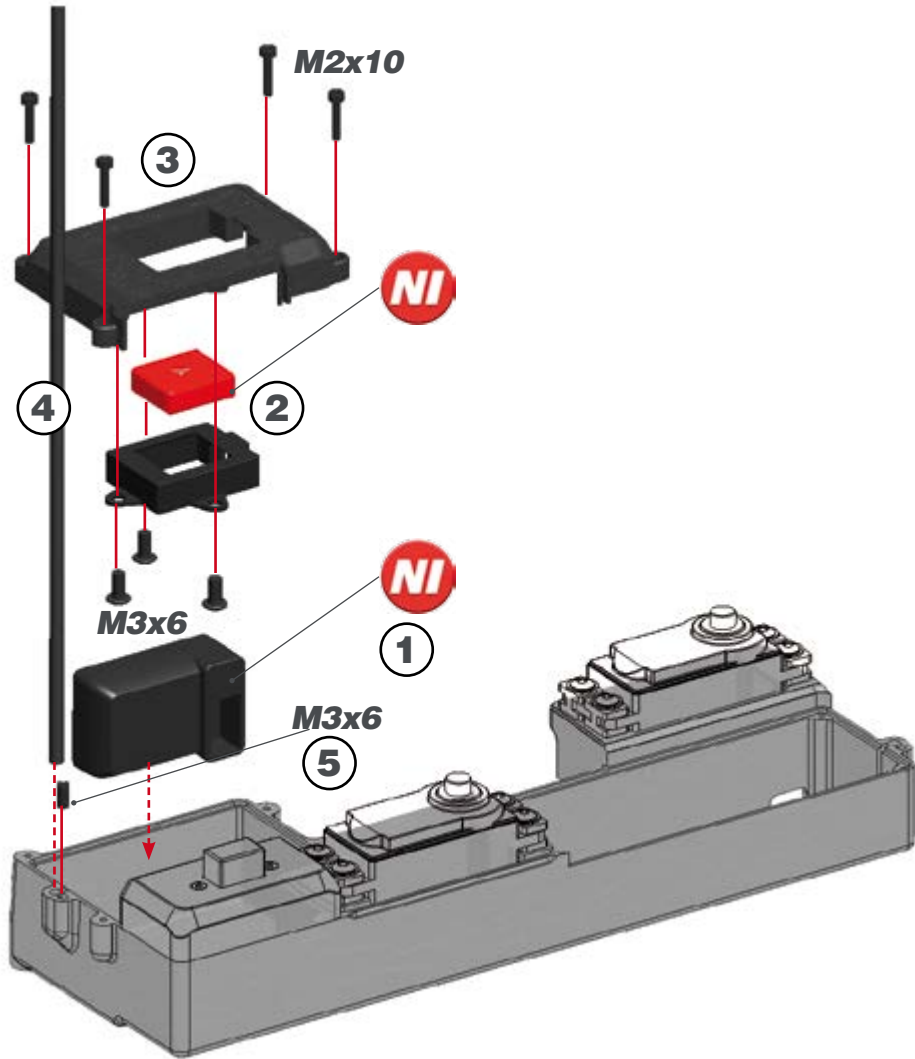

**STEP 42**

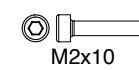
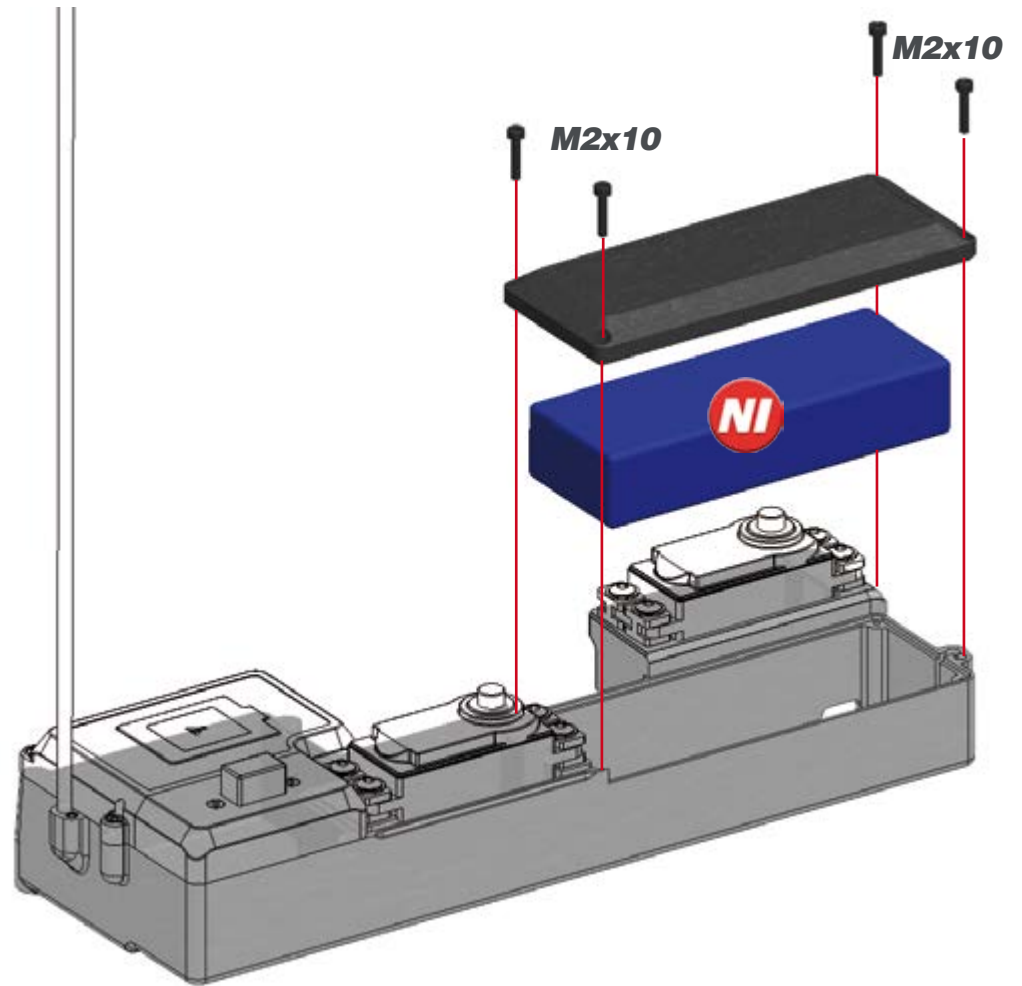

**STEP 43**

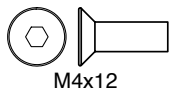
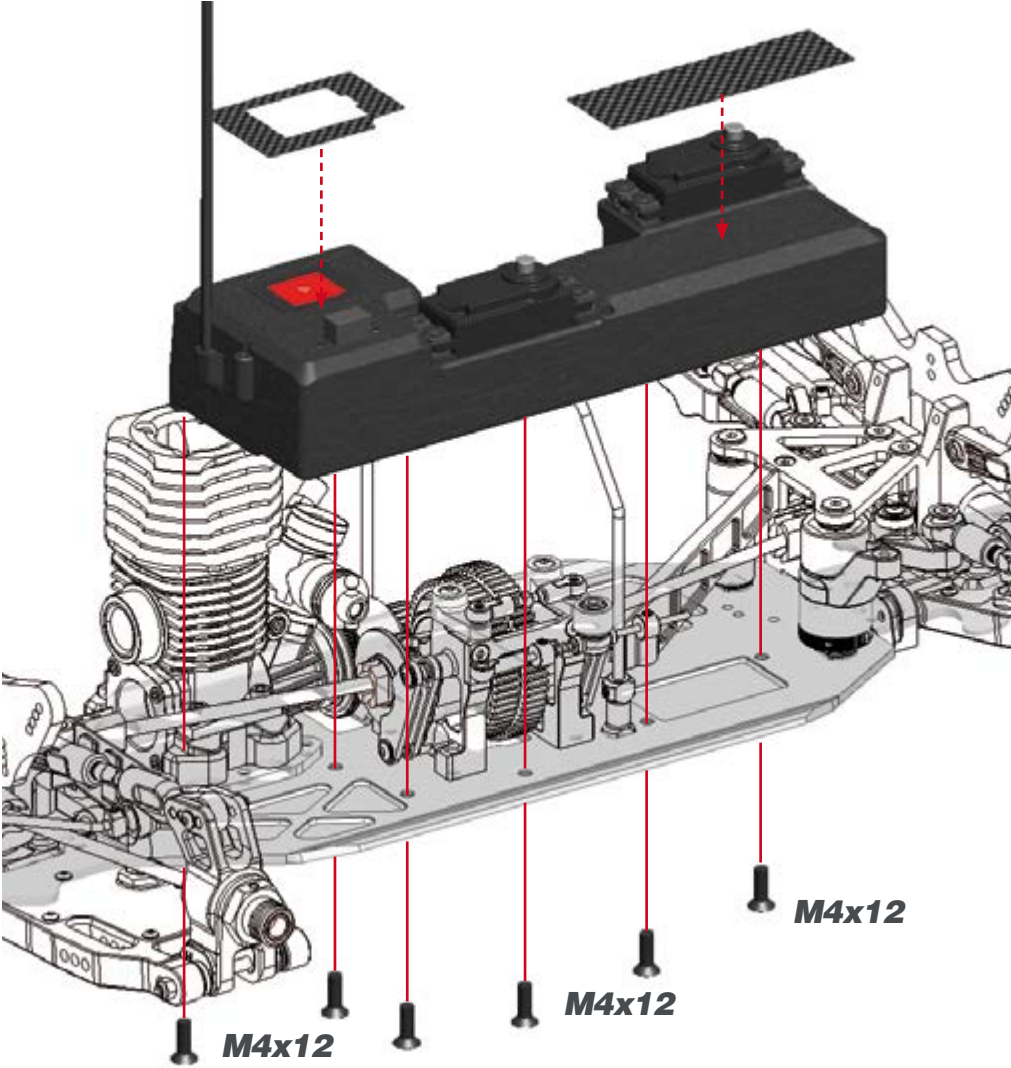

**STEP 44**



**STEERING LINK LENGTH**  
Between different servo brands there could be slight differences.

19.3 - 19.6 mm

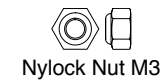
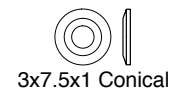
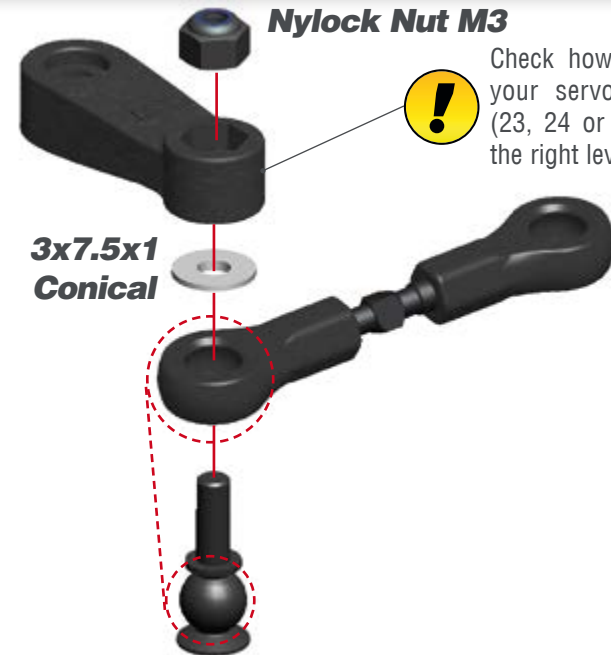

**STEP 45**

**45.1**

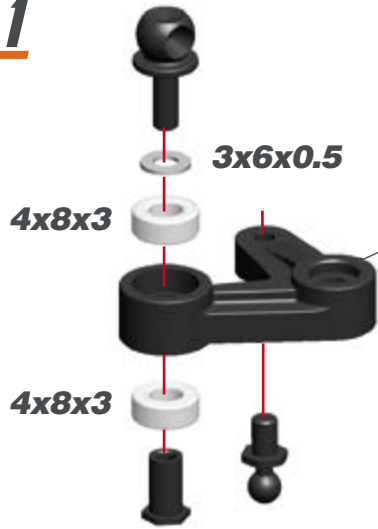

Check how many teeth your servo spline has (23, 24 or 25) and use the right lever.

**45.2**

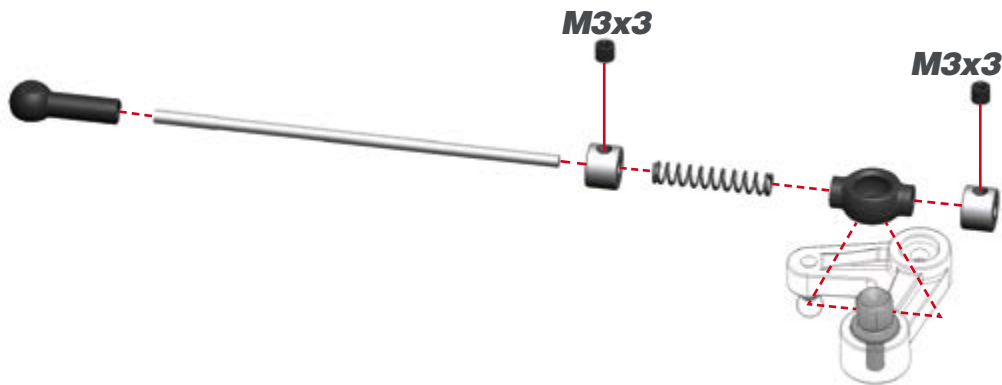

**STEP 46**

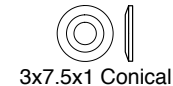
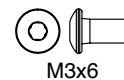
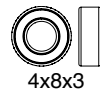
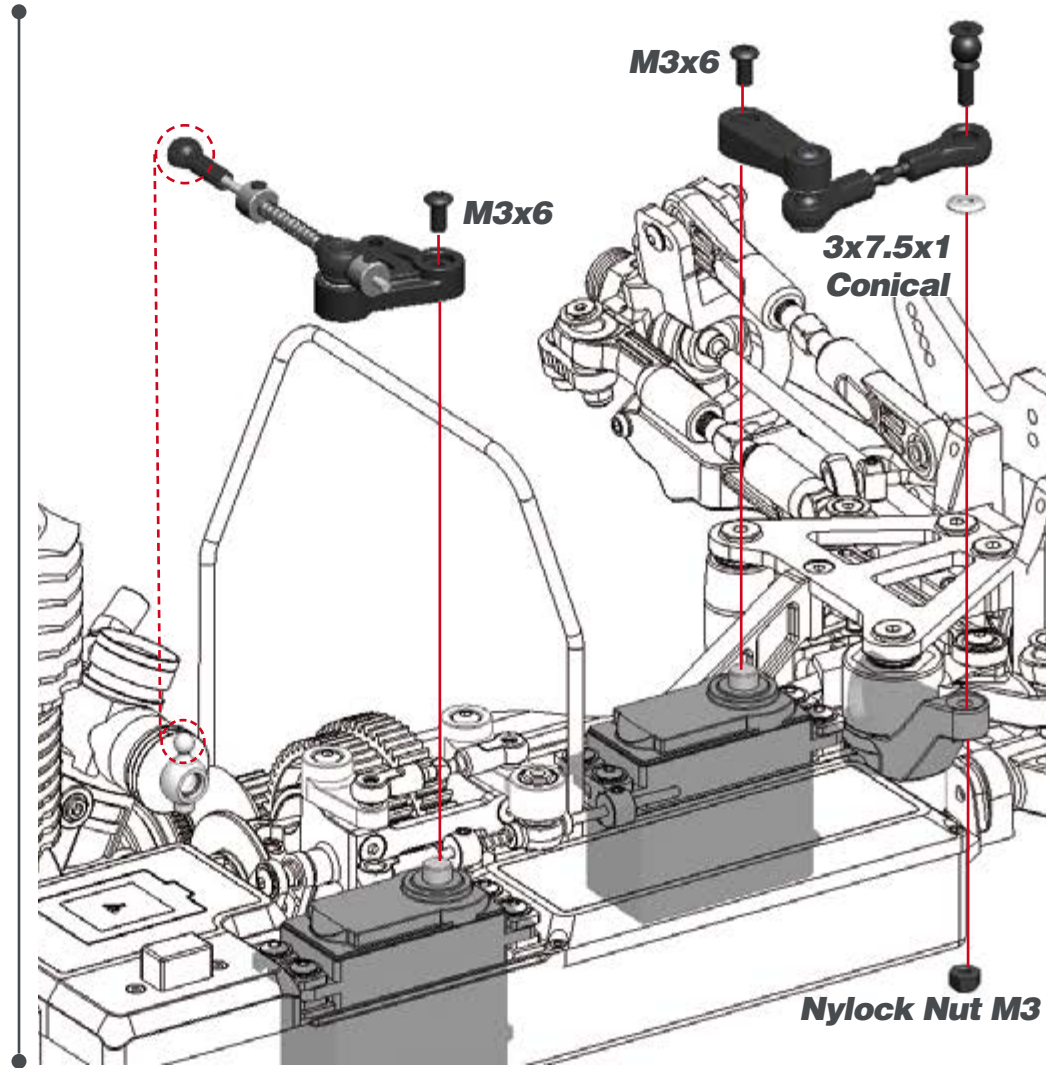



## STEP 47 SHOCK BAG

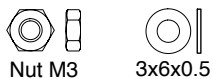
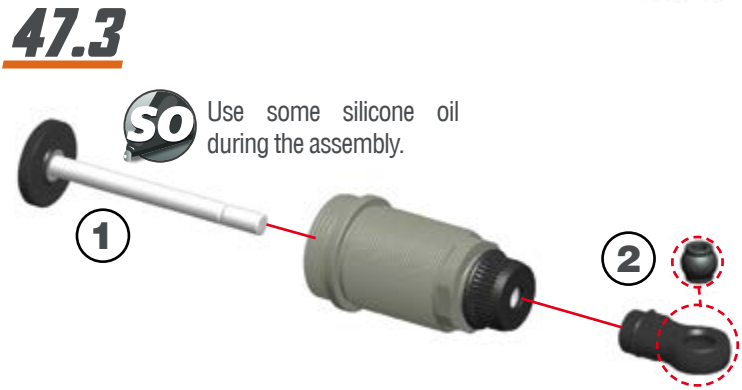
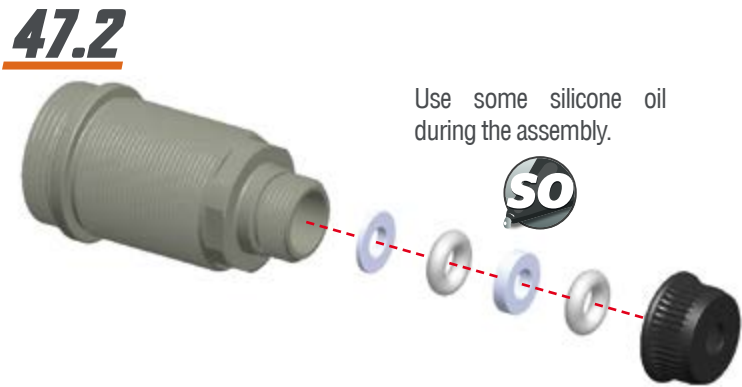

## STEP 48

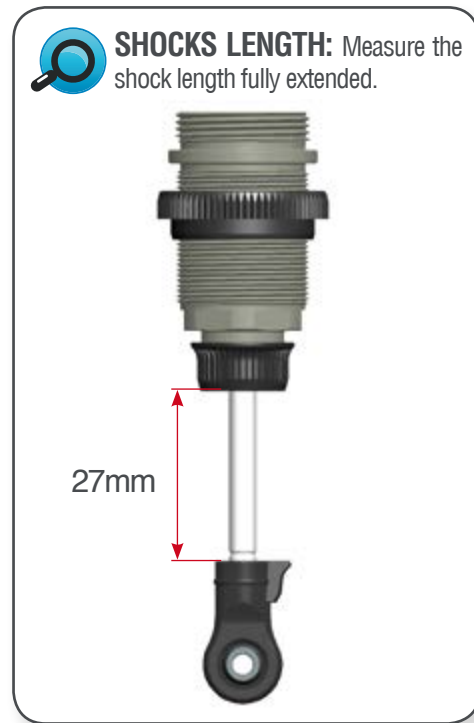
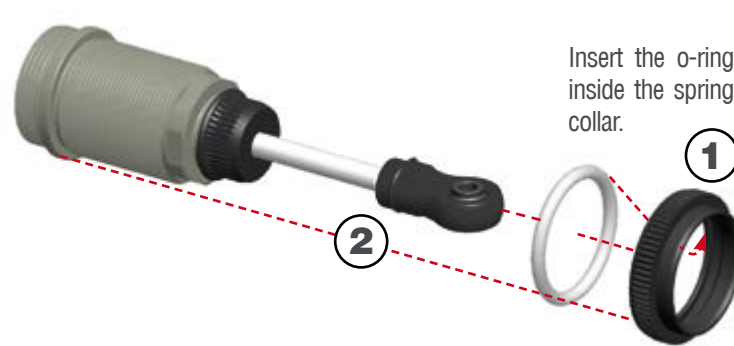

## STEP 49

- 1- Fill up with silicone oil fully using the silicone oil supplied in the kit. For the correct cst value please check the default setupsheet.
- 2- Extend the shockrod fully
- 3- Move the shockrod slowly up and down to let ALL air bubbles escape.



**STEP 50**

**50.1**

Push the membrane into the shock cap.



**50.2**

Close top step by step only 3/4



**STEP 51**

1-Bleed: push the shock-rod all the way in slowly, to allow excessive oil to escape.

2- With shockrod fully in, close fullu the shock cap.



**STEP 52**

Assemble the spring and spring-cup (align correctly) to complete the shock.

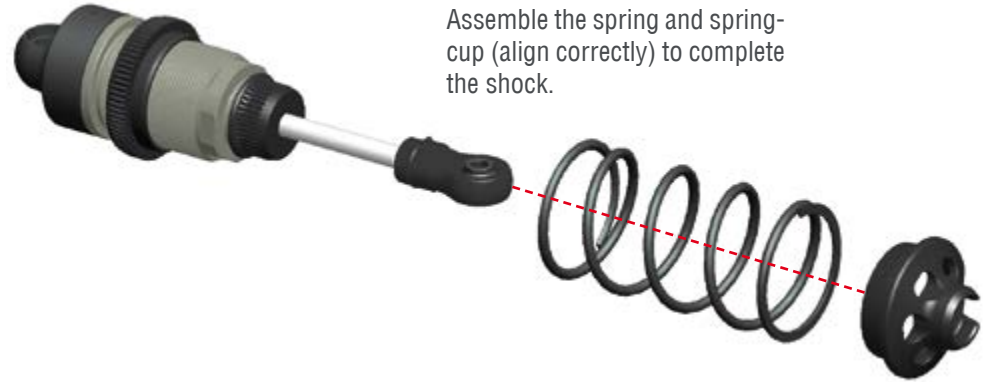

**STEP 53**

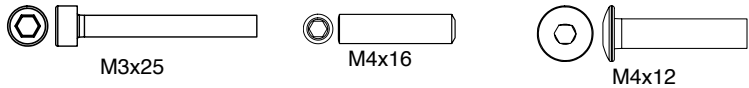
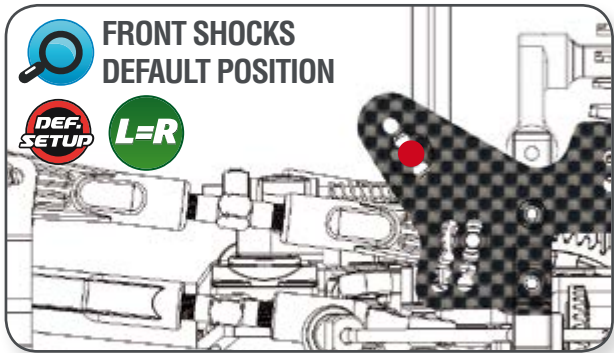
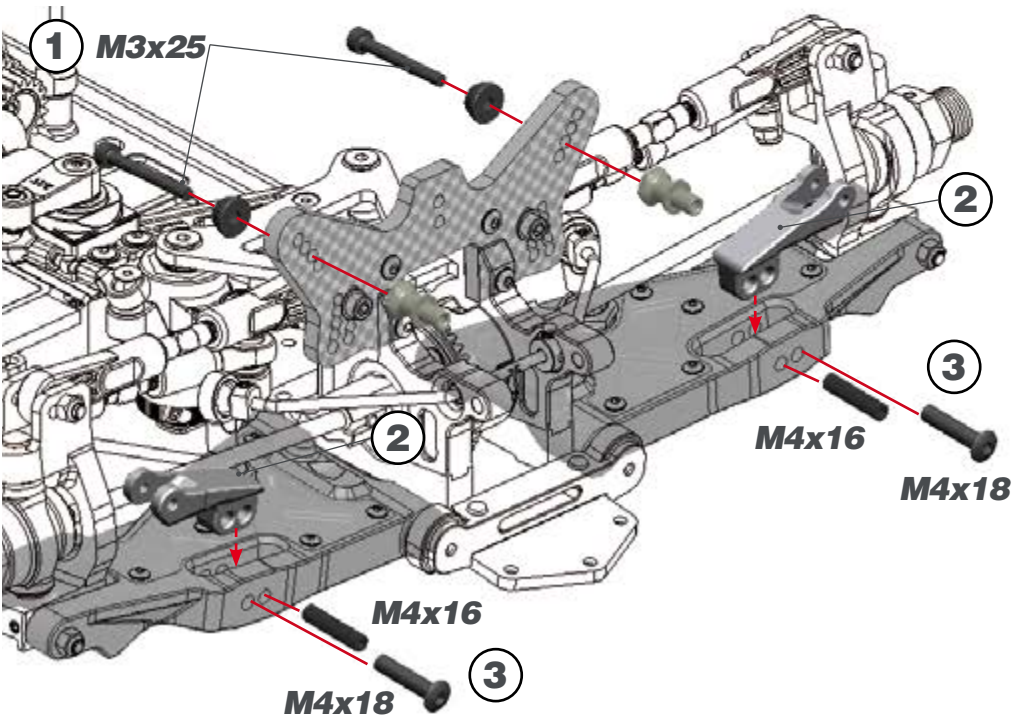

**STEP 54**

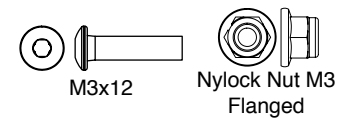
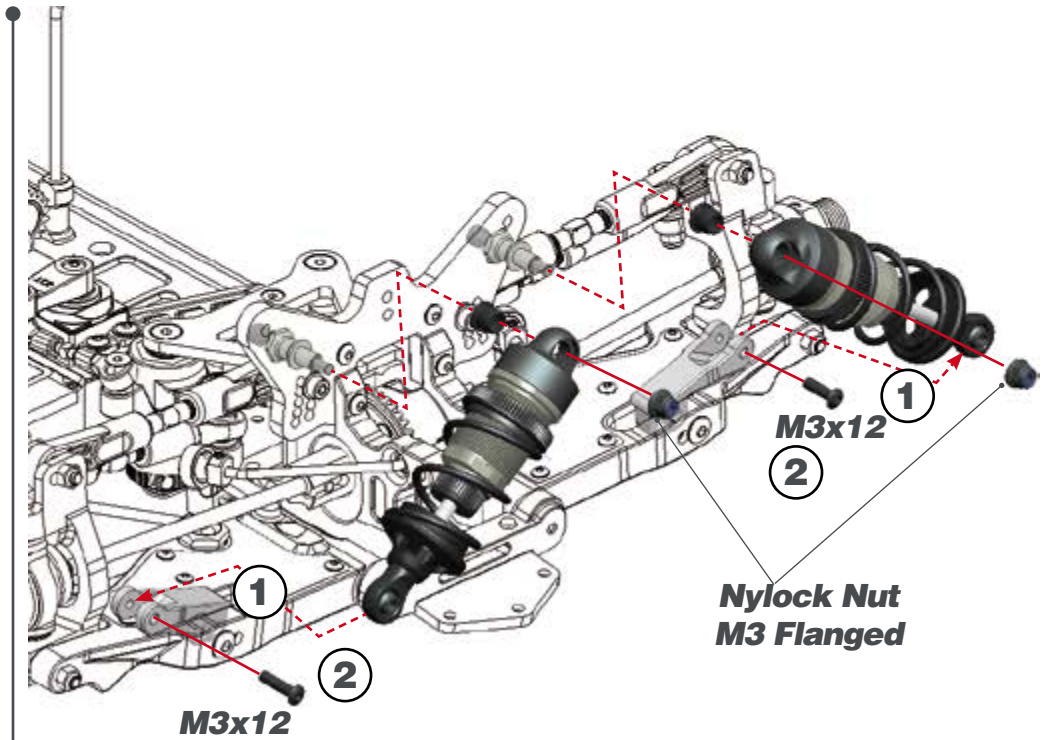



**STEP 55**

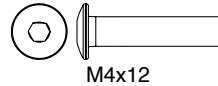
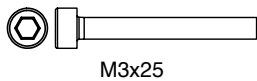
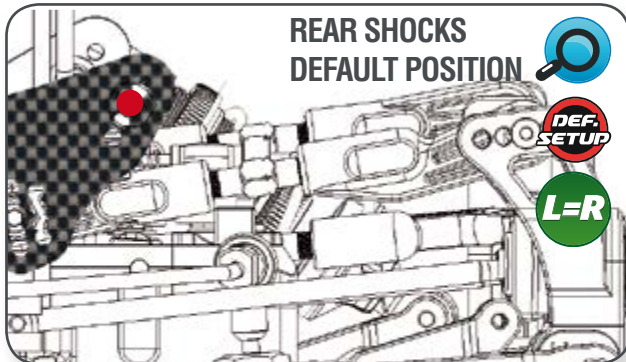
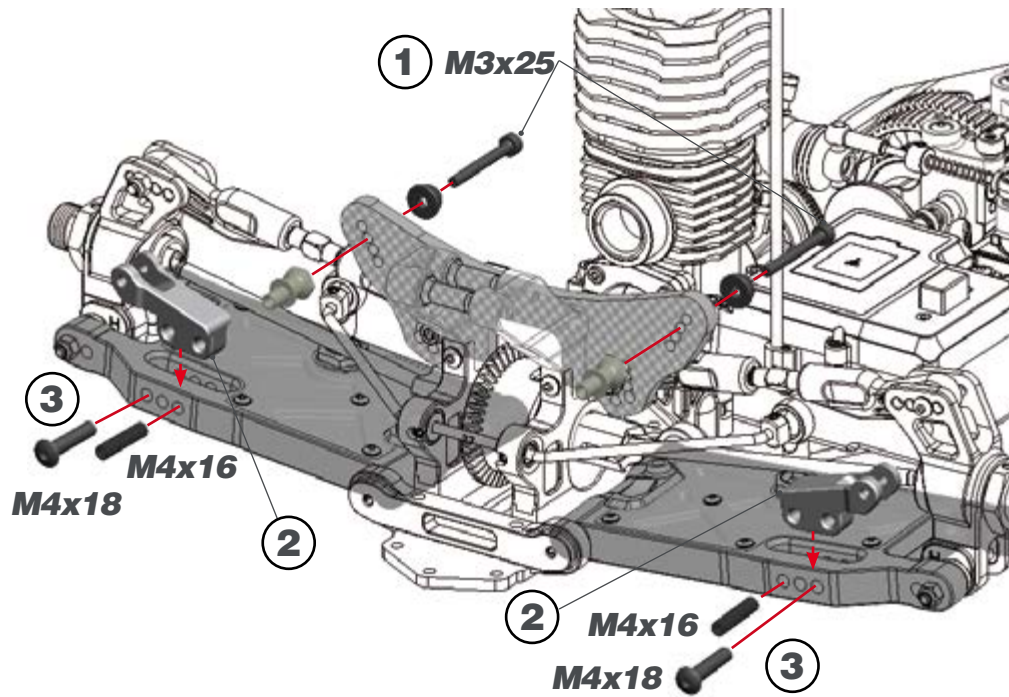

**STEP 56**

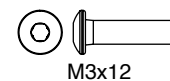
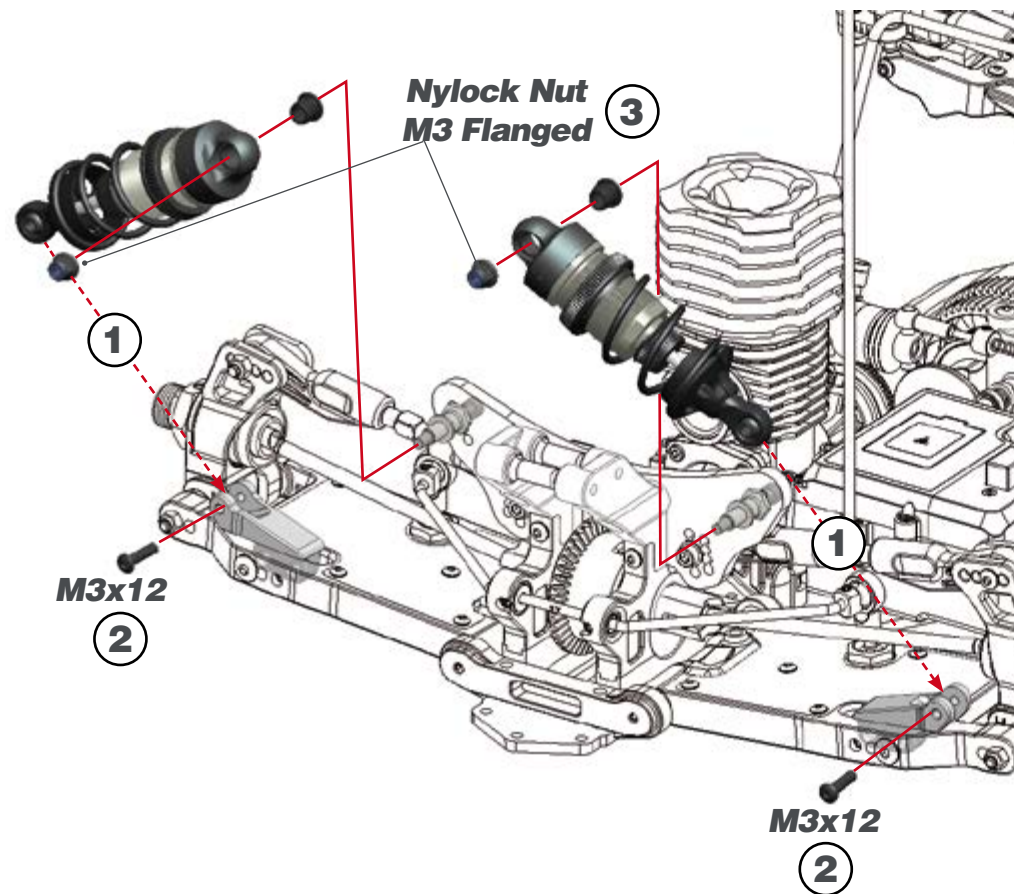

## STEP 57

BAG 13

### 57.1

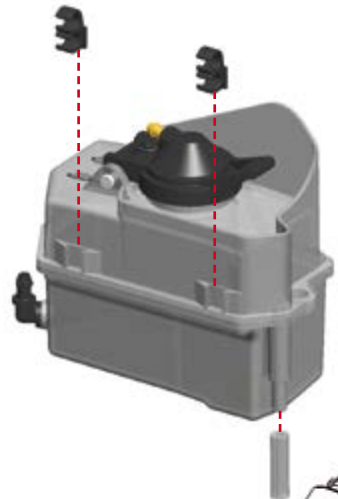

### 57.2

M3x12  
Flanged

M3x12  
Flanged

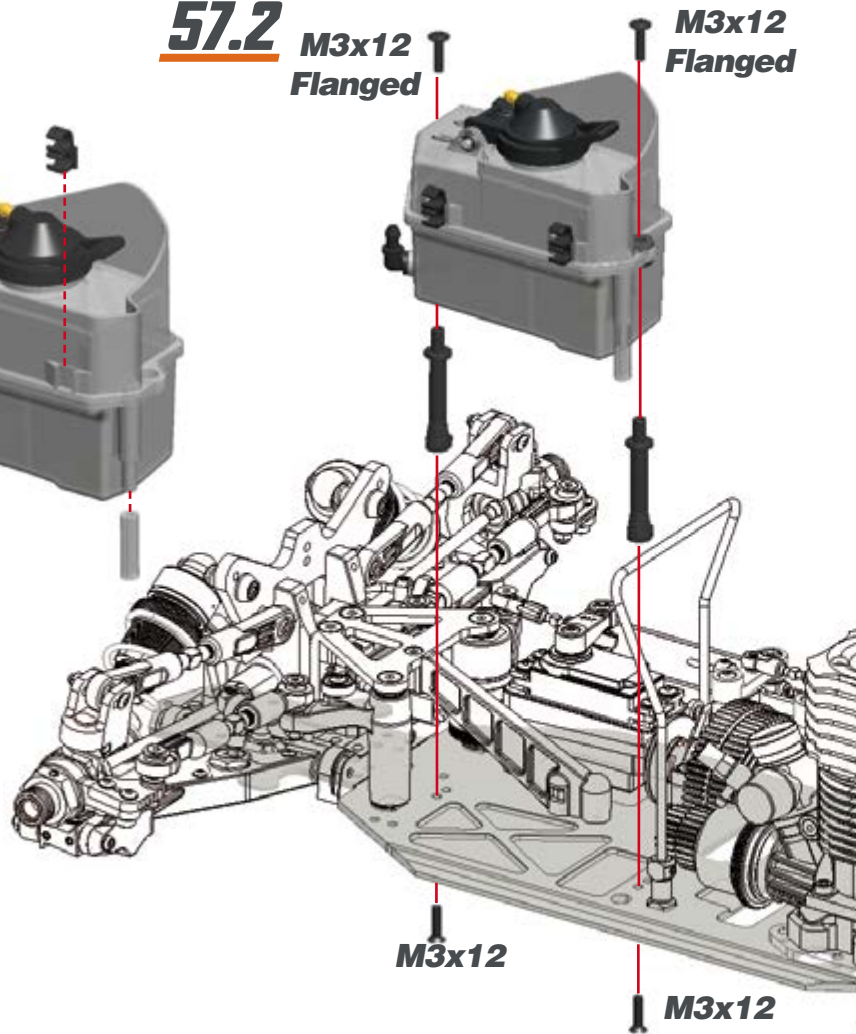

M3x12

M3x12



M3x12 Flanged

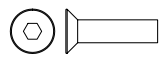

M3x12

## STEP 58

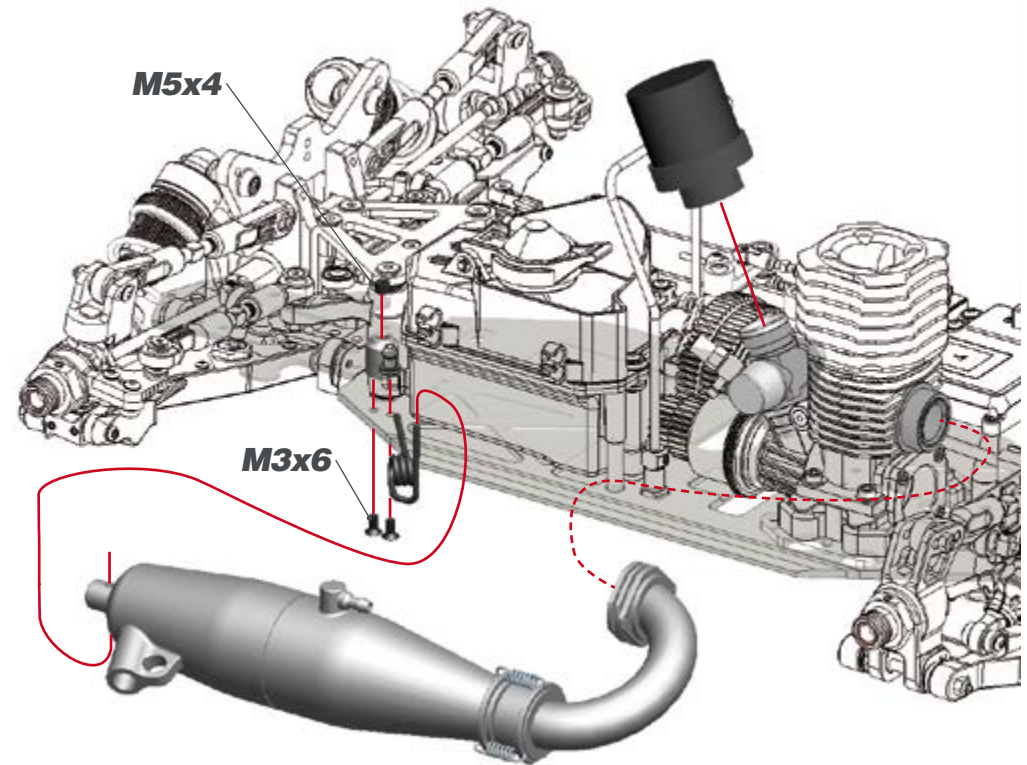

M5x4

M3x6



M3x6



M5x4



**STEP 59**

**BAG 14**

**STEP 60**

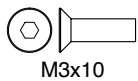
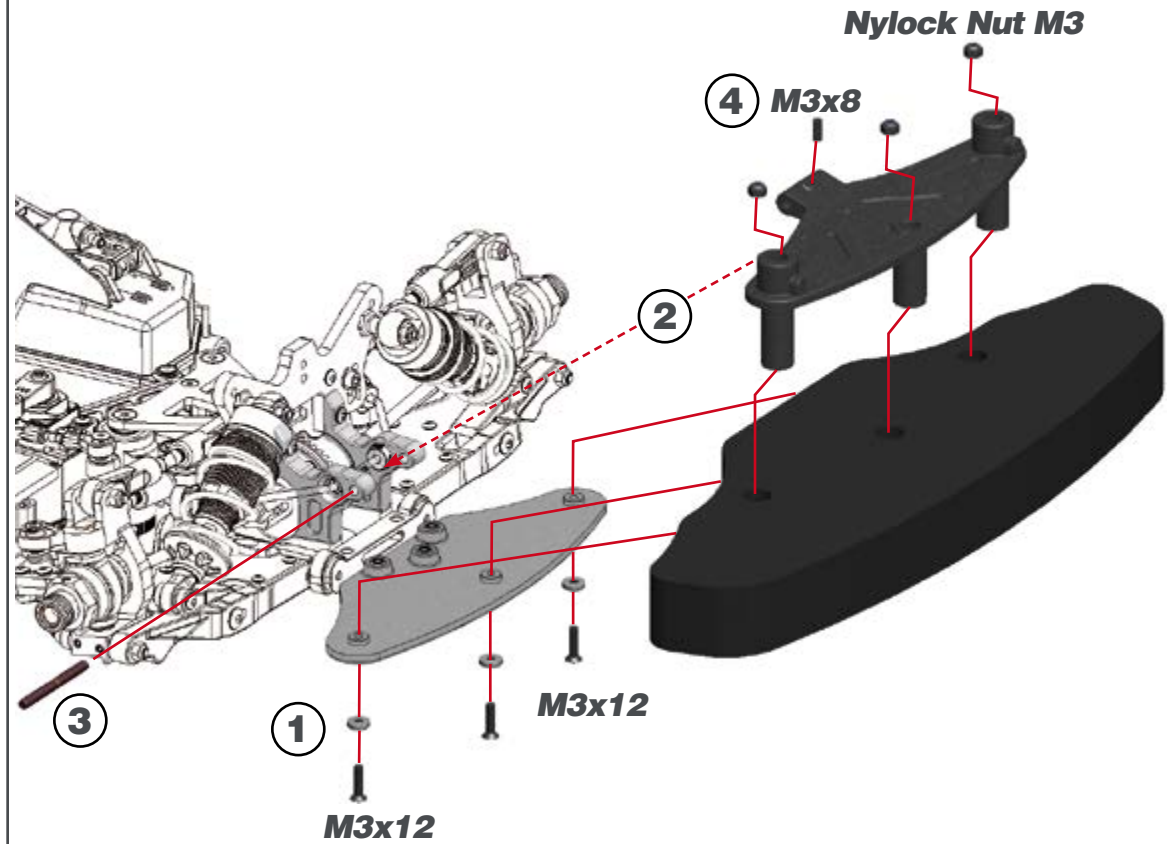
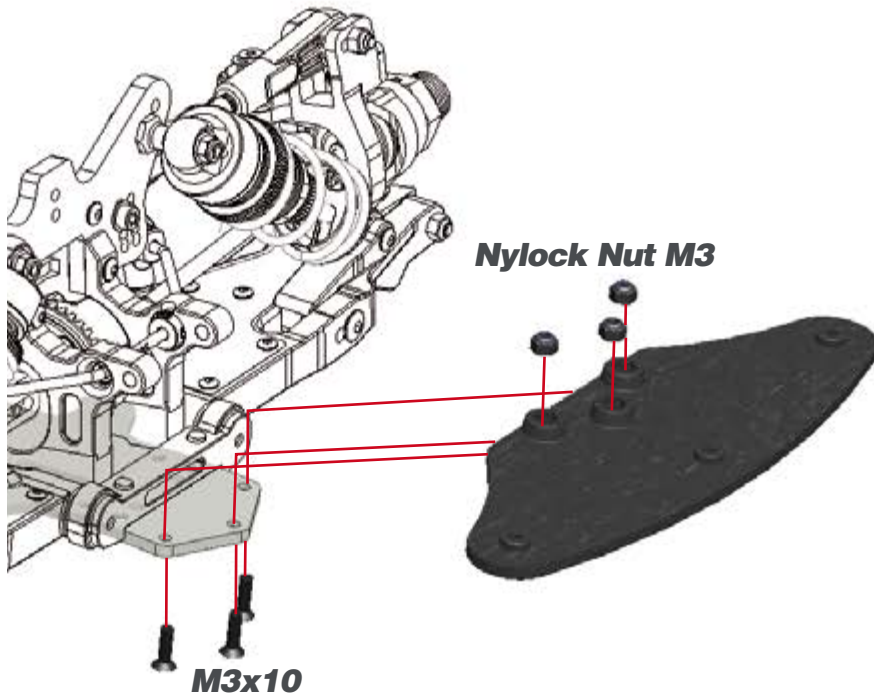

M3x10



Nylock Nut M3



M3x8



M3x12



Nylock Nut M3



**STEP 61**

**STEP 62** **BAG 15**

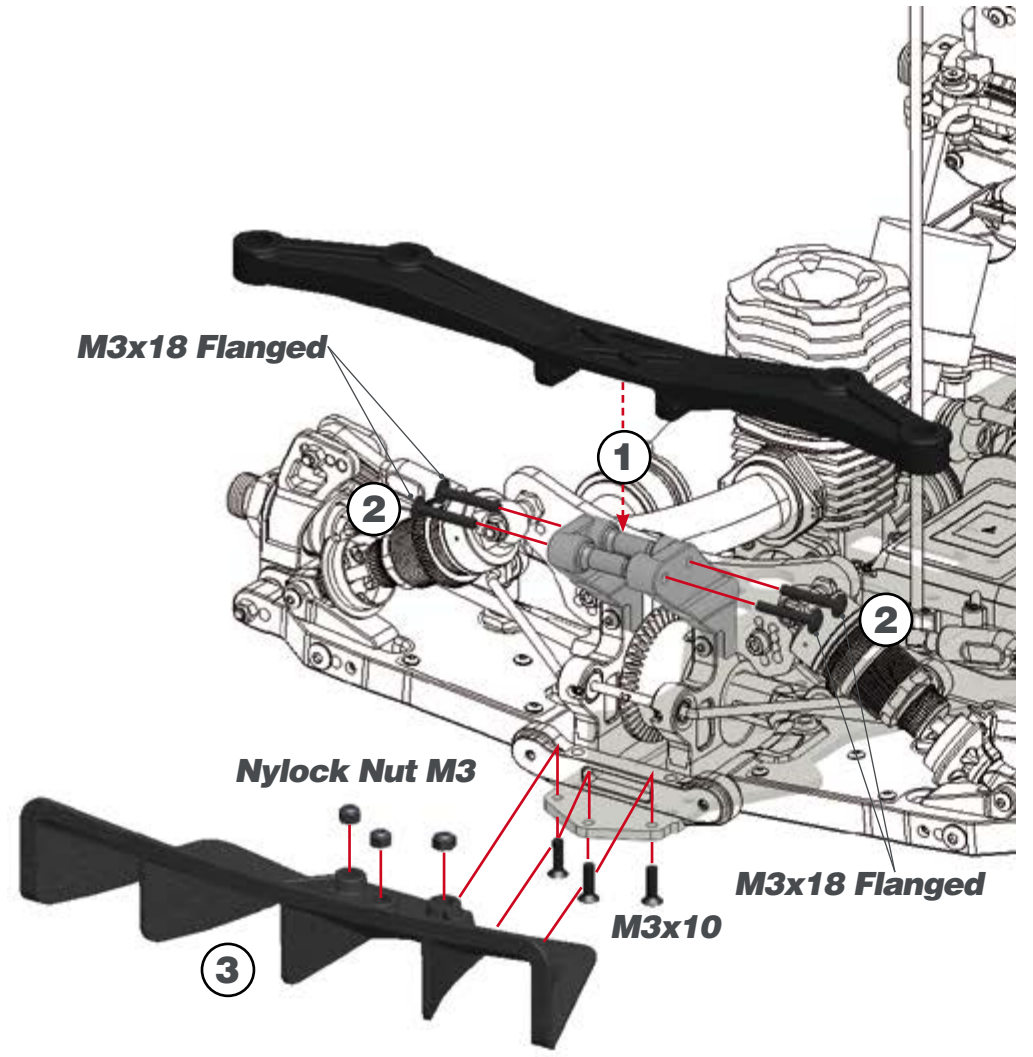
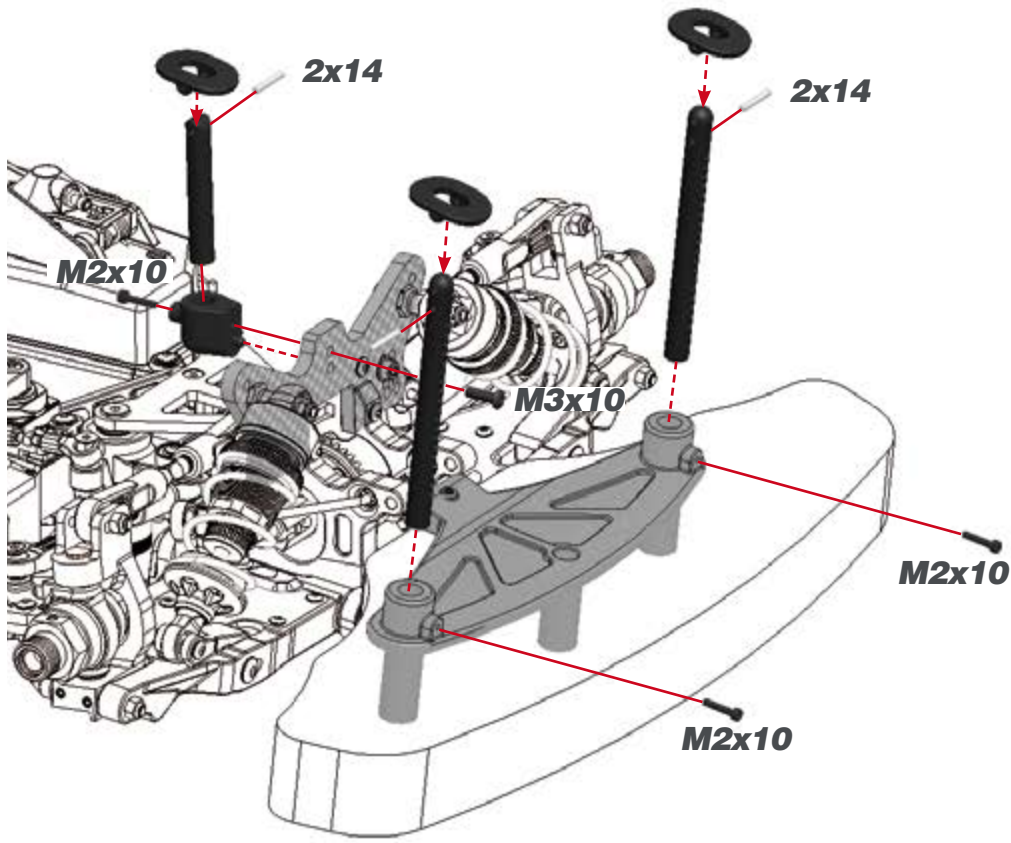

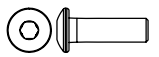
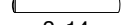
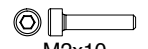
-   
M3x10
-   
2x14
-   
M2x10

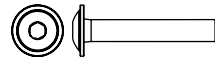
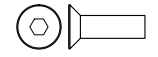
-   
Nylock Nut M3
-   
M3x18 Flanged
-   
M3x10

**STEP 63**

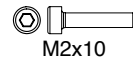
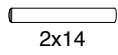
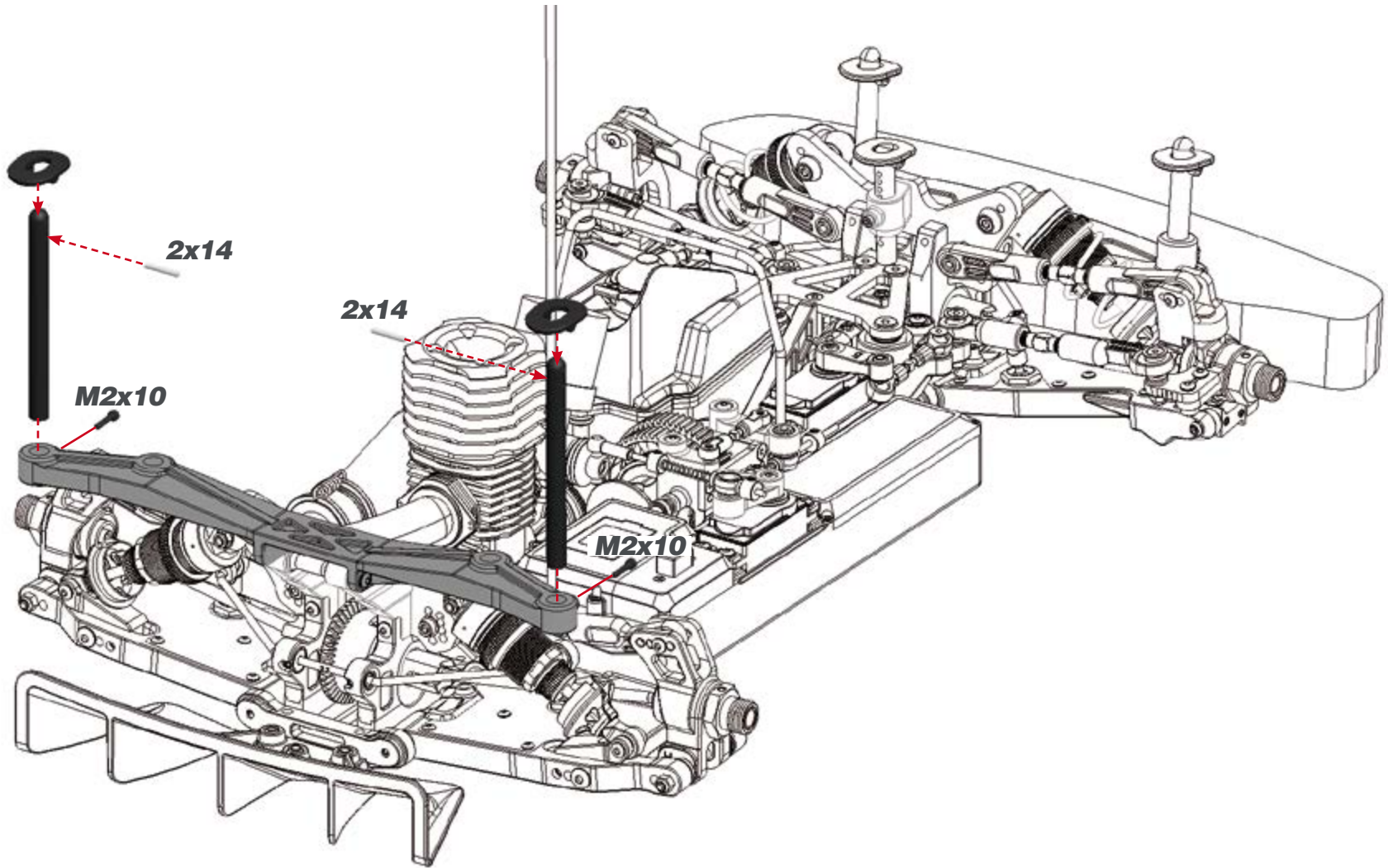

## INDEX

<b><i>DIFFERENTIALS EXPLODED VIEW</i></b>	<b>40</b>
<b><i>GEARBOX EXPLODED VIEW</i></b>	<b>41</b>
<b><i>MID EXPLODED VIEW</i></b>	<b>42</b>
<b><i>REAR EXPLODED VIEW</i></b>	<b>43</b>
<b><i>FRONT EXPLODED VIEW</i></b>	<b>44</b>
<b><i>STEERING EXPLODED VIEW</i></b>	<b>45</b>
<b><i>RADIO EXPLODED VIEW</i></b>	<b>46</b>
<b><i>SHOCKS EXPLODED VIEW</i></b>	<b>47</b>
<b><i>CLUTCH EXPLODED VIEW</i></b>	<b>48</b>
<b><i>FINAL 1 EXPLODED VIEW</i></b>	<b>49</b>
<b><i>FINAL 2 EXPLODED VIEW</i></b>	<b>50</b>



# DIFFERENTIAL EXPLODED VIEW

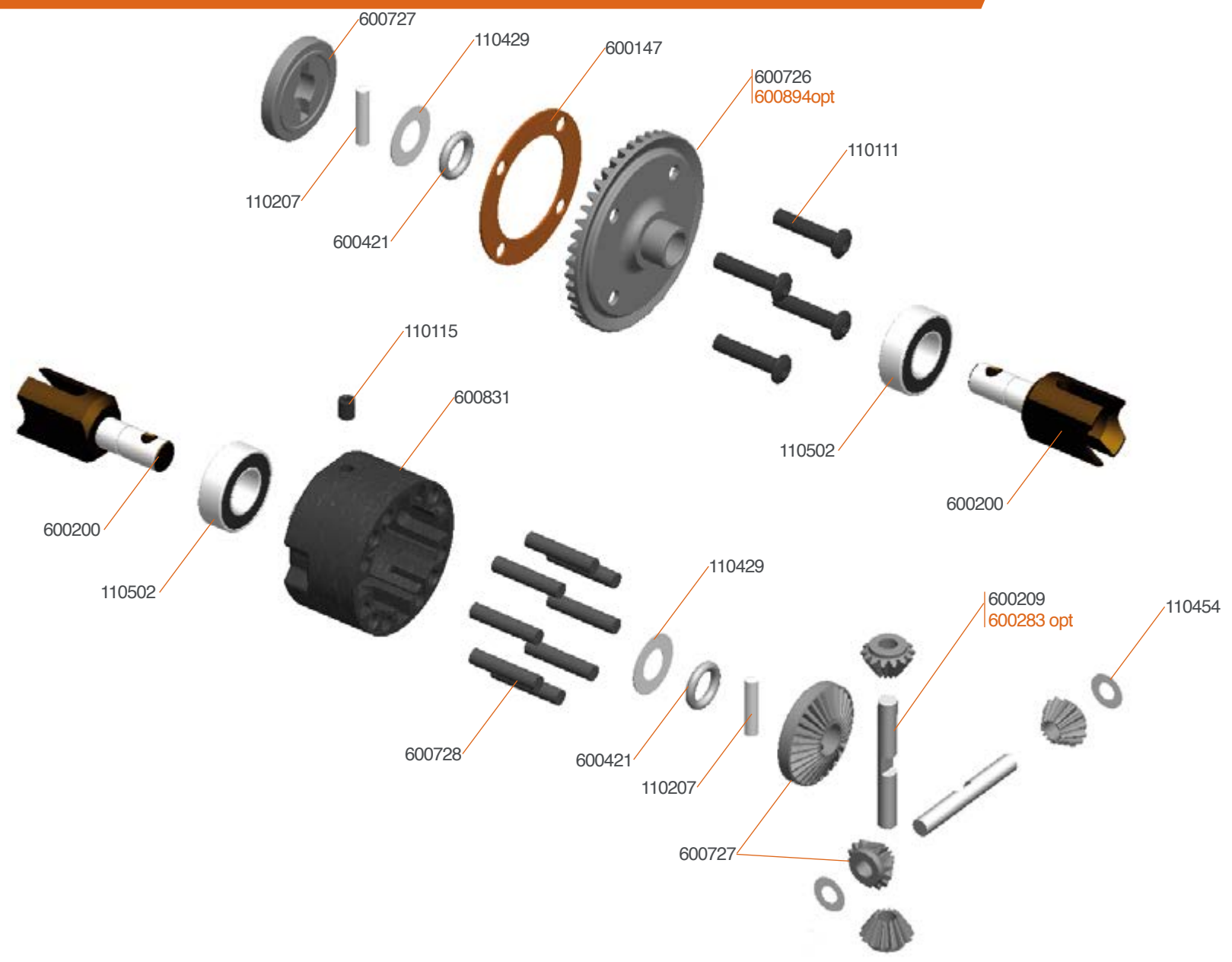

- 600894 Overdrive diff gear 43T SRX8
- 600868 Diff set 44T front / rear SRX8
- 600283 Diff pin 10T alu (2)

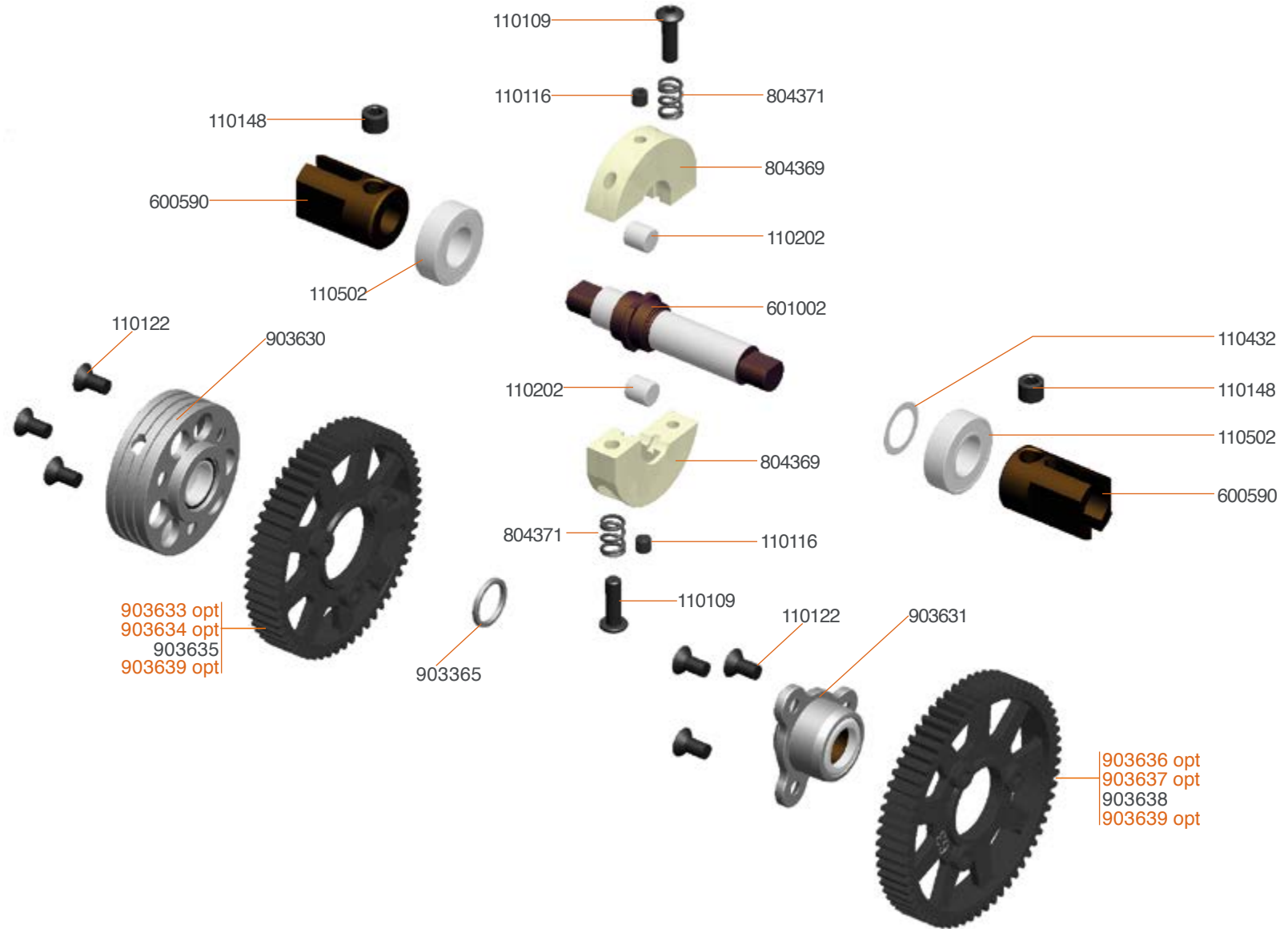

903633 2-speed gear 56T SL8 XLI  
 903634 2-speed gear 57T SL8 XLI  
 903636 2-speed gear 61T SL8 XLI  
 903637 2-speed gear 62T SL8 XLI

903639 2-speed gear set SL8 (6) XLI

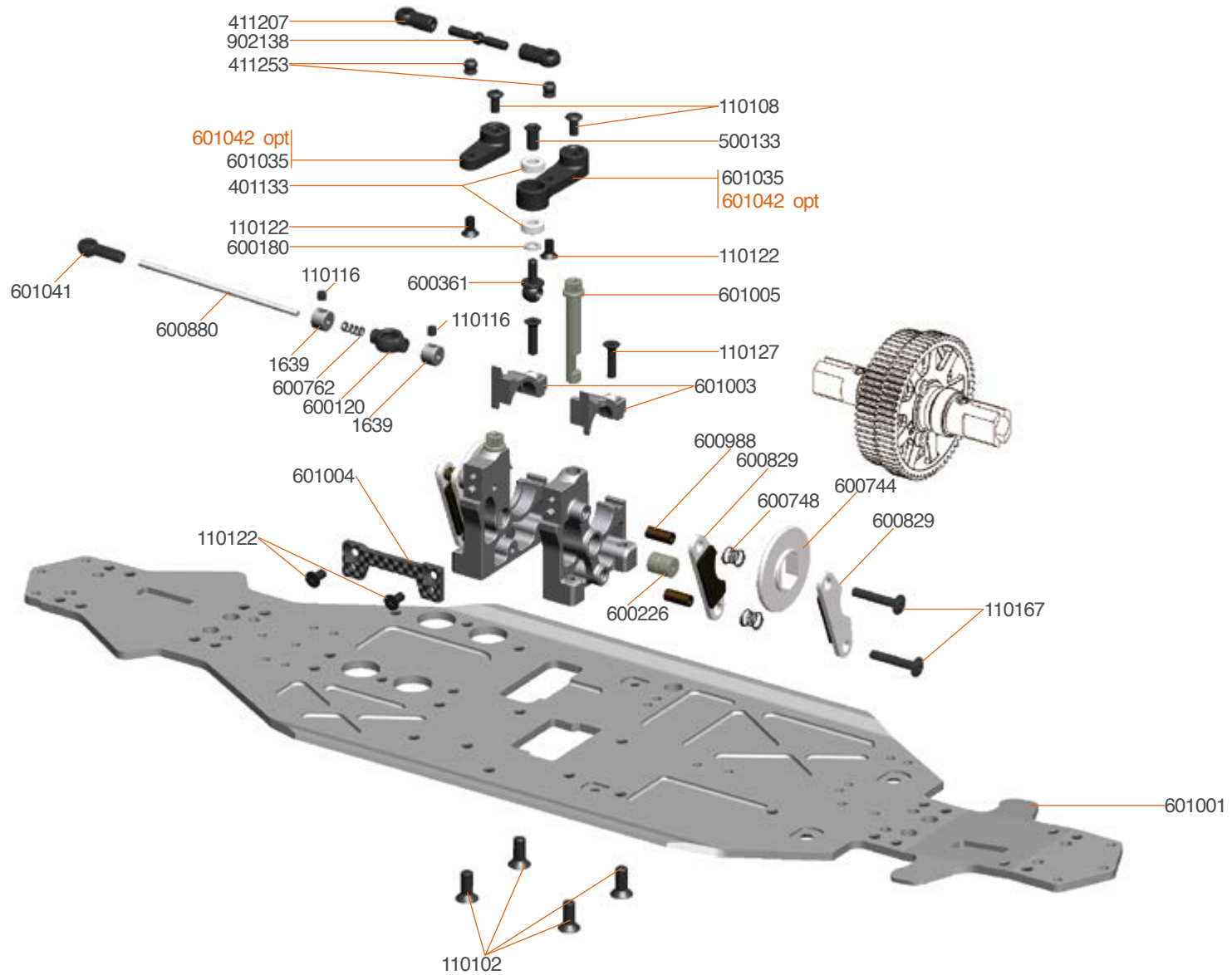

601042 Brake lever fr / rr alu SRX8 GT





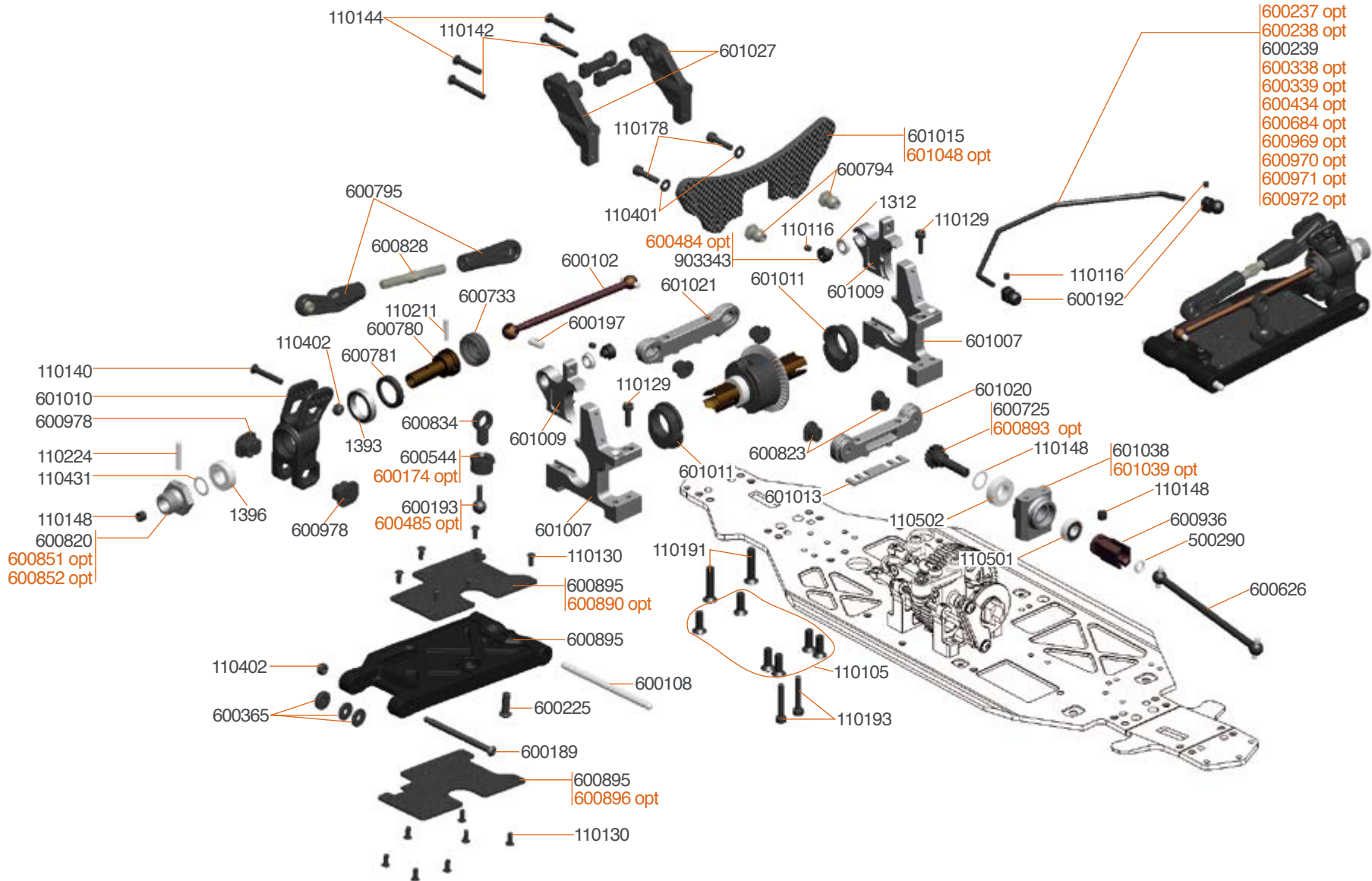

- 600237 opt
- 600238 opt
- 600239
- 600338 opt
- 600339 opt
- 600434 opt
- 600684 opt
- 600969 opt
- 600970 opt
- 600971 opt
- 600972 opt

- 110140
- 601010
- 600978
- 110224
- 110431
- 110148
- 600820
- 600851 opt
- 600852 opt

- 110402
- 600365

- 600174 Antirollbar nut (2)
- 600338 Antiroll bar rear 1.8mm
- 600339 Antiroll bar rear 2.0mm
- 600434 Antiroll bar rear 2.4mm
- 600237 Antiroll bar rear 2.3mm
- 600238 Antiroll bar rear 2.5mm
- 600684 Antiroll bar rear 3.0mm
- 600484 Antirollbar spacer 3mm alu (2)
- 600485 Pivotball threaded anti roll bar alu (2)
- 600896 Wishbone insert carbon RR Lower V2 SRX8
- 600851 Wheelhexagon 0mm light (2) SRX8
- 600852 Wheelhexagon +1mm light (2) SRX8
- 600890 Wishbone insert carbon RR Upper SRX8 (2)
- 600893 Overdrive diff pinion 13T SRX8

- 600969 Antiroll bar rear 2.2 mm
- 600970 Antiroll bar rear 2.4 mm
- 600971 Antiroll bar rear 2.6 mm
- 600972 Antiroll bar rear 2.8 mm
- 601048 Shock Tower RR Straight arm SRX8-GT



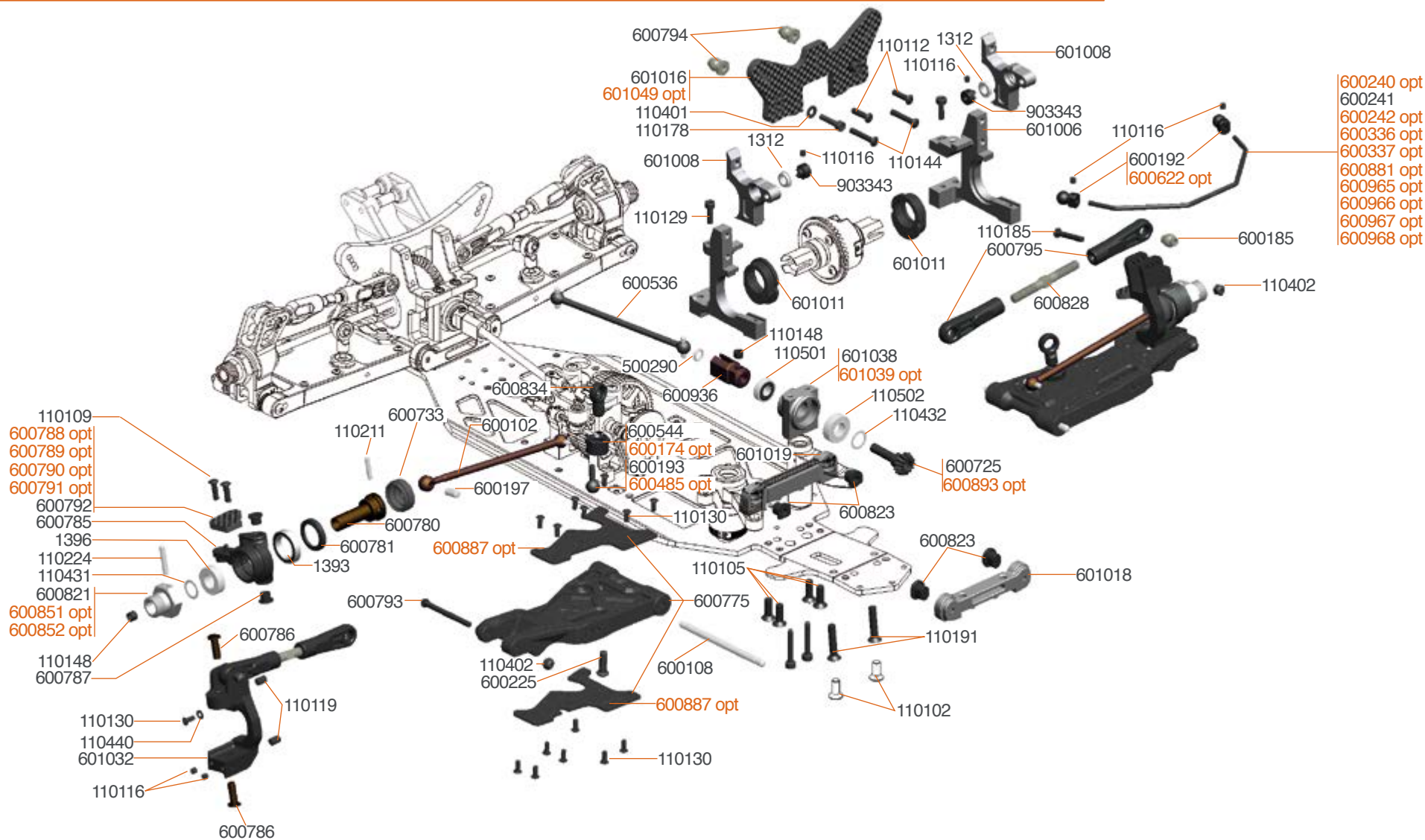

- 600174 Antirollbar nut (2)
- 600336 Antiroll bar front 1.8mm
- 600337 Antiroll bar front 2.0mm
- 600240 Antiroll bar front 2.3mm
- 600242 Antiroll bar front 2.7mm
- 600484 Antirollbar spacer 3mm alu (2)
- 600485 Pivotball threaded anti roll bar alu (2)

- 600622 Pivotball antirollbar alu (4)
- 600782 C-hub 13deg L+R alu SRX8
- 600784 C-hub 17deg L+R alu SRX8
- 600788 Steering arm 0 carbon (2) SRX8
- 600789 Steering arm 1 carbon (2) SRX8
- 600790 Steering arm 2 carbon (2) SRX8
- 600791 Steering arm 3 carbon (2) SRX8

- 600851 Wheelhexagon 0mm light (2) SRX8
- 600852 Wheelhexagon +1mm light (2) SRX8
- 600881 Antiroll bar front 3.0 mm
- 600887 Wishbone insert carbon FR Lower SRX8 (2)
- 600888 Wishbone insert carbon FR Upper SRX8

- 600891 C-hub 19deg L+R alu SRX8
- 600893 Overdrive diff pinion 13T SRX8
- 600965 Antiroll bar front 2.2 mm
- 600966 Antiroll bar front 2.4 mm
- 600967 Antiroll bar front 2.6 mm
- 600968 Antiroll bar front 2.8 mm
- 601049 Shock Tower FR Straight arm SRX8



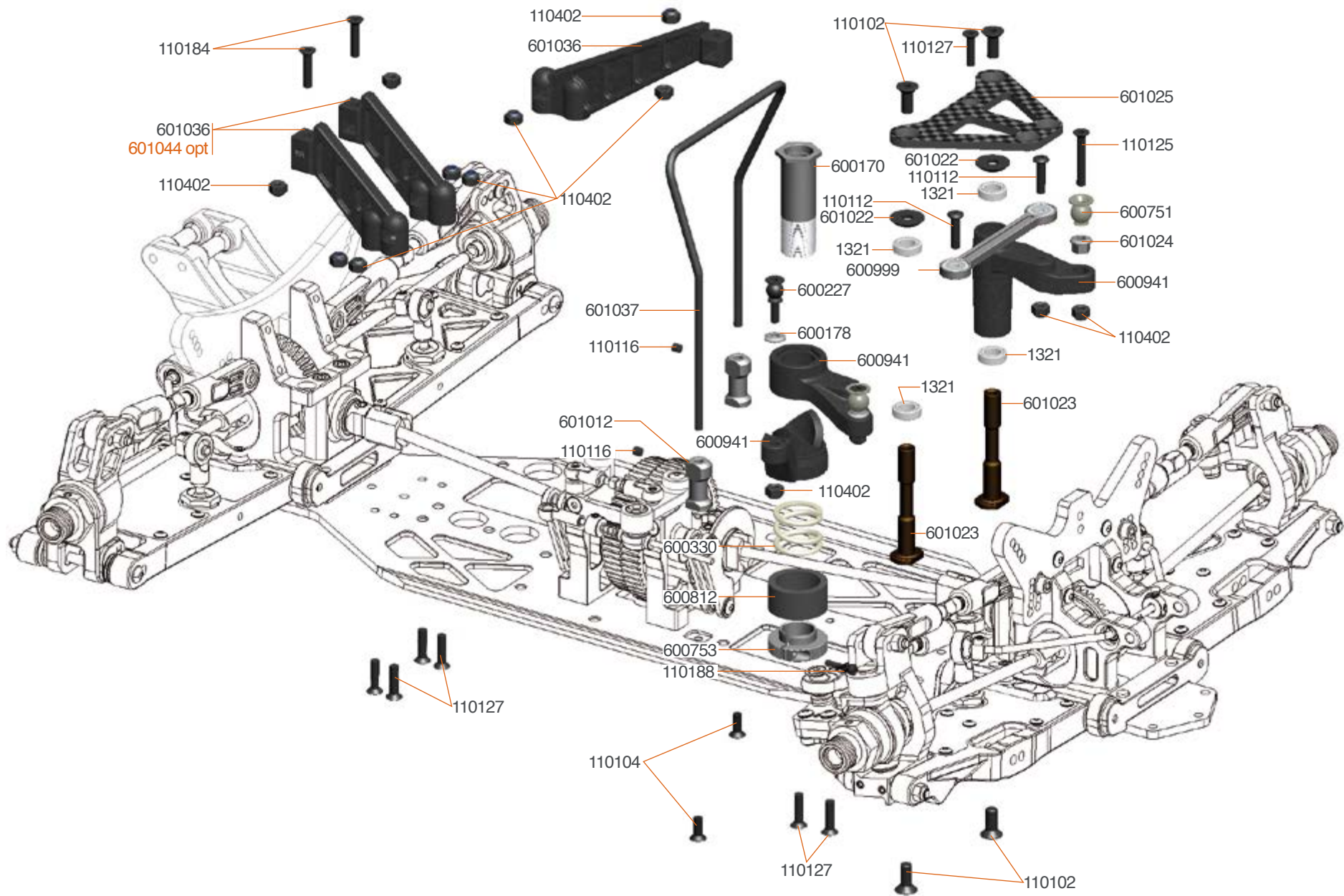

601044 Transmission brace rr alu SRX8 GT (2)





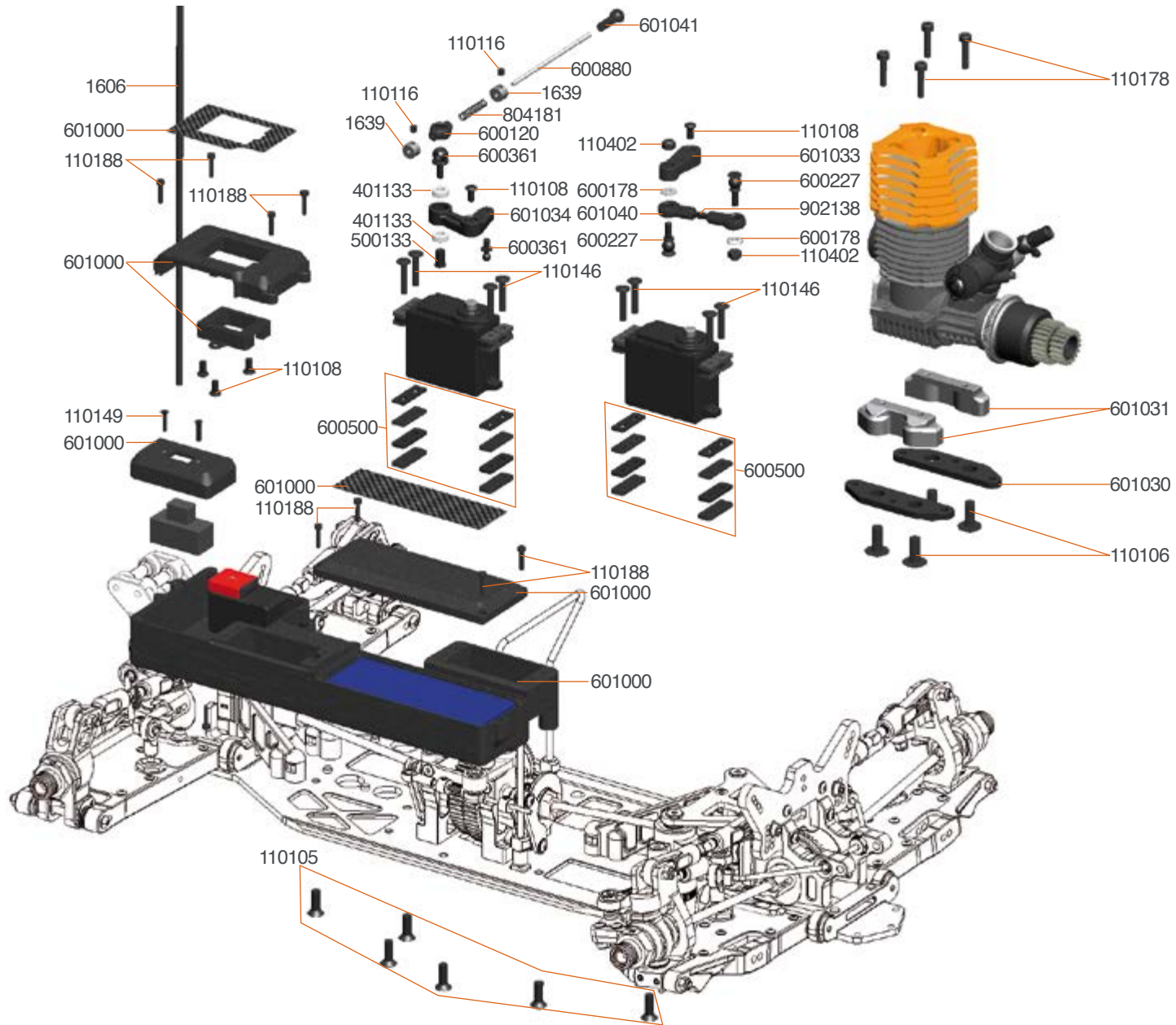

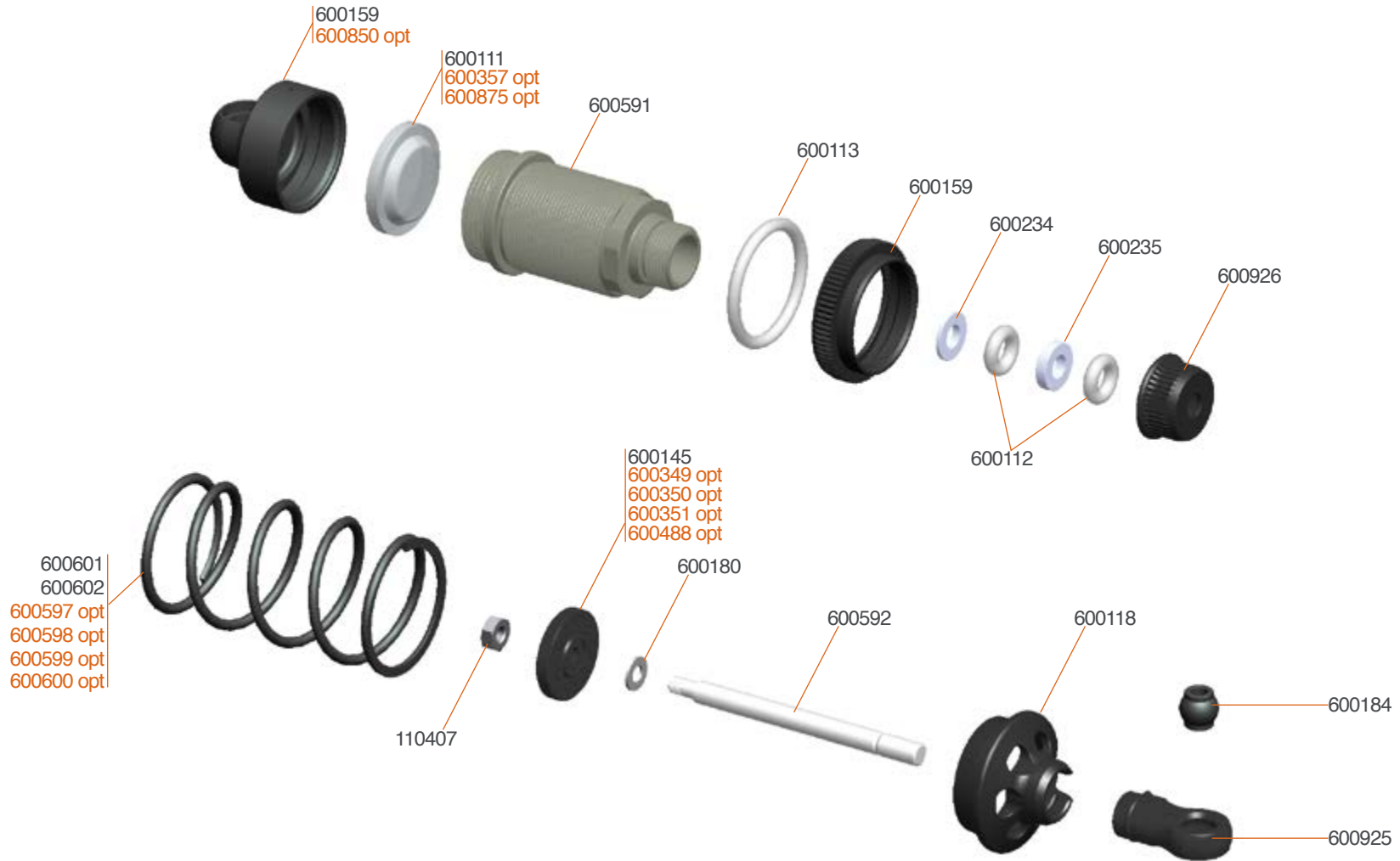

600595 Shockset fr/rr 811GT (2)



600595 Shockset fr/rr 811GT (2)  
 600597 Spring Fr/Rr Red 811GT 18lbs (2)  
 600598 Spring Fr/Rr Purple 811GT 21lbs  
 600599 Spring Fr/Rr Yellow 811GT 29lbs

600600 Spring Fr/Rr White 811GT 31.5lbs  
 600357 Membrane webbed silicone (4)  
 600875 Shock top gasket (4) SRX8  
 600349 Shock pistons conical 6 hole (4)

600350 Shock pistons conical 8 hole (4)  
 600351 Shock pistons conical 10 hole (4)  
 600488 Shock pistons square 8 hole (4)  
 600850 Shock cap pro hard coated (2) SRX8

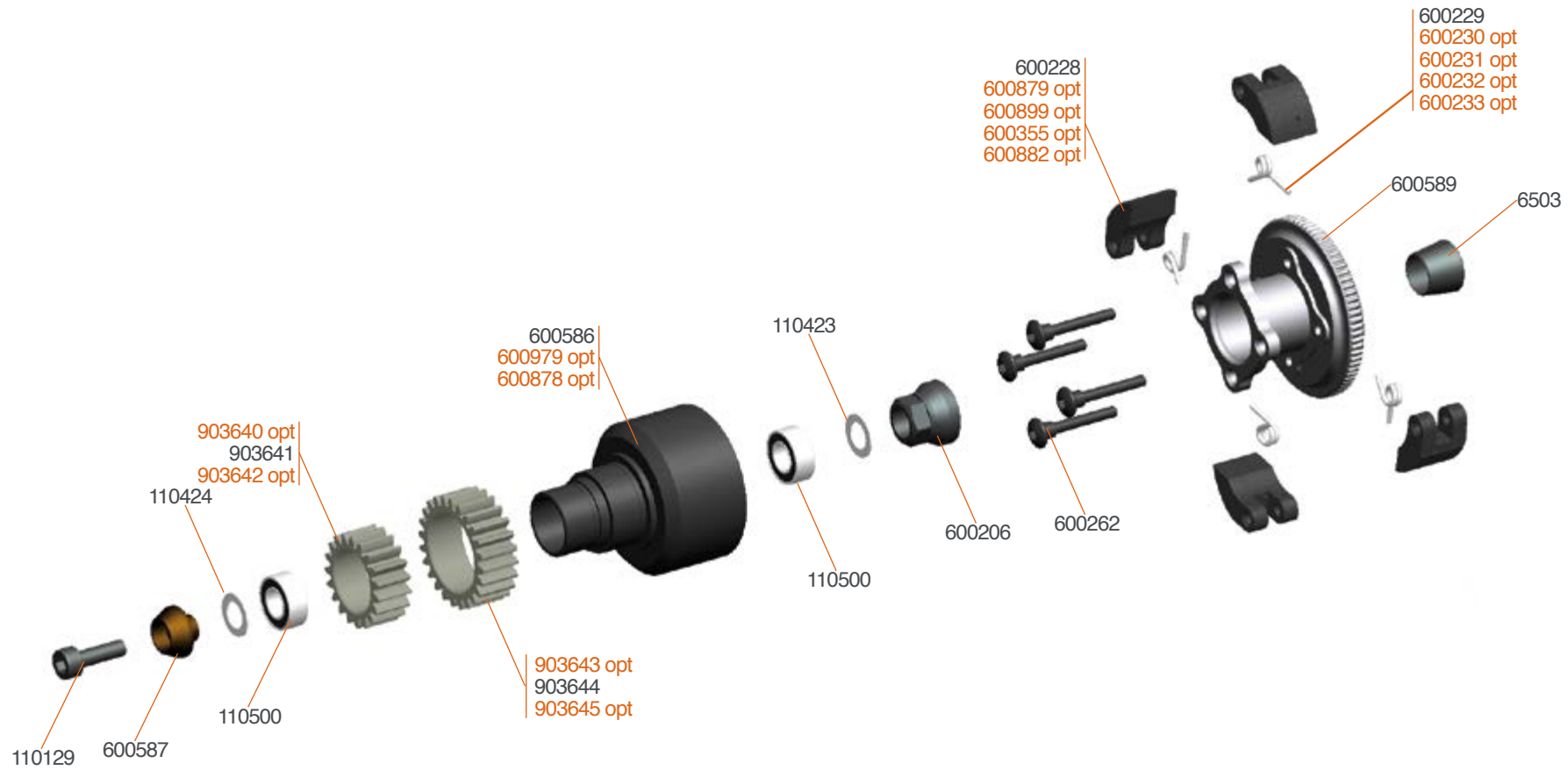

600979 Clutch-bell 2-speed vented GT  
 600878 Clutch-bell 2-speed alu nickel coated GT  
 903640 Centax gear-pinion alu 18T XLI  
 903642 Centax gear-pinion alu 20T XLI  
 903643 Centax gear-pinion alu 23T XLI

903645 Centax gear-pinion alu 25T XLI  
 600230 Clutch spring soft 0.85mm (4)  
 600231 Clutch spring hard 0.95mm(4)  
 600232 Clutch spring X hard 1mm(4)  
 600233 Clutch spring set (4x4)

600355 Clutch shoe set Alu / Carbon (2+2)  
 600879 Clutch shoe yellow (4)  
 600882 Clutch shoe 4-pin alu 6061 (4)  
 600899 Clutch shoe-springs set (2+2) 811- SRX8





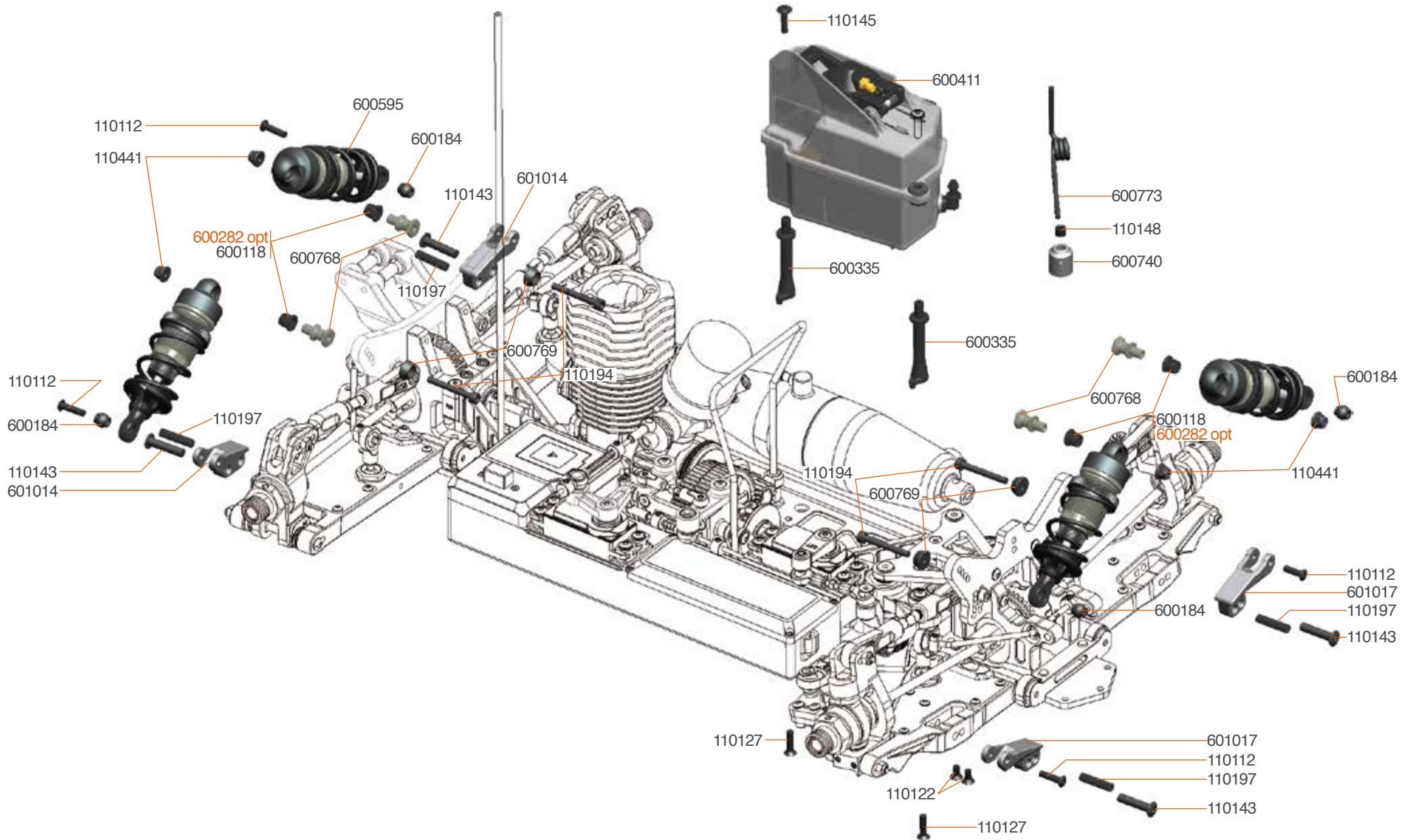

600282 Shock-pivot bushing delrin (4)

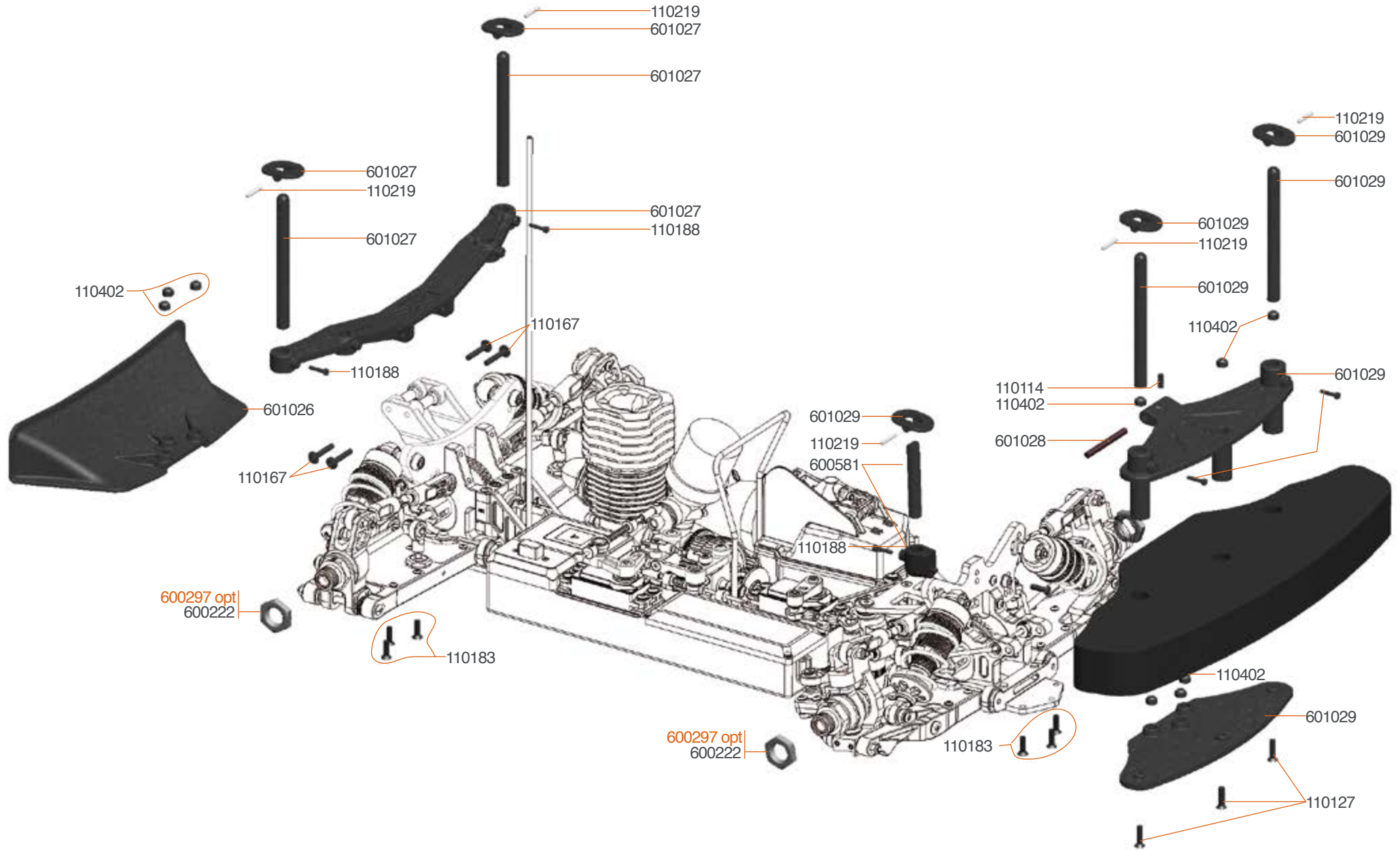

600297 Wheel-nut 17mm flanged/light (4)





# TEAM SERPENT NETWORK

**SRX8 GT SPARE PARTS** [www.serpent.com/600057/spares/](http://www.serpent.com/600057/spares/)



**SRX8 GT OPTIONALS PARTS** [www.serpent.com/600057/Optionals/](http://www.serpent.com/600057/Optionals/)



**SERPENT TOOLS** [www.serpent.com/product/Tools/](http://www.serpent.com/product/Tools/)

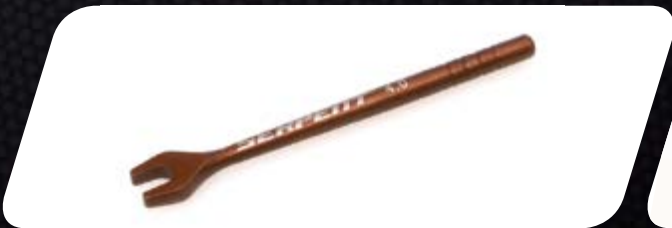

**SERPENT MERCHANDISING** [www.serpent.com/product/Merchandising/](http://www.serpent.com/product/Merchandising/)







## SERPENT WEBSITE AND BLOG

[www.serpent.com](http://www.serpent.com)  
[www.teamserpent.com](http://www.teamserpent.com)  
[www.dragon-rc.com](http://www.dragon-rc.com)

**SERPENT PROMO PAGES** <http://promo.serpent.com>

**SERPENT FACEBOOK GROUPS** <http://promo.serpent.com/indexfb.htm>

**SERPENT ADVANCED MANUALS** <http://promo.serpent.com/sam/>

## SERPENT SOCIAL MEDIA



[www.facebook.com/SerpentMRC](http://www.facebook.com/SerpentMRC)



[www.youtube.com/user/SerpentMRC](http://www.youtube.com/user/SerpentMRC)



[www.twitter.com/SerpentMRC](http://www.twitter.com/SerpentMRC)



[www.plus.google.com/+SerpentModelcars/posts](http://www.plus.google.com/+SerpentModelcars/posts)



[www.weibo.com/teamserpent](http://www.weibo.com/teamserpent)



**SERPENT**





# SRX8 GT

1/8 SCALE

WORLD  
CHAMPIONS  
10X

SERPENT



SRX8 GT Manual #83144