

Project FX EVO

1/10 scale electric touring car

Instruction Manual

SPT
SERPENT

INTRODUCTION

Thank you very much for selecting this Serpent rc car and thus become a member of the ever growing worldwide Serpent racing family. Serpent started in 1980 and has been growing its product-line and fan-base ever since.

The Serpent Project 4X EVO is a state of the art 1/10 scale 4wd touringcar which will give you the true Serpent racing experience. The assembly manual will guide you through all the steps to complete the car, so you can hit the track with a good base-set-up soonest. The Serpent design department succeeded to create a superbly performing car combined with eas of assembly and maintenance. The high quality standards of all parts and hardware will make racing your Serpent car a very rewarding activity!

Through our team, website and social media we will keep you up-to-date on all developments of the Serpent cars. We hope to meet you on the track and through our various media! Enjoy the drive!

Team Serpent
Multiple World Champions

INSTRUCTIONS

Serpent's long tradition of excellence extends to the instruction manuals, and this instruction manual is no exception. The easy-to-follow layout is richly illustrated with 3D-rendered full-color images to make your building experience quick and easy. Following the instructions will result in a well-built, high-performance race-car that will soon be able to unleash its full potential at the racetrack. The kit includes bags, with bagnumbers, which refer to the same step in the manual. Open only the indicated bag(s) per step and finish that part of the assembly. Remaining parts will be needed lateron in the assembly process.

PLASTIC PARTS

The Serpent moulded parts are very durable and hard. When assembling longer screws in new composite parts, make sure to use new hex bits in your (power) tools. Pre-threading also helps to avoid screw damage.

SETUP

In certain assembly steps you need to make basic adjustments, which will give you a good initial setup for your Serpent Project 4X EVO. Fine-tuning the initial setup is an essential part of building a high-performance racecar like your Serpent Project 4X EVO.

EXPLODED VIEWS AND PARTS LIST

The exploded views and parts lists for the Serpent Project 4X EVO are presented in the Reference Guide section in the back of this manual. The exploded views show all the parts of a particular assembly step along with the Serpent part number and hotlink to the Serpent website. Partnumbers in orange indicates that this part is an optional. Optionals part names and numbers are showed below.

CUSTOMER SERVICE

Serpent has made a strong effort to make this manual as complete and clear as possible. Additional info may be published in our website: www.serpent.com or you may ask your dealer or the Serpent distributor for advice, or email Serpent direct: info@serpent.com. The Serpent Facebook, Twitter and Youtube pages give additional means of support and communications.

SAFETY

Read and take note of the 'Read this First section' before proceeding to assemble the car-kit. This car-kit is intended for persons aged 16 or older.

READ THIS FIRST!

- This is a highly technical hobby product, intended to be used in a safe racing environment. This car is capable of speeds in excess of 80 km/h or 50mph. Please follow these guidelines when building and operating this model.
- Parental guidance is required when the builder/user of this car is under 16.
- Follow the building instructions. If in doubt, contact your dealer or importer.
- Be sure to use the proper tools when assembling the car. Always exercise caution when using electric tools, knives and other sharp objects.
- Be careful when using liquids like lubrication oil, fuel or glue. Do not swallow.
- Follow the manufacturer's instruction in case you experience irritation after using the product.
- Be careful when operating the car. Stay away from any rotating parts such as wheels, gears and transmission. Stay away from motor, engine and exhaust pipe system or speedo during and immediately after use, as these parts may be very hot. We advise to use protective hand cloves.
- Only operate this car in a safe environment, like a special racing track or a closed parking lot. Avoid using this car on public roads, crowded places or near infants.
- Before operating this car, always check the mechanical status of the car. Also check that the transmitter and receiver frequencies correspond and are not used by any other racer at the same time. Check that the batteries of the transmitter and receiver- are fully charged.
- After use, always check all the mechanics of the car. We advise to clean the car immediately after use, and inspect the parts for wear or fractures. Replace when necessary. Do not use water, methanol, thinner or other solvents to clean the car.
- Empty the fuel tank (depending on model) if needed and disconnect the receiver battery.
- Store the car in a dry and heated place to avoid corrosion of metal parts.
- Avoid using this car in wet conditions as the water will cause corrosion on the metal parts and bearings and these parts will cease to function properly. If driven in the wet, ensure that all the electric equipment is waterproofed and after use, that all moving parts are dried immediately.

CONTENTS

• DIFF ASSEMBLY	4
• SHOCKS ASSEMBLY	6
• ROLL DAMPER ASSEMBLY	8
• CENTRAL AND REAR I ASSEMBLY	10
• FRONT I ASSEMBLY	15
• TRANSMISSION ASSEMBLY	20
• FRONT II ASSEMBLY	23
• REAR II ASSEMBLY	29
• FINAL ASSEMBLY	32
• EXPLODED VIEWS	41
• TEAM SERPENT NETWORK	50

LINES DESCRIPTION

Each step contains a variety of numbers, lines, and symbols. The numbers represent the order in which the parts should be assembled. The lines are described below.



Step number; the order in which you should assemble the indicated parts



Length after assembly



Assembly path of one item into another



Group of items (within lines) should be assembled first



Direction the item should be moved



Glue one item to another



Press/Insert one item into another



Connect one item to another



Gap between two items

ICONS DESCRIPTION

Each step contains a variety of symbols described below.



Carefull, read and check very well.



Apply a small amount of cyano glue. Use wear protection for eyes and hands.



Detail view to explain assembly or order of parts better.



Default set-up: This symbol indicates the default setup.



Grease: apply a small amount of grease to the parts shown.



Silicone grease: apply a small amount of grease to the parts shown.



Left and right parts should be assembled in the same way.



Thread lock: apply a small amount on the parts shown. Before to apply the threadlock, make sure to degrease the parts very well, as otherwise the threadlock will not work.



Silicone oil: use the indicated silicone oil for the shocks and differentials.



Parts or items not included in the kit.



Optional part, not standard in the kit.

STEP 1 DIFF BAG

1.1

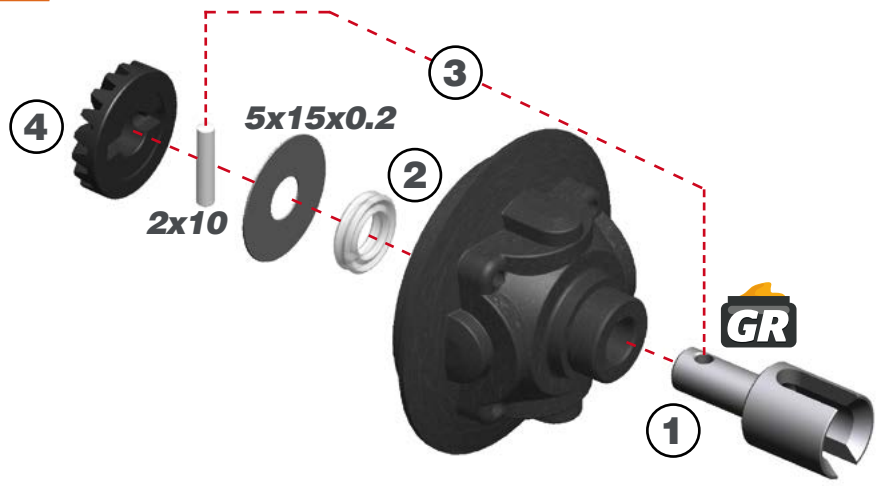

1.2

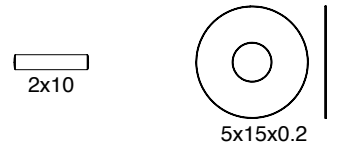
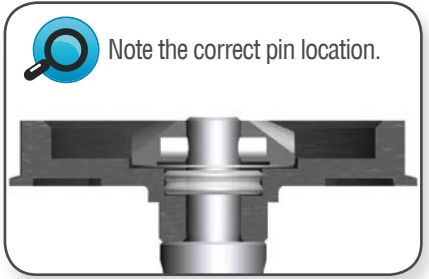
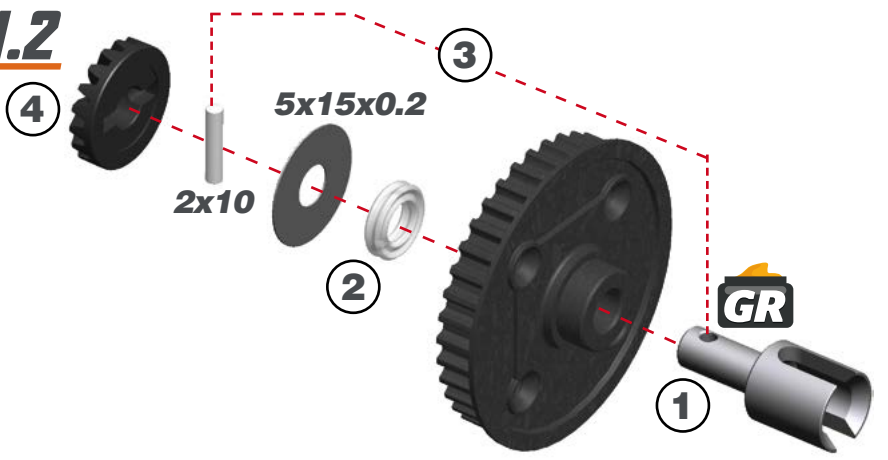

STEP 2

- 1- Fit the o ring before filling the diff with silicone oil.
- 2- Add just enough oil to cover the large gear before assembling the small satellite gears and cross pins. Use the silicone oil supplied in the kit. For the correct cst value please check the default setupsheet.

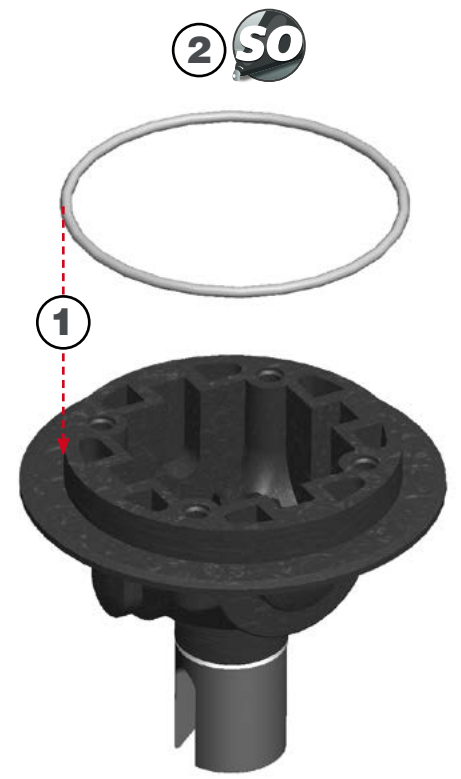

STEP 3

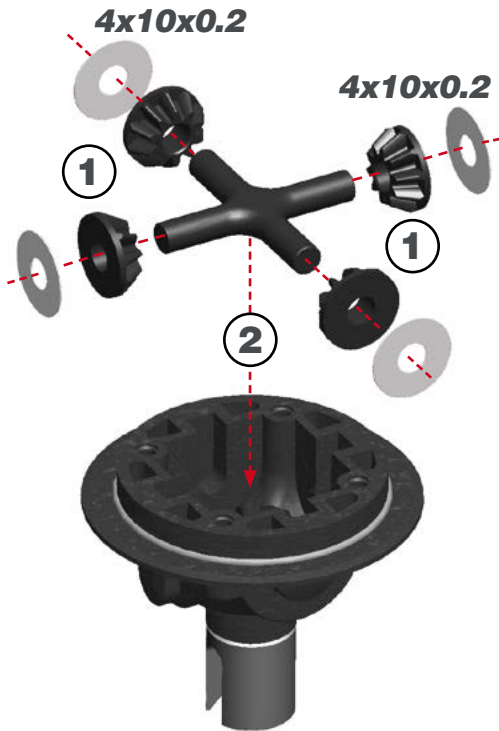

STEP 4



Fill the differential with silicone oil 1 mm above the crosspin, do not overfill. Use the silicone oil supplied in the kit. For the correct cst value please check the default setupsheet.

50



AMOUNT OF OIL IN THE DIFFS

Use a digital scale to measure the exact amount of oil in the diff.

Differential weight = 11.4 grams



STEP 5

M2.5x12



Do not overtighten the screws. There is always a gap between both sides of the diff housing.

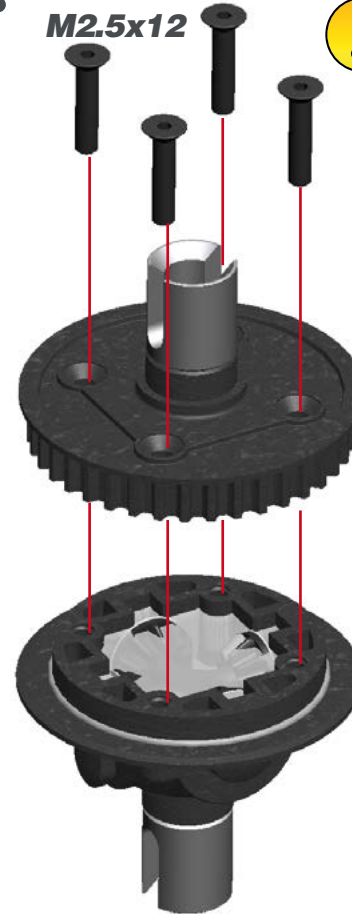

COMPLETE DIFF ASSEMBLY



STEP 6

BAG 1

STEP 7

STEP 8



Follow step 6 to 11 twice to assemble 2 shocks, 1 for the front and 1 for the rear.

Check the default set-up sheet to find the right values for piston, spring and silicone oil. Be aware that front and rear shock-settings may differ.

6.1

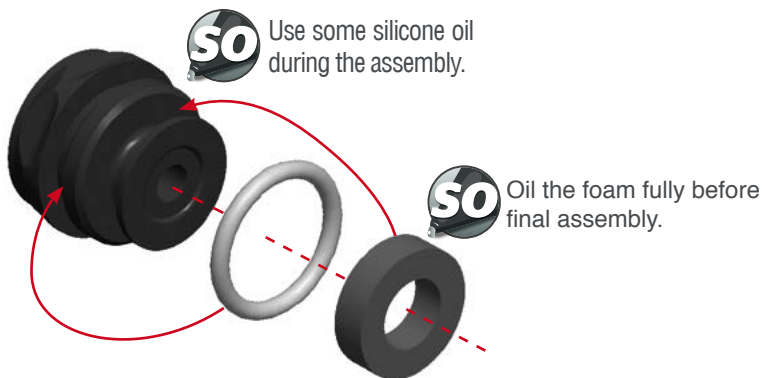

6.2

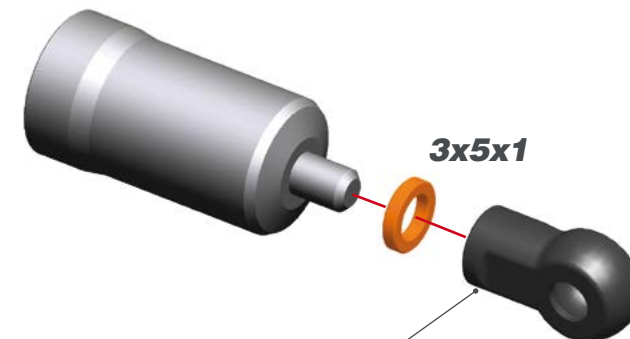
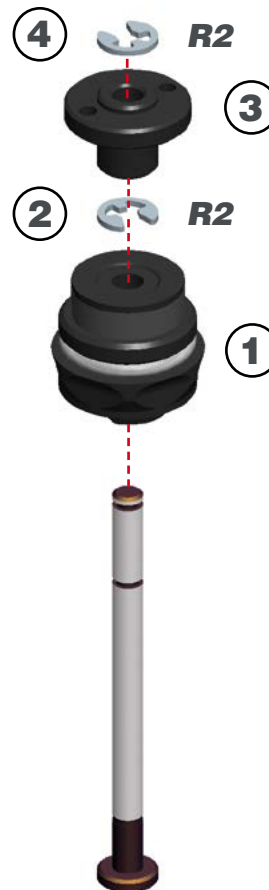
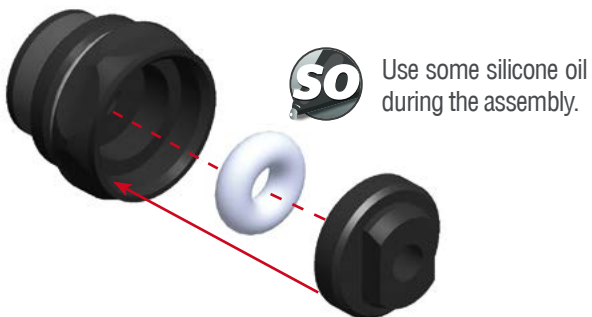

Mount the shim and balljoint, then tighten. This way the small bleeder hole in the threaded shaft is closed.

R2

3x5x1

STEP 9

1- Fill up with silicone oil fully using the silicone oil supplied in the kit. For the correct cst value please check the default setupsheet.

2- Wait untill all air bubbles have escaped.



STEP 10

1-Loosen the balljoint anti clockwise, in order to open the small bleeder hole in the threaded shaft and push the piston into the housing and screw the cap assembly gently onto the shock housing clockwise, do NOT overtighten.

2-Bleeding: Turn the shock upside down and push the shockrod slowly fully inside, so the excess oil can escape through the small bleeder hole in the threaded shaft. Wipe away the excess oil. Keep opened yhe balljoint to let excessive oil come out

3-With shockrod fully in, close the shock and balljoint fully.

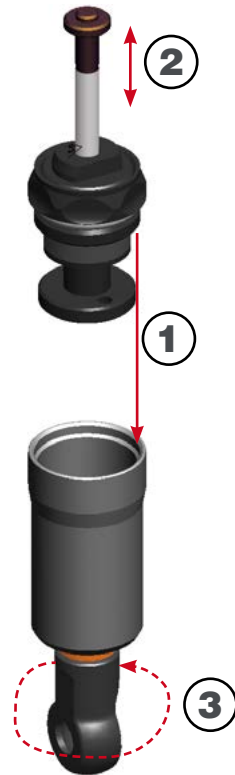

STEP 11

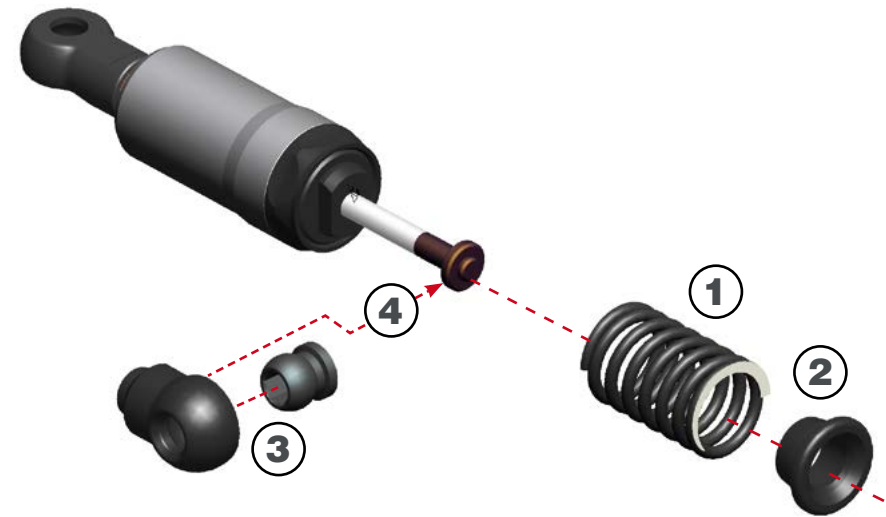

Note the correct position of the shock spring support and ball joint.

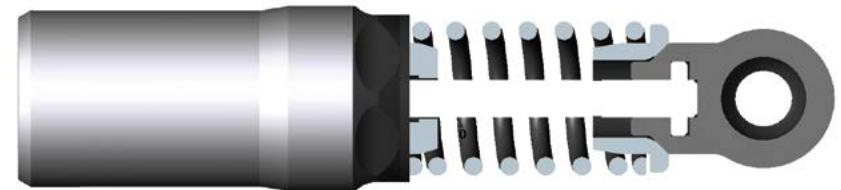

STEP 12 BAG 2

! Follow step 12 to 16 twice to assemble 2 roll dampers, 1 for the front and 1 for the rear.
 Check the default set-up sheet to find the right values for piston, spring and silicone oil. Be aware that front and rear roll damper-settings may differ.

12.1 **!** Do not overtighten the M2x6 screw.

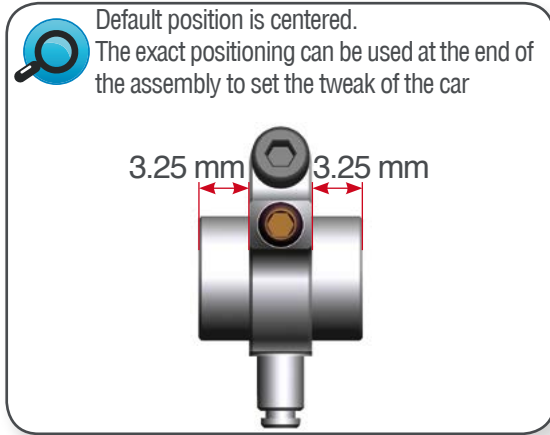
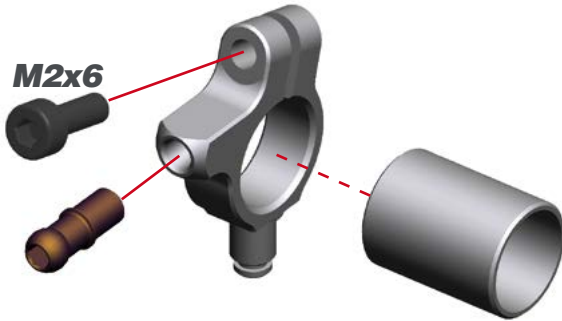

12.2 **SO** Use some silicone oil during the assembly.

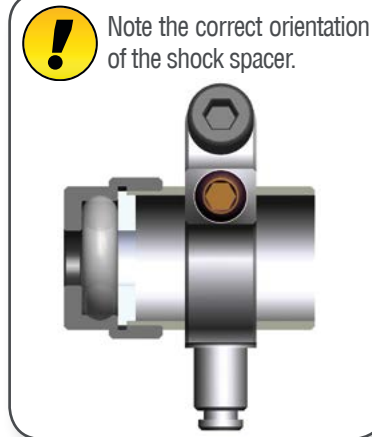
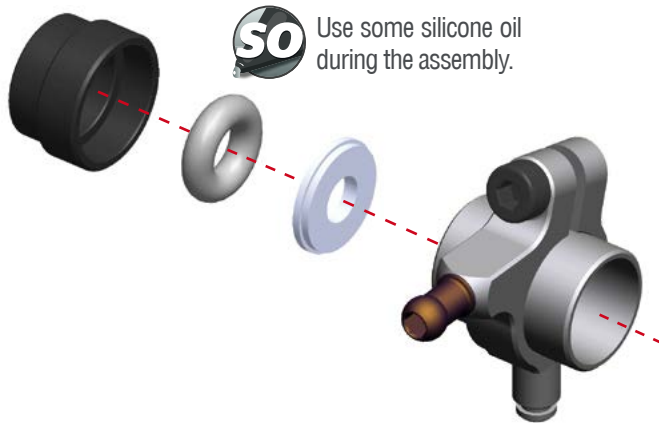

STEP 13

13.1 **!** Notice that the piston is not symmetrical. The side with the chamfer should be assembled oriented to the shock shaft.



13.2 **SO** Use some silicone oil during the assembly.

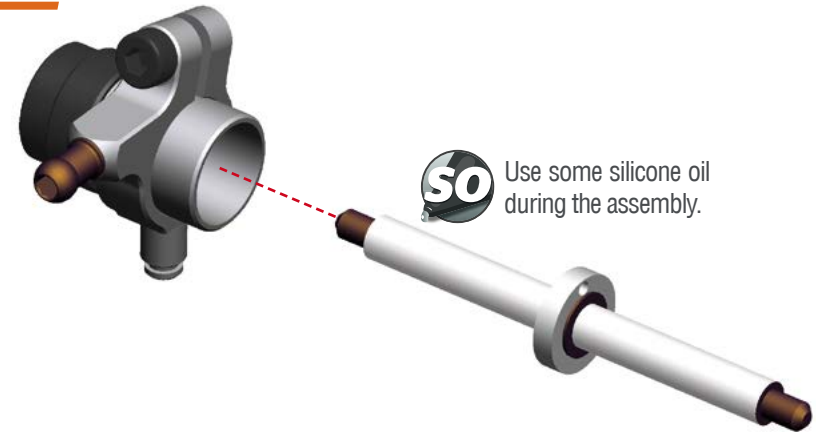

STEP 14

1- Fill up with silicone oil fully using the silicone oil supplied in the kit. For the correct cst value please check the default setupsheet.

2- Extend the shockrod fully.

3- Move the shockrod slowly up and down to let all air bubbles escape.



STEP 15



SO Use some silicone oil during the assembly.

! Note the correct orientation of the shock spacers.



STEP 16

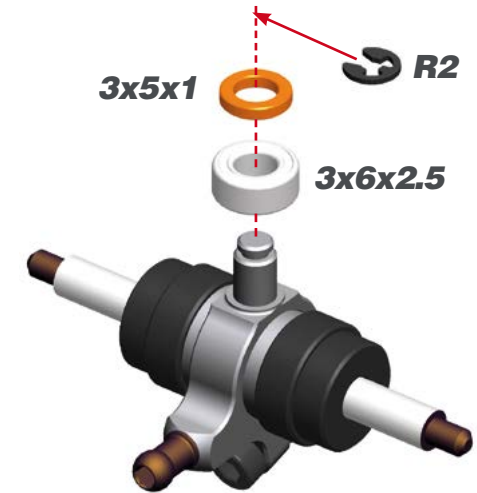

COMPLETE ROLL DAMPER ASSEMBLY



STEP 17 BAG 3

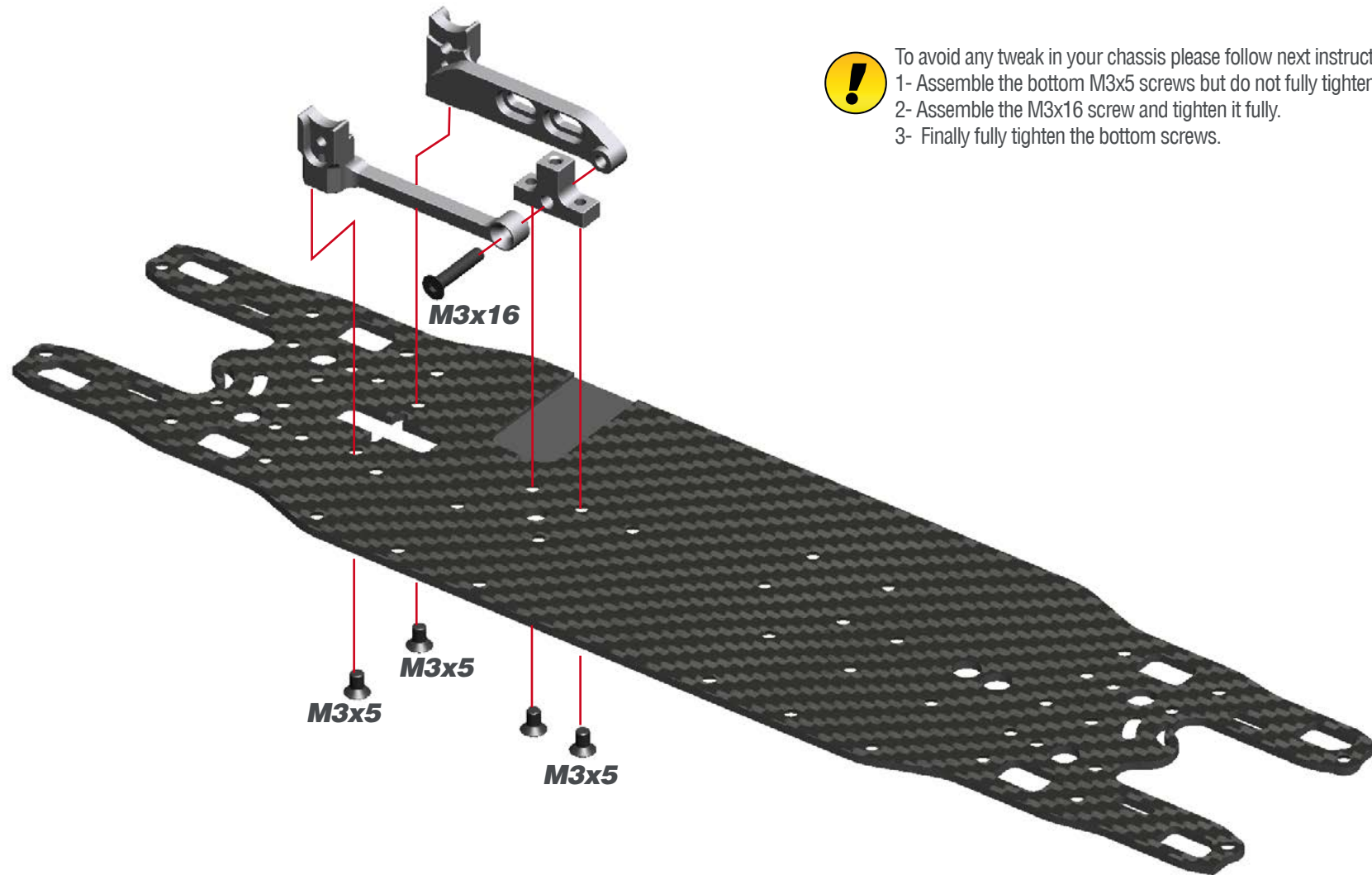

To avoid any tweak in your chassis please follow next instructions:

- 1- Assemble the bottom M3x5 screws but do not fully tighten.
- 2- Assemble the M3x16 screw and tighten it fully.
- 3- Finally fully tighten the bottom screws.



M3x5

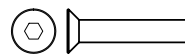

M3x16

STEP 18

STEP 19

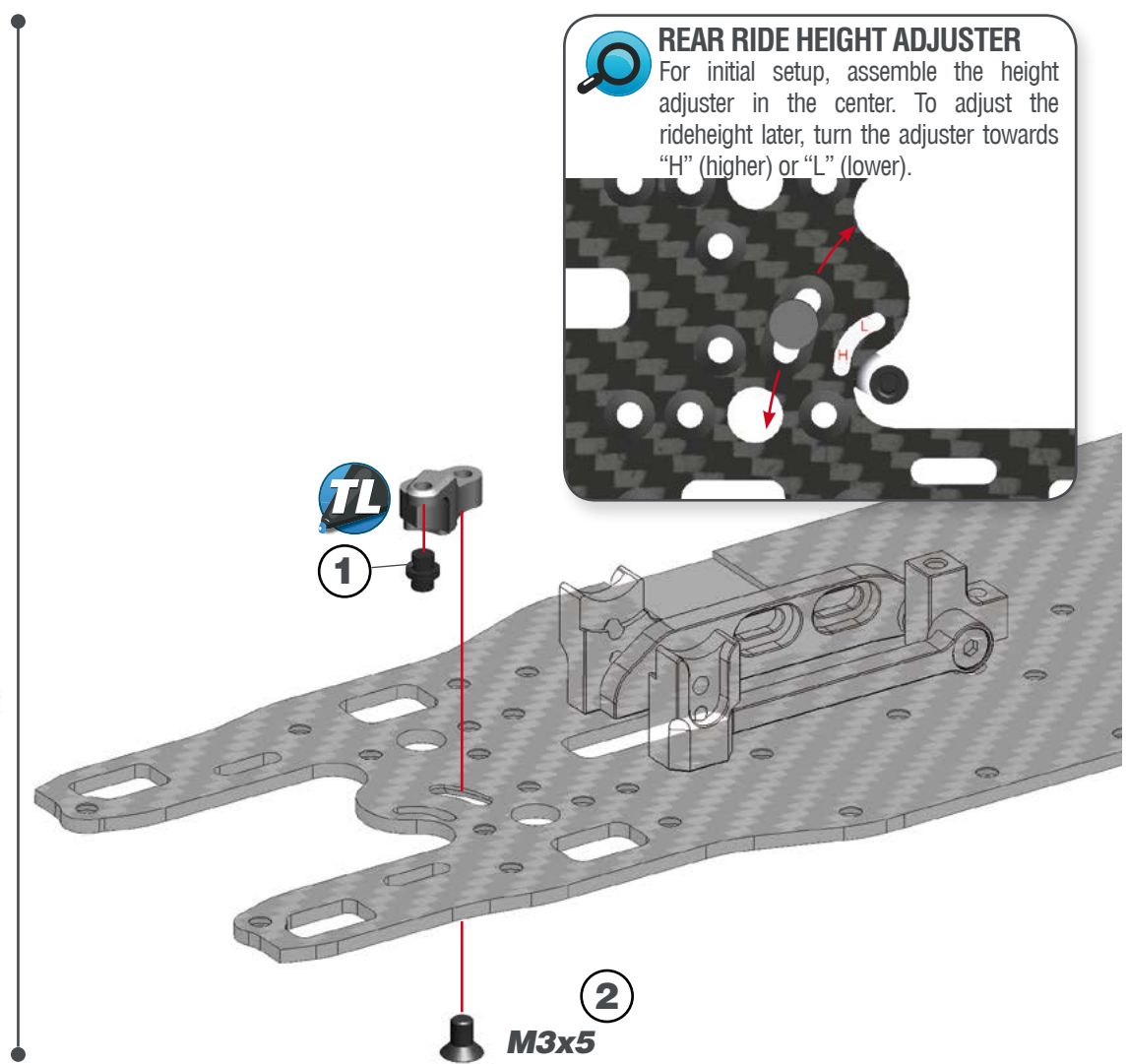
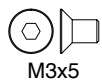
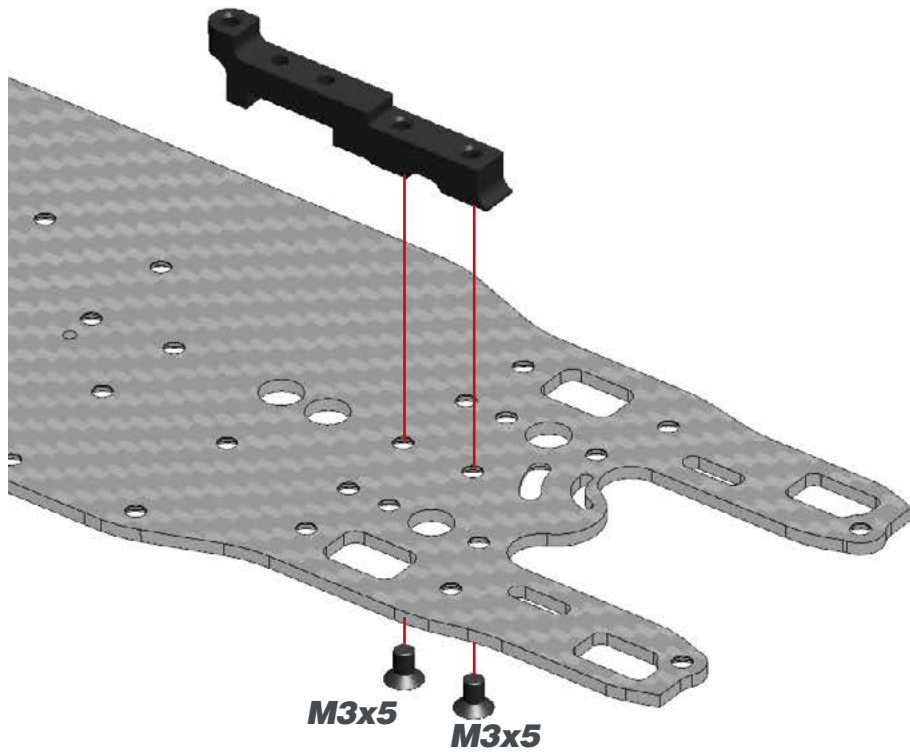

REAR RIDE HEIGHT ADJUSTER
For initial setup, assemble the height adjuster in the center. To adjust the rideheight later, turn the adjuster towards "H" (higher) or "L" (lower).



STEP 20 **BAG 4**

20.1

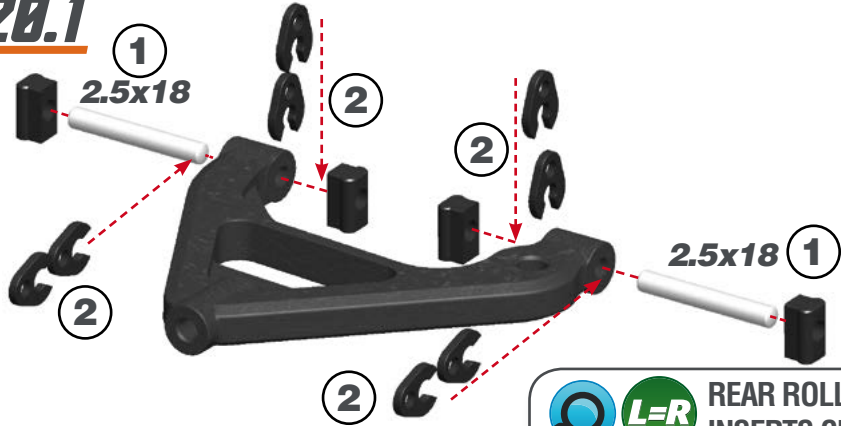

L=R REAR ROLL CENTER INSERTS CHART

MID LOW	MID HIGH	HIGH
DEF. SETUP		

20.2

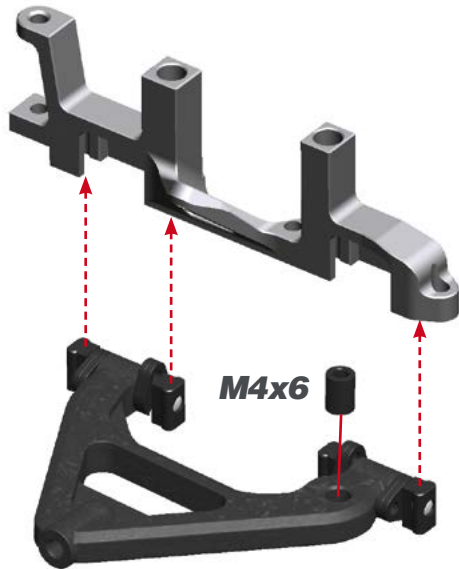

DEF. SETUP REAR DEFAULT WHEELBASE SHIMS

20.3

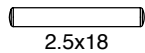
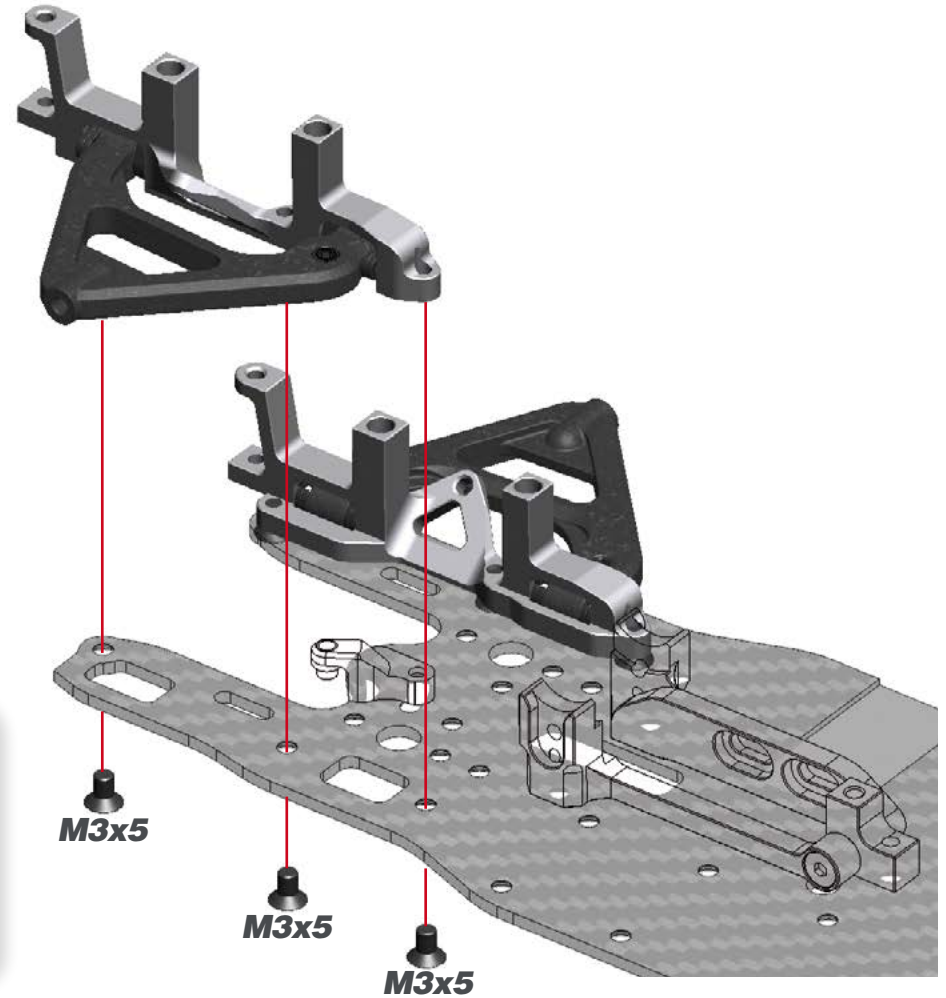

STEP 21

BAG 5

21.1



! Note the right orientation of the rocker-legs.

21.2

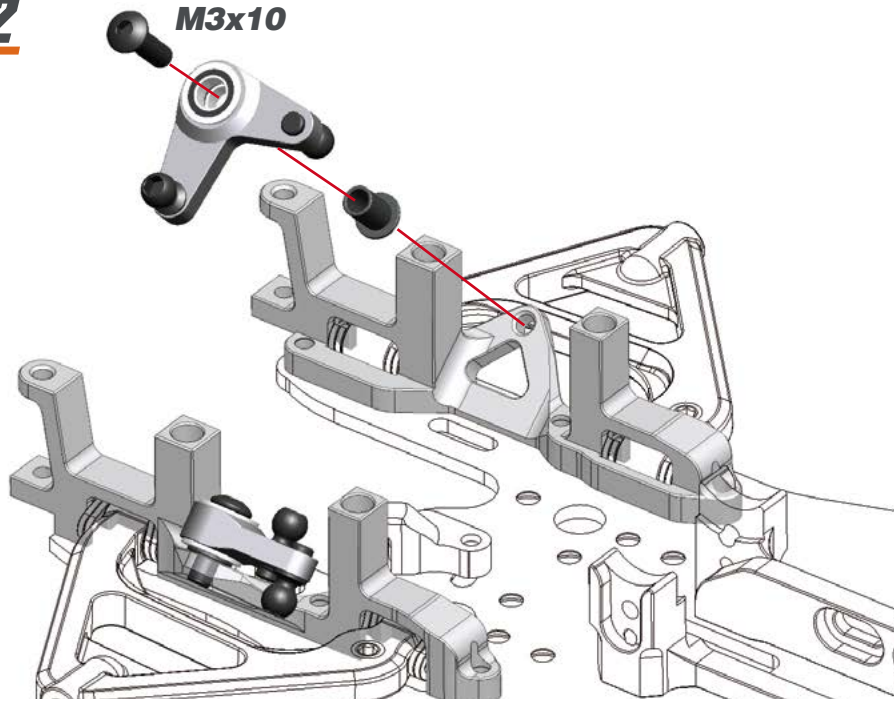

M3x10

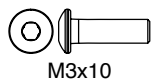

STEP 22

22.1

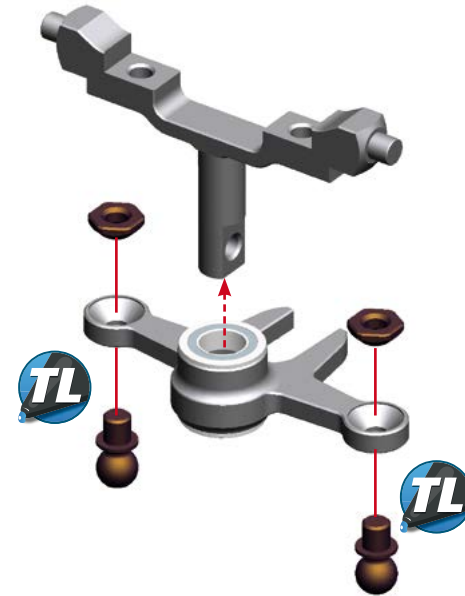

TL

TL

22.2

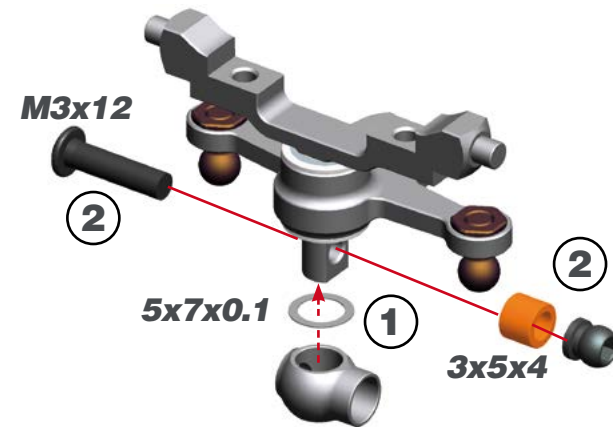

M3x12

2

5x7x0.1

1

3x5x4

2

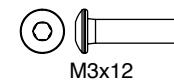

STEP 23

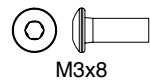
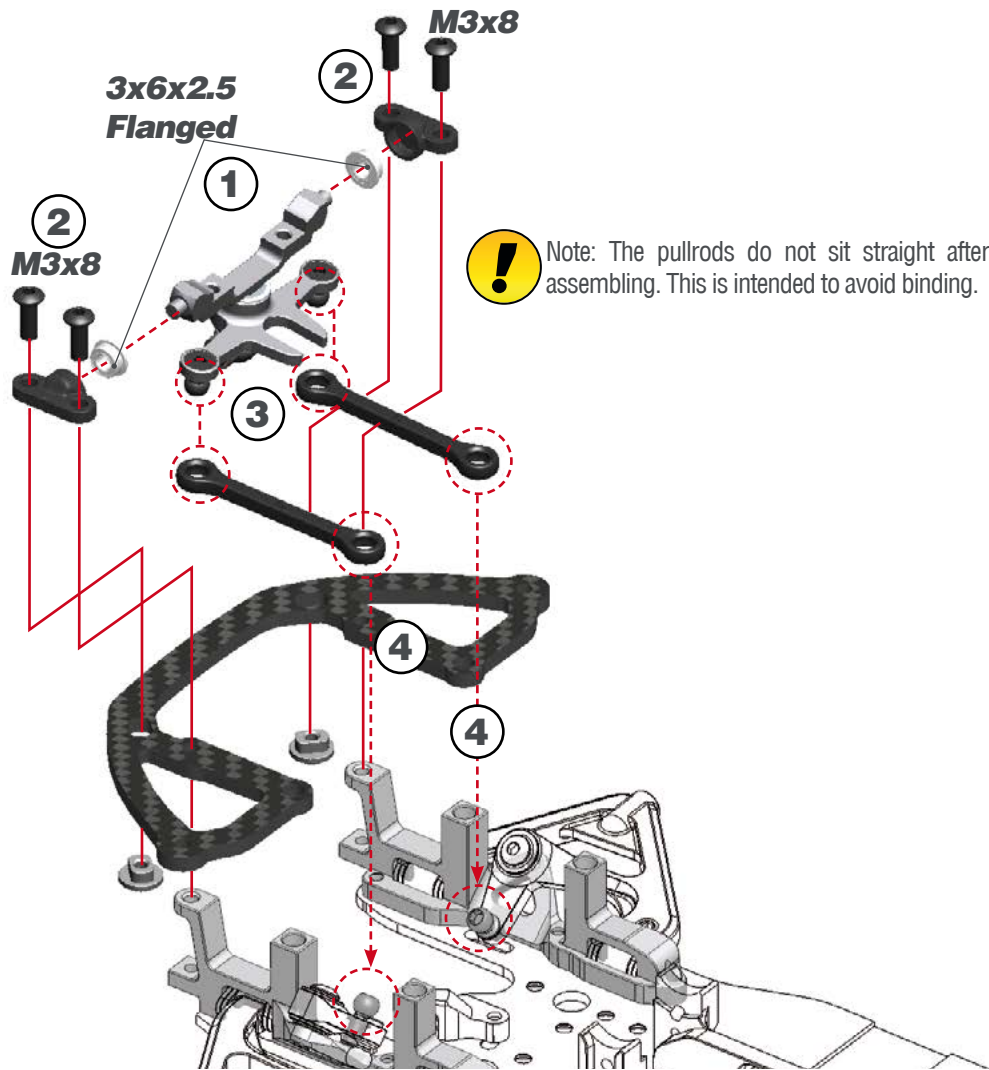

STEP 24

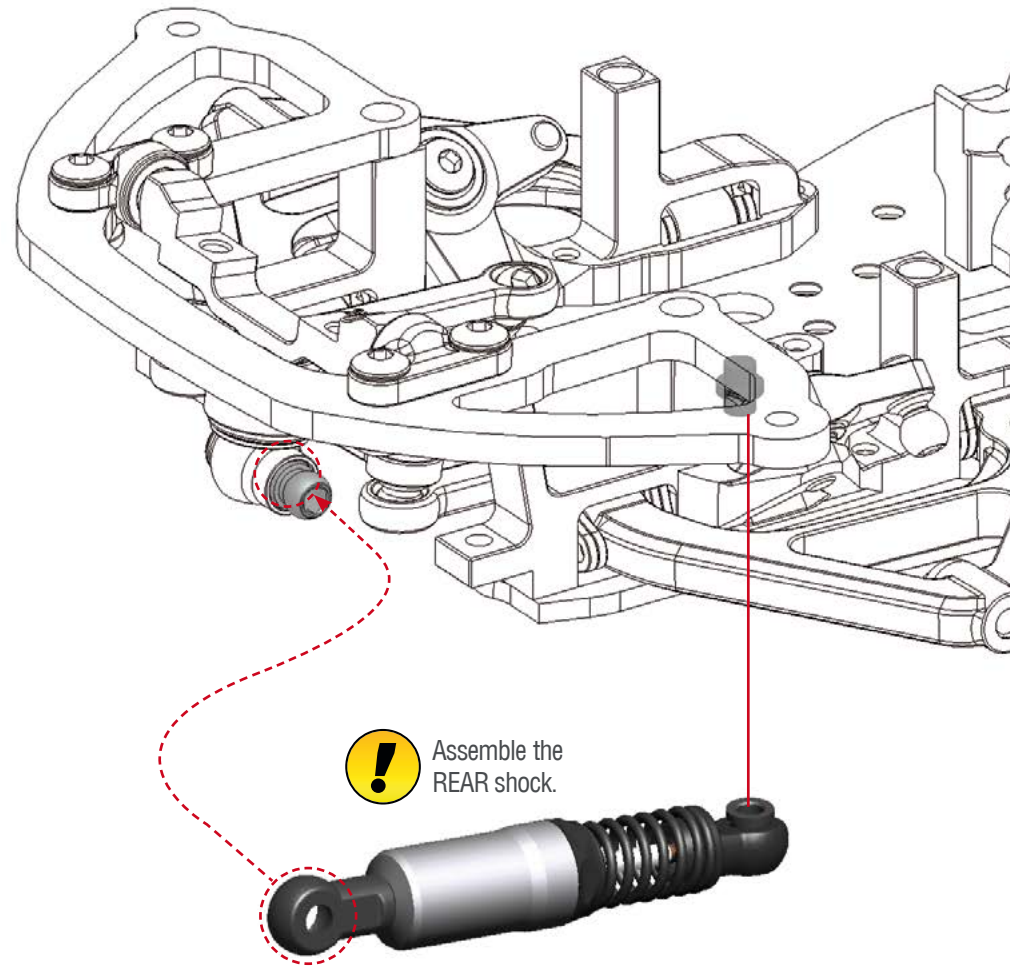

STEP 25

25.1

! Assemble the REAR rolldamper.

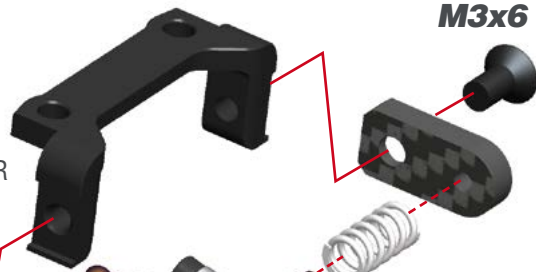

M3x6

! For the correct spring colour please check the default setupsheet.

25.2

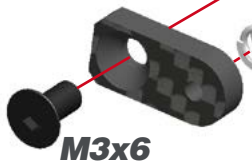

M3x6

L=R ROLL DAMPER HOLDERS LENGTH
Use the long holder (8mm)

LONG

SHORT

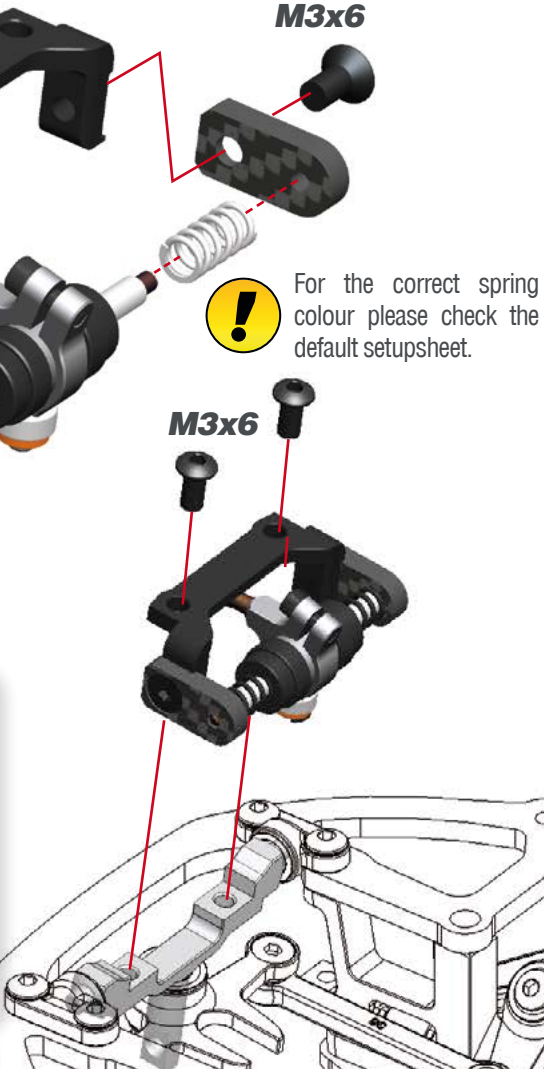

STEP 26 BAG 6

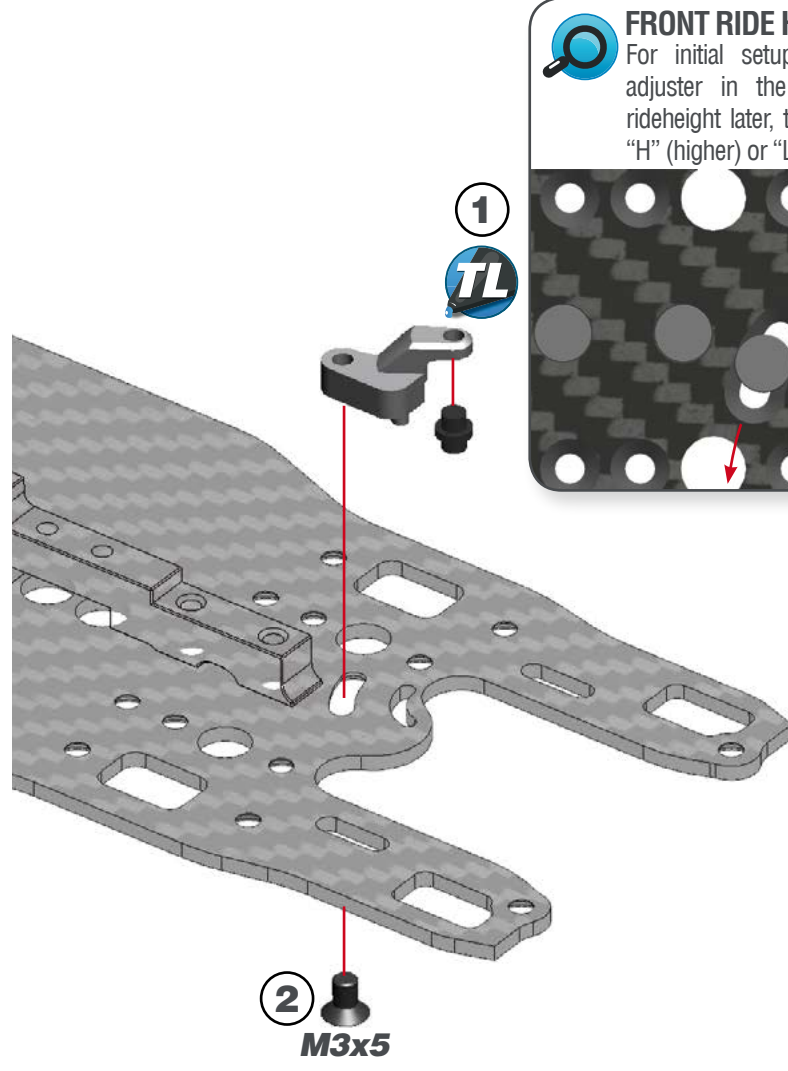

FRONT RIDE HEIGHT ADJUSTER
For initial setup, assemble the height adjuster in the center. To adjust the rideheight later, turn the adjuster towards "H" (higher) or "L" (lower).

2
M3x5

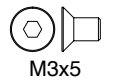
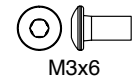
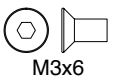

STEP 27

STEP 28

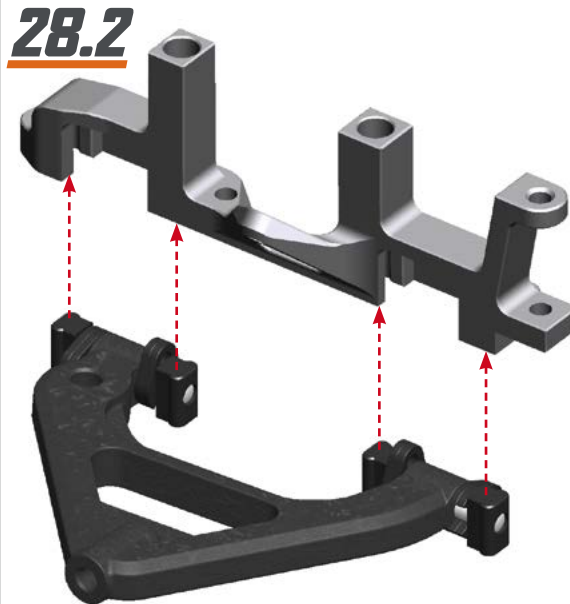
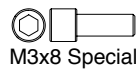
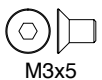
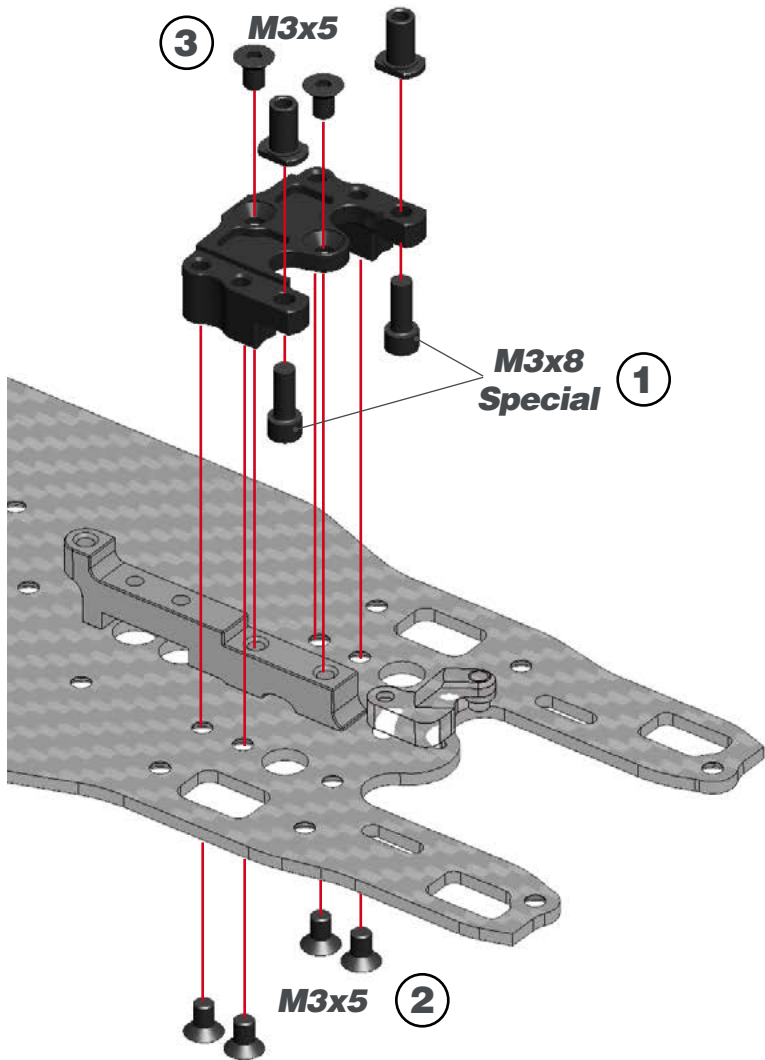

FRONT ROLL CENTER INSERTS

L-R

MID LOW	MID HIGH	HIGH
DEF. SETUP		

FRONT DEFAULT WHEELBASE SHIMS

DEF. SETUP

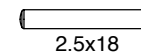

STEP 29

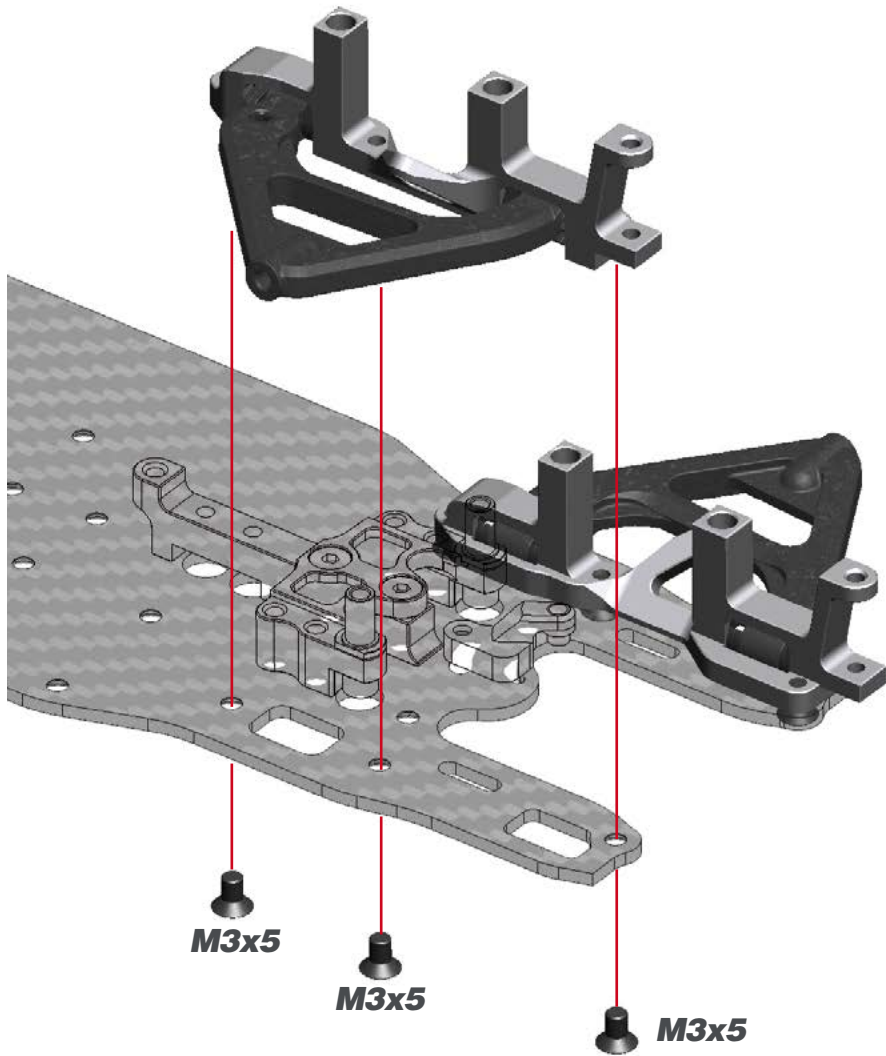

M3x5

STEP 30 **BAG 7**

30.1



Note the right orientation of the rocker-legs.

30.2

M3x10

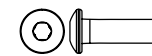
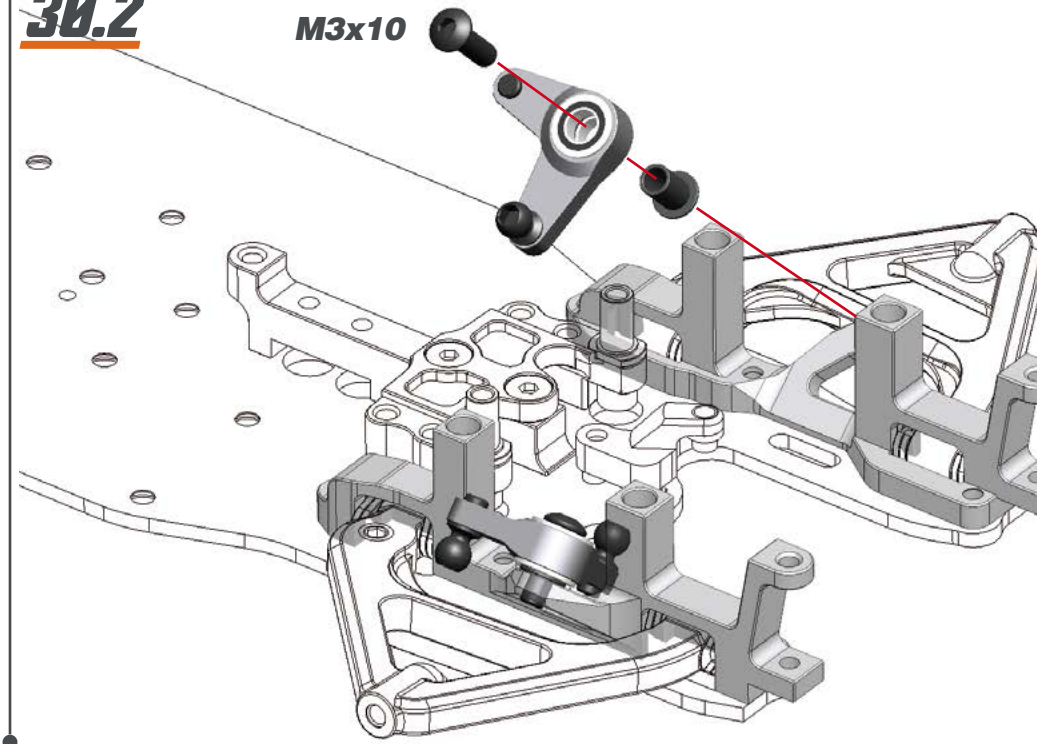

M3x10

STEP 31

31.1

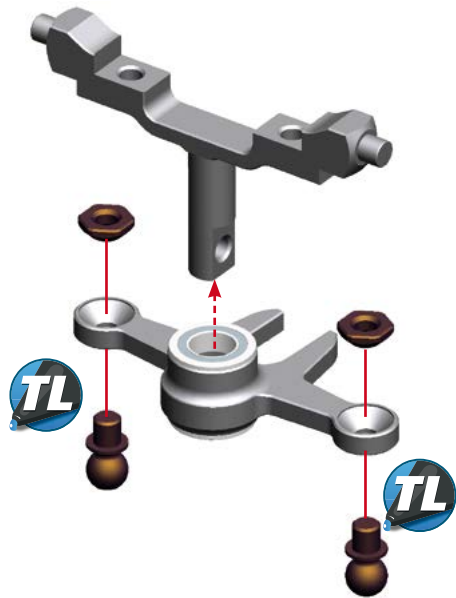

31.2

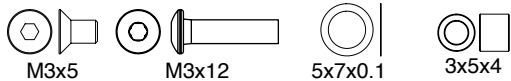
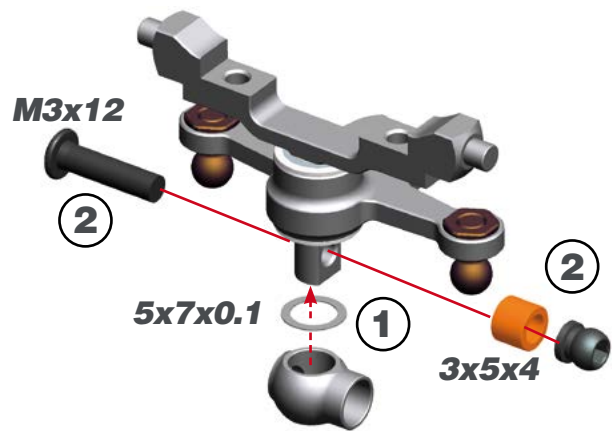

STEP 32



Note: The pullrods do not sit straight after assembling. This is intended to avoid binding.

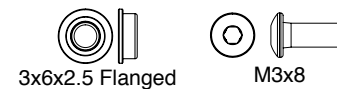
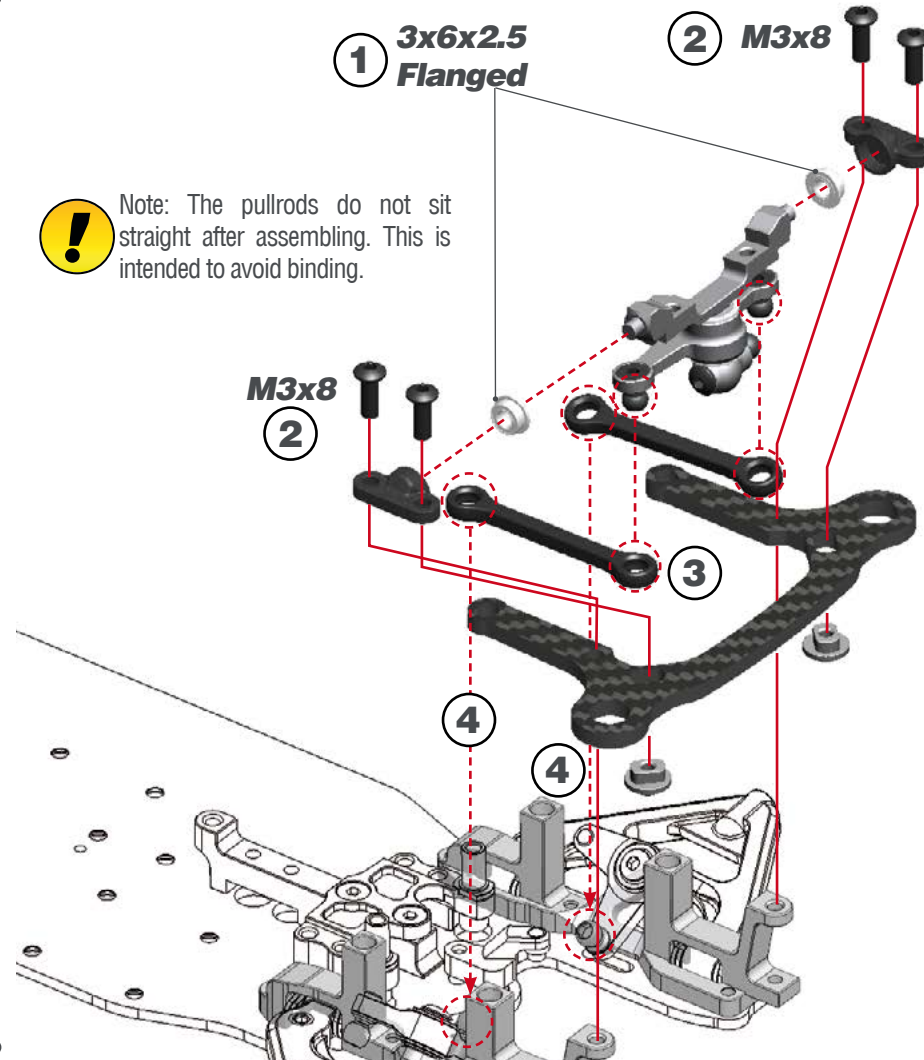

STEP 33

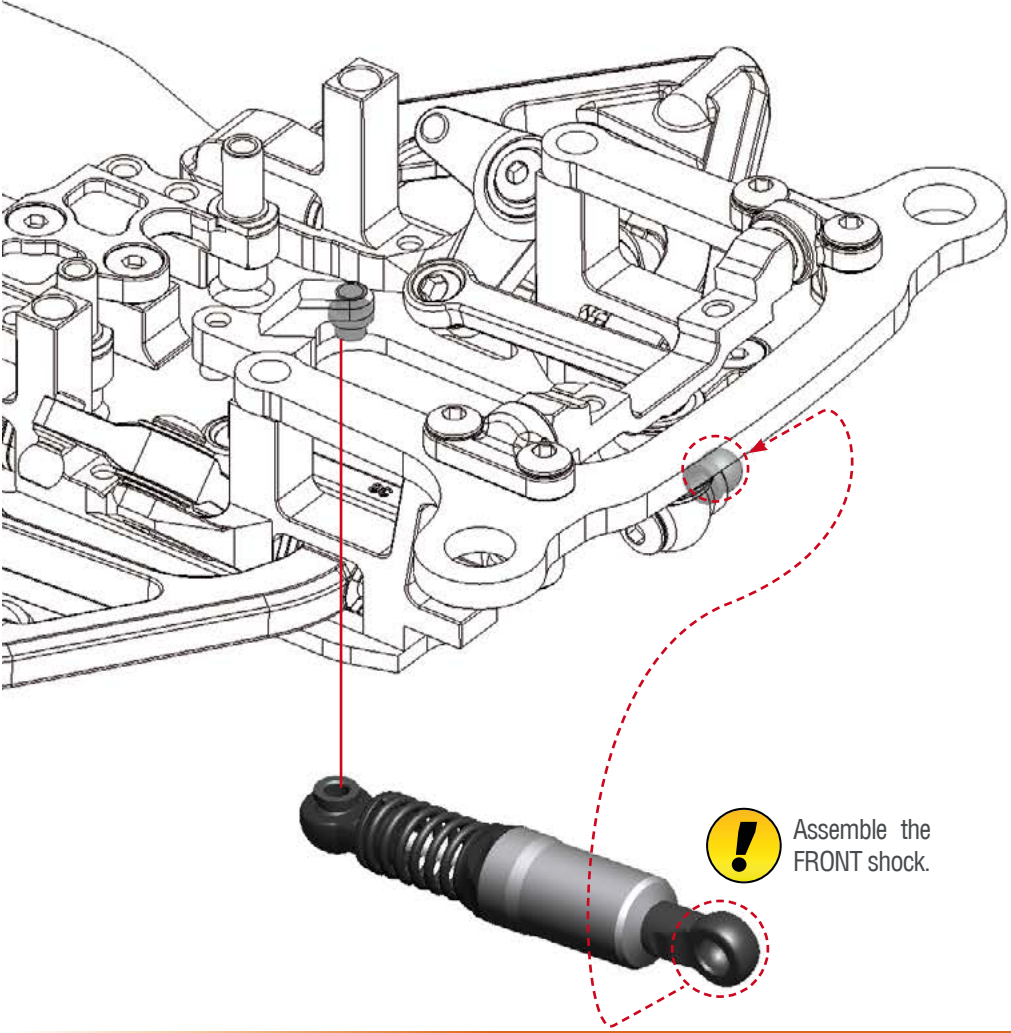

STEP 34

34.1

! Assemble the FRONT rolldamper.

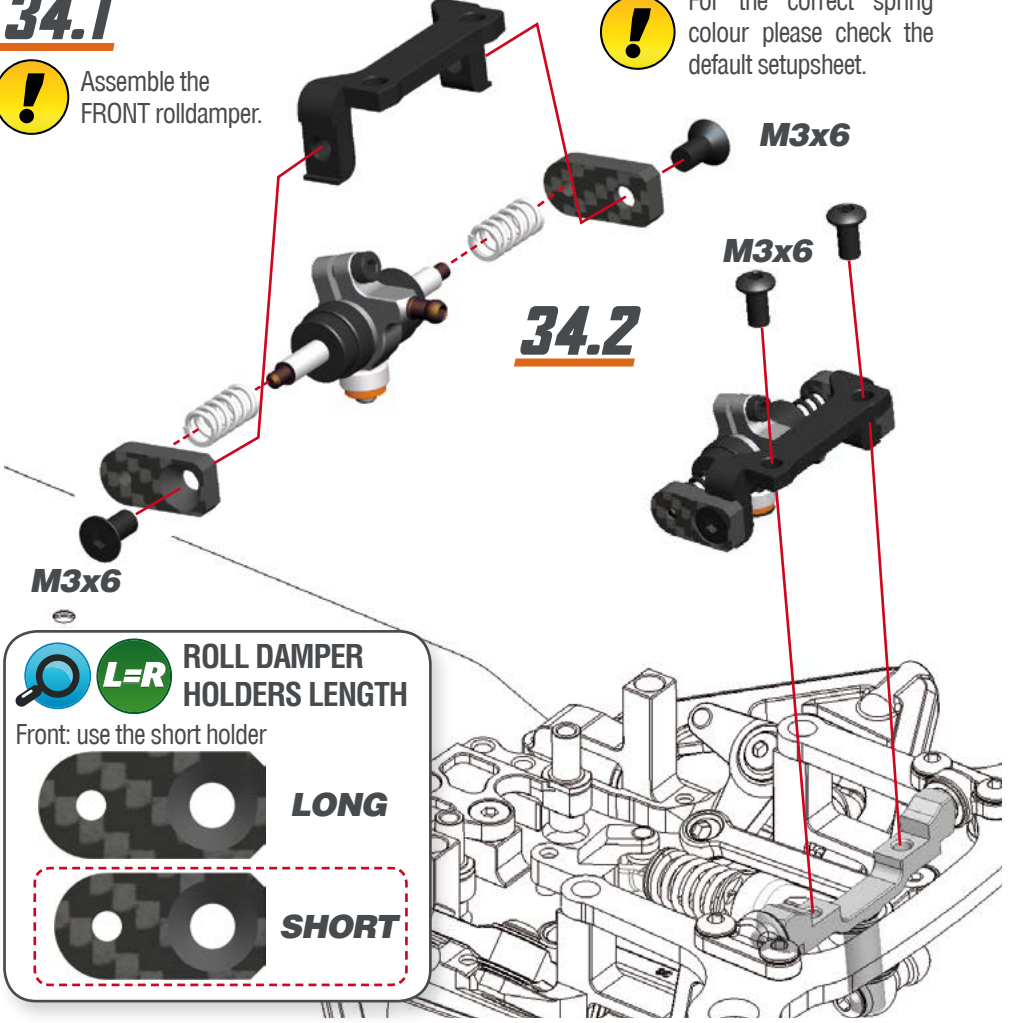

34.2

L=R ROLL DAMPER HOLDERS LENGTH
Front: use the short holder

LONG

SHORT

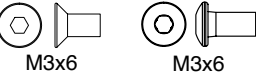

STEP 35 BAG 8

STEP 36

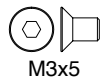
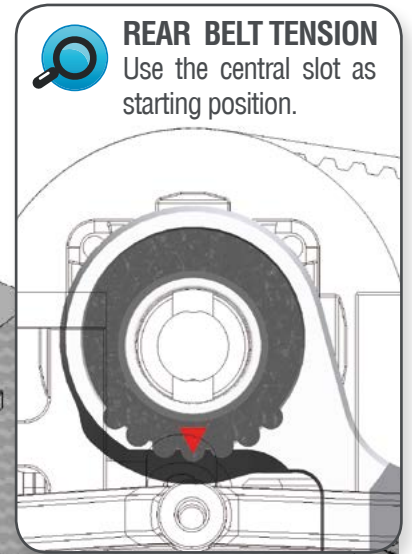
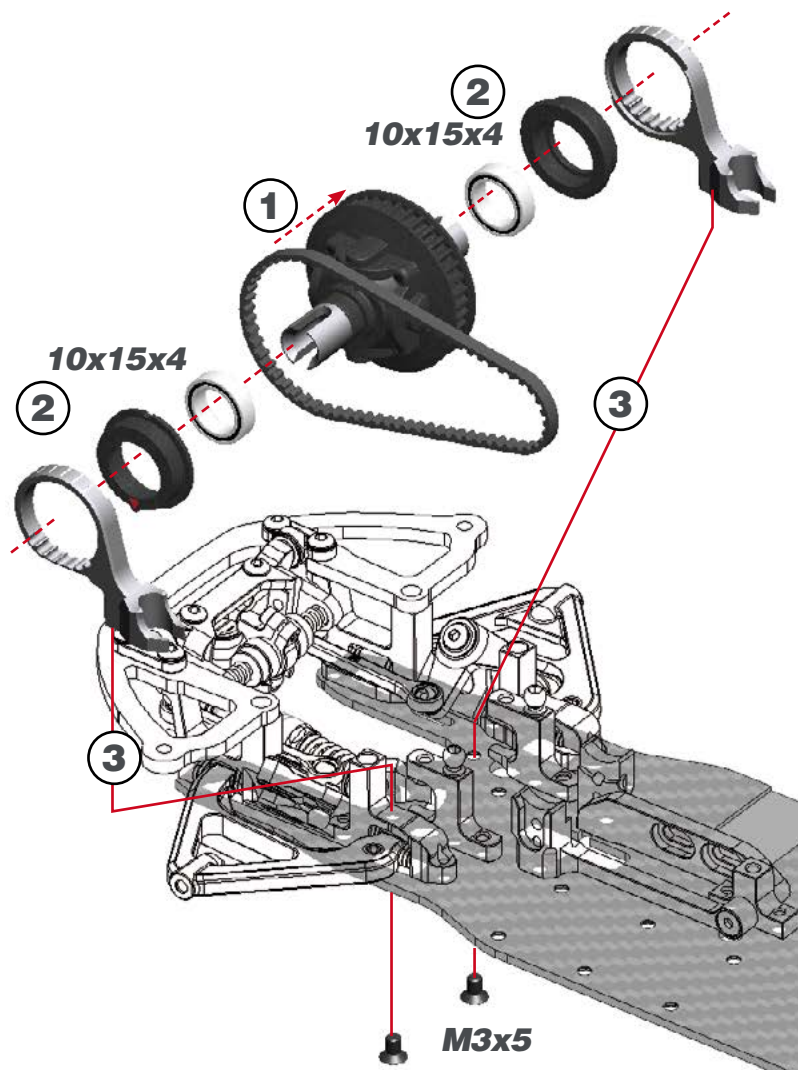
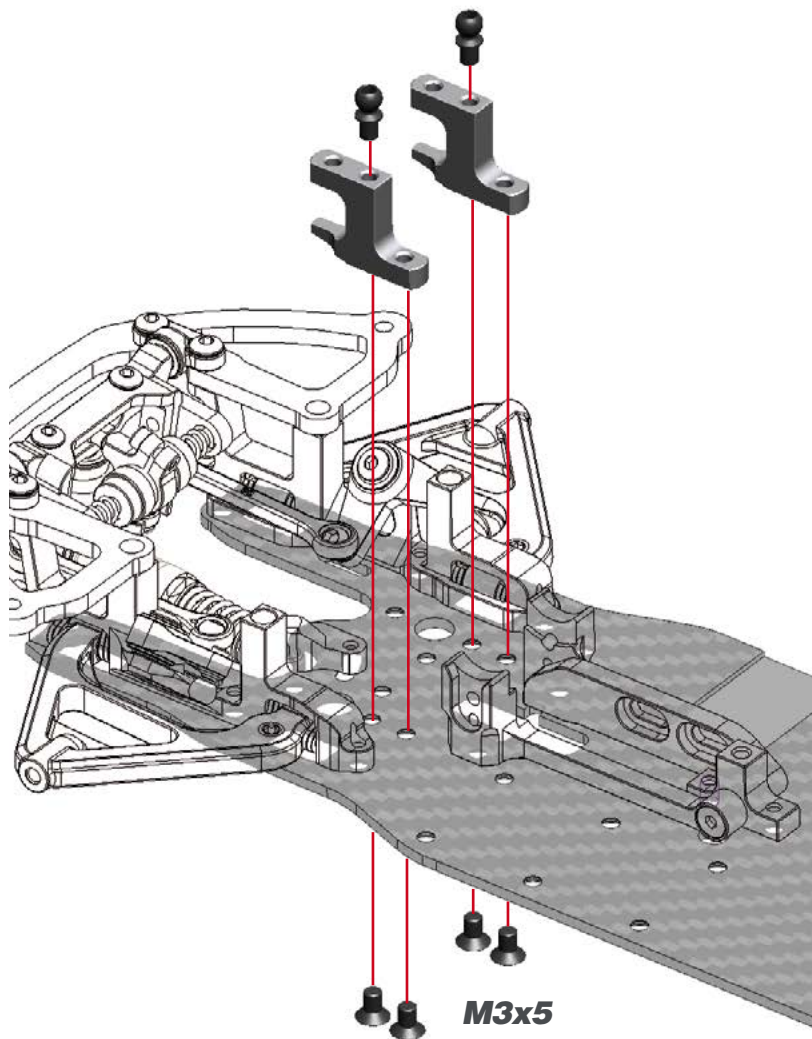

M3x5

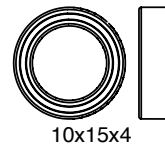

10x15x4



M3x5

STEP 37

STEP 38

37.1

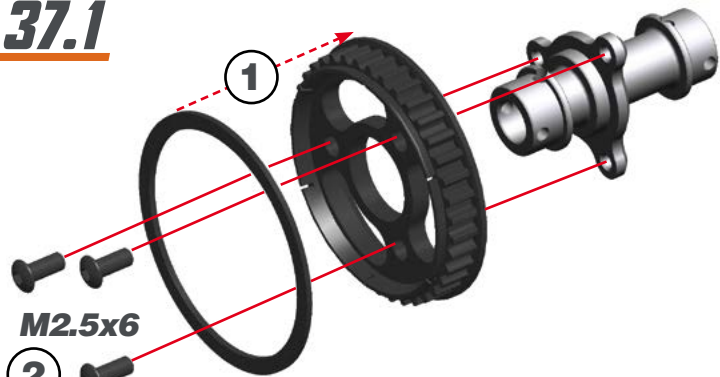

M2.5x6

2

37.2

Apply some grease on the pins to prevent them from falling out.

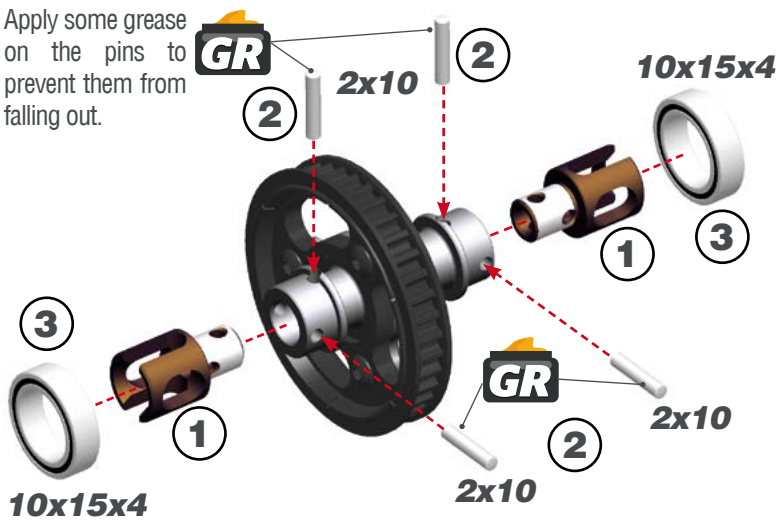

GR

2x10

10x15x4

2

2

1

3

GR

2x10

2x10

3

1

10x15x4

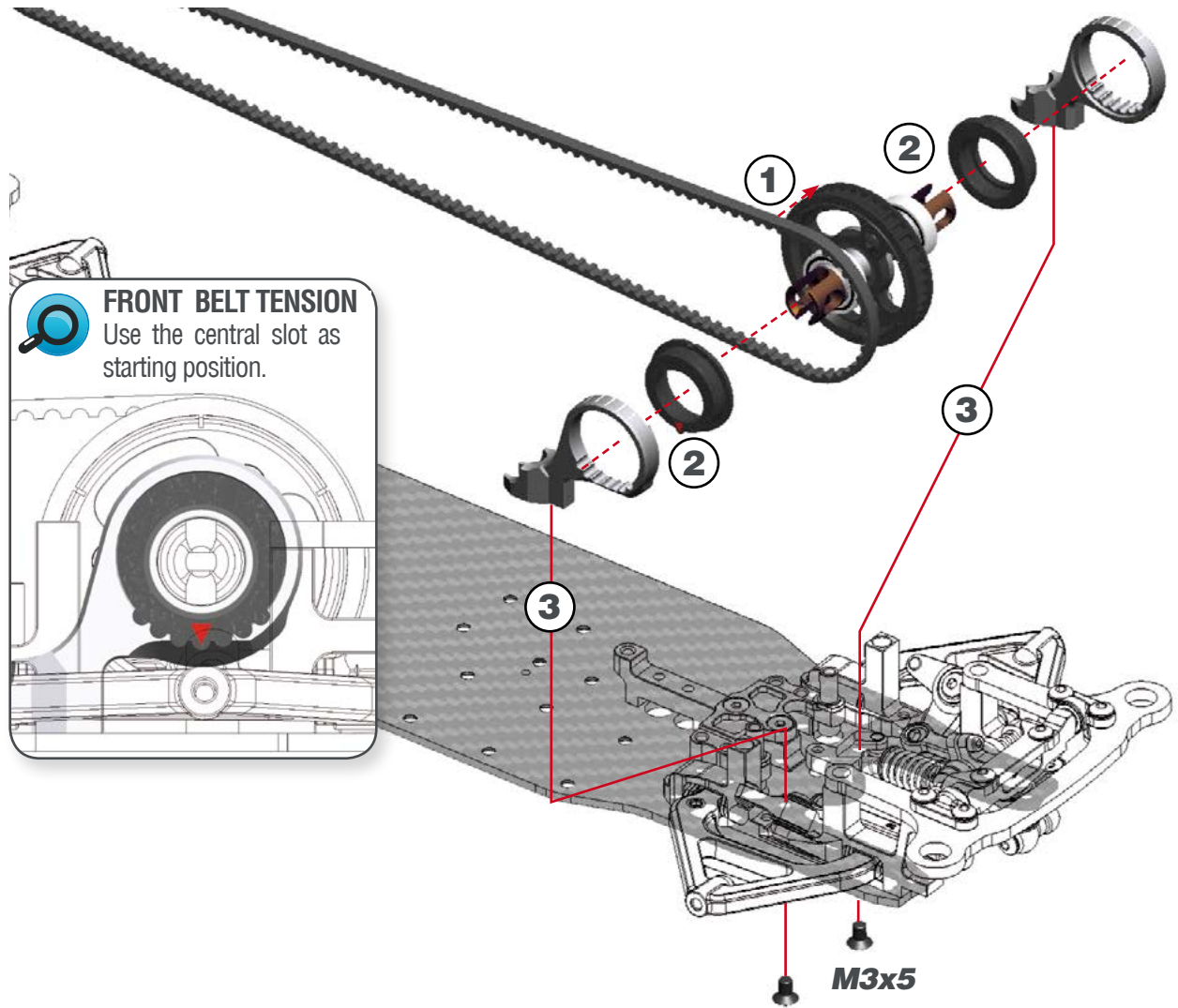

FRONT BELT TENSION
Use the central slot as starting position.

1

2

3

2

3

M3x5

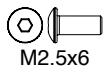

M2.5x6



2x10



10x15x4



M3x5

STEP 39

39.1

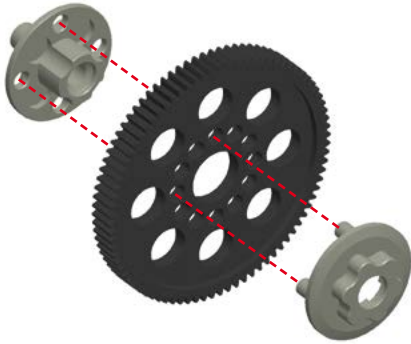

39.2

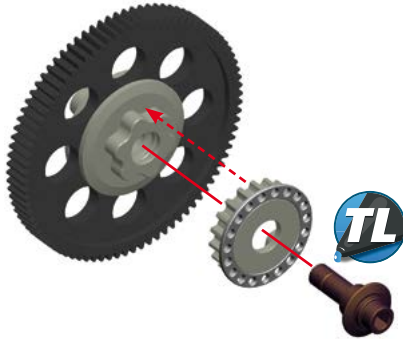

39.3

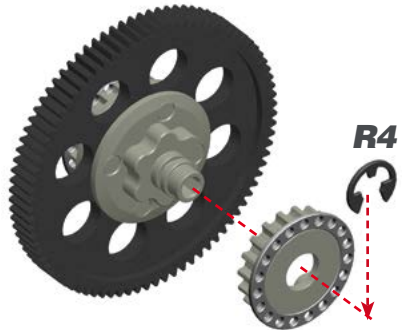

STEP 40

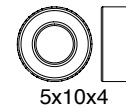
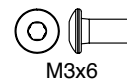
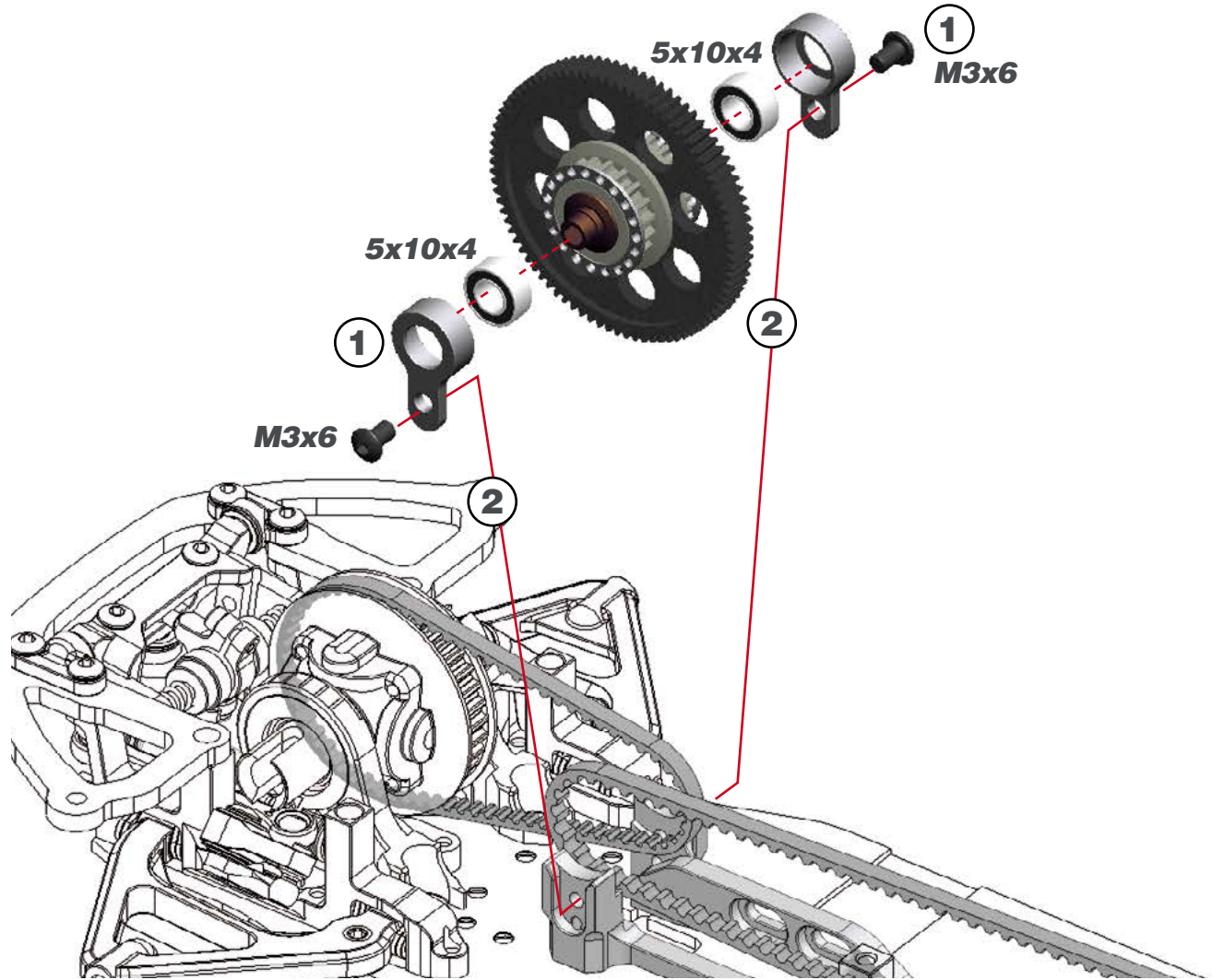

STEP 41

BAG 9

! Note the right orientation of the steering-levers.

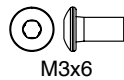
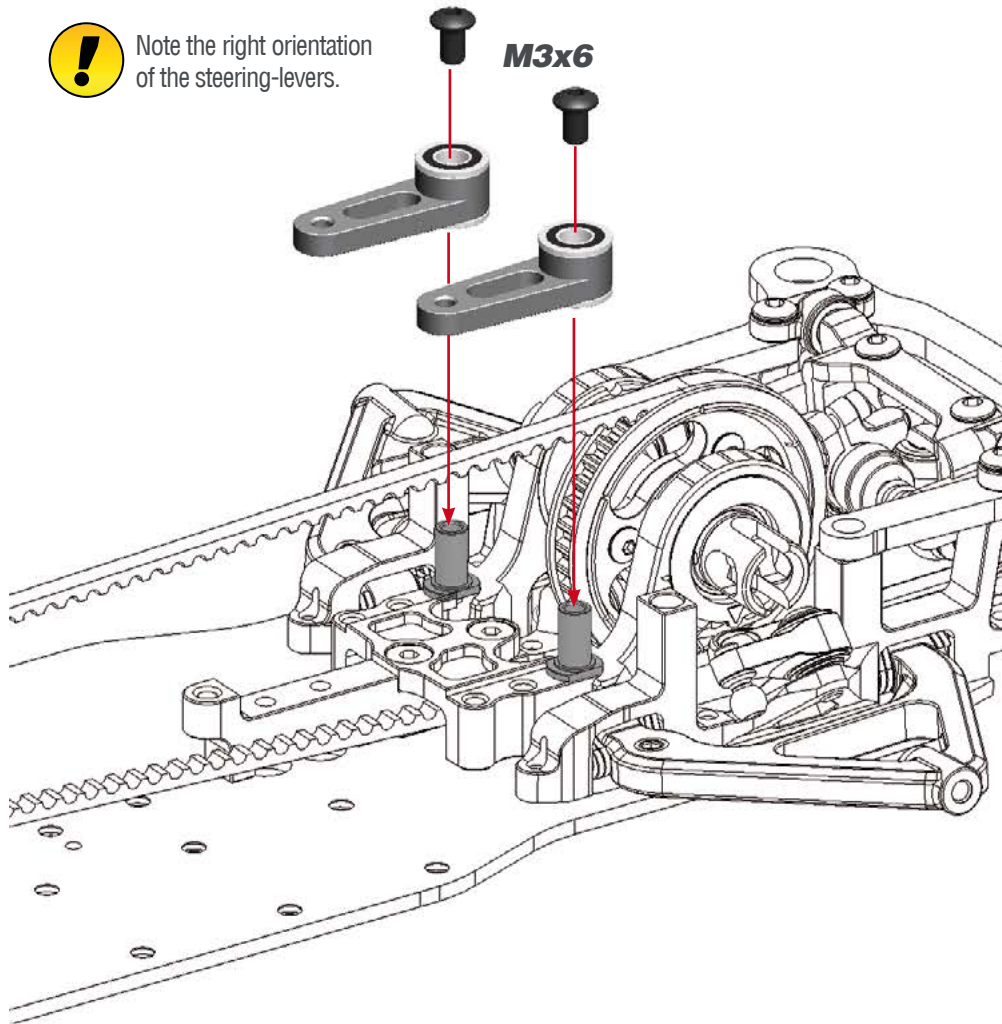

STEP 42

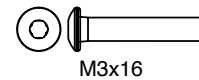
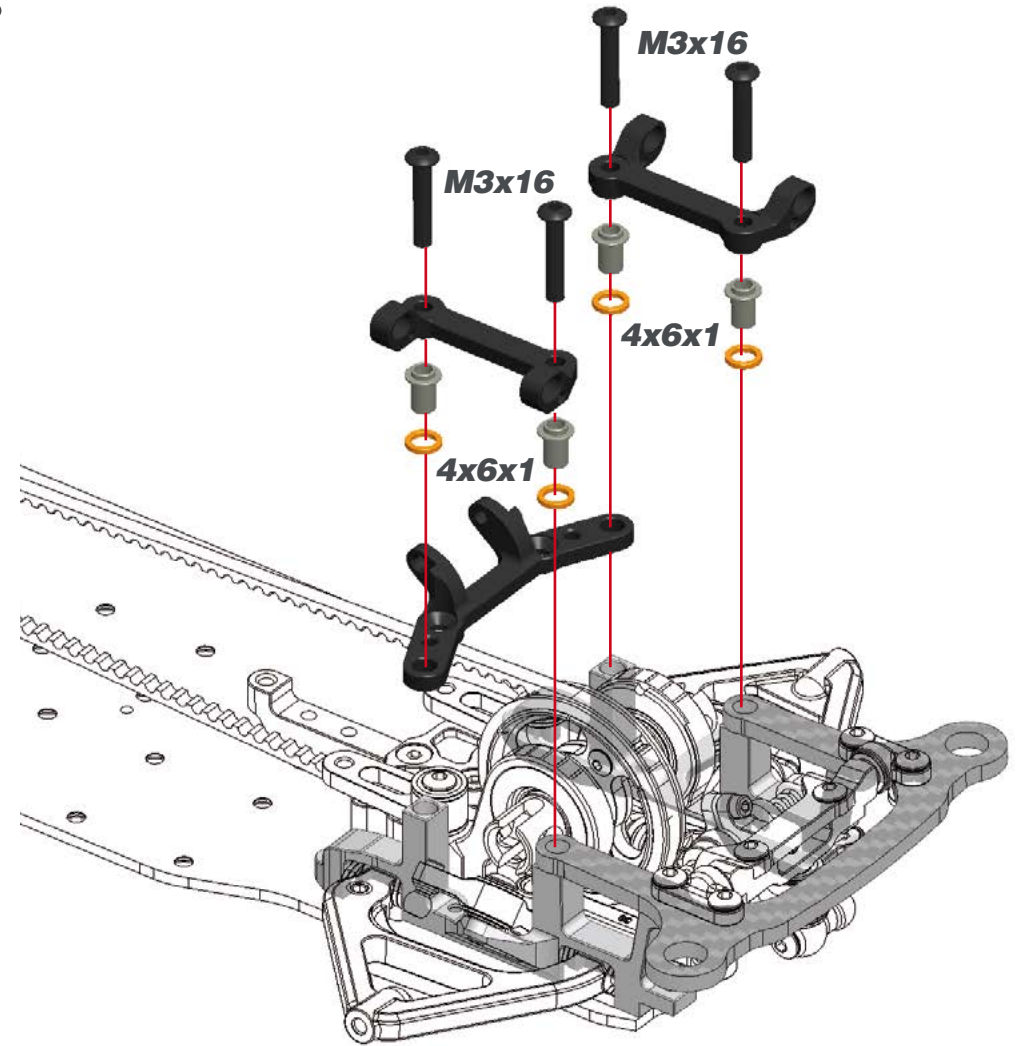

STEP 43 **BAG 18**

43.1

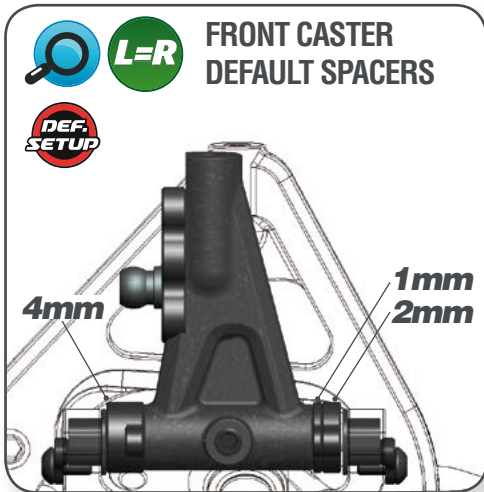
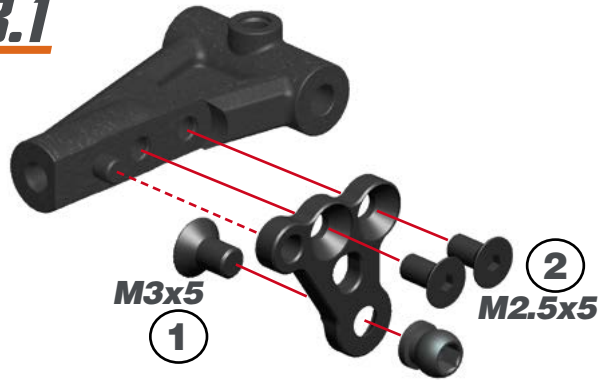

43.2

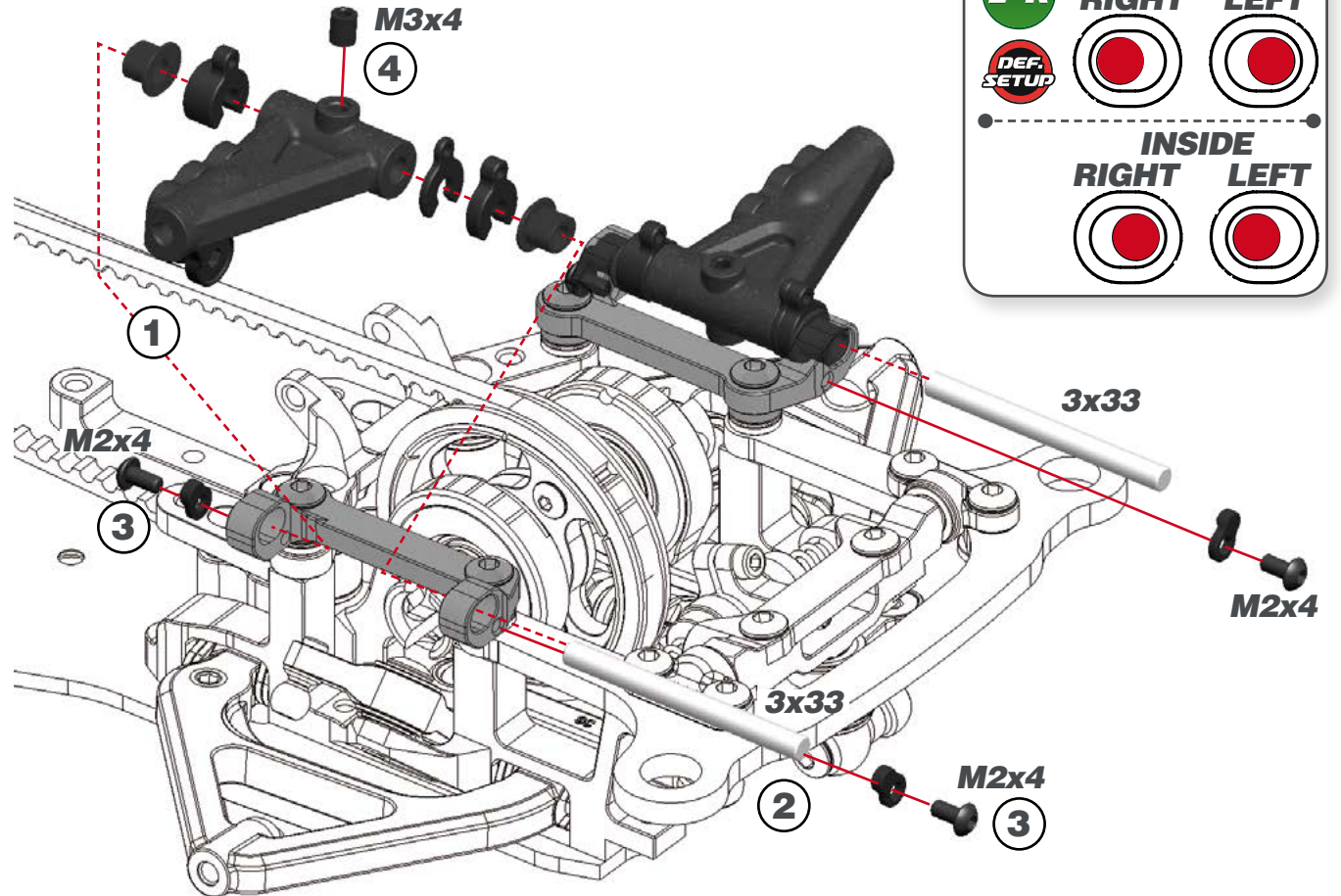

FRONT SUSPENSION
INSERTS CHART

L=R **OUTSIDE**
RIGHT LEFT

DEF. SETUP

INSIDE
RIGHT LEFT

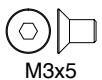

STEP 44



PULLROD LENGTH (mm)



Included are 5 lengths of composite pullrods. If ride height can not be adjusted enough using the excentric holder for the heavedamper, use different pullrod length. For more ride height, use shorter pullrod.

Make sure to use same length Left and Right side.

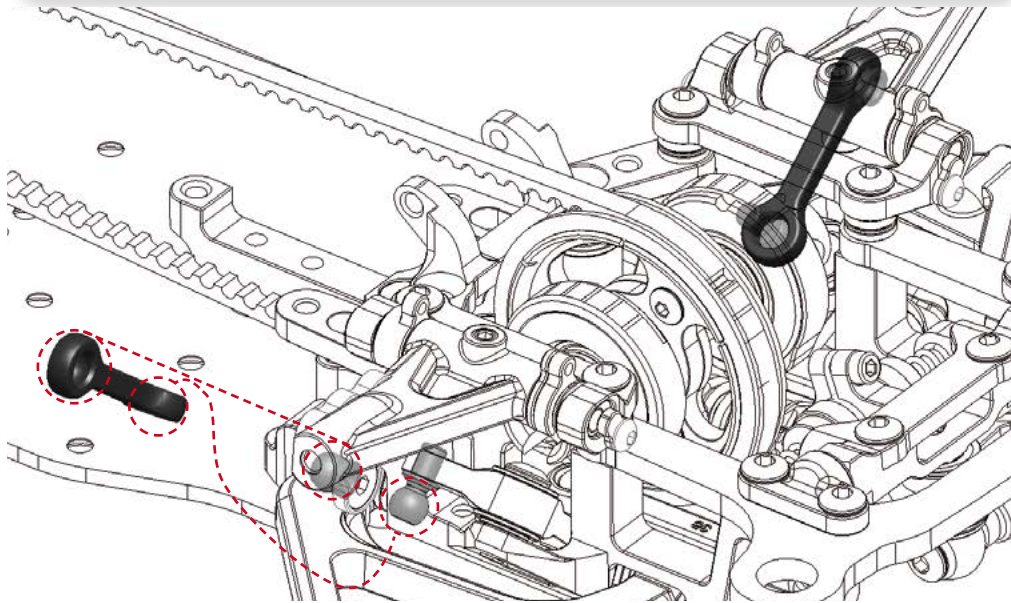

STEP 45

45.1

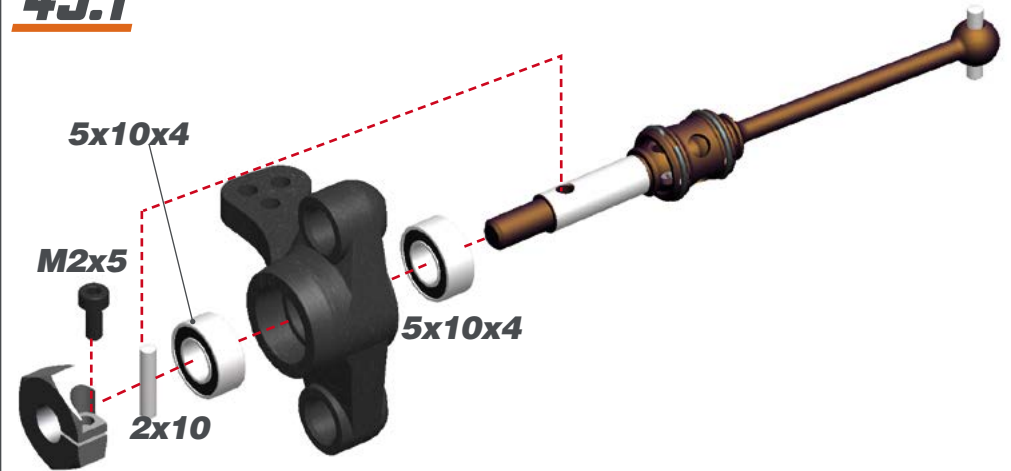

45.2



Do not overtighten the nuts. The pivotballs must move freely.

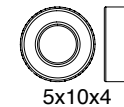
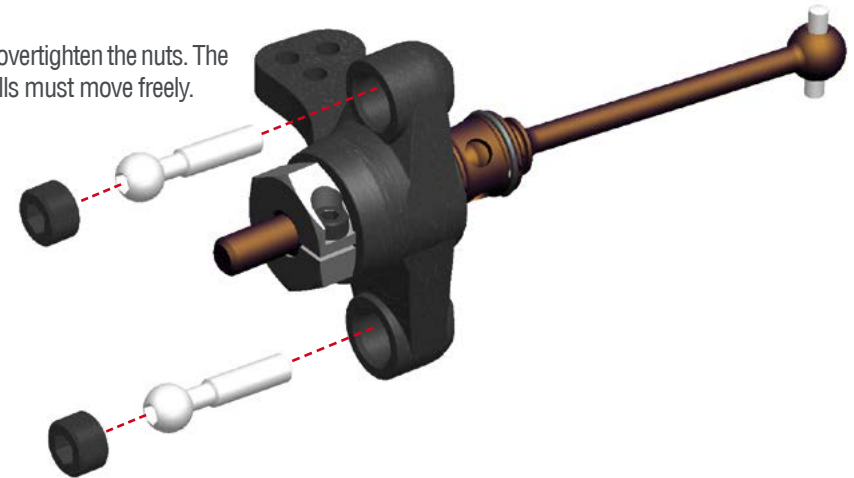

STEP 46

FRONT CAMBER AND TRACK WIDTH

DEF. SETUP

L=R

1.8 mm

2 mm

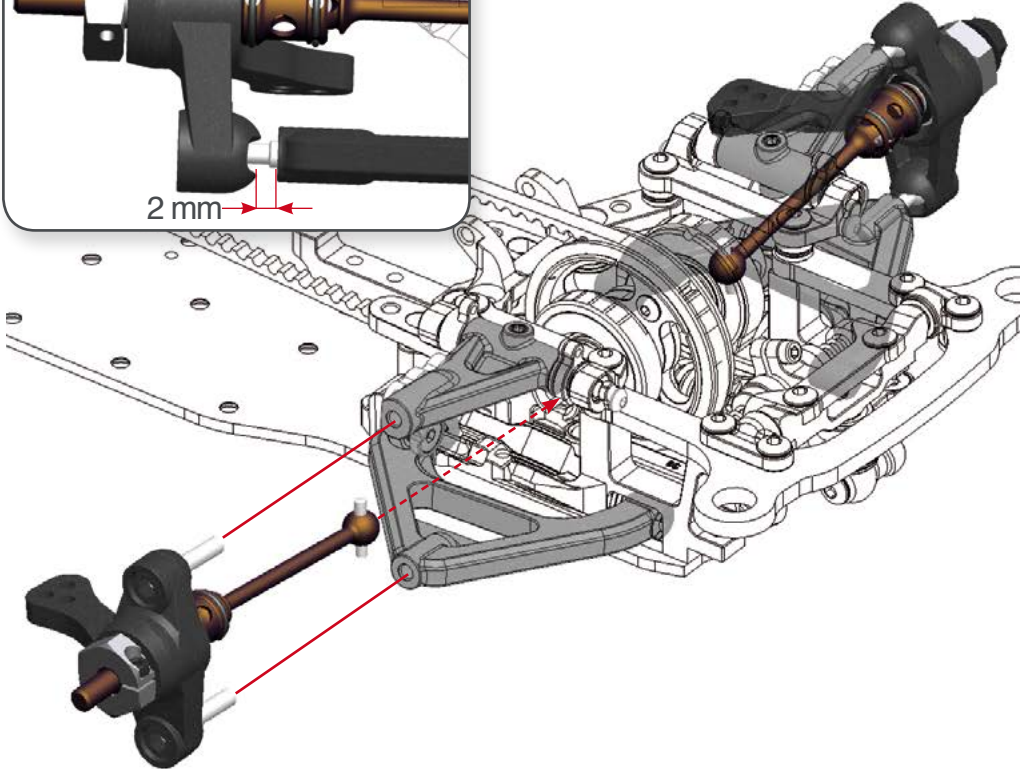

STEP 47 **BAG 11**

47.1

M3x5

M3x6

M3x5

DEF. SETUP

ACKERMANN INNER POSITION

47.2

M3x6

M3x6

3x5x0.3

- M3x5
- M3x6
- M3x6
- 3x5x0.3

STEP 48

48.1

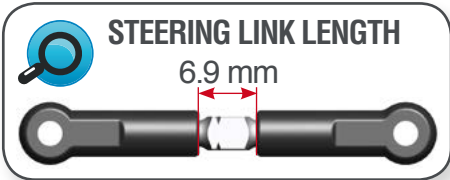
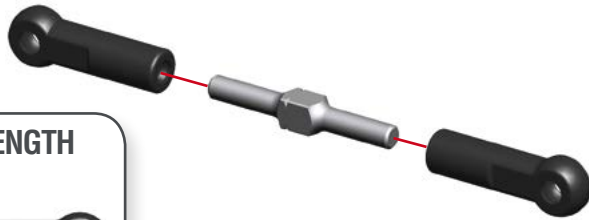

48.2

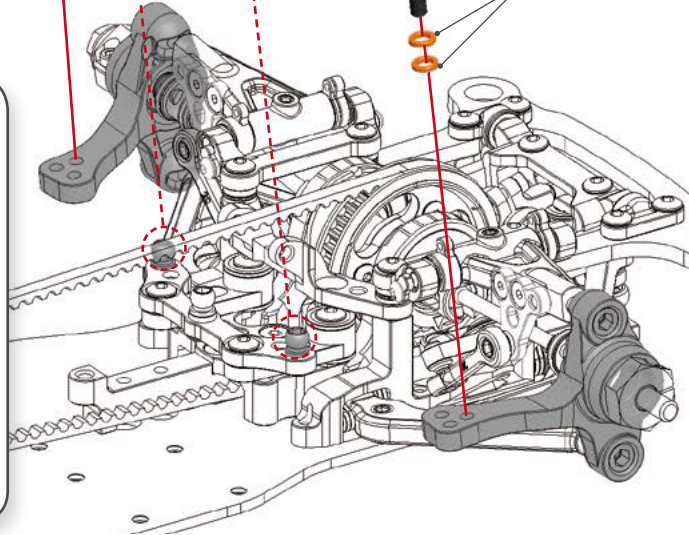
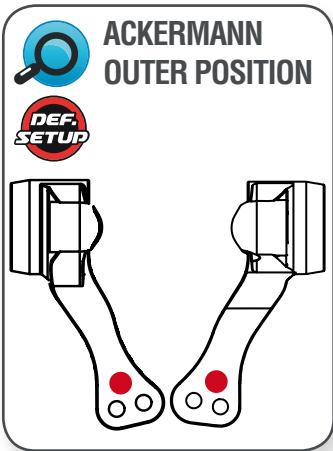

STEP 49

49.1

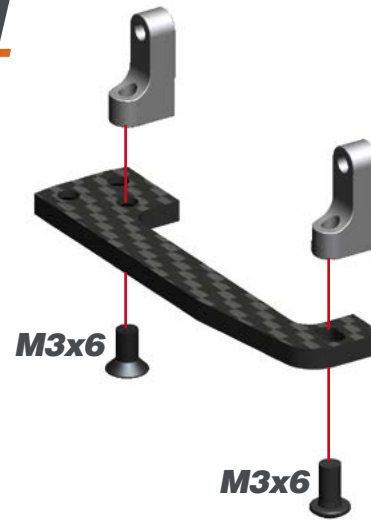

49.2

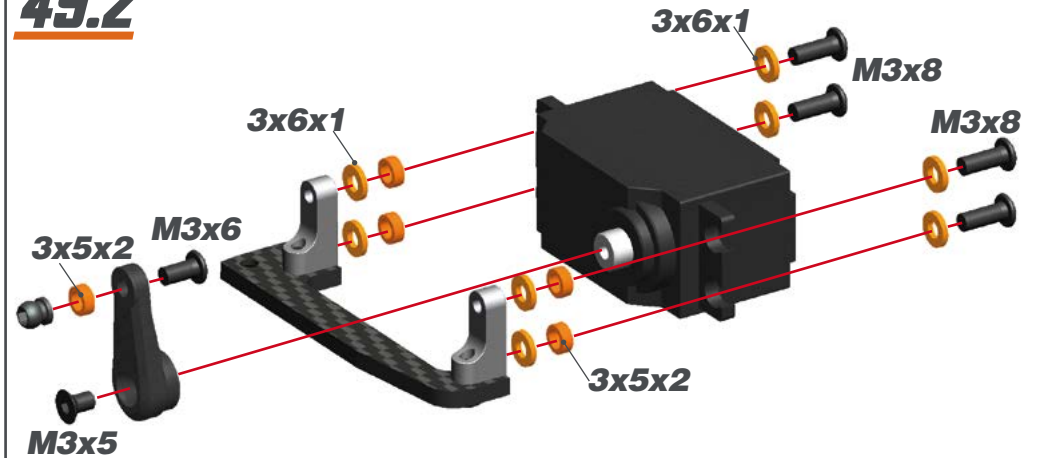

STEP 50

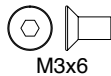
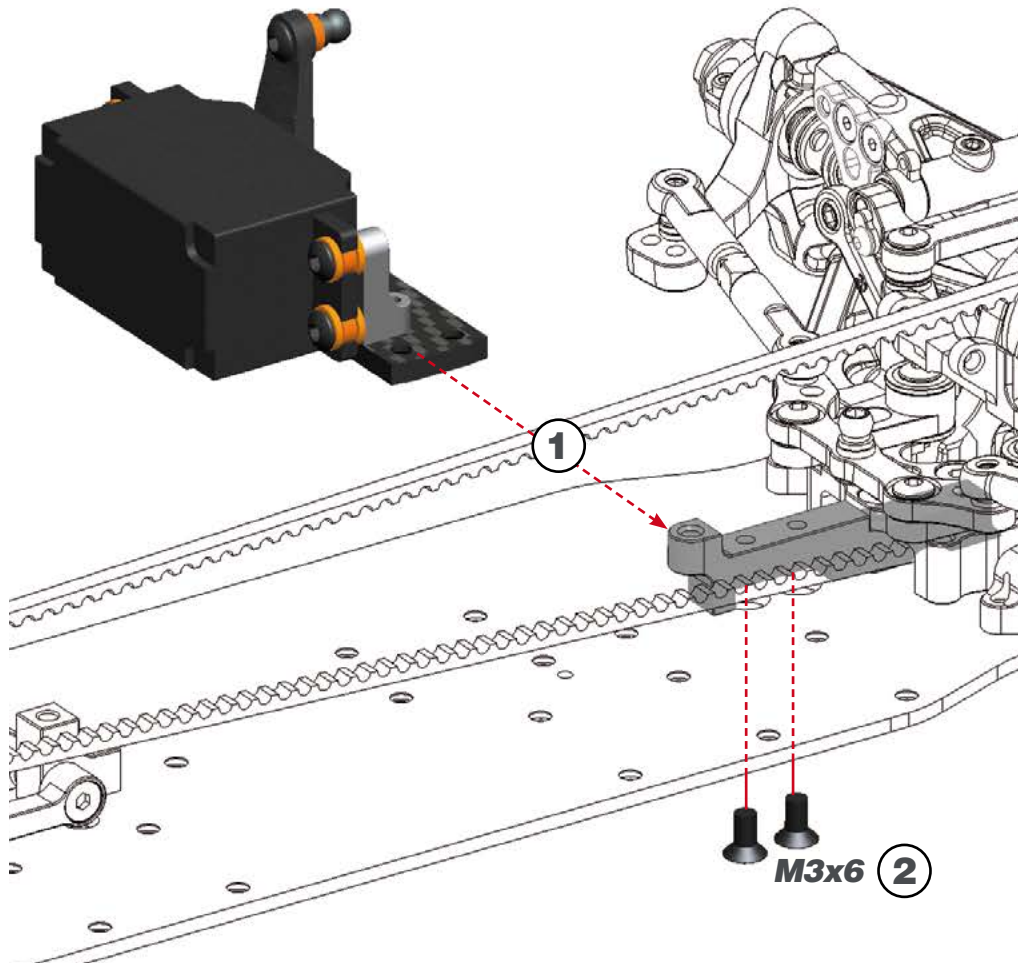

STEP 51

51.1

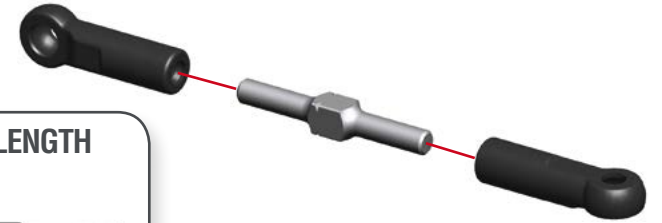
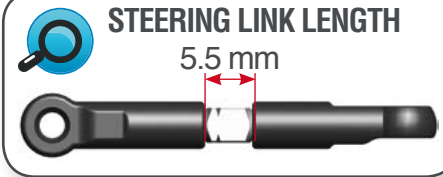

51.2

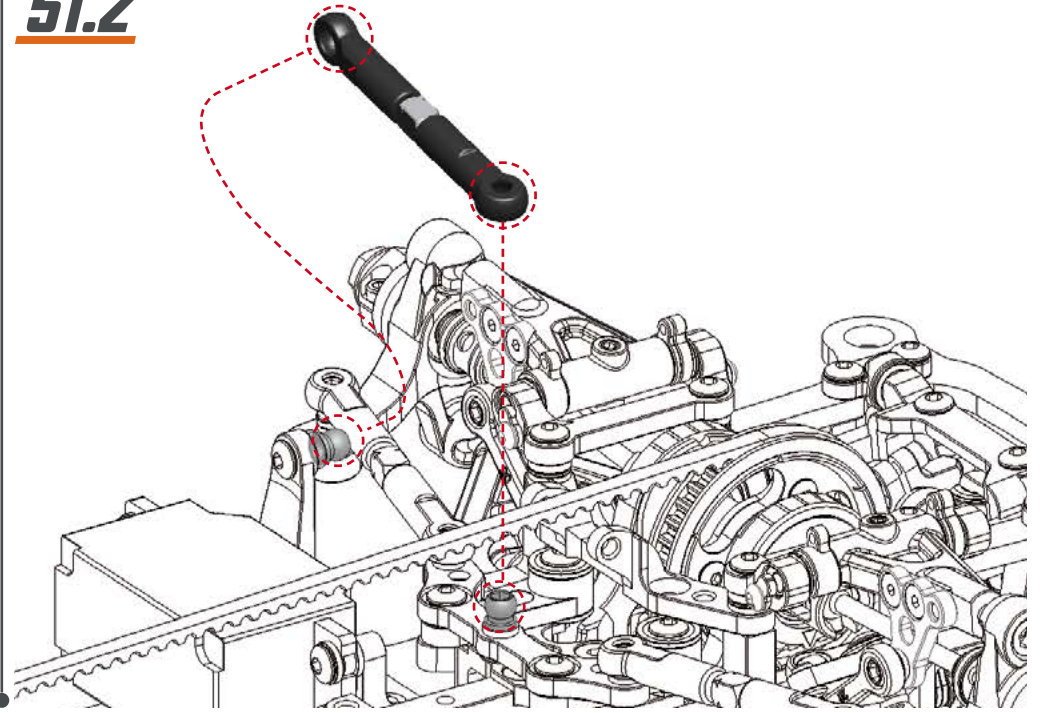

STEP 52 BAG 12

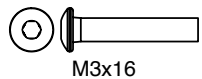
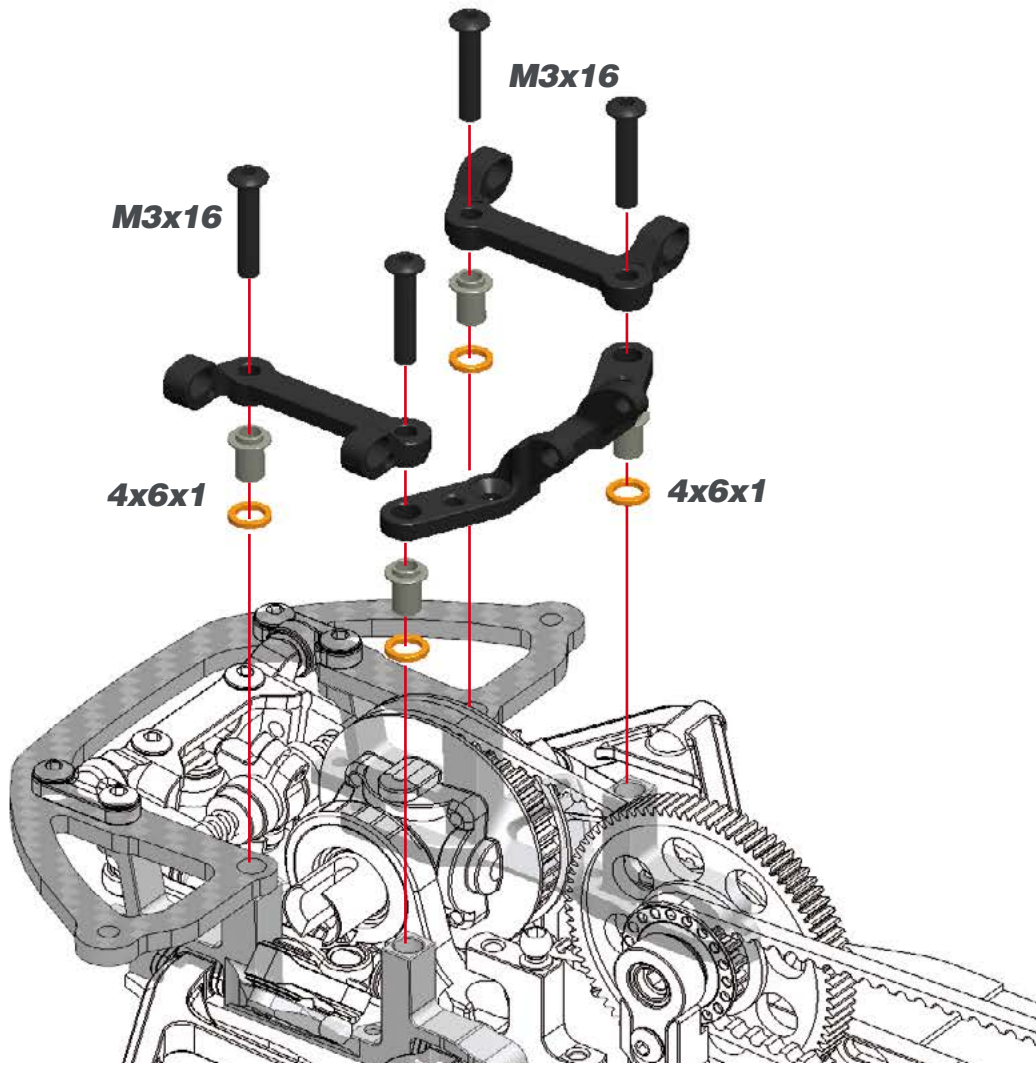

M3x16



3x5x1



4x6x1

STEP 53

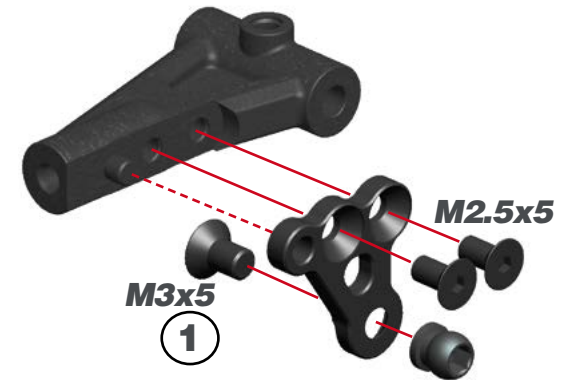

M3x5



M2.5x5

STEP 54

REAR WISHBONE
DEFAULT SPACERS

L=R

DEF. SETUP

2mm
1mm
4mm

REAR SUSPENSION
INSERTS CHART

L=R

DEF. SETUP

OUTSIDE
RIGHT LEFT

INSIDE
RIGHT LEFT

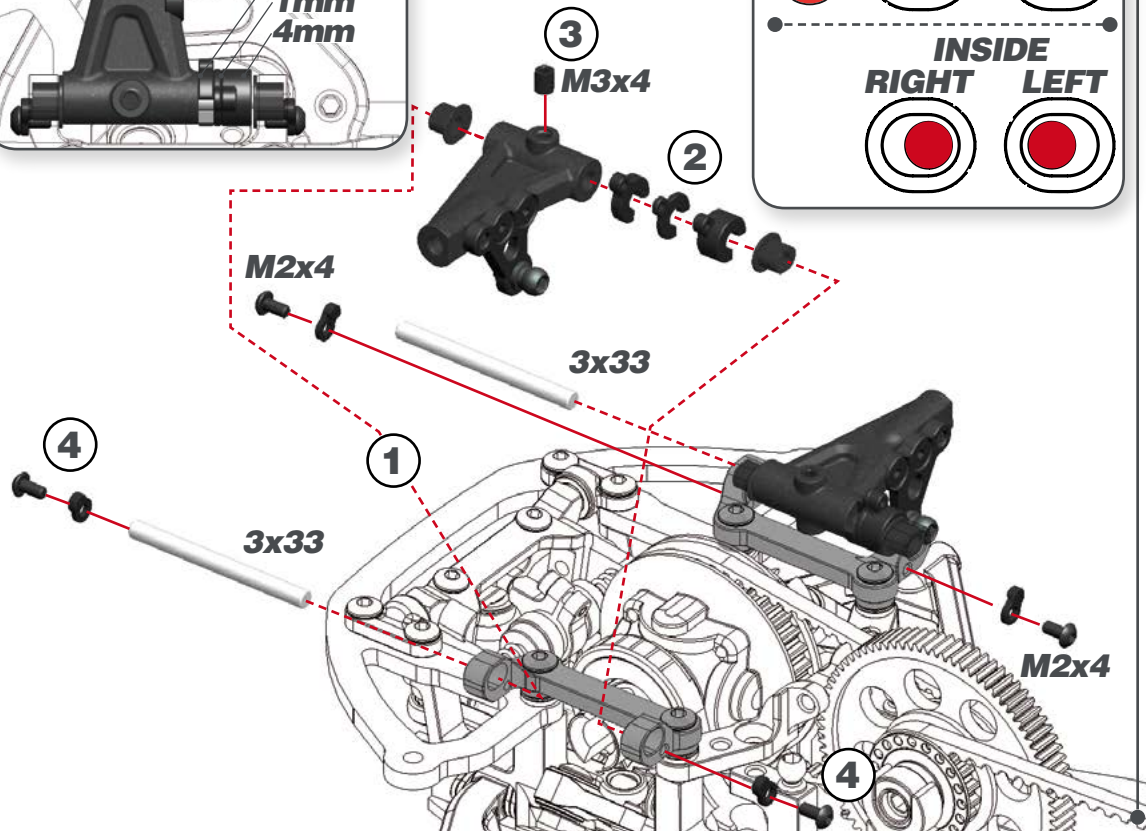

STEP 55

PULLROD
LENGTH (mm)

L=R

DEF. SETUP

Included are 5 lengths of composite pullrods. If ride height can not be adjusted enough using the eccentric holder for the heavedamper, use different pullrod length. For more ride height, use shorter pullrod.

21 20.5 20 19.5 19

Make sure to use same length Left and Right side.

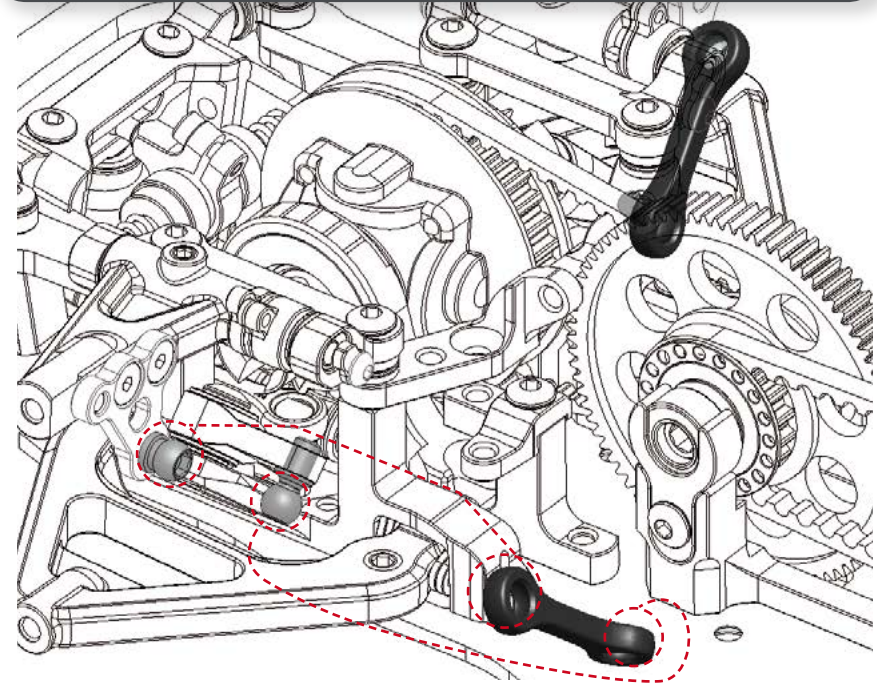

STEP 56 **BAG 13**

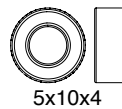
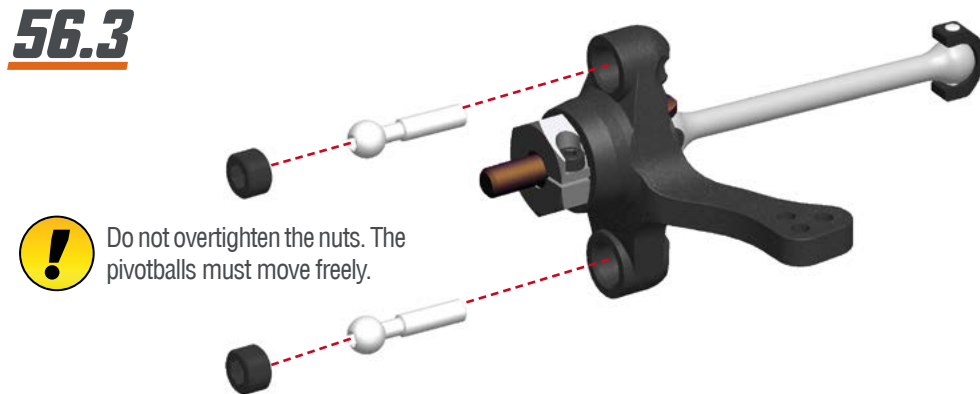
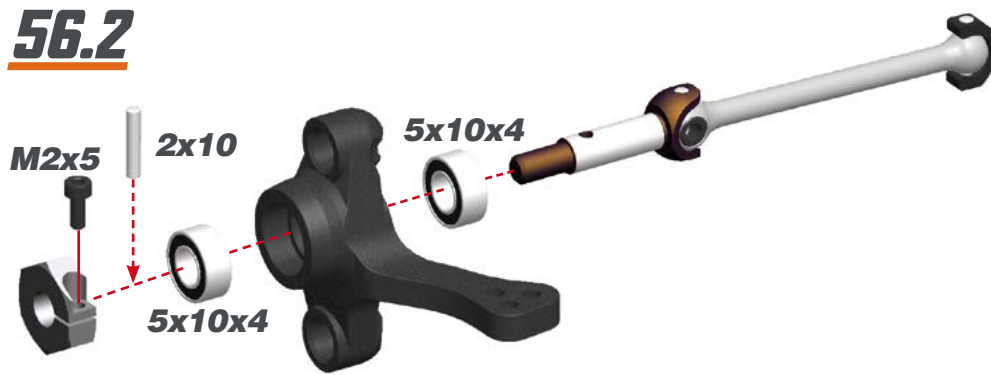
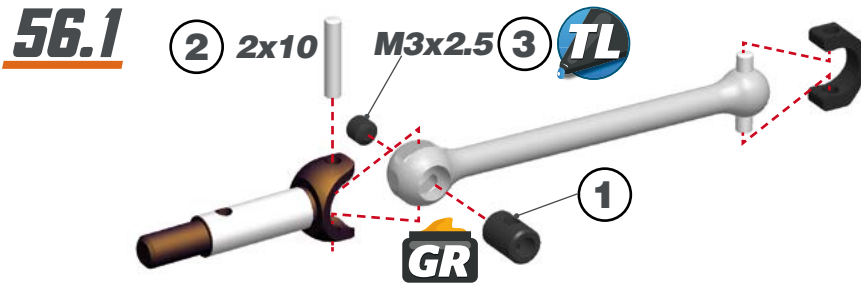

STEP 57

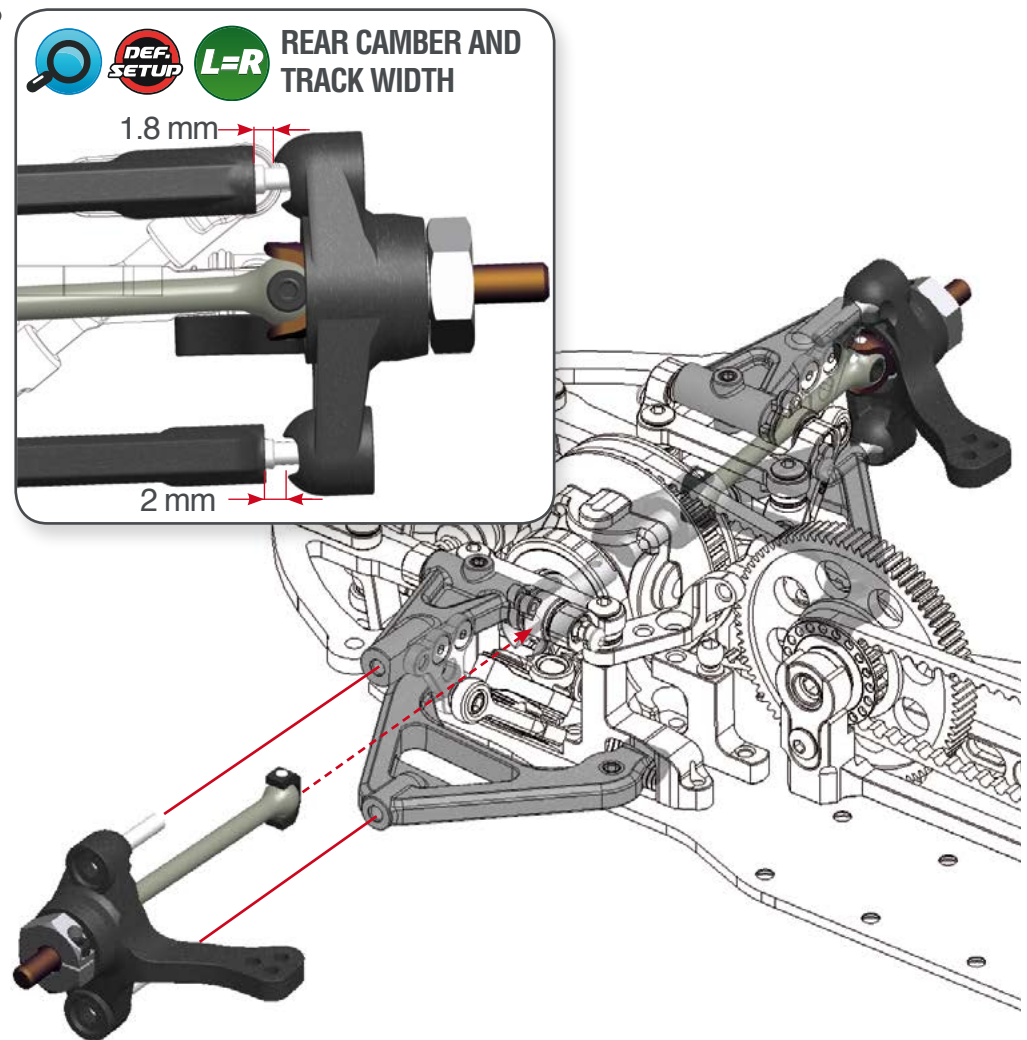

STEP 58

58.1

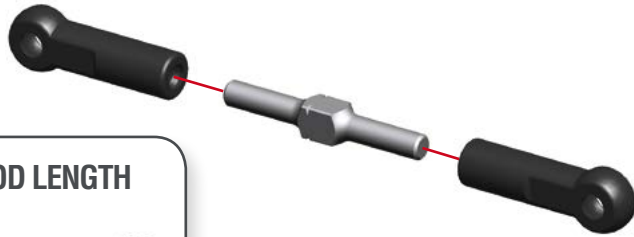

REAR TRACKROD LENGTH
10 mm

58.2

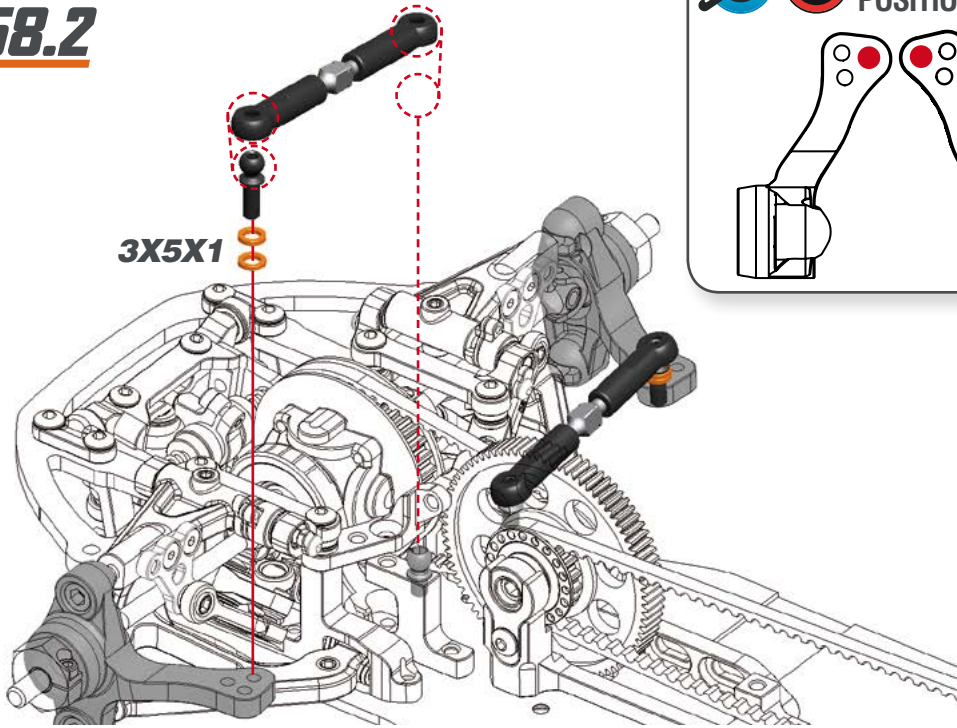

DEF. SETUP UPRIGHT LINKAGE POSITION



STEP 59 BAG 14

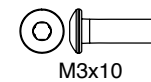
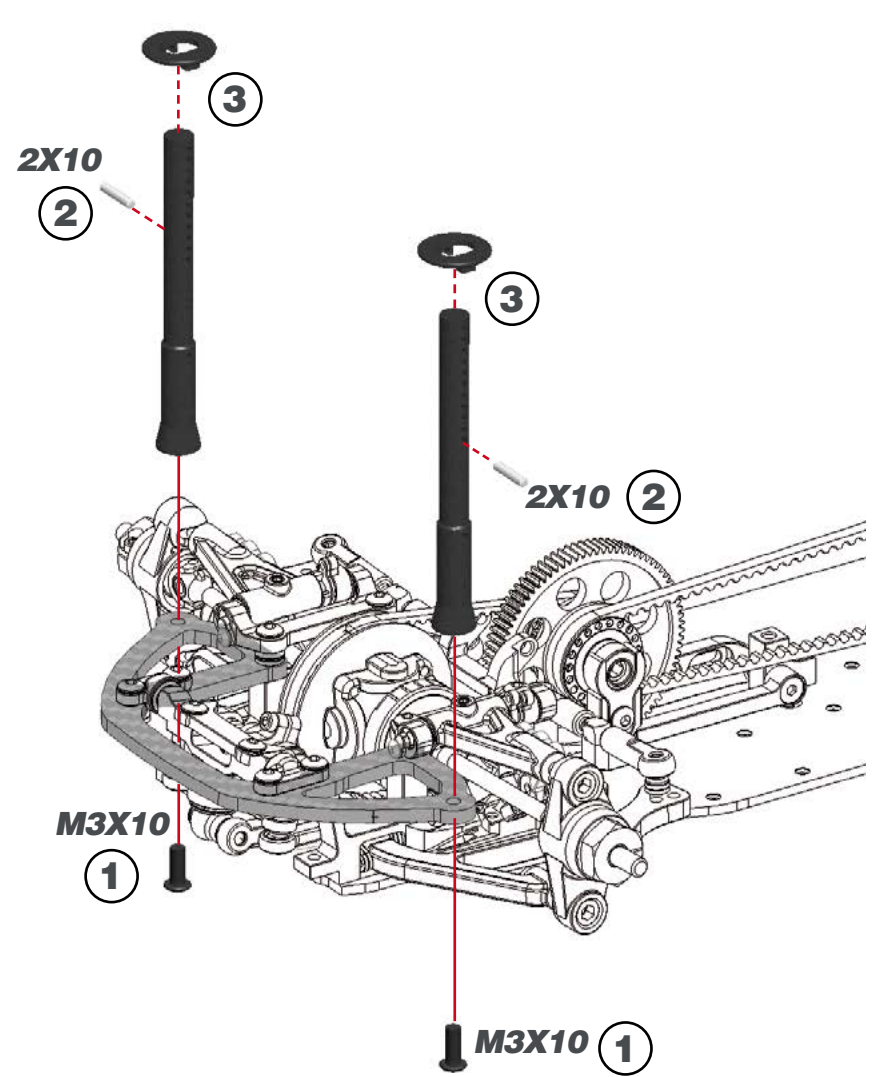

STEP 60

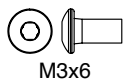
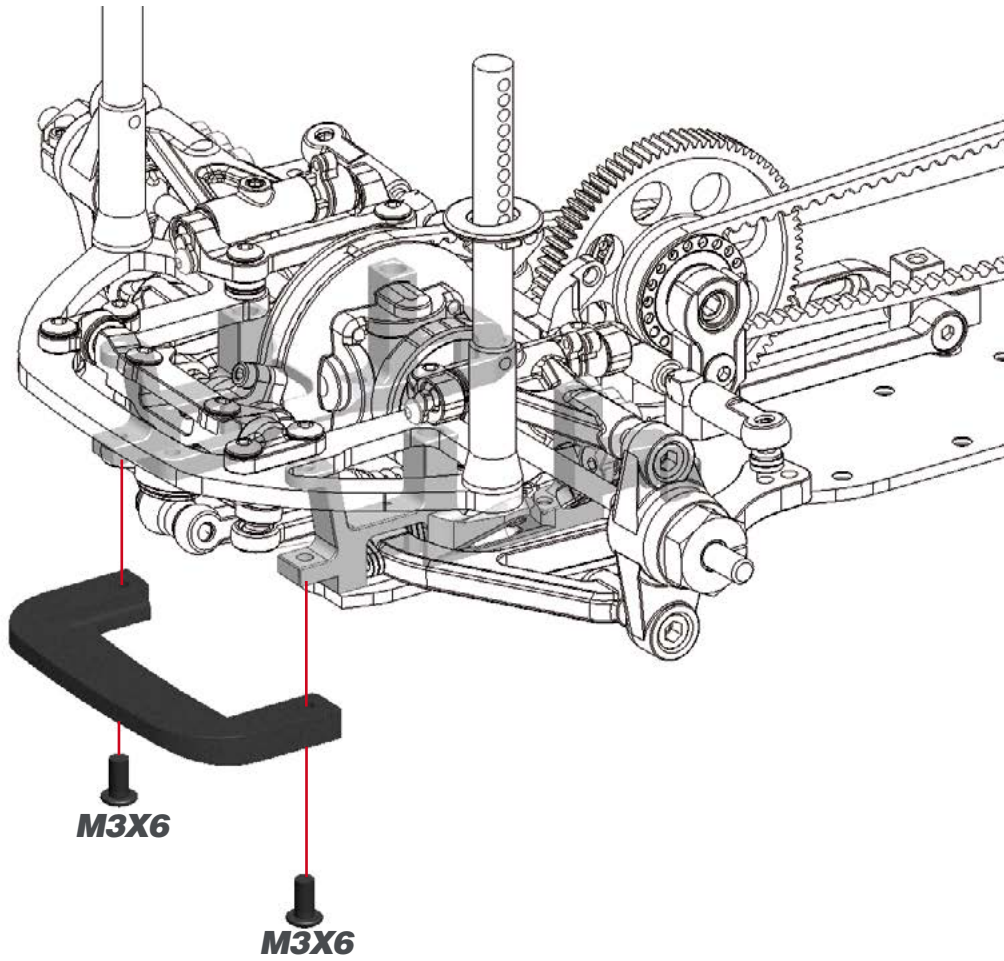

STEP 61

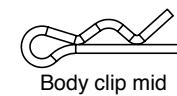
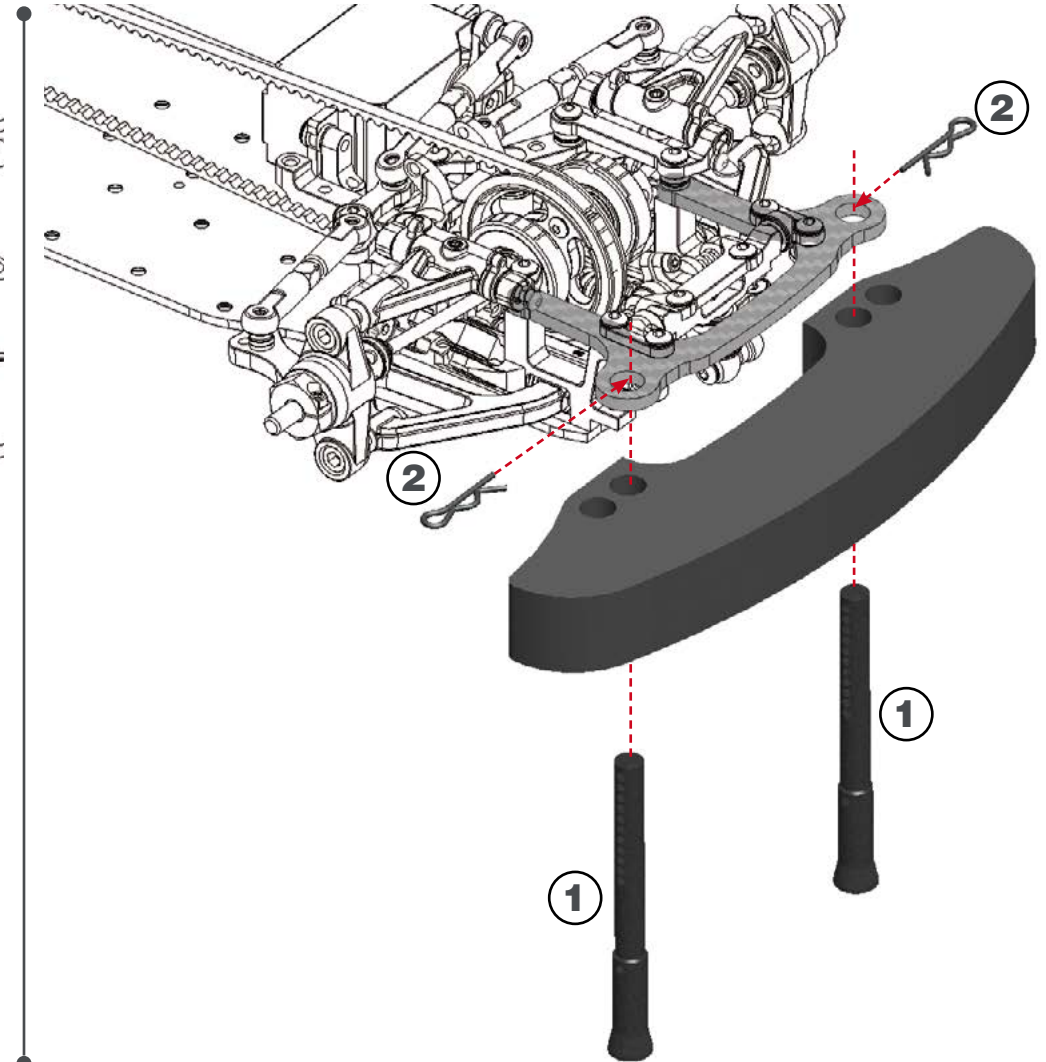

STEP 62

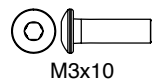
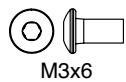
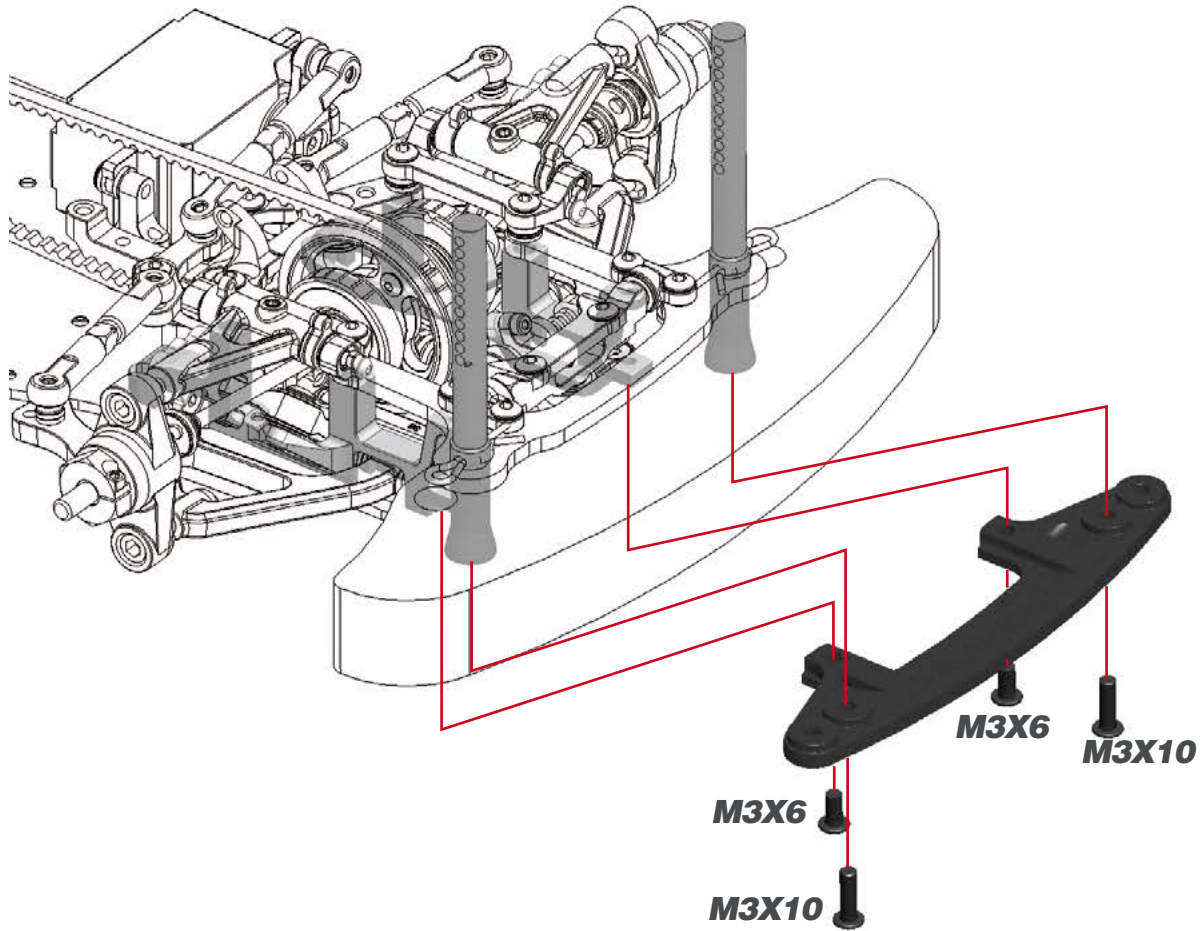

STEP 63

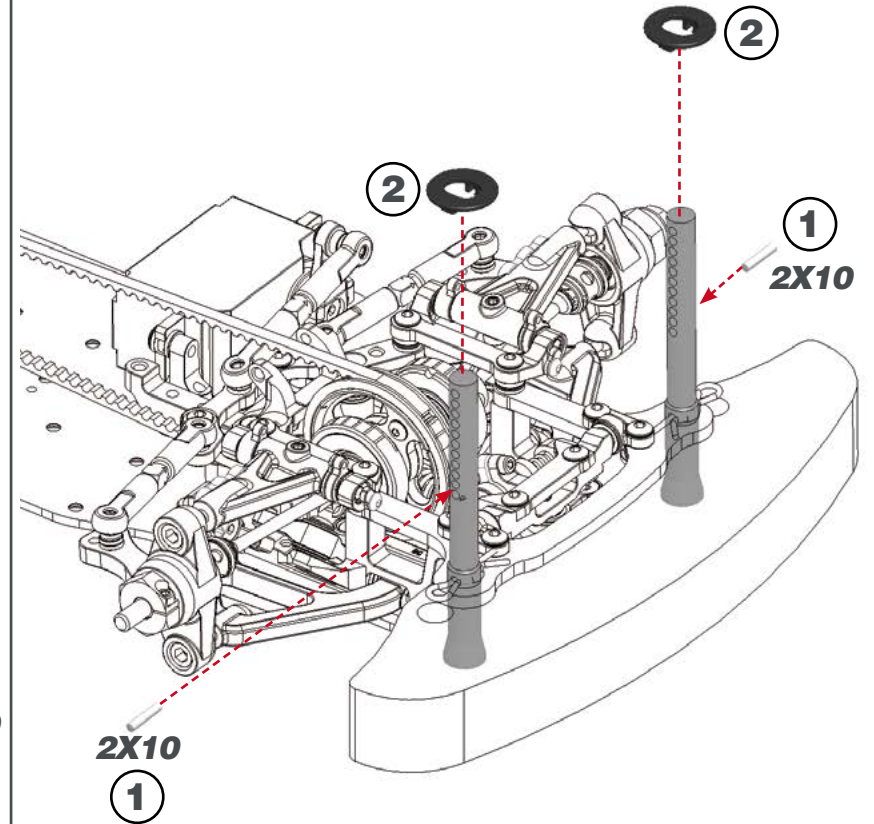

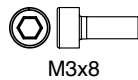
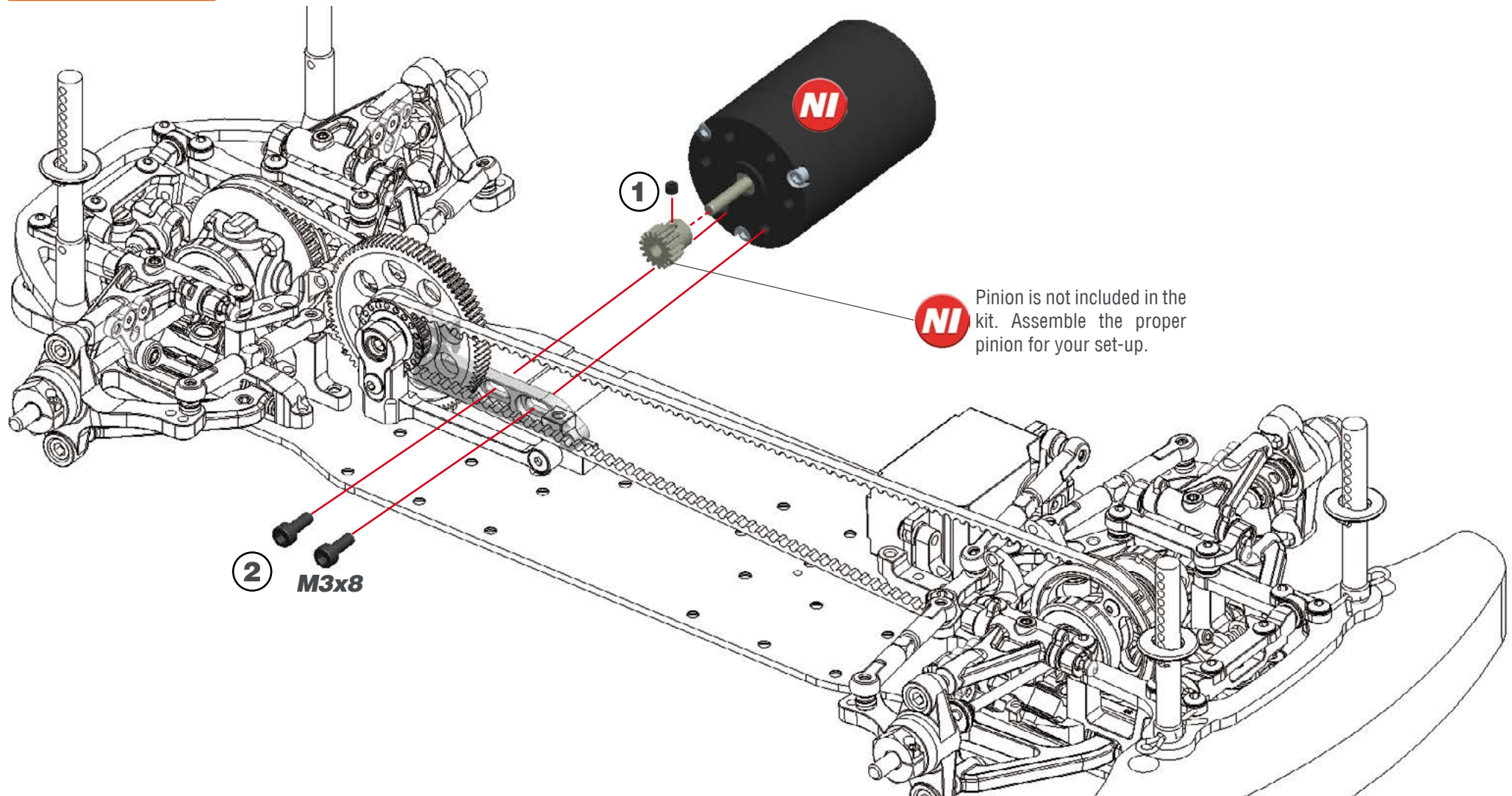
STEP 64 **BAG 15**

STEP 65

! Use double sided tape to mount the ESC, RX and the transponder to the chassis.

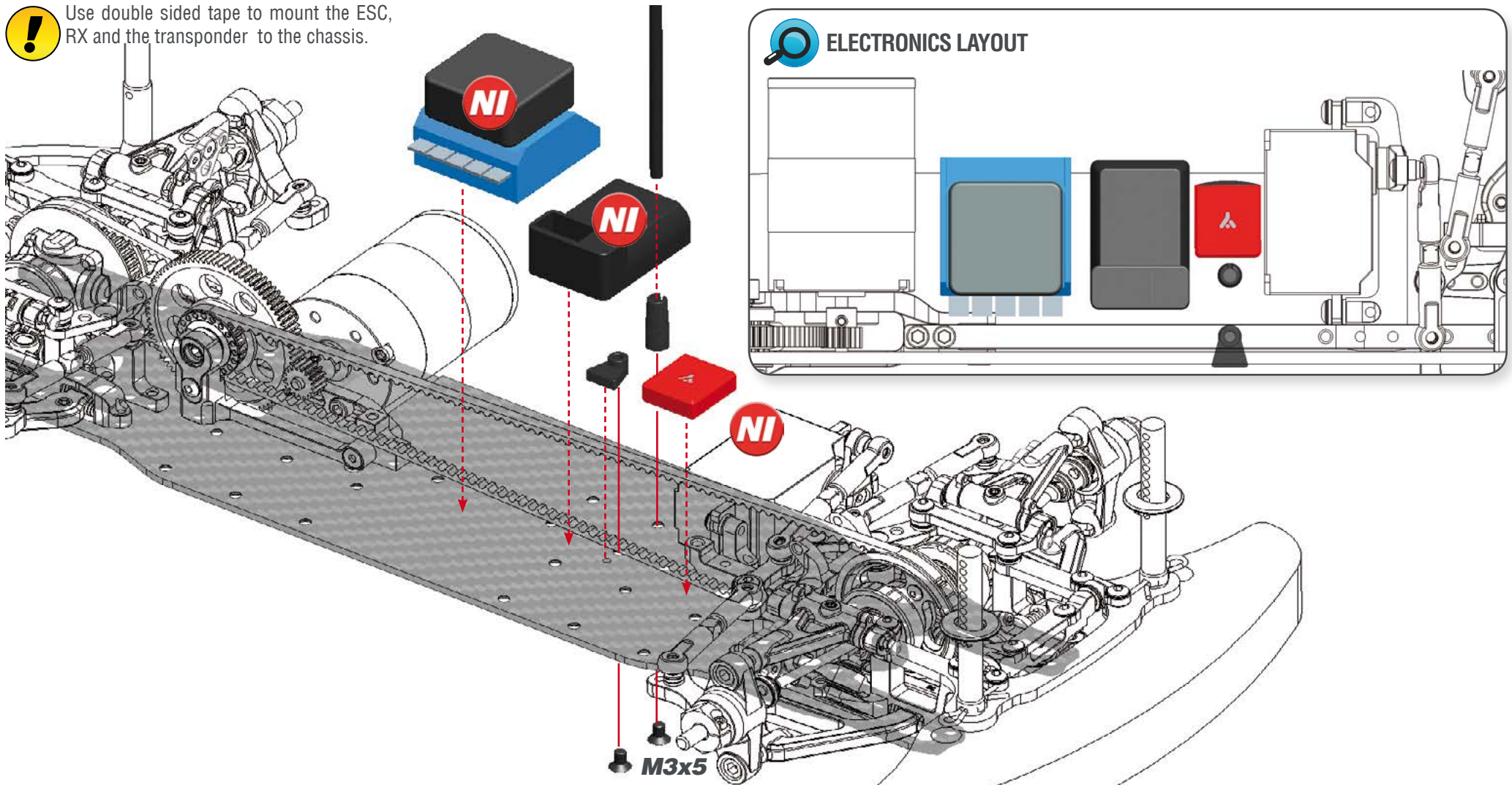

STEP 66

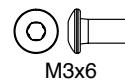
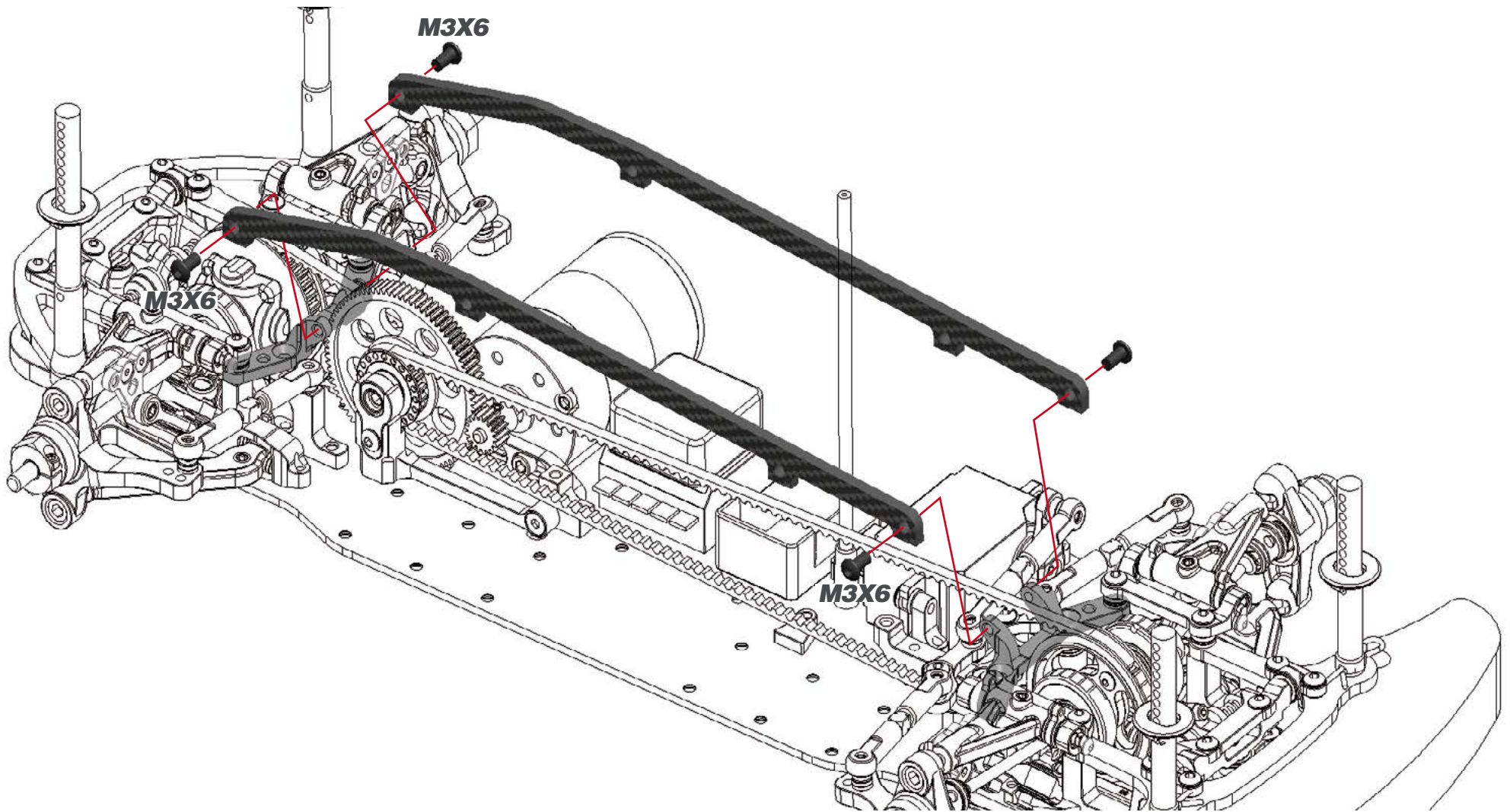

STEP 67

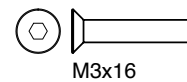
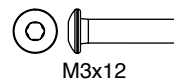
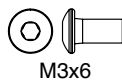
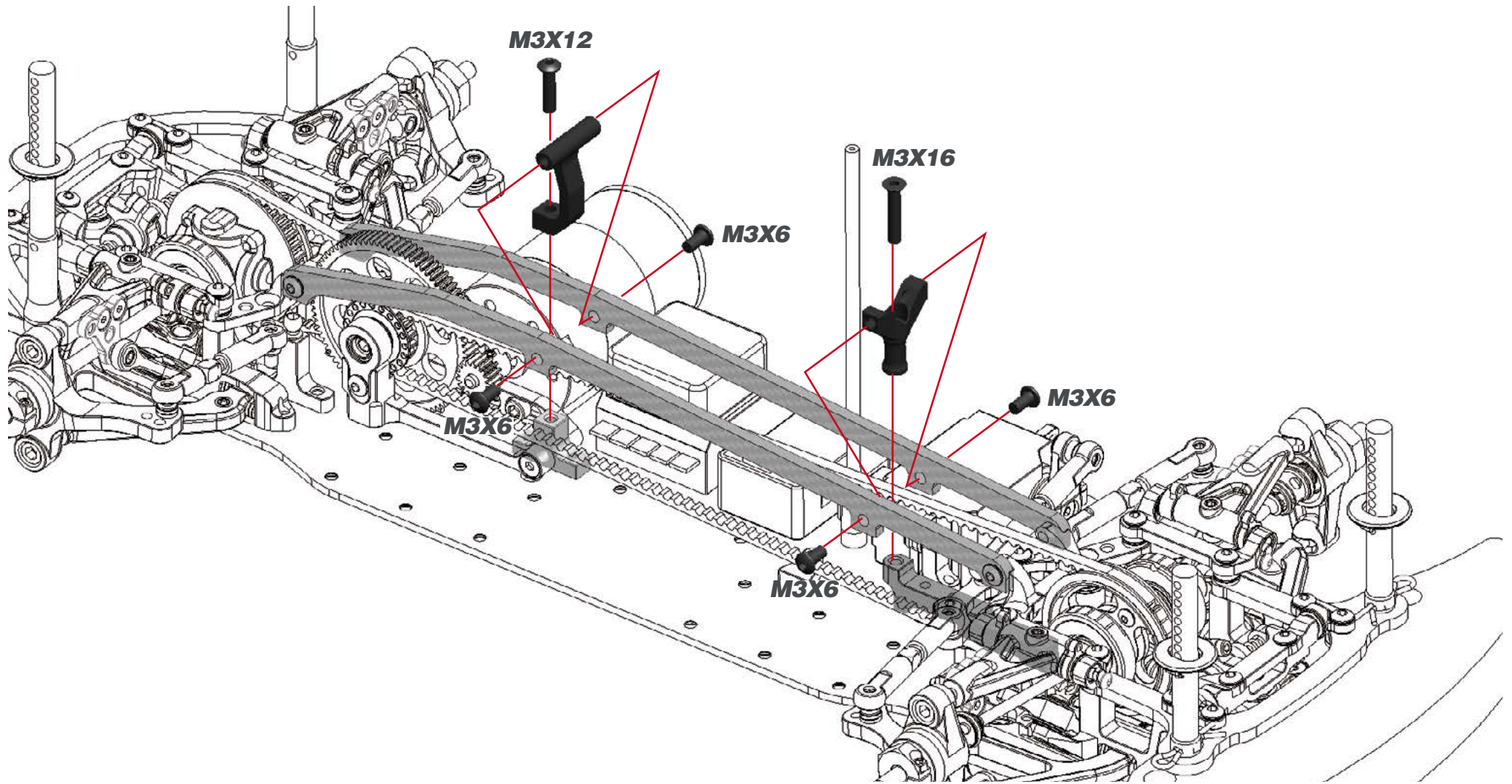

STEP 68

① M3x5



Sharp edges on battery mounts may easily cut the tape during a crash. Make small chamfers on the cutouts

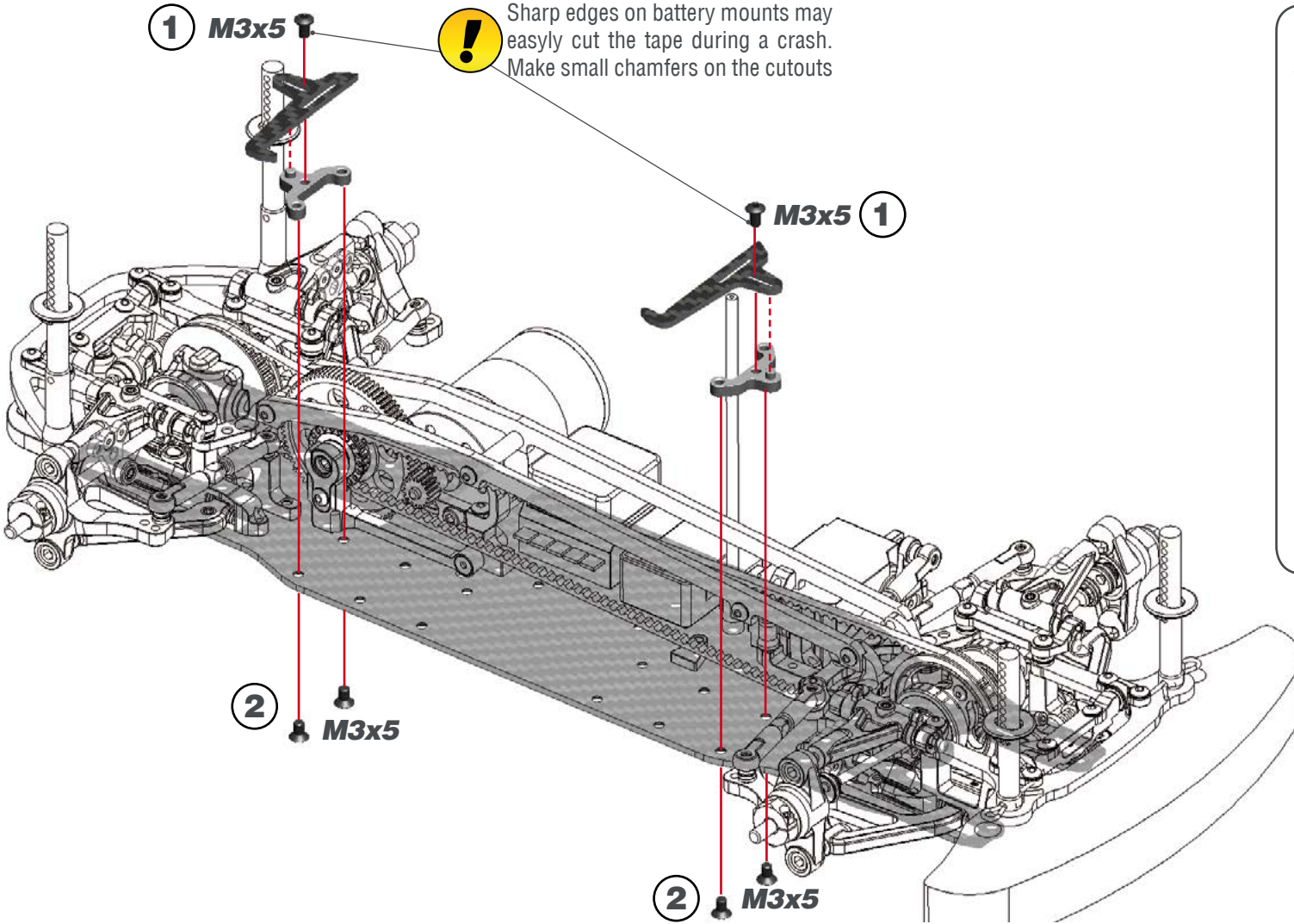

BATTERY MOUNT POSITION
The battery mount can be moved forward or rearward 3mm. Use the battery in the rearward position as default.

REAR

FRONT

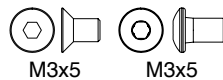
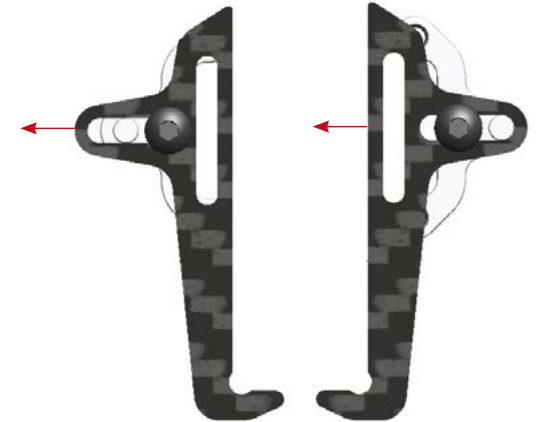

M3x5

M3x5

STEP 69

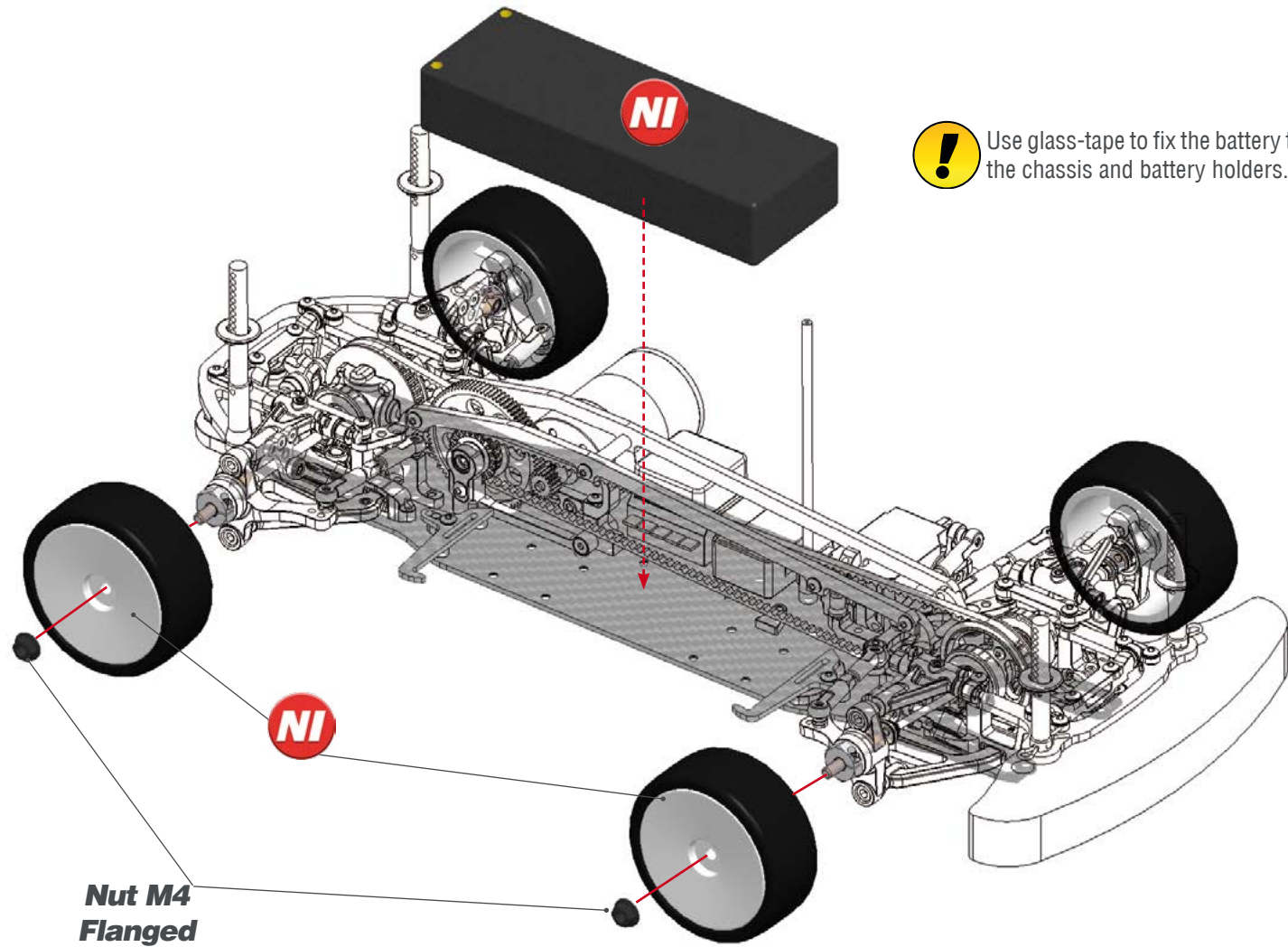

INDEX

<i>DIFF, MID AND FRONT SHAFTS EXPLODED VIEW</i>	42
<i>SHOCKS AND ROLL DAMPER EXPLODED VIEW</i>	43
<i>REAR I EXPLODED VIEW</i>	44
<i>FRONT I EXPLODED VIEW</i>	45
<i>TRANSMISSION EXPLODED VIEW</i>	46
<i>FRONT II EXPLODED VIEW</i>	47
<i>REAR II EXPLODED VIEW</i>	48
<i>FINAL EXPLODED VIEW</i>	49
<i>TEAM SERPENT NETWORK</i>	50

DIFF, MID AND FRONT SHAFTS EXPLODED VIEWS

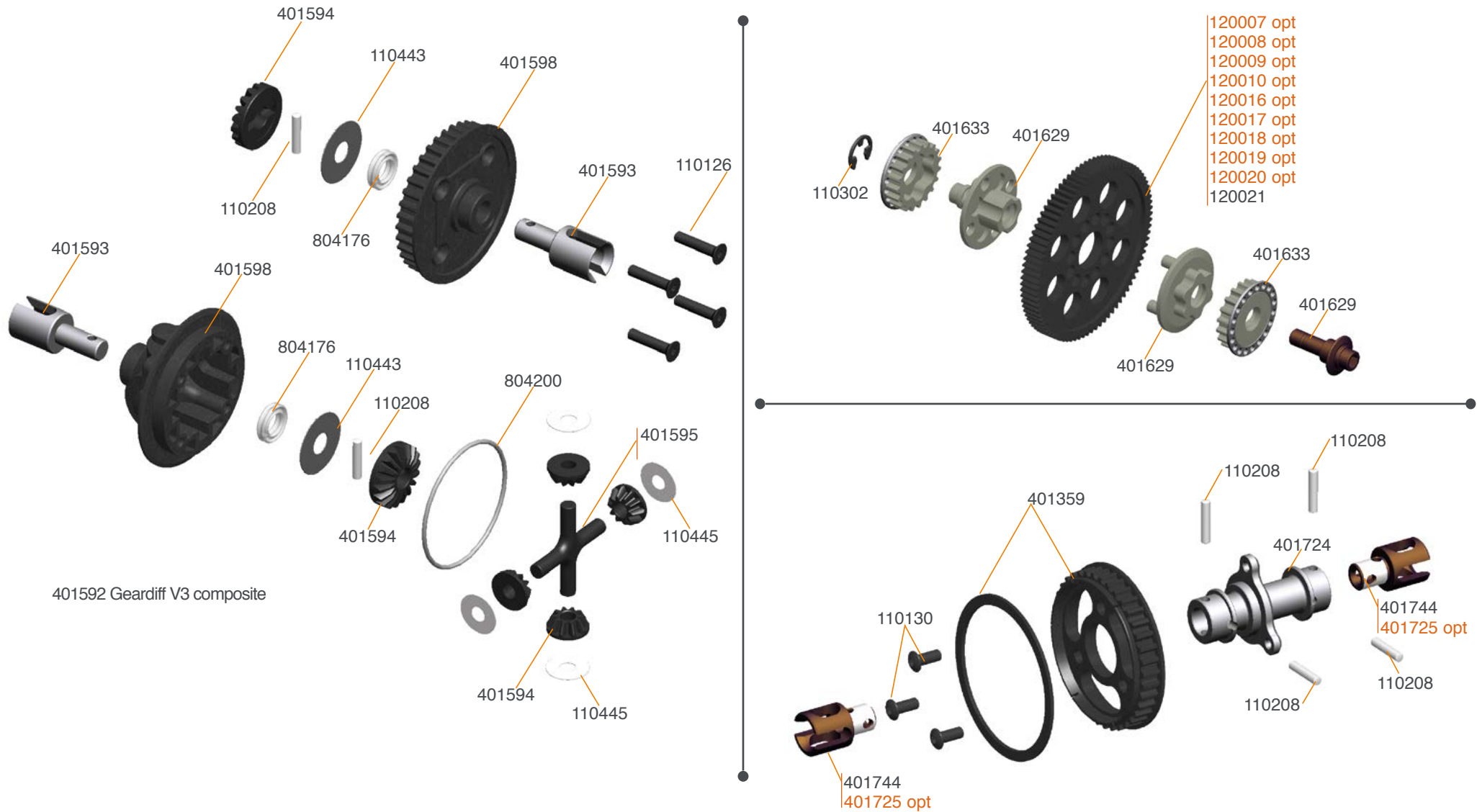

401409 Blade (16)
401592 Geardiff V3 composite
401725 Drive adaptor solid axle (2)

120007 Spur-gear Super-True 64P / 100T
120008 Spur-gear Super-True 64P / 104T
120009 Spur-gear Super-True 64P / 108T

120016 Spur-gear Super-True 48P / 72T
120017 Spur-gear Super-True 48P / 75T
120018 Spur-gear Super-True 48P / 78T

120019 Spur-gear Super-True 48P / 81T
120020 Spur-gear Super-True 48P / 84T
120021 Spur-gear Super-True 48P / 87T

SHOCK AND ROLL DAMPER EXPLODED VIEW

401760 Shock set 4X EVO

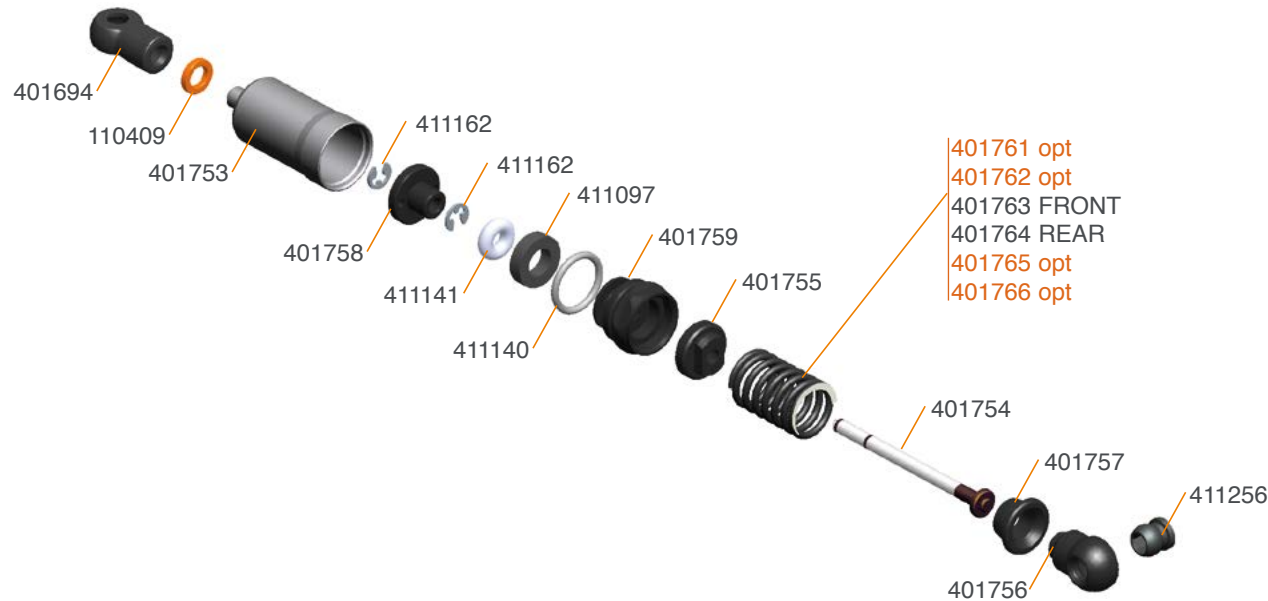

- 401761 opt
- 401762 opt
- 401763 FRONT
- 401764 REAR
- 401765 opt
- 401766 opt

401702 Roll damper 4-X

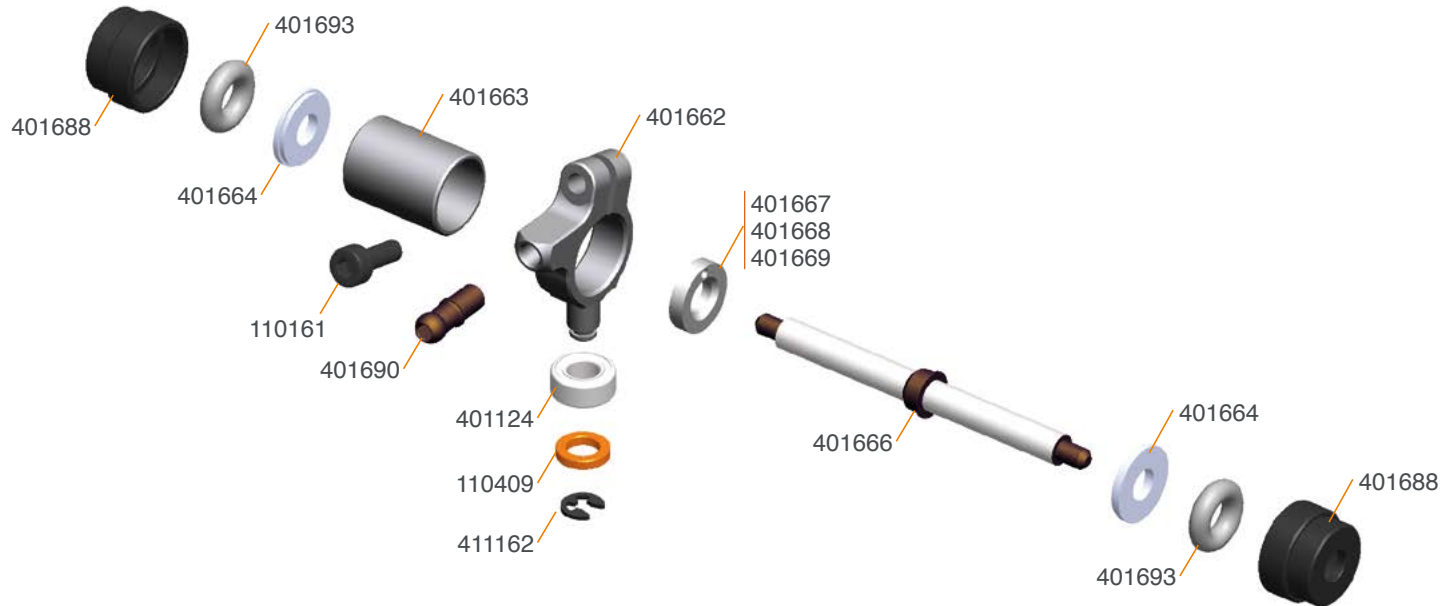

- 401761 Shock spring white C=4.6 4X EVO (2)
- 401763 Shock spring orange C=5.6 4X EVO (2)
- 401764 Shock spring pink C=6.3 4X EVO (2)

- 401766 Shock spring blue C=7.8 4X EVO (2)

REAR / EXPLODED VIEW

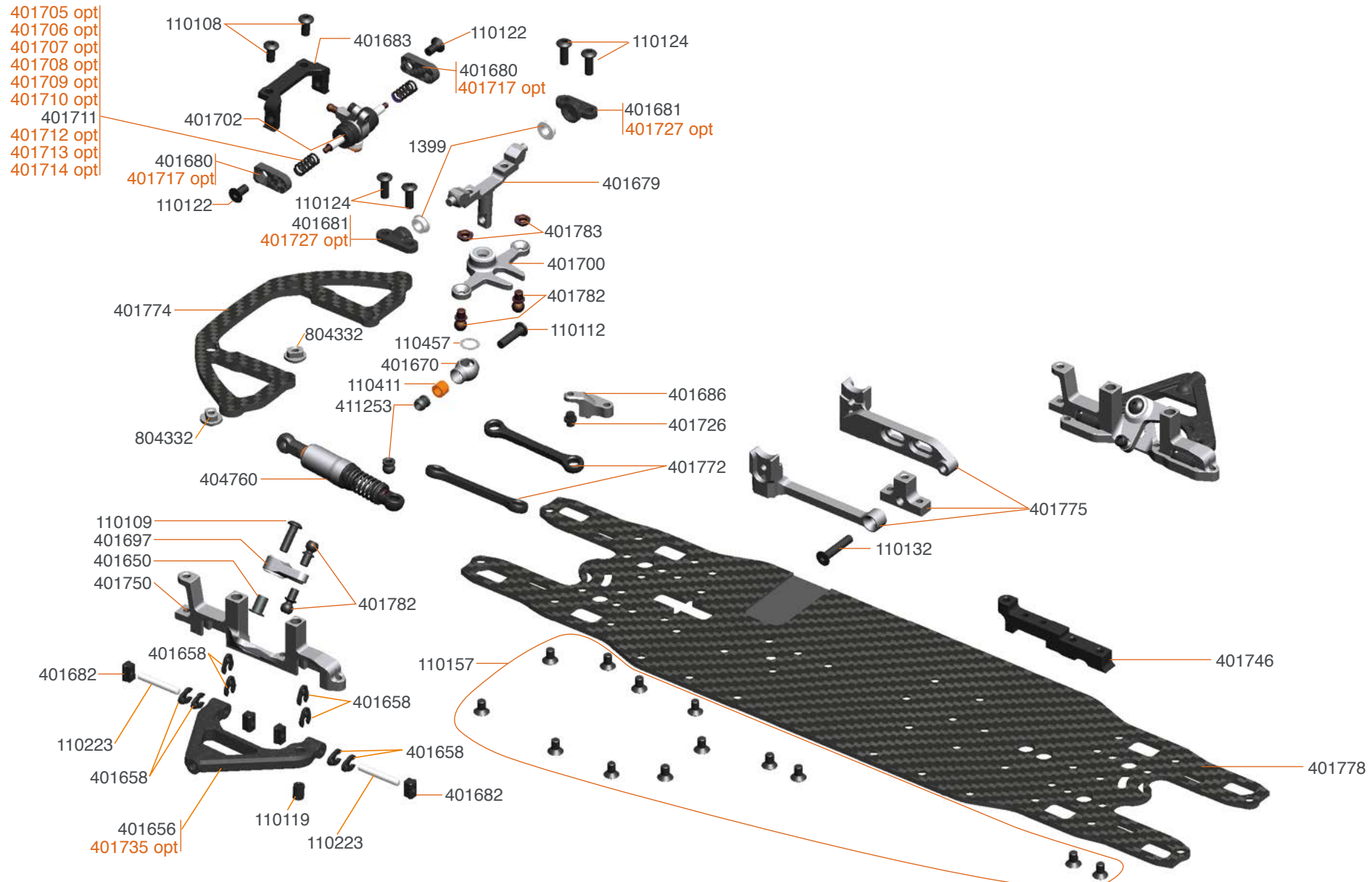

- 401701 Roll damper set 4-X
- 401705 Spring white C4.4 4-X (2)
- 401706 Spring yellow C4.9 4-X (2)
- 401707 Spring orange C5.5 4-X (2)
- 401708 Spring red C6.3 4-X (2)

- 401709 Spring pink C6.9 4-X (2)
- 401710 Spring blue C7.6 4-X (2)
- 401712 Spring green C9.5 4-X (2)
- 401713 Spring grey C10.9 4-X (2)
- 401714 Spring black C12 4-X (2)

- 401717 Roll damper support -7mm carbon 4-X (2)
- 401727 Bearing holder central rocker alu 4-X (2)
- 401735 Wishbone lower fr/r hard 4X (2)



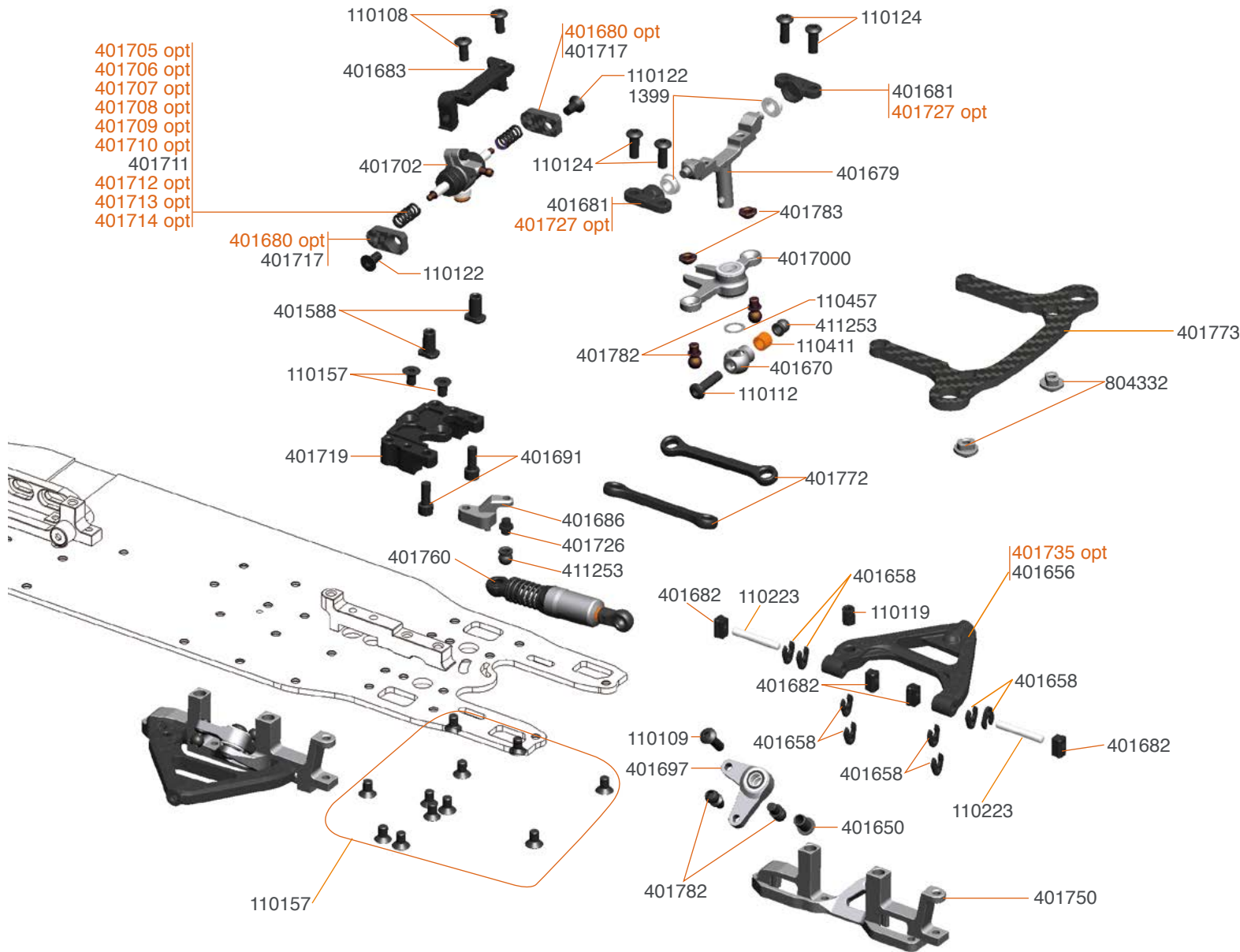

- 401680 Roll damper support carbon 4-X (2)
- 401701 Roll damper set 4-X
- 401705 Spring white C4.4 4-X (2)
- 401706 Spring yellow C4.9 4-X (2)
- 401707 Spring orange C5.5 4-X (2)
- 401708 Spring red C6.3 4-X (2)
- 401709 Spring pink C6.9 4-X (2)
- 401710 Spring blue C7.6 4-X (2)
- 401712 Spring green C9.5 4-X (2)
- 401713 Spring grey C10.9 4-X (2)
- 401714 Spring black C12 4-X (2)
- 401716 Bumper top plate narrow front carbon 4-X
- 401727 Bearing holder central rocker alu 4-X (2)
- 401735 Wishbone lower fr/r hard 4X (2)z

TRANSMISSION EXPLODED VIEW

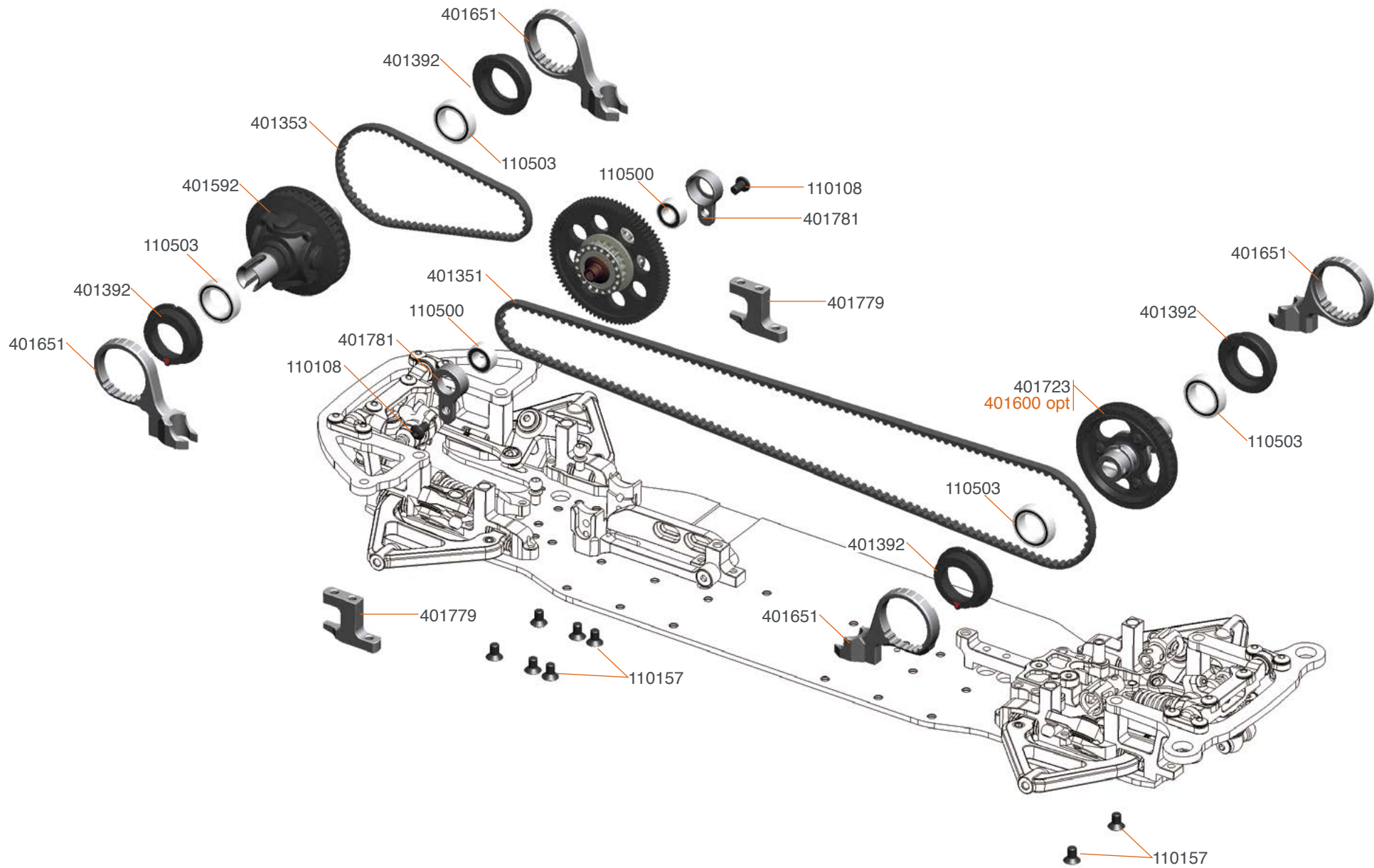

401600 Solid axle alu S411 mono for blades
401780 RRS holder low alu



FRONT II EXPLODED VIEW

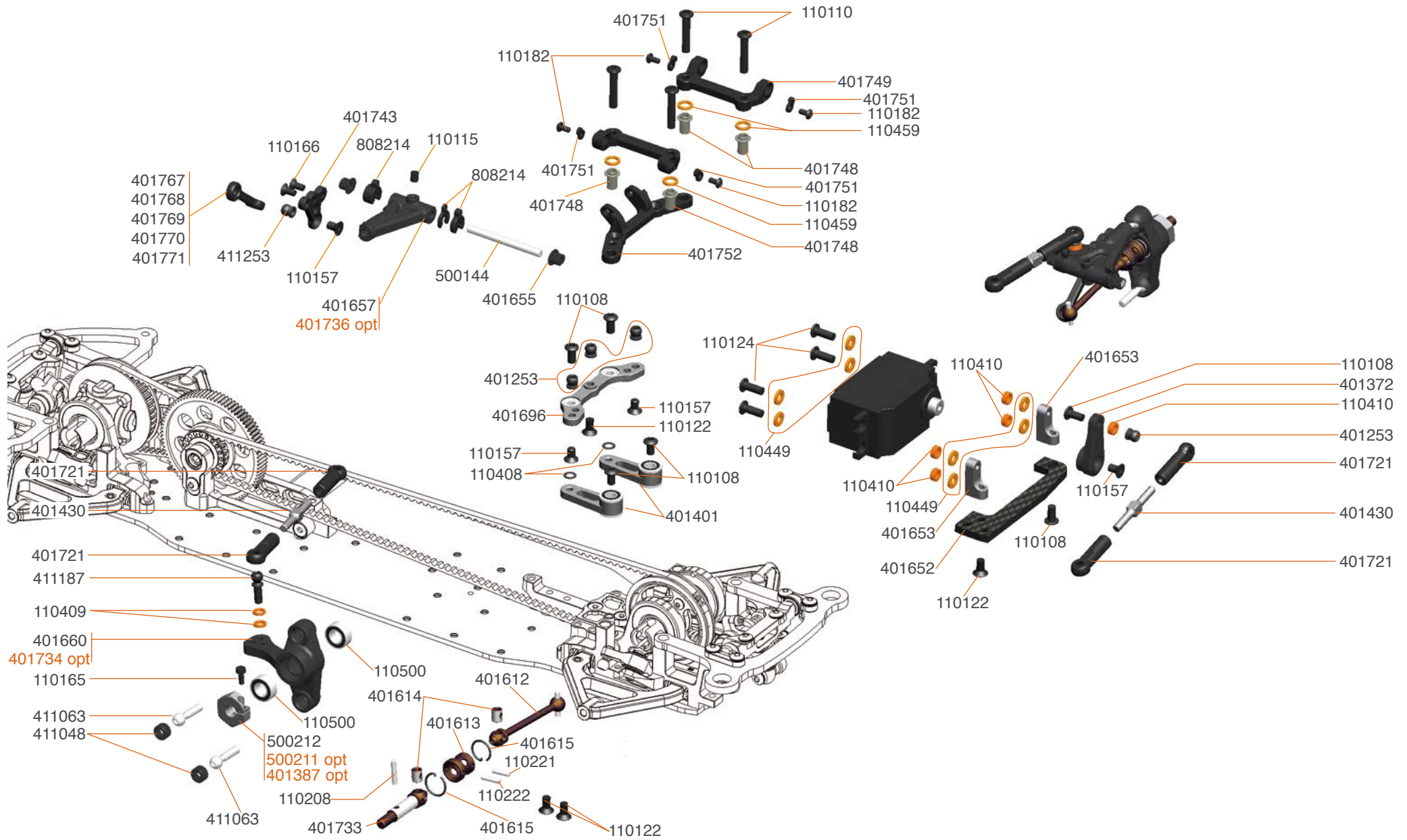

- OPT** 401387 Wheelhexagon 1mm offset (2)
- 500211 Wheelhexagon +0.75mm offset (2)
- 401734 Wheelhub fr/r r l+r hard 4X
- 401736 Wishbone upper fr/r r hard 4X (2)

REAR II EXPLODED VIEW

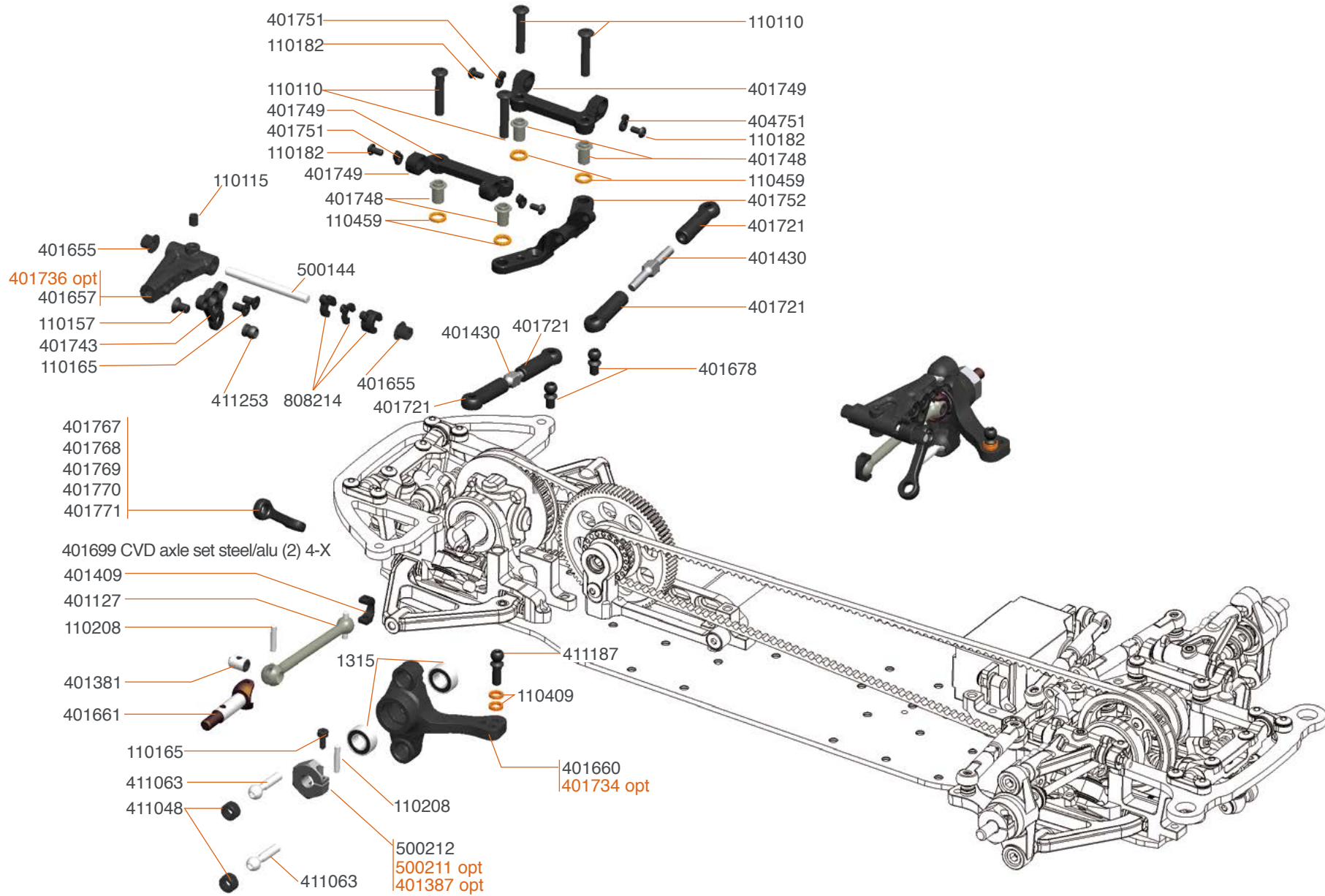

- 401387 Wheelhexagon 1mm offset (2)
- 401734 Wheelhub fr/rr l+r hard 4X
- 401736 Wishbone upper fr/rr hard 4X (2)
- 500211 Wheelhexagon +0.75mm offset (2)



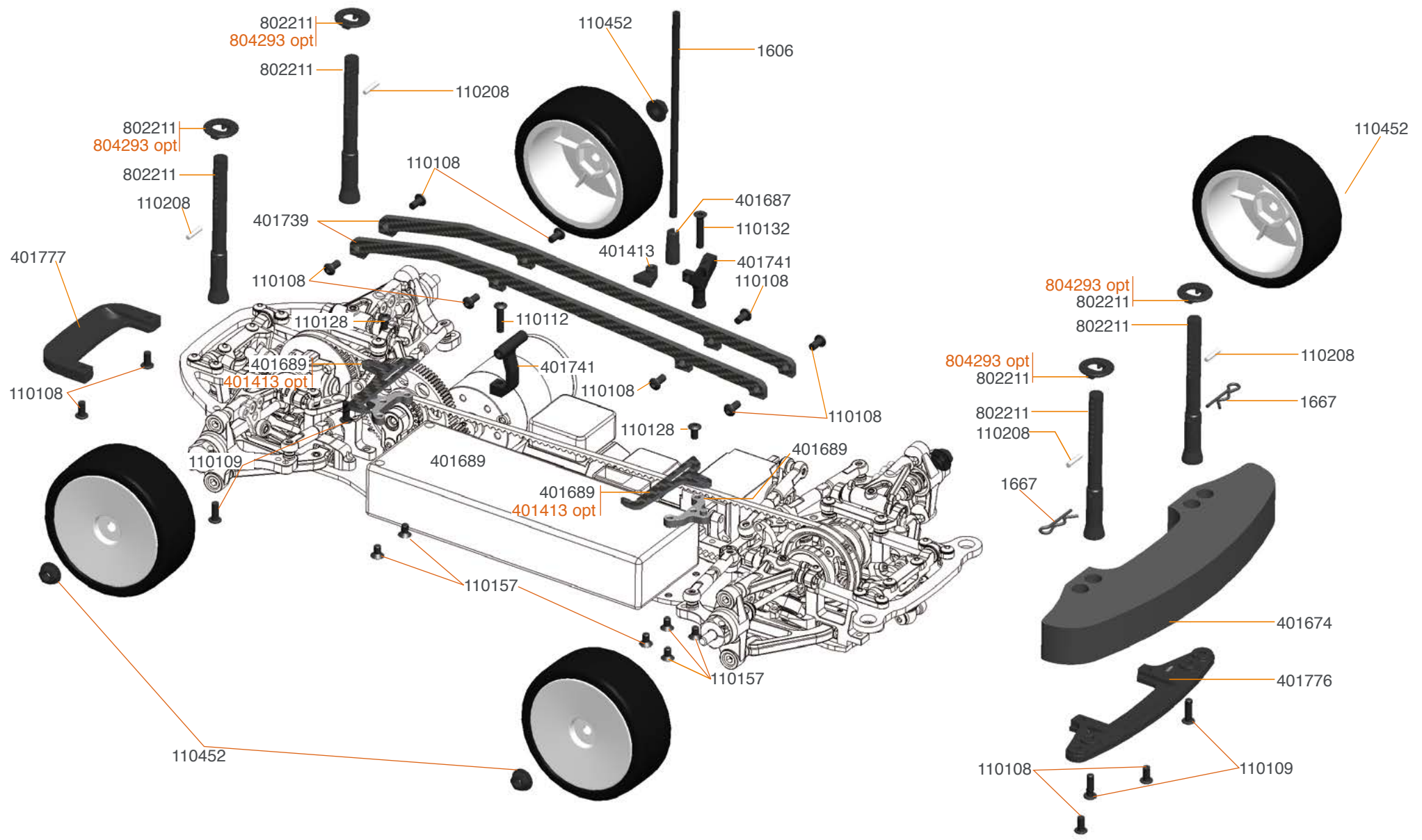

OPT 401413 Battery mount (4)
804293 Body support washers med + high (5+5)

TEAM SERPENT NETWORK

PROJECT 4X SPARE PARTS www.serpent.com/400031/spares/

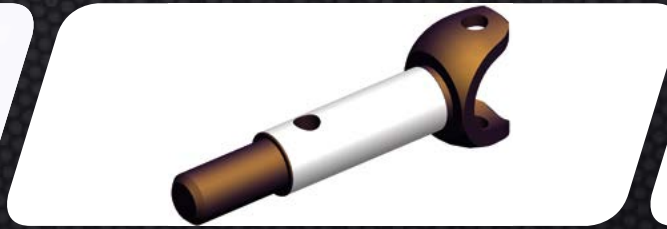

PROJECT 4X OPTIONALS PARTS www.serpent.com/400031/Optionals/

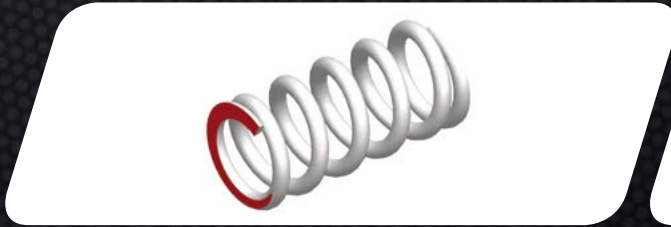

SERPENT TOOLS www.serpent.com/product/Tools/



SERPENT MERCHANDISING www.serpent.com/product/Merchandising/



SERPENT WEBSITE AND BLOG

www.serpent.com
www.teamserpent.com
www.dragon-rc.com

SERPENT PROMO PAGES <http://promo.serpent.com>

SERPENT FACEBOOK GROUPS <http://promo.serpent.com/indexfb.htm>

SERPENT ADVANCED MANUALS <http://promo.serpent.com/sam/>

SERPENT SOCIAL MEDIA



www.facebook.com/SerpentMRC



www.youtube.com/user/SerpentMRC



www.twitter.com/SerpentMRC



www.plus.google.com/+SerpentModelcars/posts



www.weibo.com/teamserpent

Project 4X EVO

1/10 scale electric touring car



98208 Manual Project 4X EVO