

INSTRUCTION MANUAL

F110 **SF4**

1/10 scale electric powered

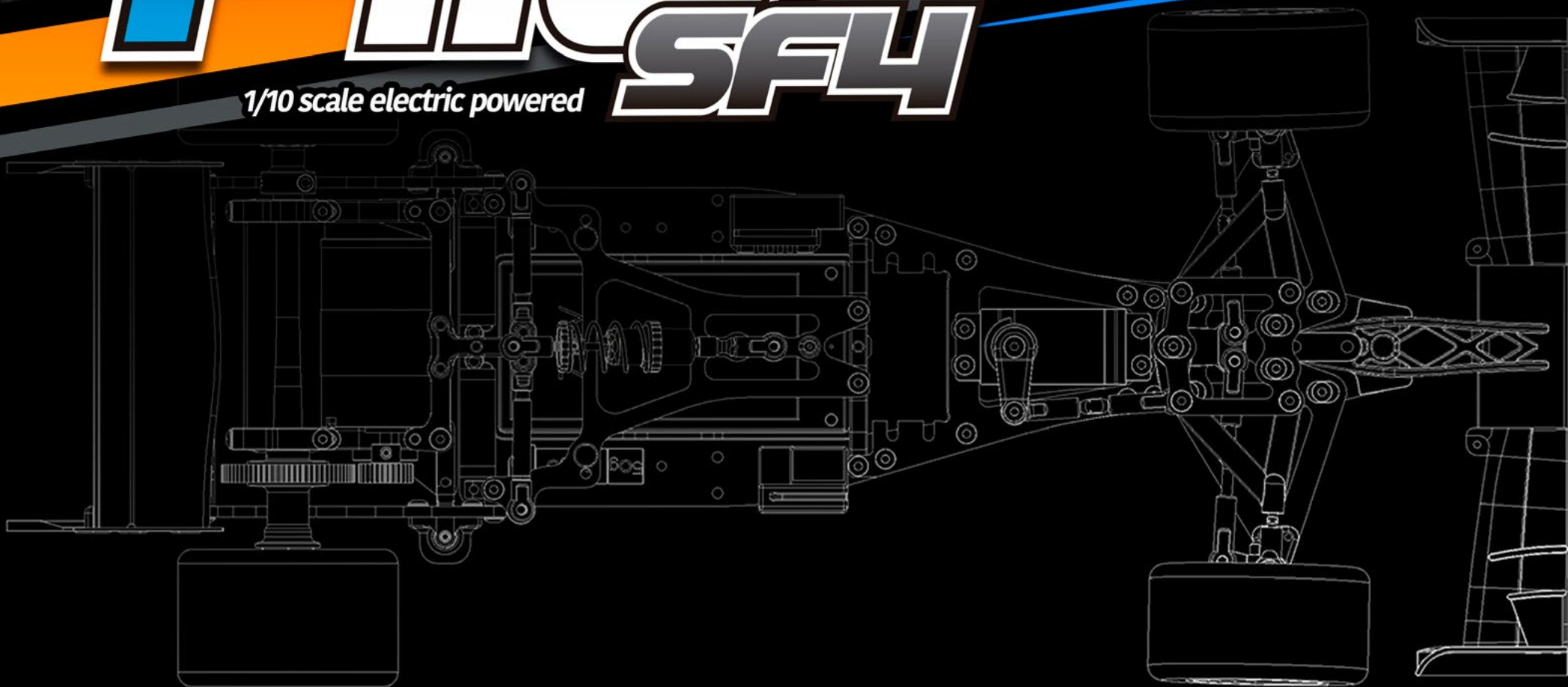

SERPENT

INTRODUCTION

Serpent developed the Serpent F110 SF4 model car for demanding racers in the more and more competitive electric 1/10th scale F1 class. Like all our previous cars, it has been designed to win straight from the box.

A number of innovative features, developed to create maximum performance are combined to make a unique car. The side-link free design in combination with the chassis-mounted rear wing gives you unprecedented rear grip while front and rear topdeck ensure maximum steering precision.

The Serpent F110 SF4 should see you in the winners circle in no time. In fact everything associated with this car is of the highest quality, from the packaging and supplied online manuals, right through to the product and race support. For latest information about Serpent F110 SF4 check on: www.serpent.com/410067

Enjoy racing !

Team Serpent
Multiple World Champions

INSTRUCTIONS

Serpent's long tradition of excellence extends to the instruction manuals, and this instruction manual is no exception. The easy-to-follow layout is richly illustrated with 3D-rendered full-color images to make your building experience quick and easy. Following the instructions will result in a well-built, high-performance race-car that will soon be able to unleash its full potential at the racetrack. The kit includes bags, with bag numbers, which refer to the same step in the manual. Open only the indicated bag(s) per step and finish that part of the assembly. Remaining parts will be needed later on in the assembly process.

PLASTIC PARTS

The Serpent moulded parts are very durable and hard. When assembling longer screws in new composite parts, make sure to use new hex bits in your (power) tools. Pre-threading also helps to avoid screw damage.

SETUP

In certain assembly steps you need to make basic adjustments, which will give you a good initial setup for your Serpent F110 SF4. Fine-tuning the initial setup is an essential part of building a high-performance racecar like your Serpent F110 SF4.

EXPLODED VIEWS AND PARTS LIST

The exploded views and parts lists for the Serpent F110 SF4 are presented in the Reference Guide section in the back of this manual. The exploded views show all the parts of a particular assembly step along with the Serpent part number and hotlink to the Serpent website. Part numbers in orange indicates that this part is an optional. Optional part names and numbers are showed below.

CUSTOMER SERVICE

Serpent has made a strong effort to make this manual as complete and clear as possible. Additional info may be published in our website: www.serpent.com or you may ask your dealer or the Serpent distributor for advice, or email Serpent direct: info@serpent.com. The Serpent Facebook, Twitter and Youtube pages give additional means of support and communications.

SAFETY

Read and take note of the 'Read this First section' before proceeding to assemble the car-kit. This car-kit is intended for persons aged 16 or older.

READ THIS FIRST!

- This is a highly technical hobby product, intended to be used in a safe racing environment. This car is capable of speeds in excess of 80 km/h or 50mph. Please follow these guidelines when building and operating this model.
- Parental guidance is required when the builder/user of this car is under 16.
- Follow the building instructions. If in doubt, contact your dealer or importer.
- Be sure to use the proper tools when assembling the car. Always exercise caution when using electric tools, knives and other sharp objects.
- Be careful when using liquids like lubrication oil, fuel or glue. Do not swallow.
- Follow the manufacturer's instruction in case you experience irritation after using the product.
- Be careful when operating the car. Stay away from any rotating parts such as wheels, gears and transmission. Stay away from motor, engine and exhaust pipe system or speedo during and immediately after use, as these parts may be very hot. We advise to use protective hand gloves.
- Only operate this car in a safe environment, like a special racing track or a closed parking lot. Avoid using this car on public roads, crowded places or near infants.
- Before operating this car, always check the mechanical status of the car. Also check that the transmitter and receiver frequencies correspond and are not used by any other racer at the same time. Check that the batteries of the transmitter and receiver- are fully charged.
- After use, always check all the mechanics of the car. We advise to clean the car immediately after use, and inspect the parts for wear or fractures. Replace when necessary. Do not use water, methanol, thinner or other solvents to clean the car.
- Empty the fuel tank (depending on model) if needed and disconnect the receiver battery.
- Store the car in a dry and heated place to avoid corrosion of metal parts.
- Avoid using this car in wet conditions as the water will cause corrosion on the metal parts and bearings and these parts will cease to function properly. If driven in the wet, ensure that all the electric equipment is waterproofed and after use, that all moving parts are dried immediately.

CONTENTS

• FRONT ASSEMBLY	4
• CENTRAL ASSEMBLY	10
• REAR ASSEMBLY	12
• CENTRAL II ASSEMBLY	18
• SHOCK ASSEMBLY	23
• ELECTRONICS ASSEMBLY	25
• FINAL ASSEMBLY	28
• EXPLODED VIEWS	32
• TEAM SERPENT NETWORK	40

LINES DESCRIPTION

Each step contains a variety of numbers, lines, and symbols. The numbers represent the order in which the parts should be assembled. The lines are described below.



Step number; the order in which you should assemble the indicated parts



Length after assembly



Assembly path of one item into another



Group of items (within lines) should be assembled first



Direction the item should be moved



Glue one item to another



Connect one item to another



Gap between two items



Press/Insert one item into another

ICONS DESCRIPTION

Each step contains a variety of symbols described below.



Carefull, read and check very well.



Apply a small amount of cyano glue. Use wear protection for eyes and hands.



Detail view to explain assembly or order of parts better.



Default set-up: This symbol indicates the default setup.



Grease: apply a small amount of grease to the parts shown.



Silicone grease: apply a small amount of grease to the parts shown.



Thread lock: apply a small amount on the parts shown. Before to apply the threadlock, make sure to degrease the parts very well, as otherwise the threadlock will not work.



Silicone oil: use the indicated silicone oil for the shocks and differentials.



Oil: apply a small amount of oil to the parts shown.



Left and right parts should be assembled in the same way.



Parts or items not included in the kit.



Optional part, not standard in the kit.

STEP 1

BAG 1

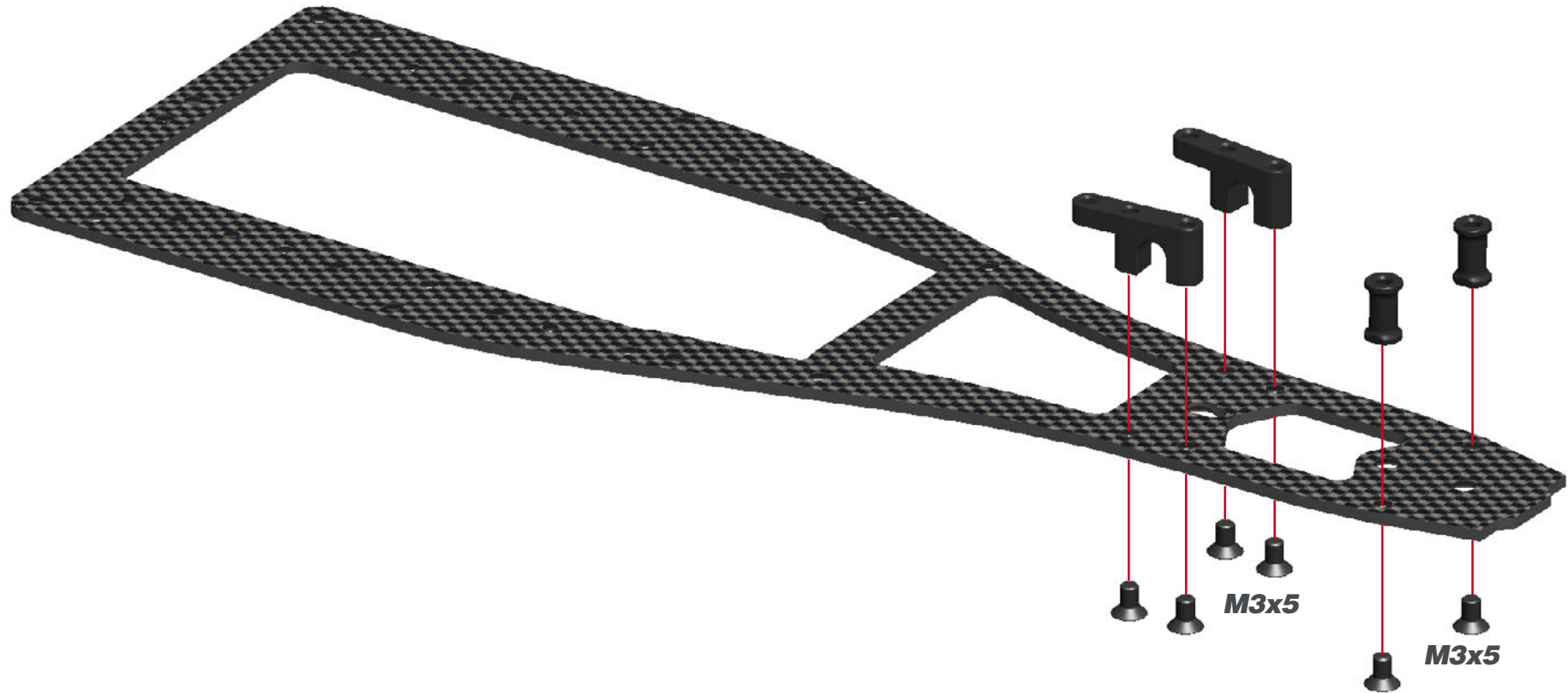

STEP 2

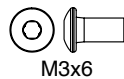
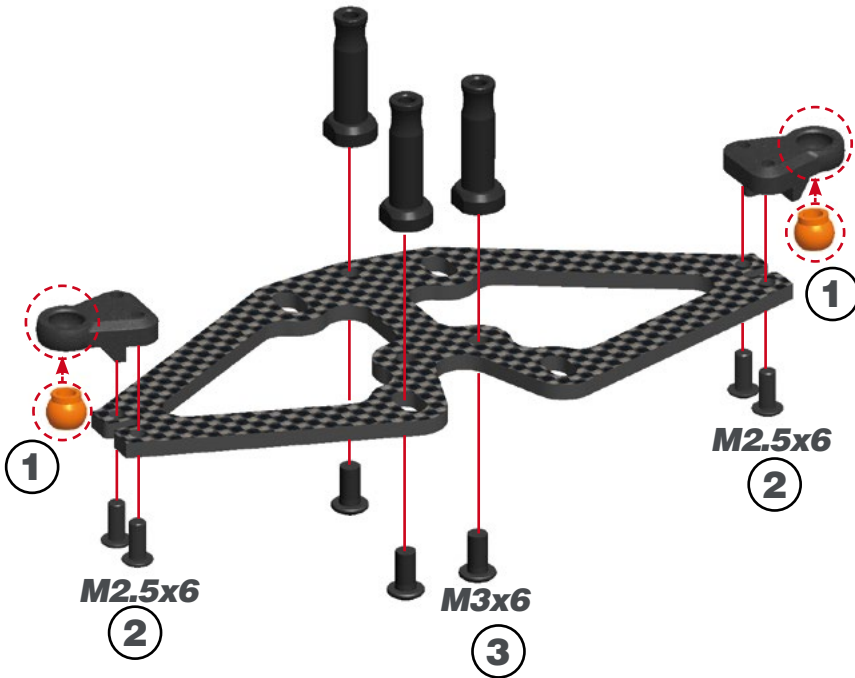

STEP 3



As default adjustment of the front ride height should be assembled 2x 3x6x1 ride height spacers. The kit includes 4x 3x6x0.5mm ride height spacers for fine tuning.

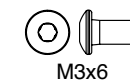
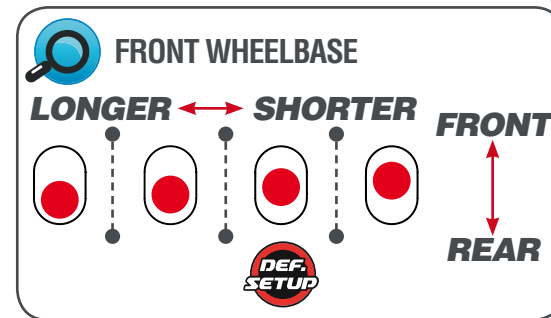
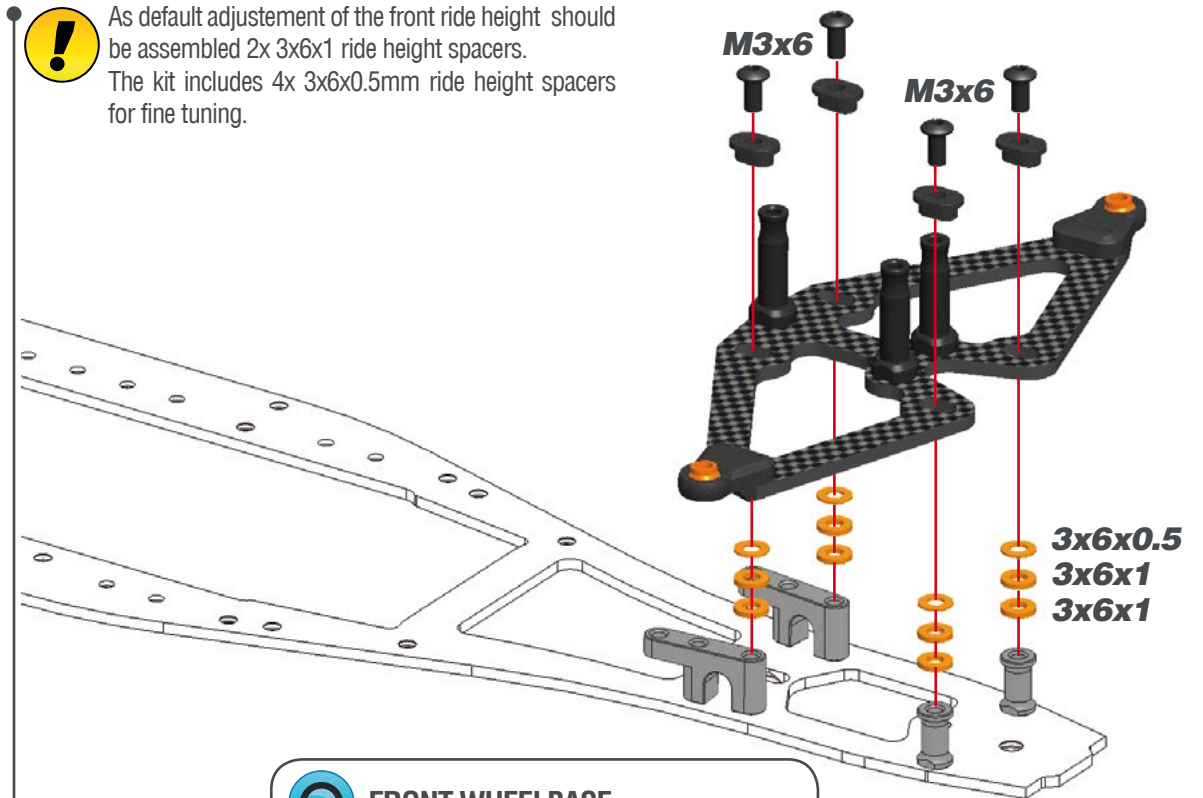

STEP 4

4.1

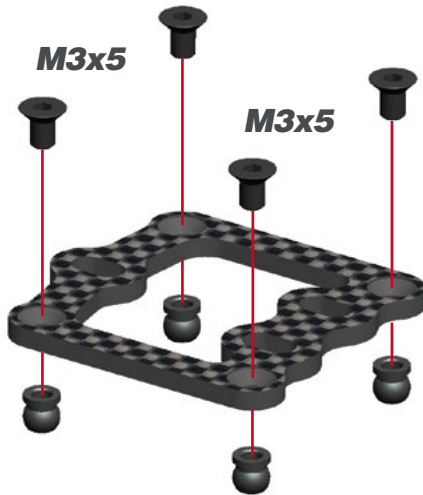

4.2

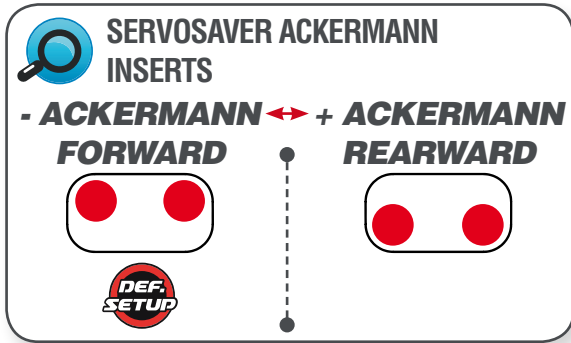

STEP 5

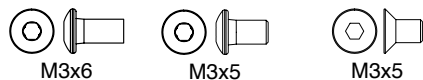
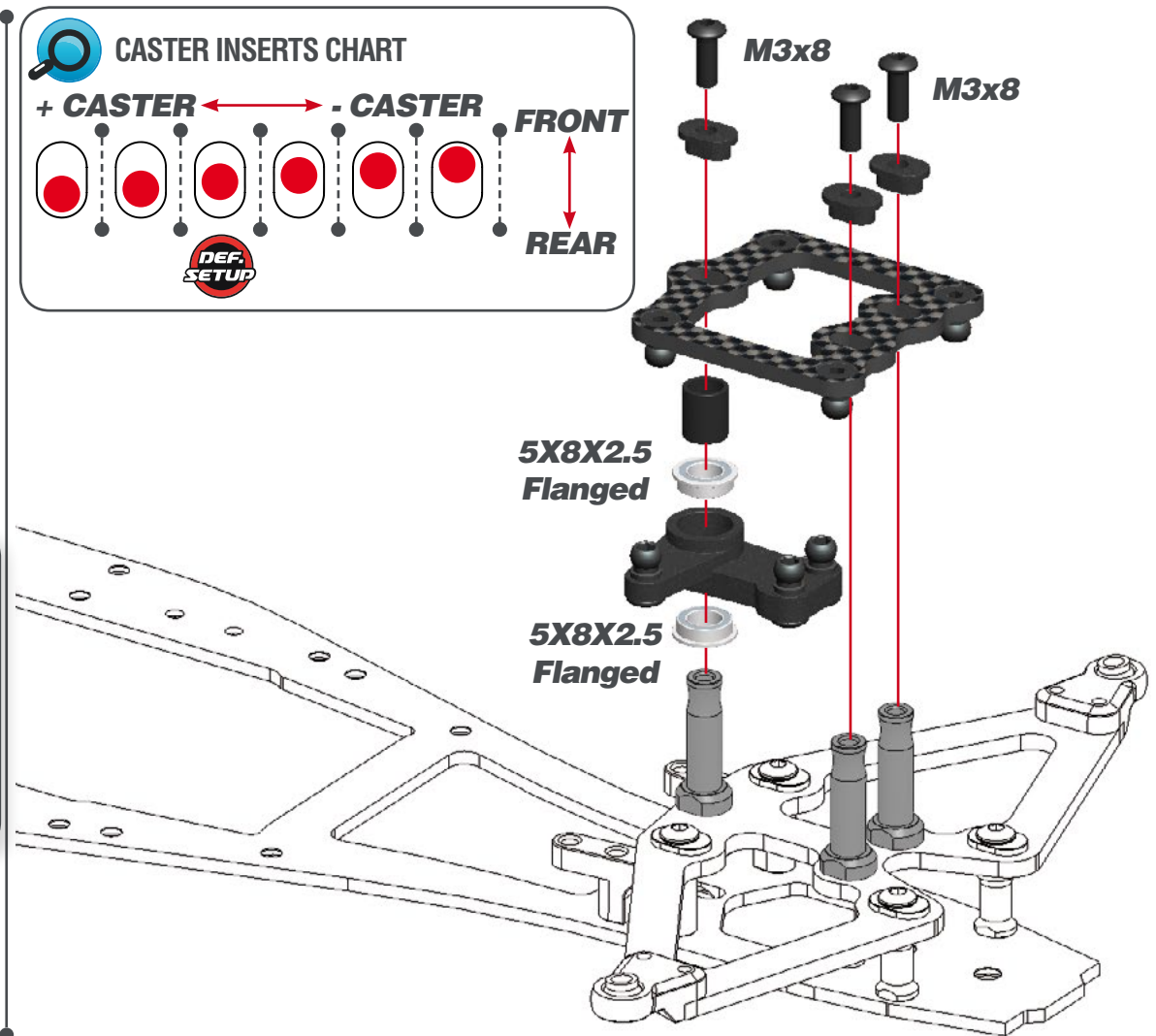
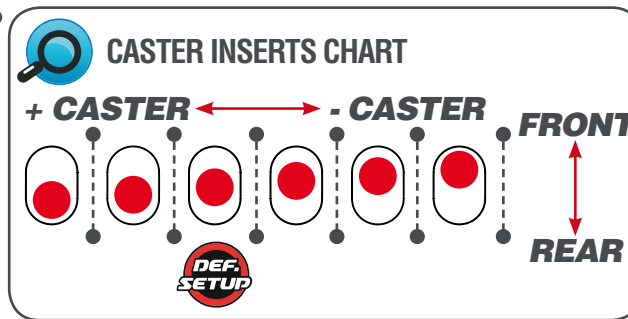



STEP 6

BAG 2

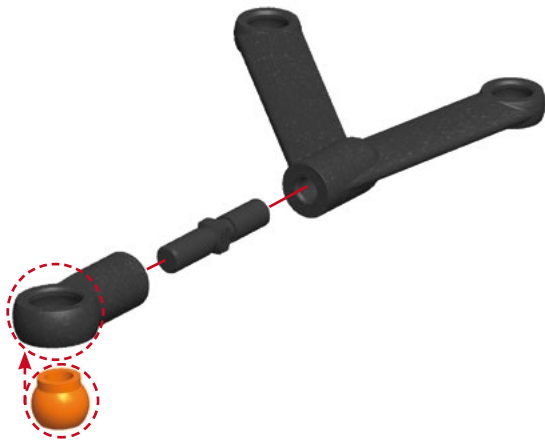
STEP 7



 **L=R**  **FRONT CAMBER**

4 mm



A diagram showing the camber link with a red double-headed arrow indicating a 4 mm adjustment range. The text 'L=R' and 'DEF. SETUP' are also present.

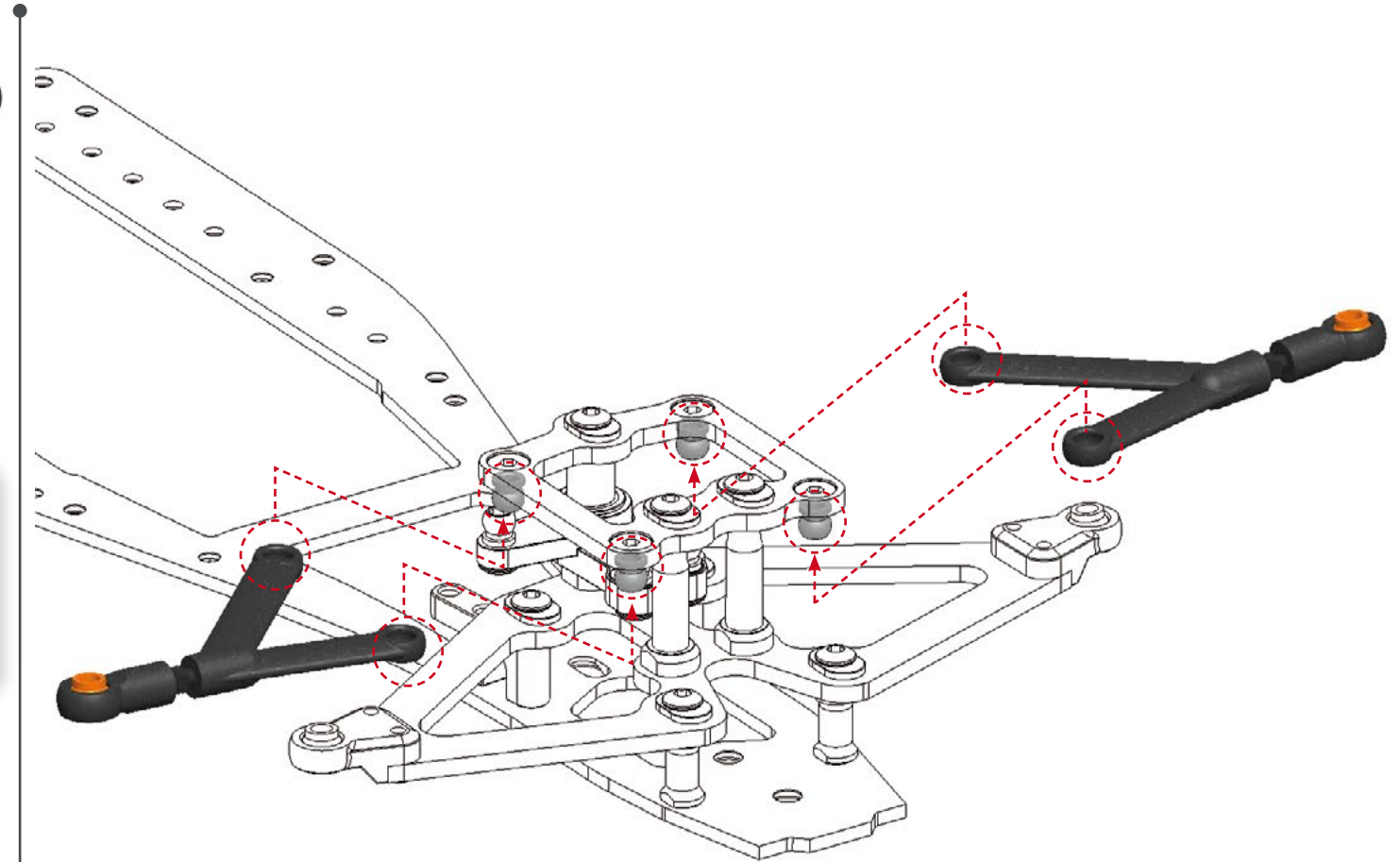

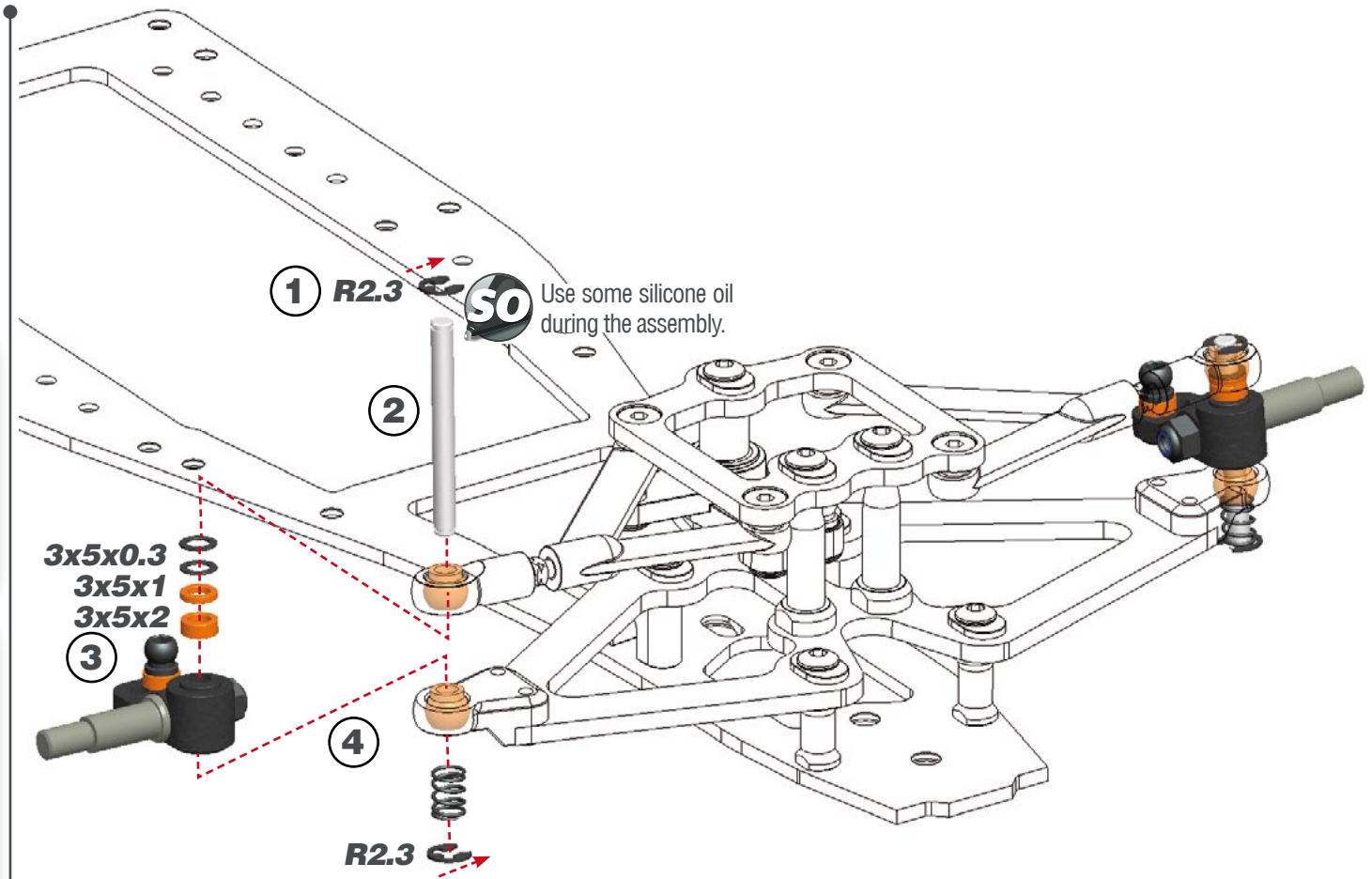
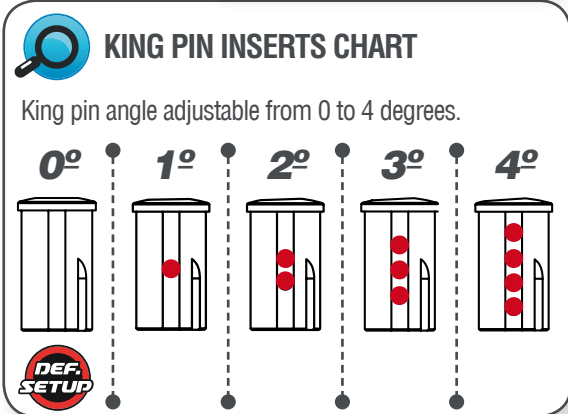
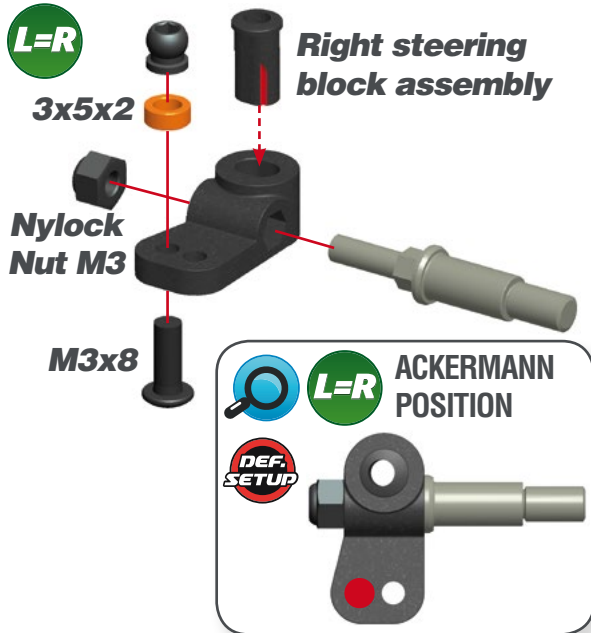

STEP 8

STEP 9





STEP 10

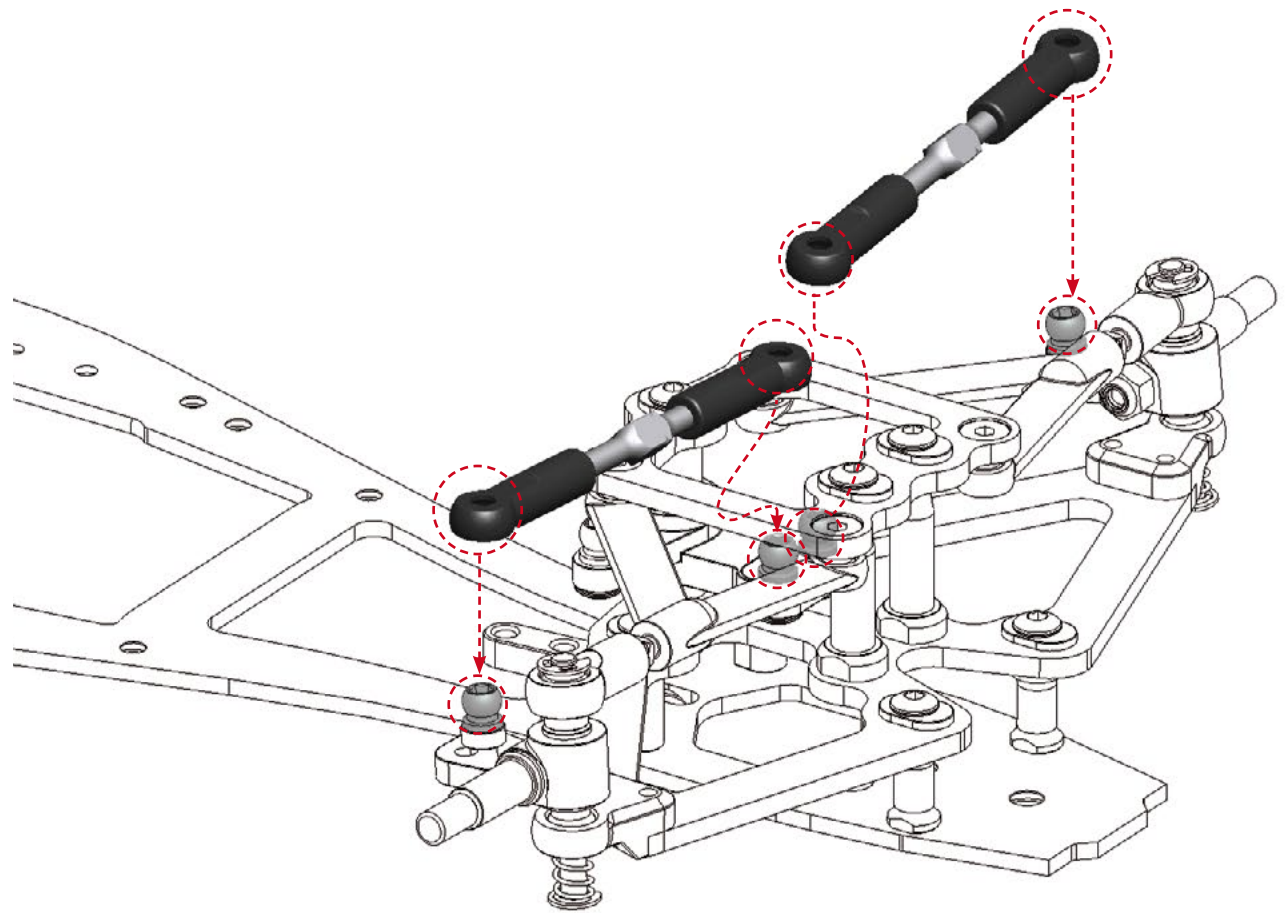

   **STEERING TRACKROD LENGTH**

19.5 mm



STEP 11

BAG 3

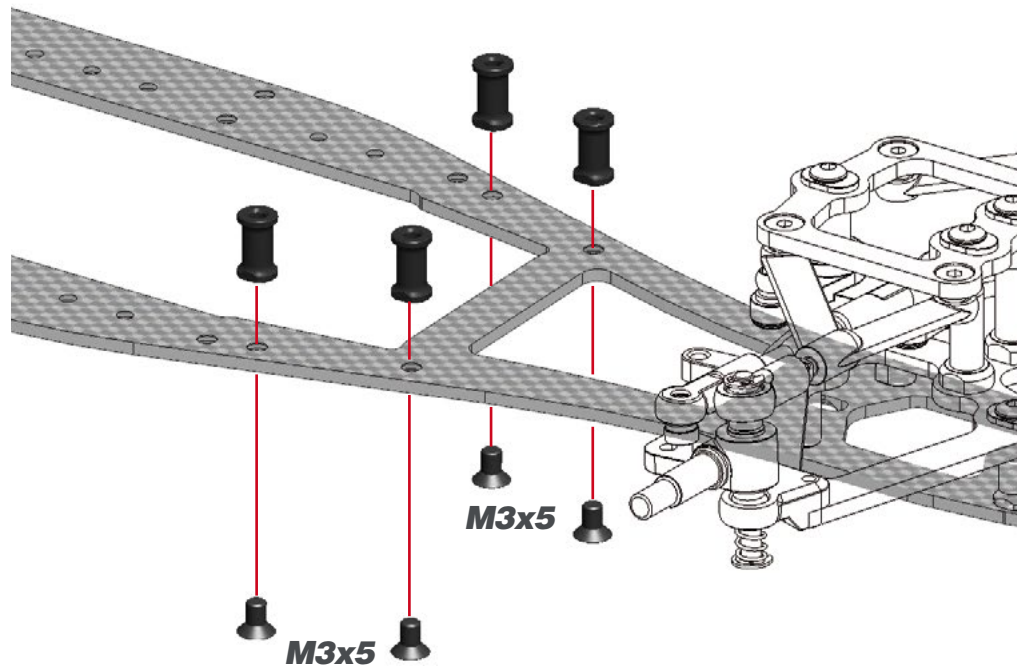

STEP 12

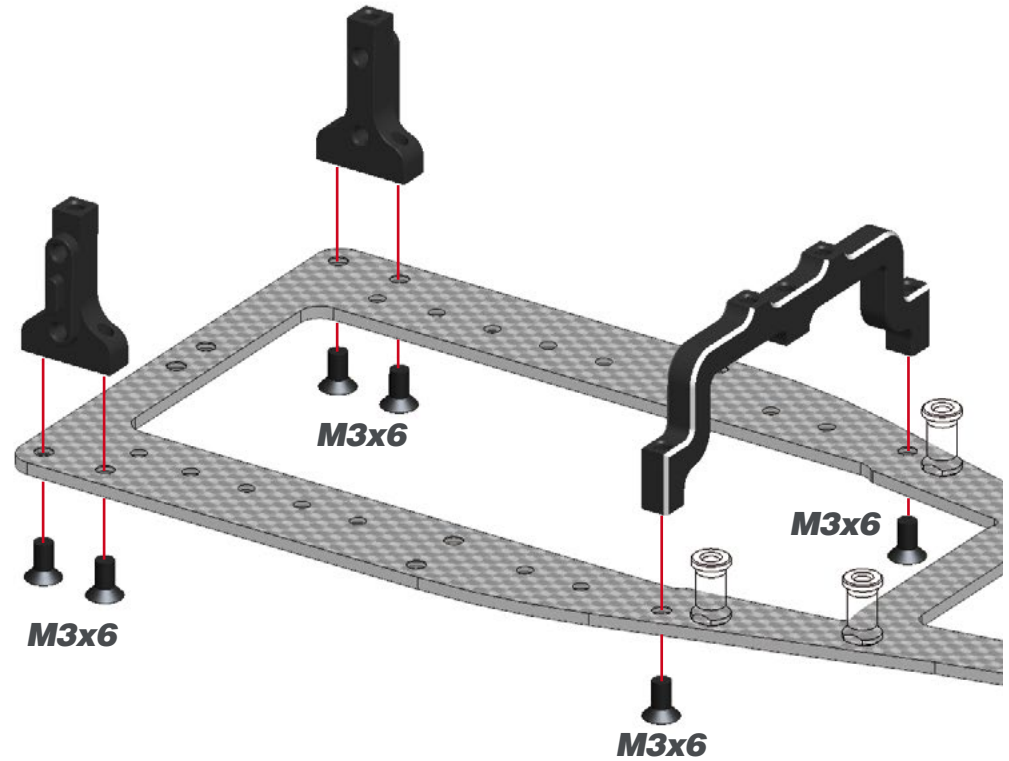

STEP 13

13.1

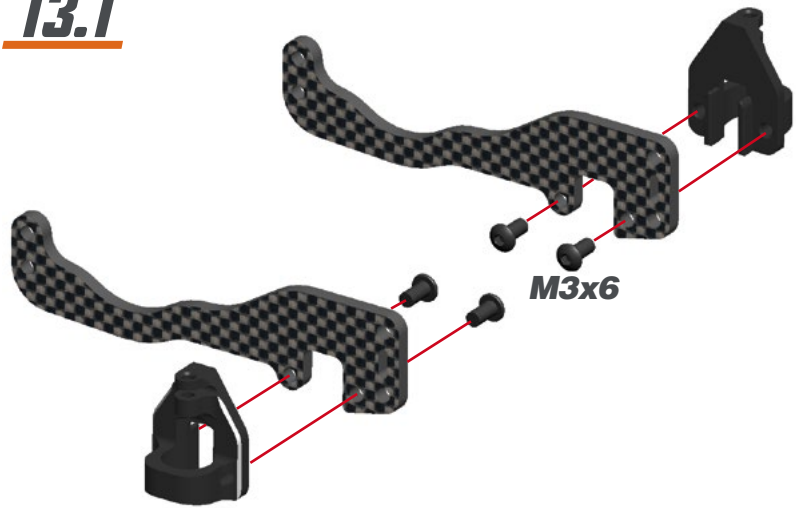

13.2

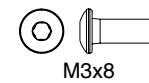
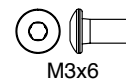
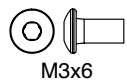
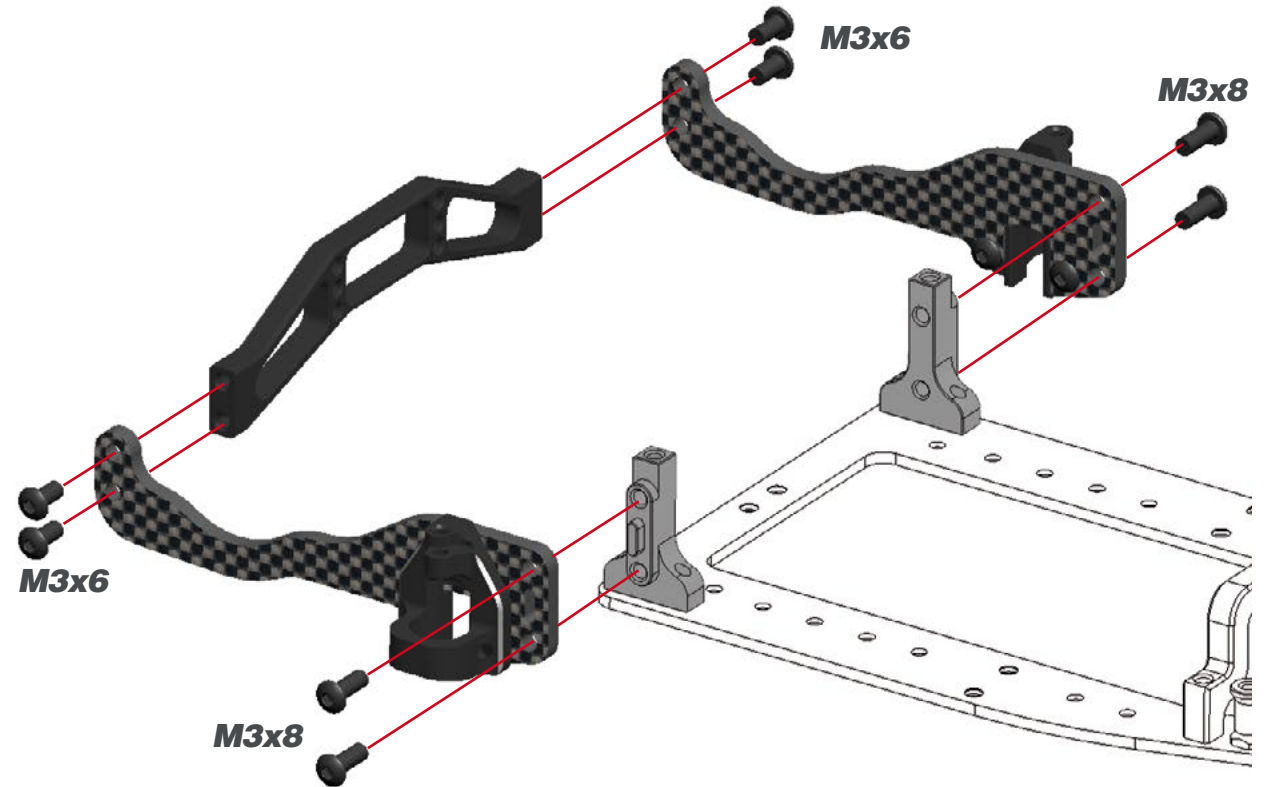

STEP 14

STEP 15 **BAG 4**

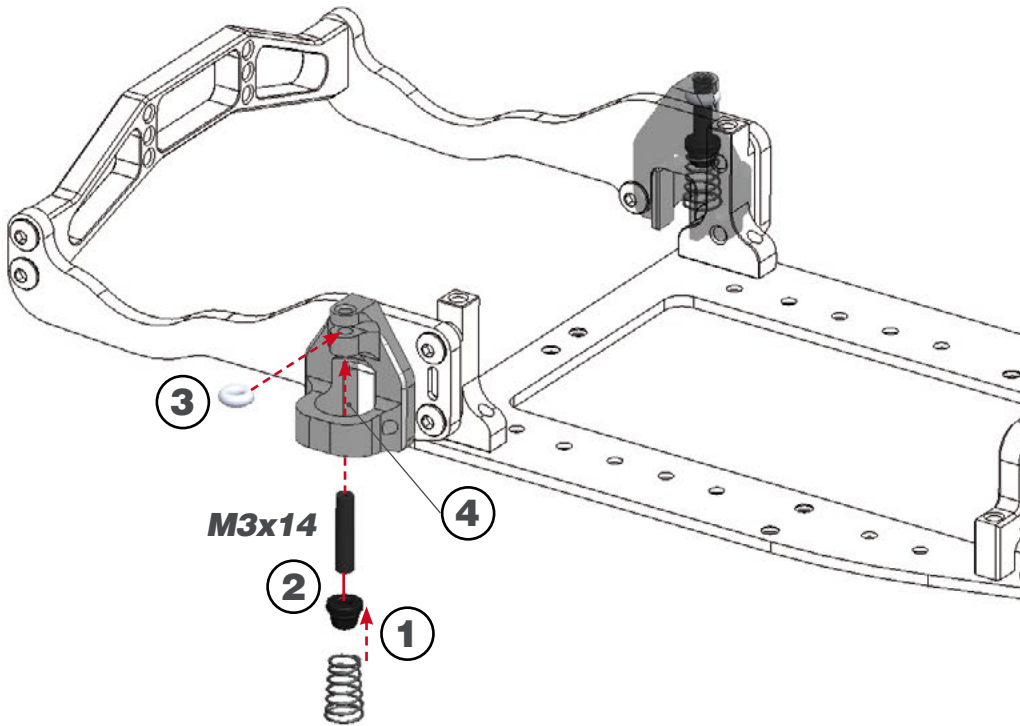

! To exchange the sidesprings it is needed to remove before the bearing holder assembled in step 15.1.

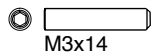

15.1

! To exchange the sidesprings it is needed to remove before the bearing holder.

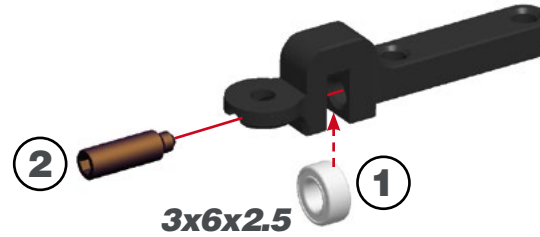

15.2

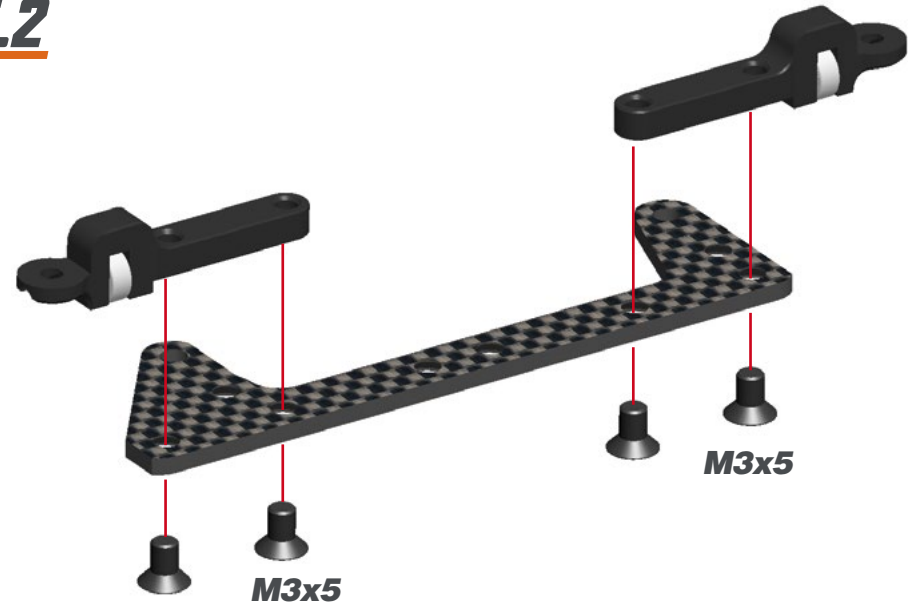

STEP 16

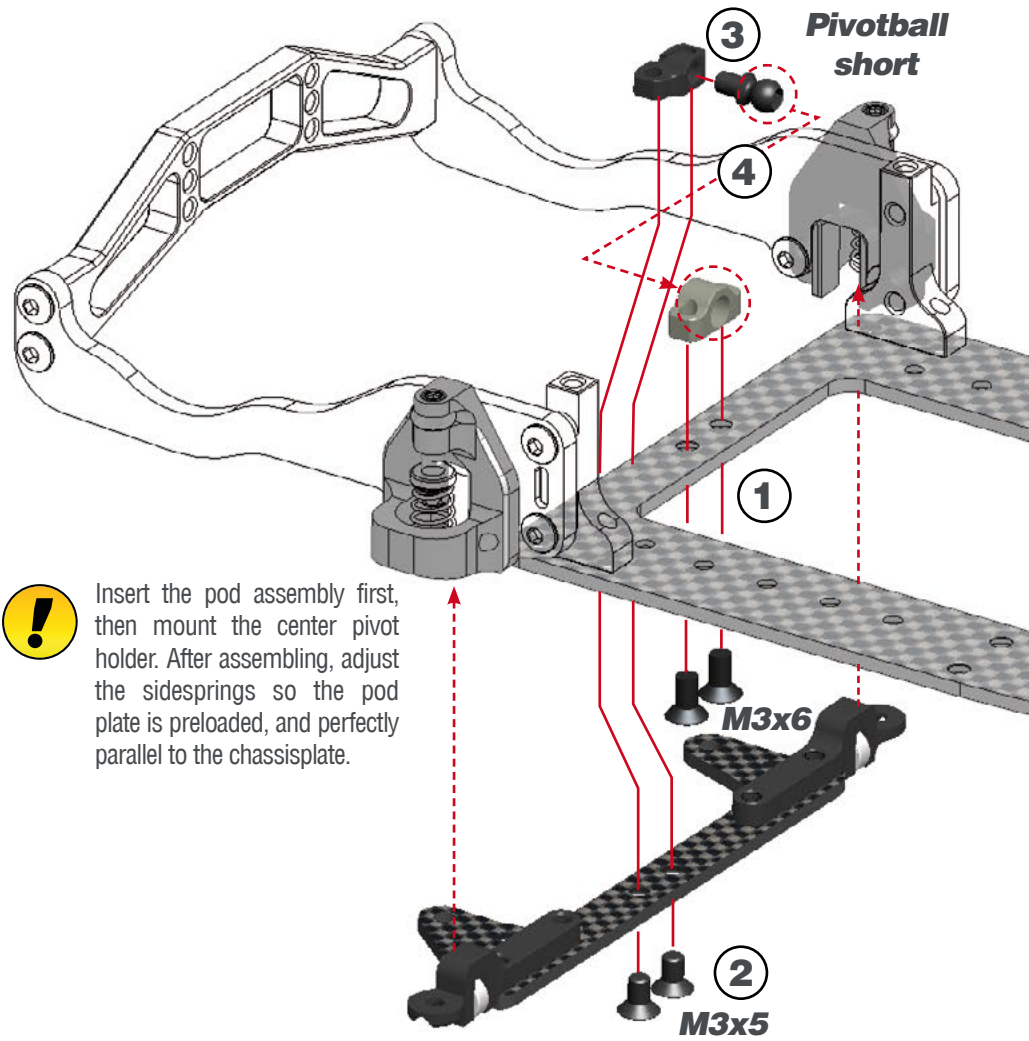

! Insert the pod assembly first, then mount the center pivot holder. After assembling, adjust the sidesprings so the pod plate is preloaded, and perfectly parallel to the chassisplate.



STEP 17

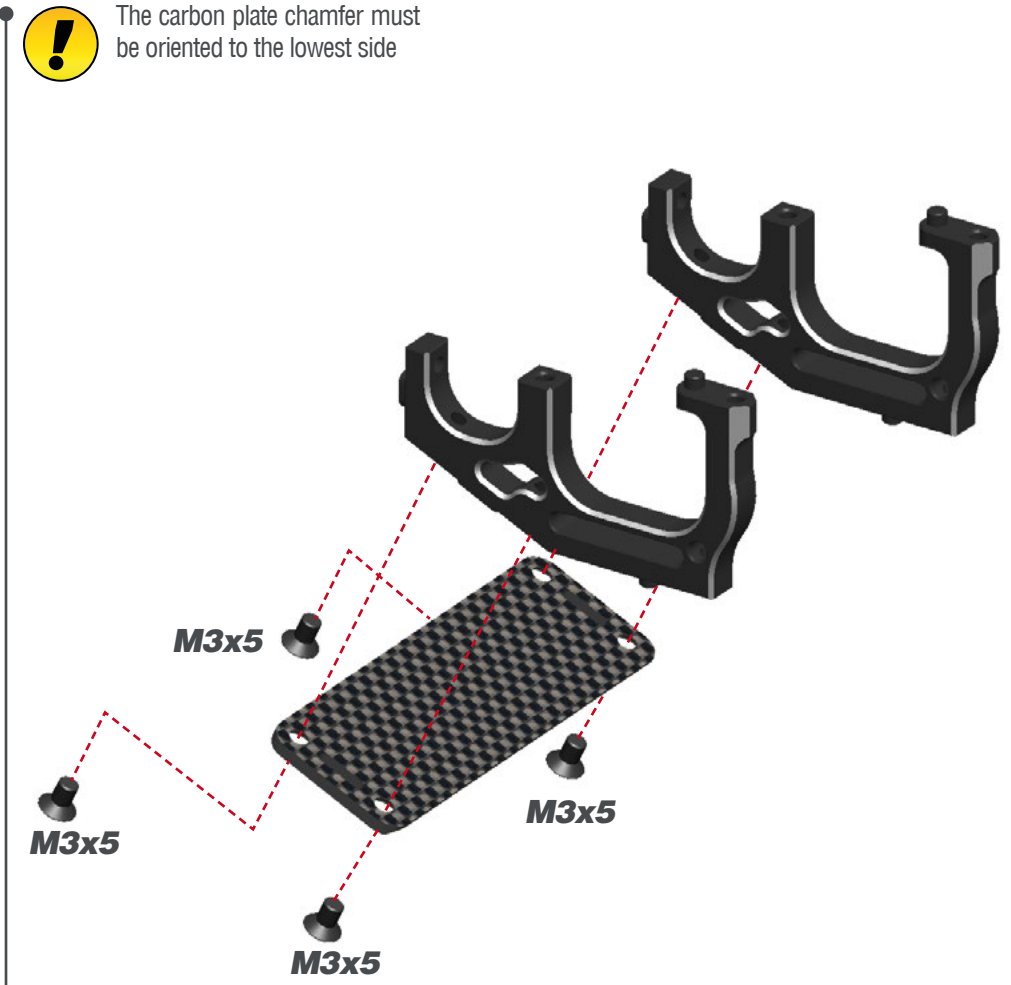

STEP 18

18.1

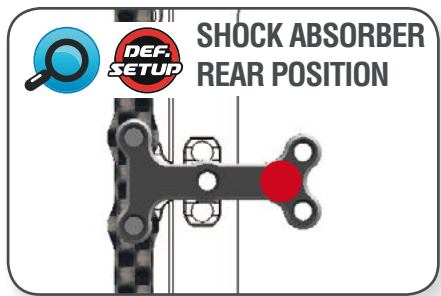
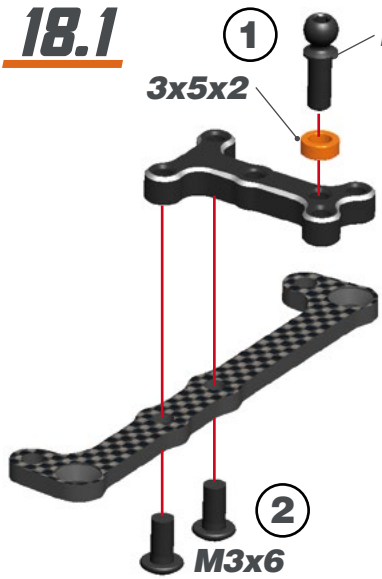

18.2

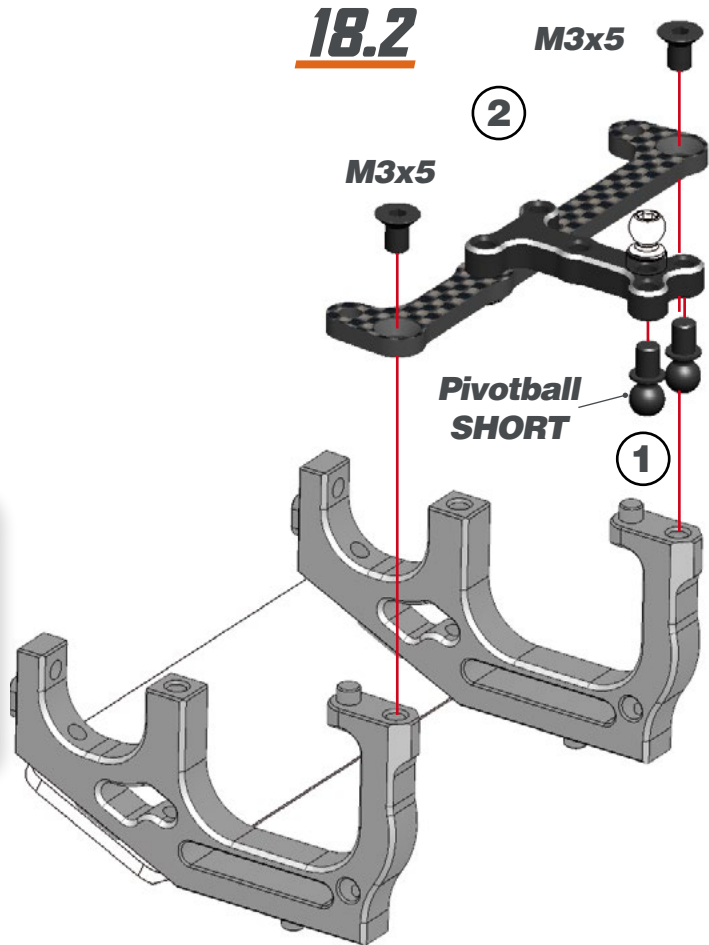

STEP 19

! Both bearing holders are not symmetrical. Right side one fits a 8mm bore ballbearing and the left side one fits a 3/8" bore ball bearing.

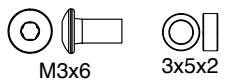
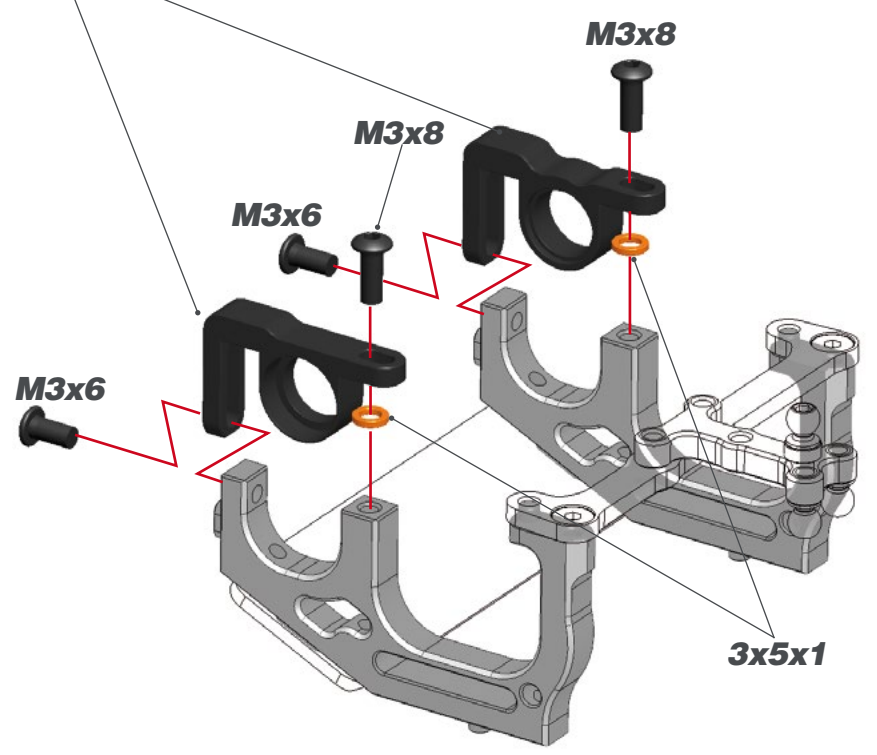

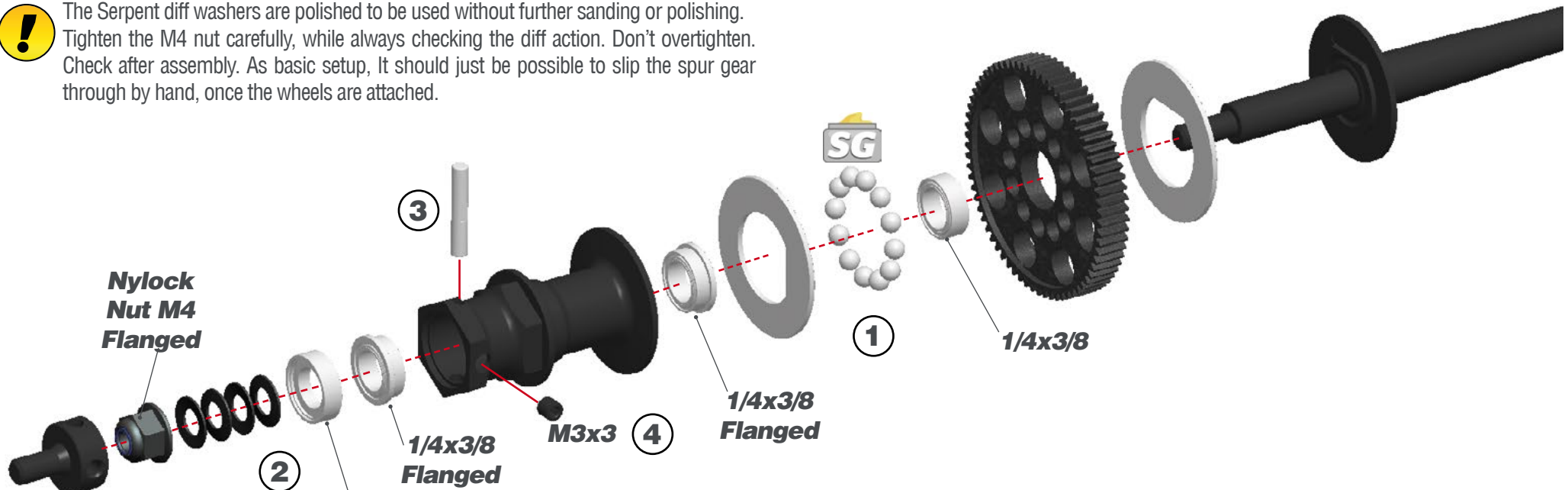

STEP 28 **BAG 5**

! The Serpent diff washers are polished to be used without further sanding or polishing. Tighten the M4 nut carefully, while always checking the diff action. Don't overtighten. Check after assembly. As basic setup, it should just be possible to slip the spur gear through by hand, once the wheels are attached.

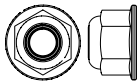

! Note correct shims orientation.

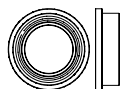
- 
 Nylock Nut
M4 Flanged
- 
 1/4x3/8
- 
 1/4x3/8 Flanged

STEP 21

! The M3x8 special head screw is normally enough to hold the wheelhub. However, if you deem it necessary, you can insert a M3x4 set screw on the other side.

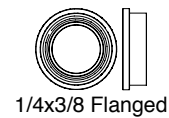
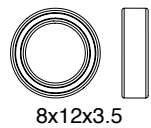
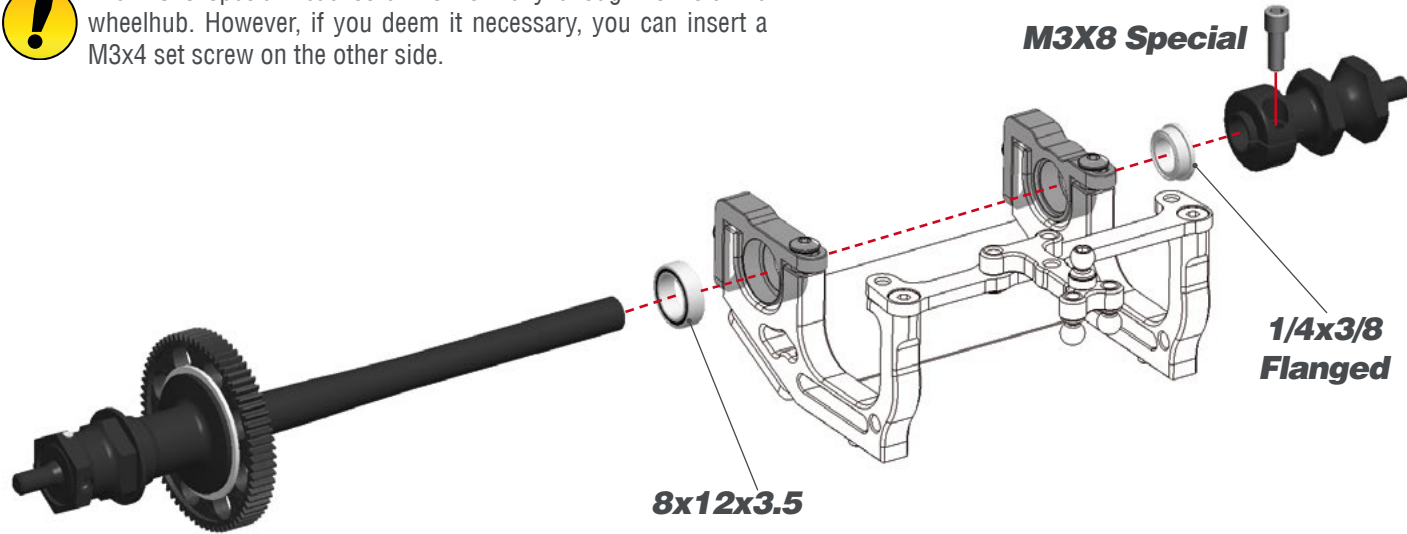

STEP 22

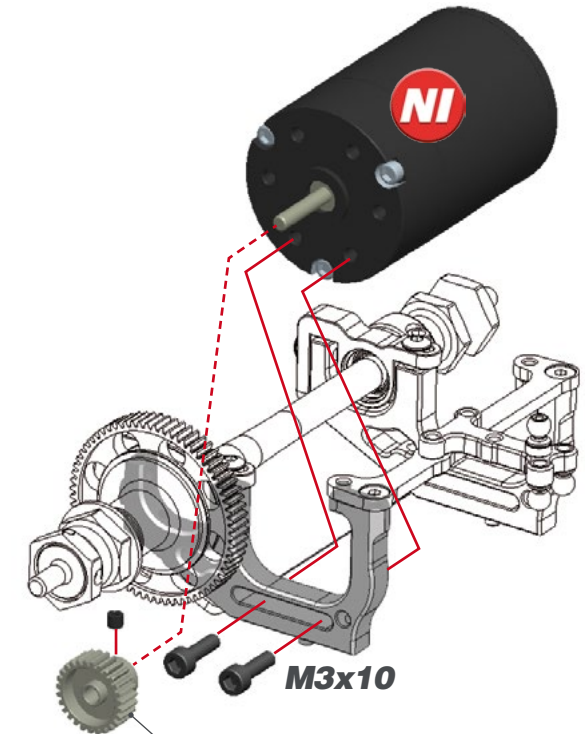

NI ! Pinion is not included in the kit. Assemble the proper pinion for your set-up.



STEP 23

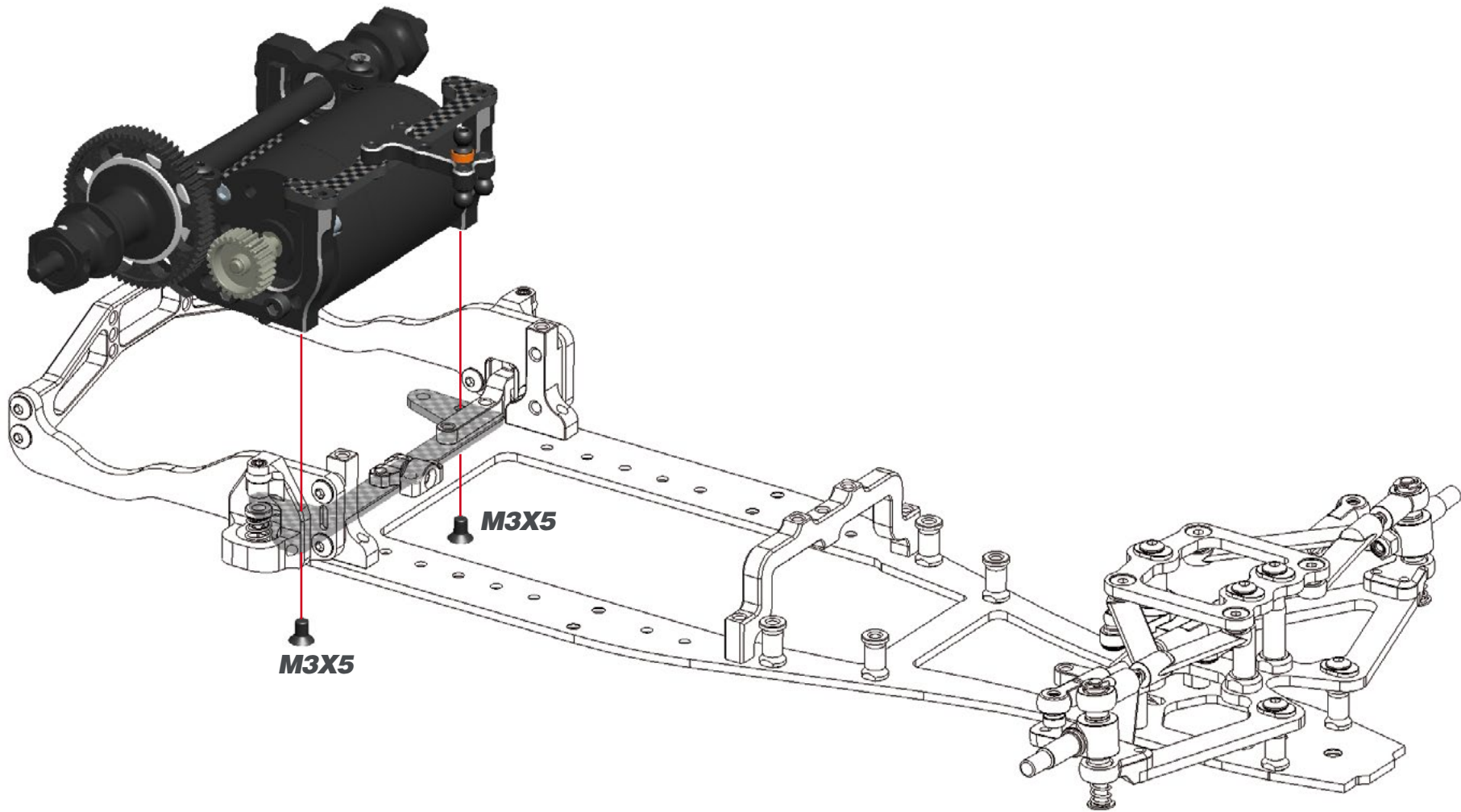

STEP 24 BAG 6

HIGH TRACTION CONFIGURATION **DEFAULT**



Recommended for indoor racing and treated track surfaces (for example sugarwater).

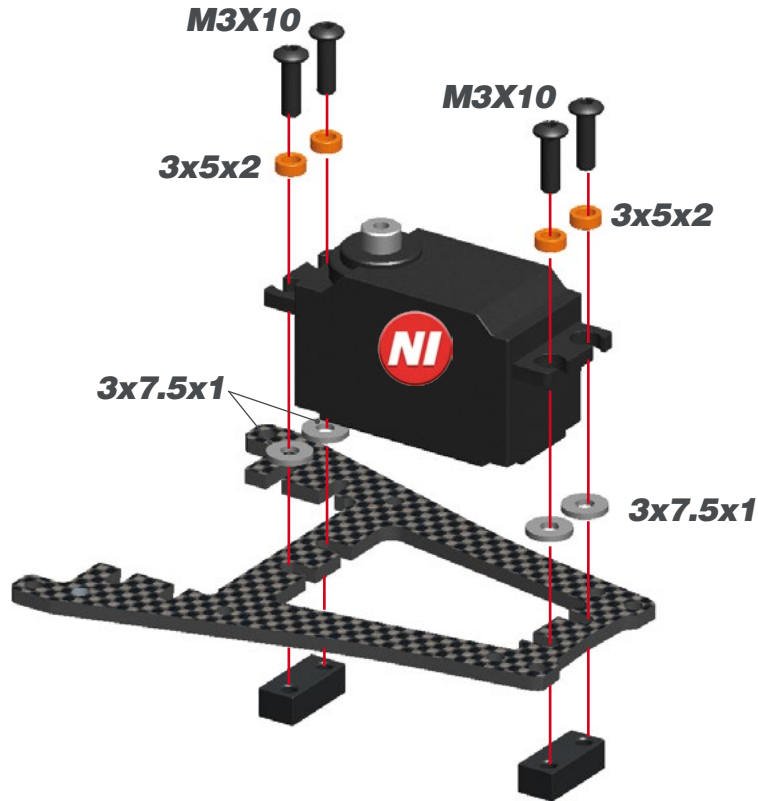

LOW TRACTION CONFIGURATION **OPTIONAL**



Recommended for general outdoor use

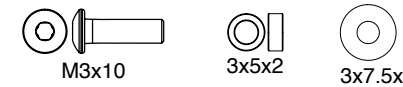
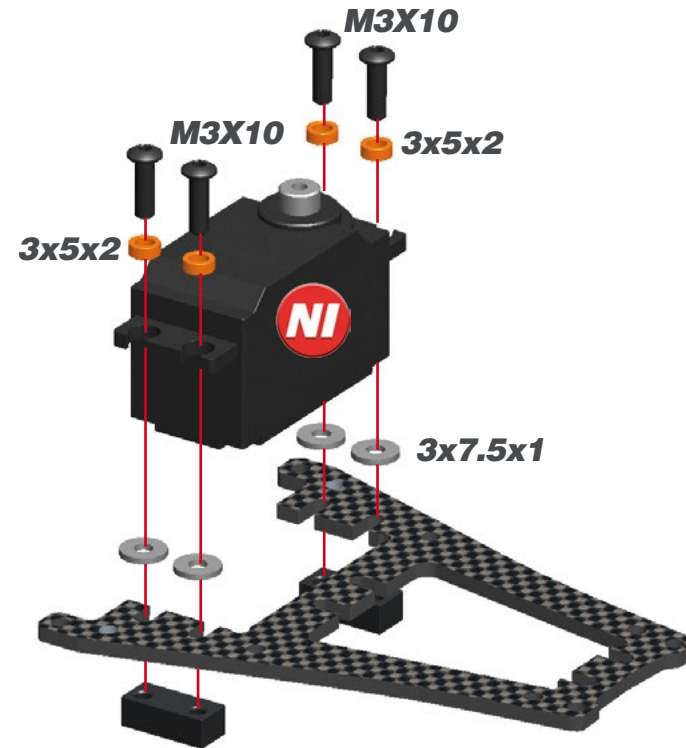

STEP 25

HIGH TRACTION CONFIGURATION *DEFAULT*

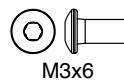
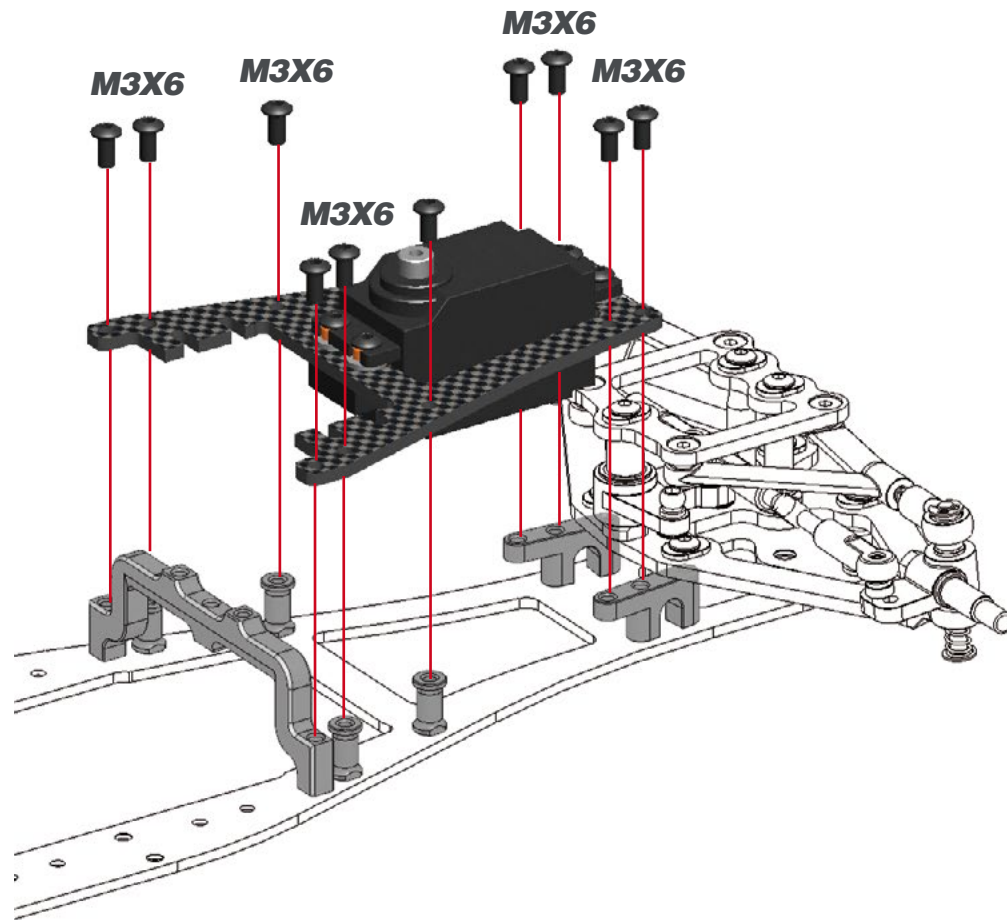

LOW TRACTION CONFIGURATION *OPTIONAL*

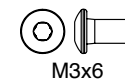
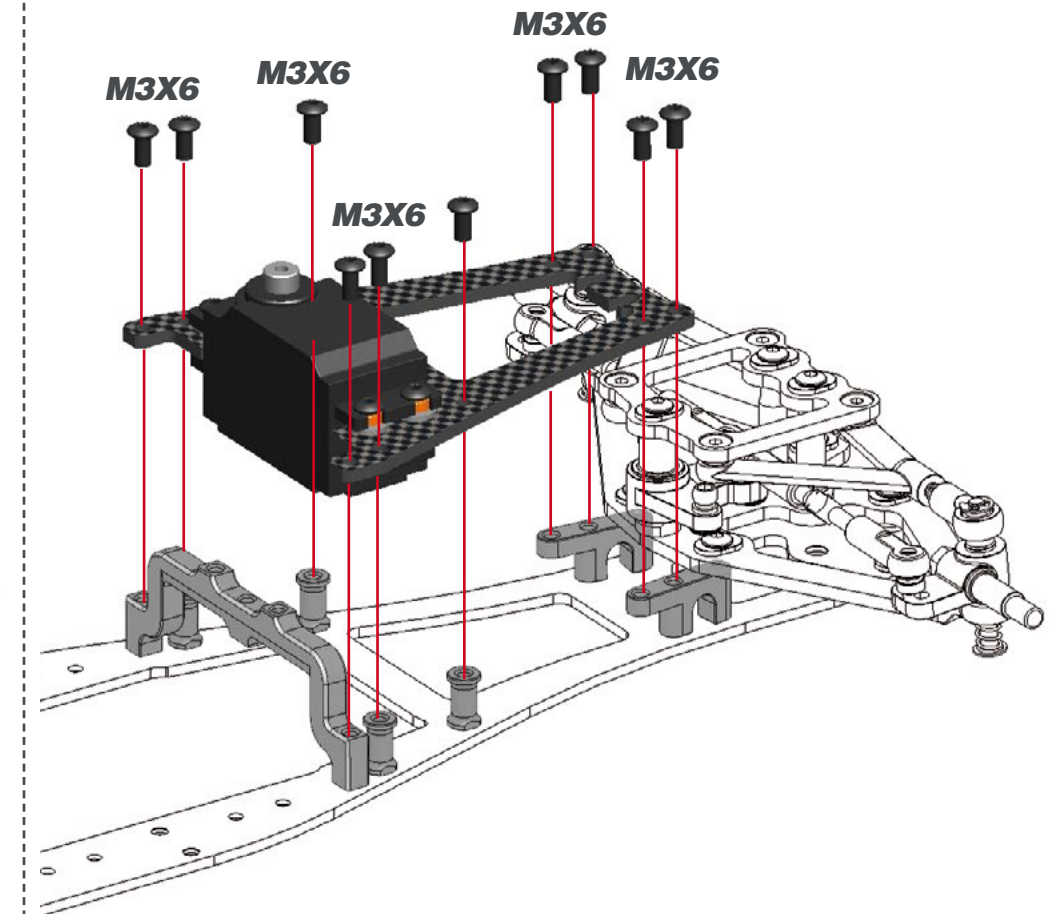

STEP 26

HIGH TRACTION CONFIGURATION *DEFAULT*

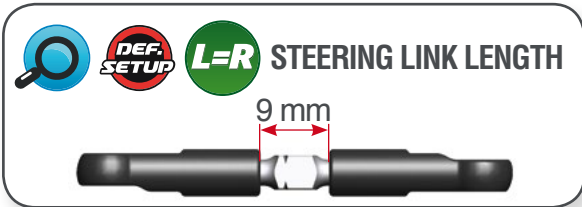
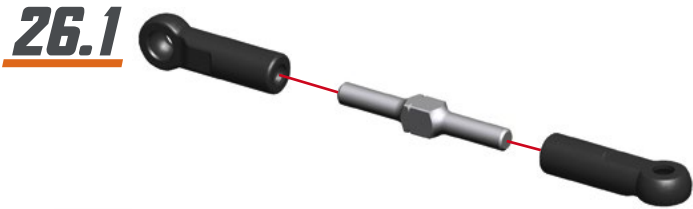

26.2

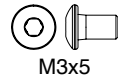
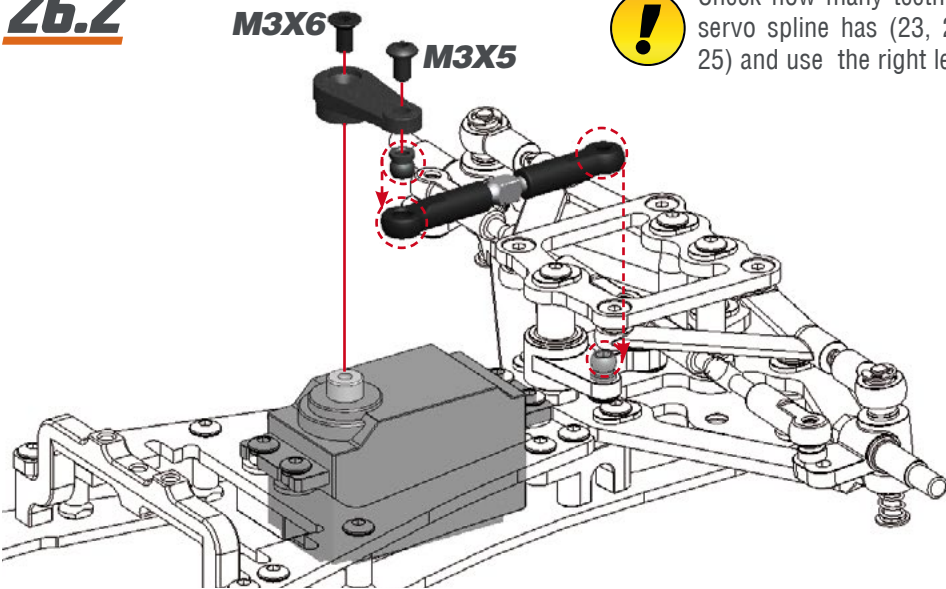

LOW TRACTION CONFIGURATION *OPTIONAL*

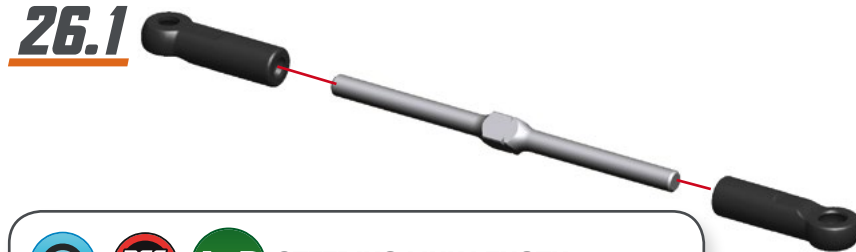

26.2

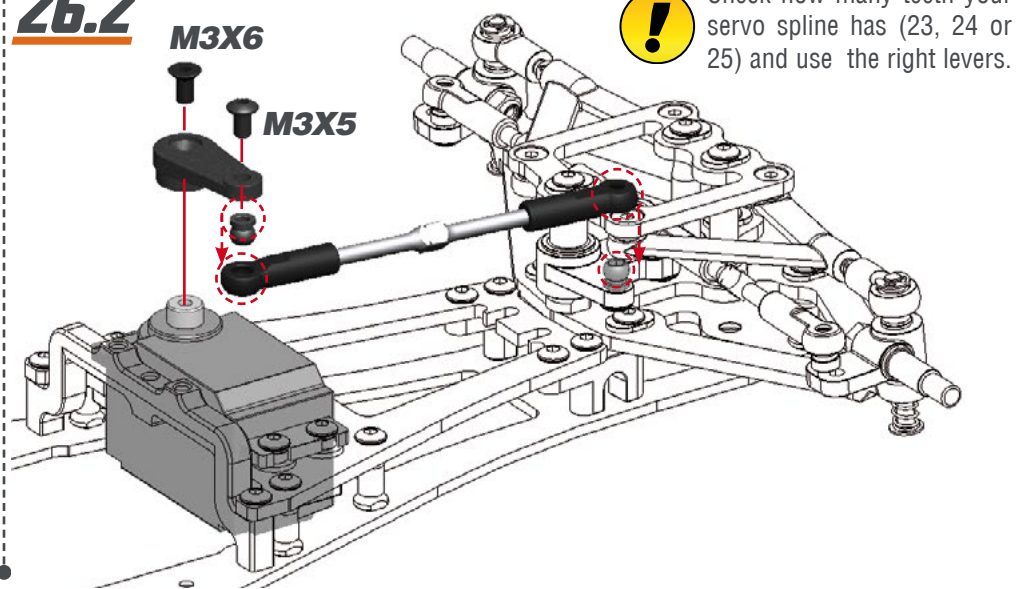

STEP 27 **BAG 7**

HIGH TRACTION CONFIGURATION *DEFAULT*

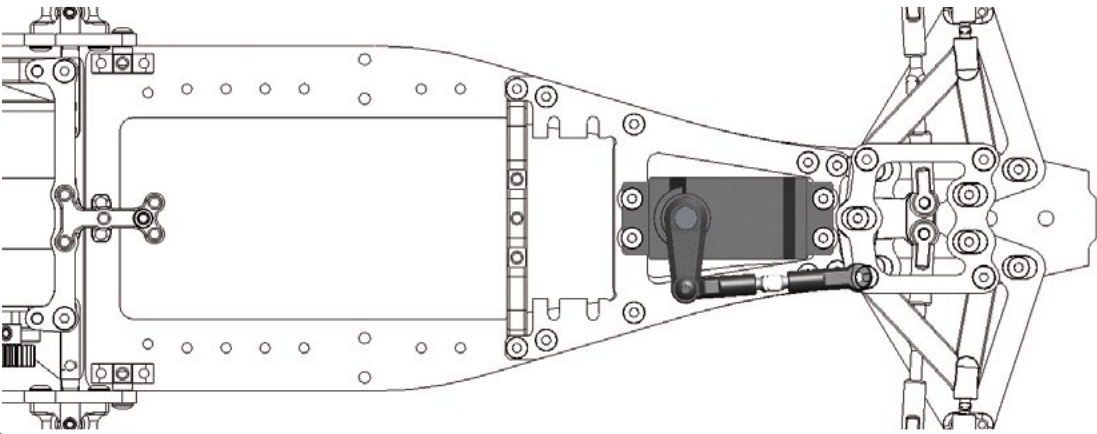

LOW TRACTION CONFIGURATION *OPTIONAL*

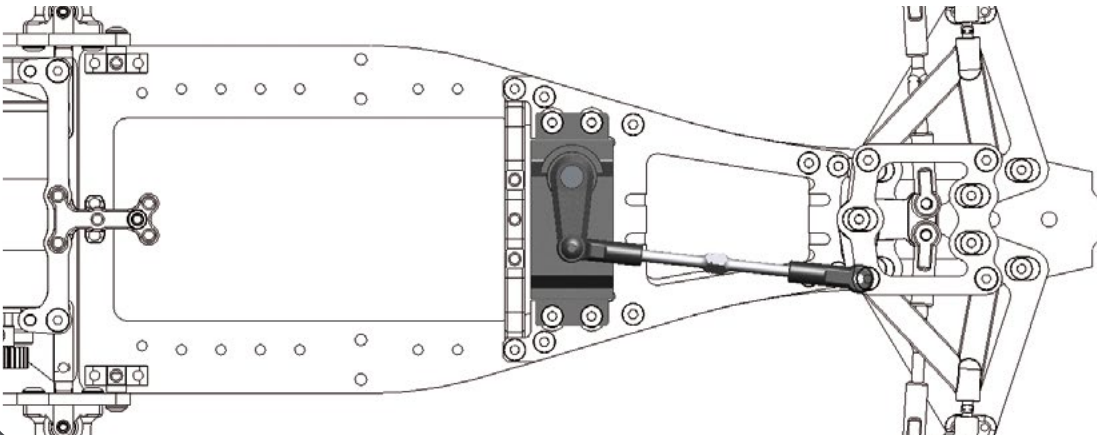

If your bodyshell has a vertical surface under the inside initial bodyholder position, use the outside position

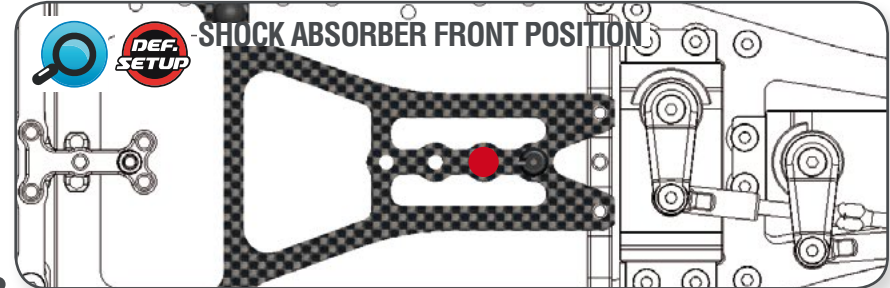
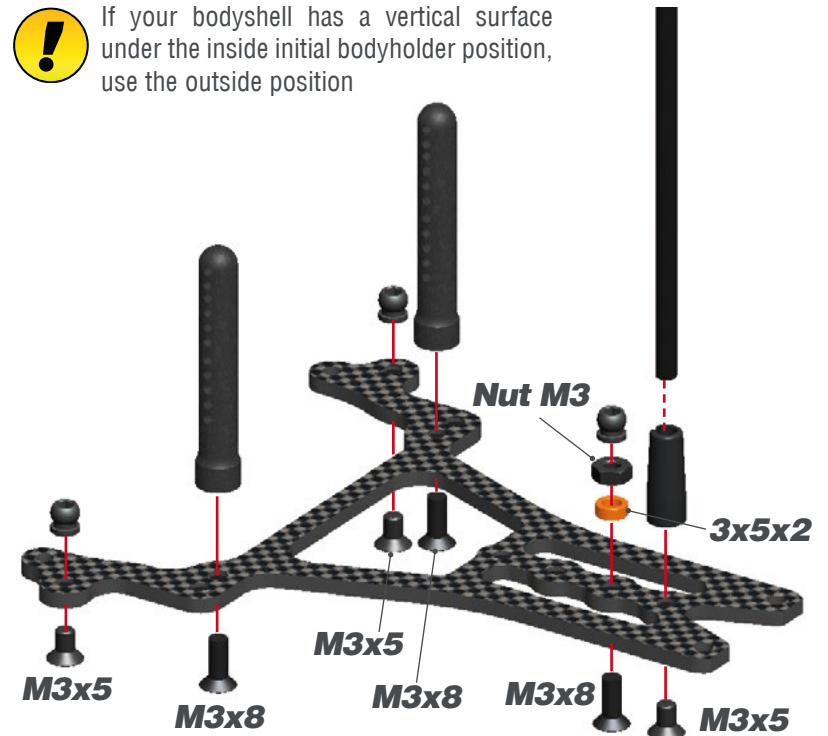

STEP 28

STEP 29

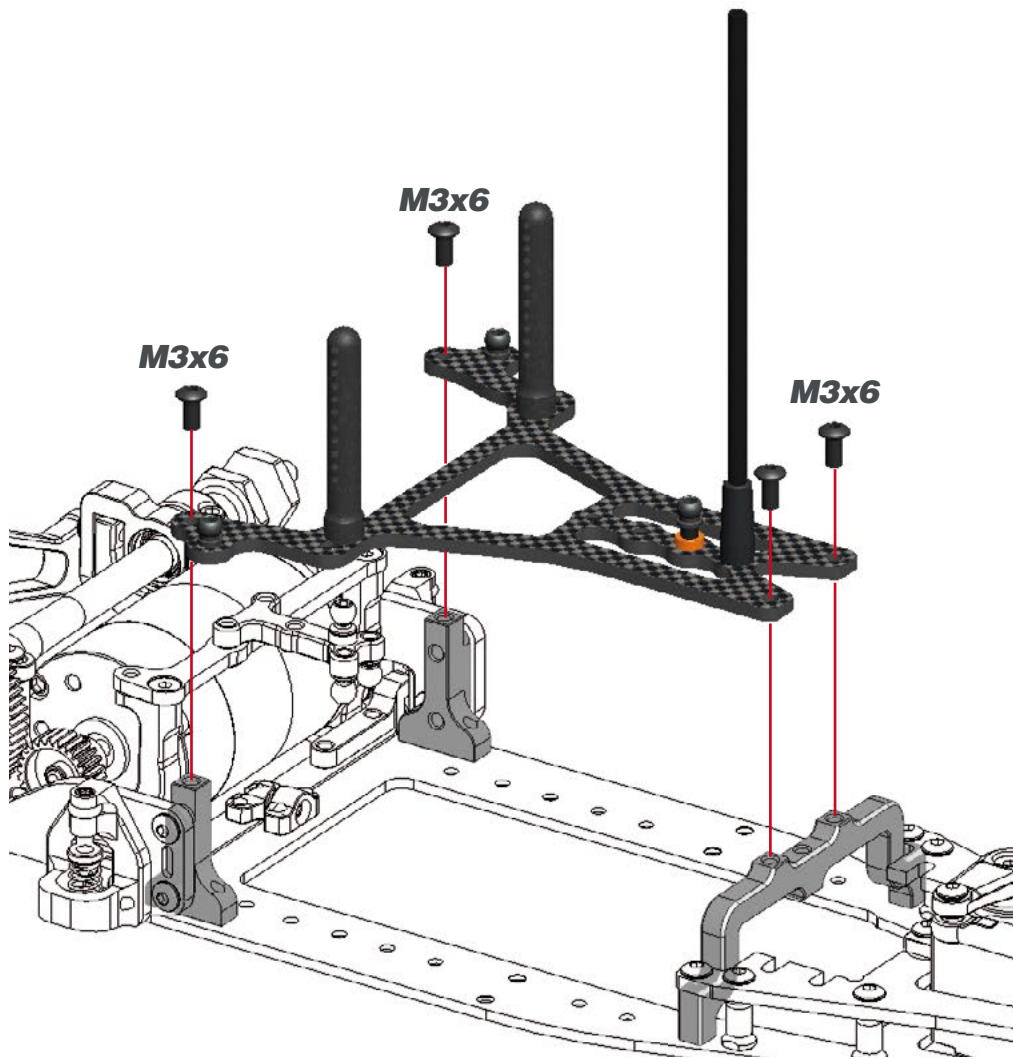

M3x6

M3x6

M3x6

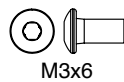

29.1

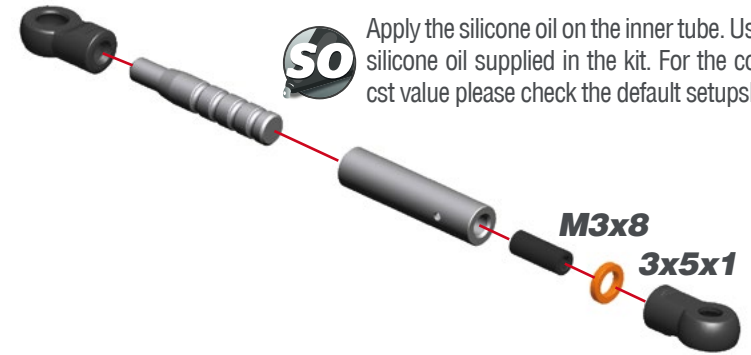

Apply the silicone oil on the inner tube. Use the silicone oil supplied in the kit. For the correct cst value please check the default setupsheet.

M3x8

3x5x1

29.2

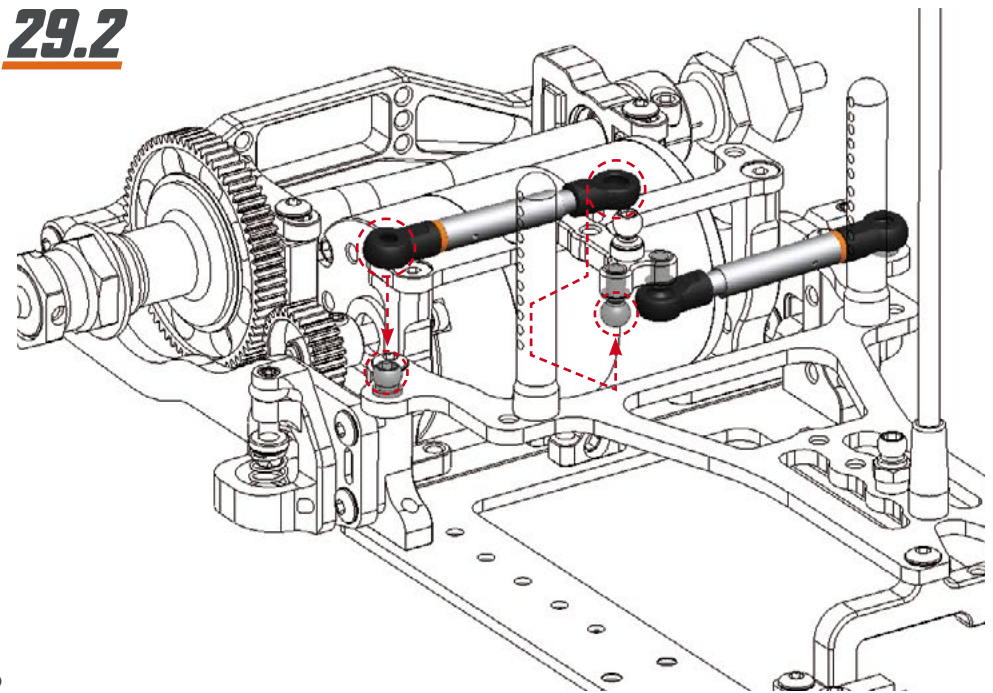

STEP 30 SHOCK BAG

30.1

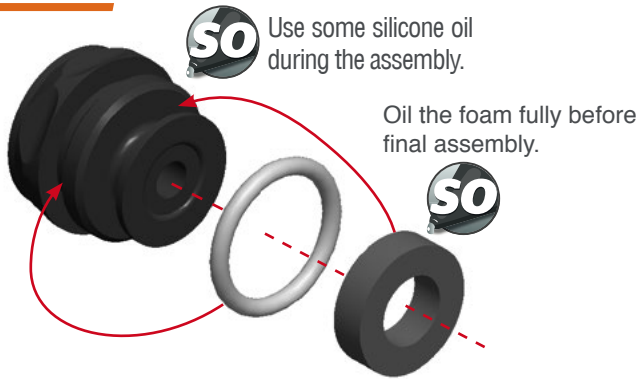

30.2

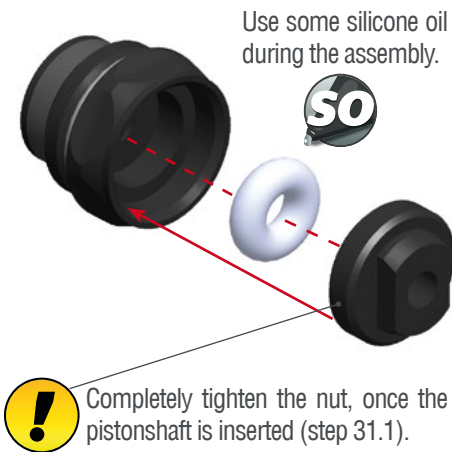

30.3

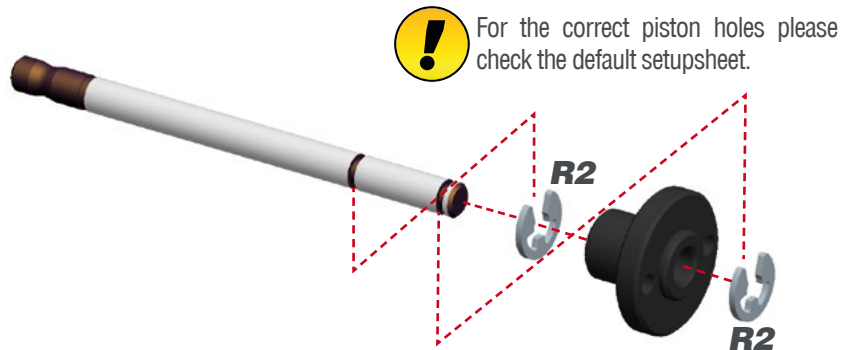

STEP 31

31.1

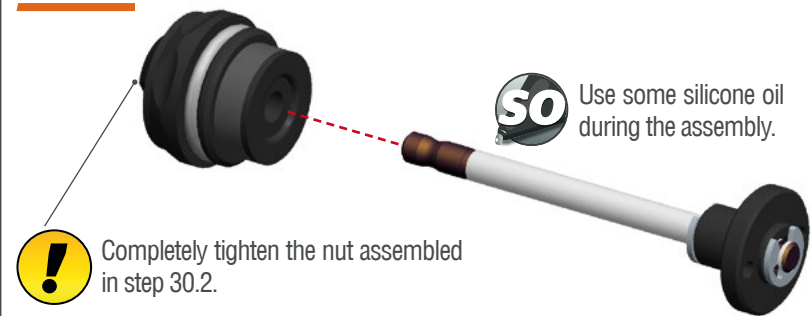

31.2

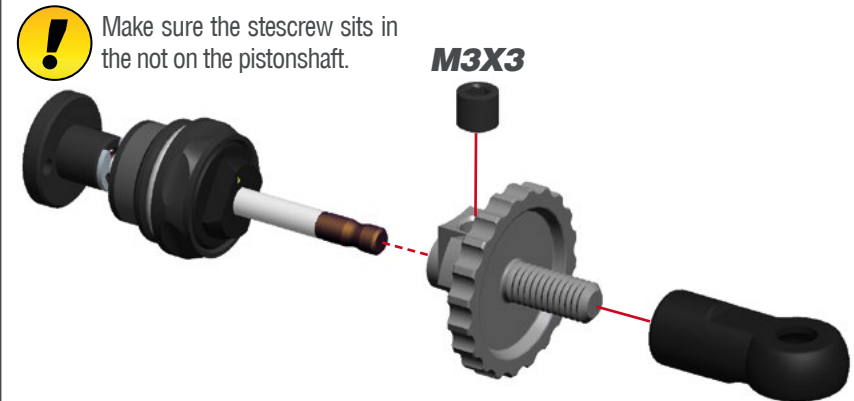

STEP 32

32.1

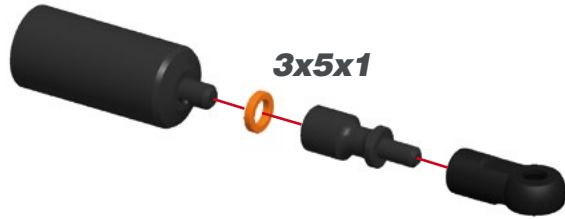

3x5x1

32.2

1) Fill the shock body with shock absorber oil. Check the oil CST value in the setup sheet.

2) Bleeding: Let the oil settle and allow the air to escape.



3x5x1

STEP 33

Close the shock slowly.

Important: do not crossthread! Oil will overflow through the built-in bleed channel.

Tighten carefully until the bottom half sits against the shock body.

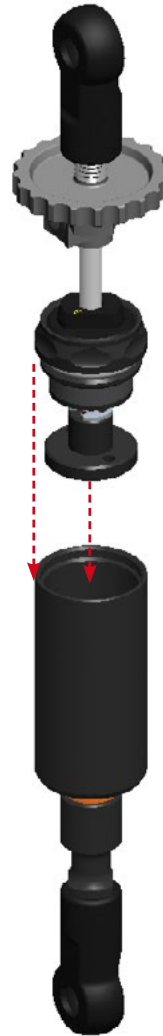

STEP 34

34.1

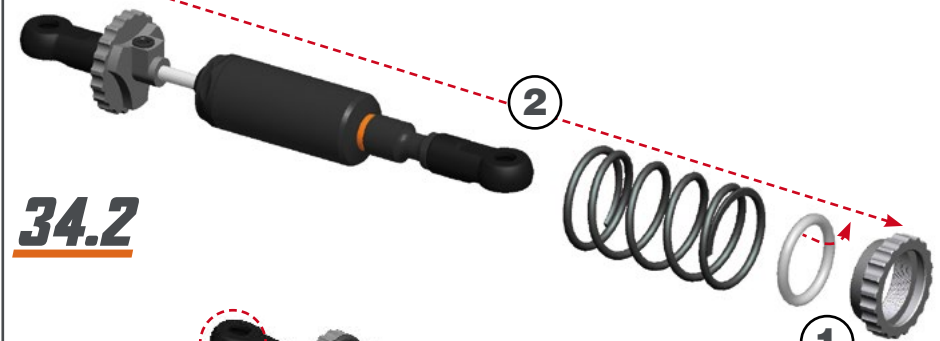

34.2

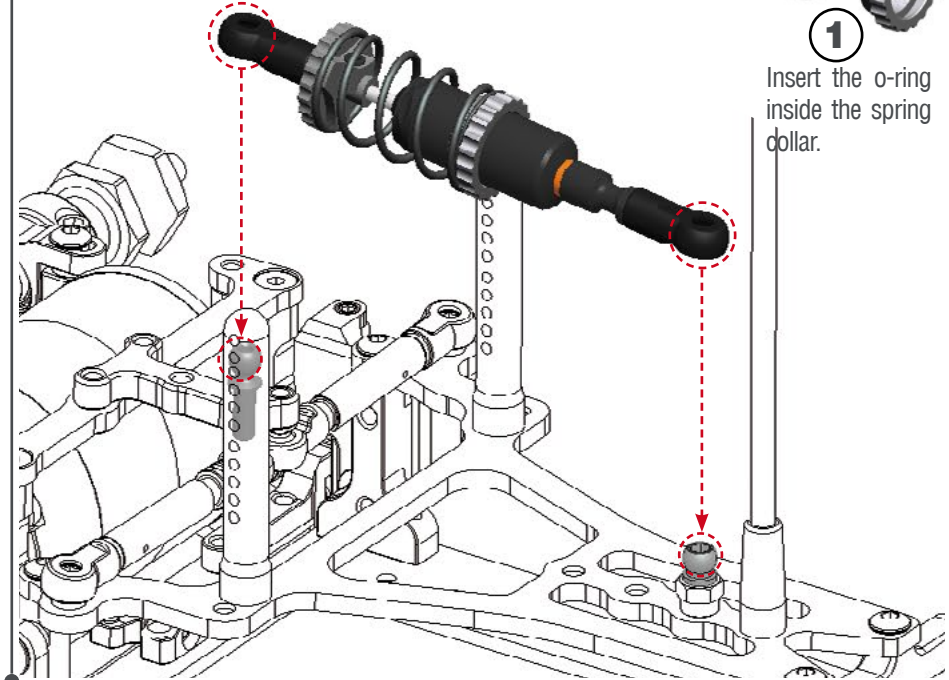

1
Insert the o-ring inside the spring collar.

STEP 35 BAG 8



Use double sided tape to mount the FANS to the chassis.

NI



Use narrow fans that don't touch the pod plate or the battery holder.

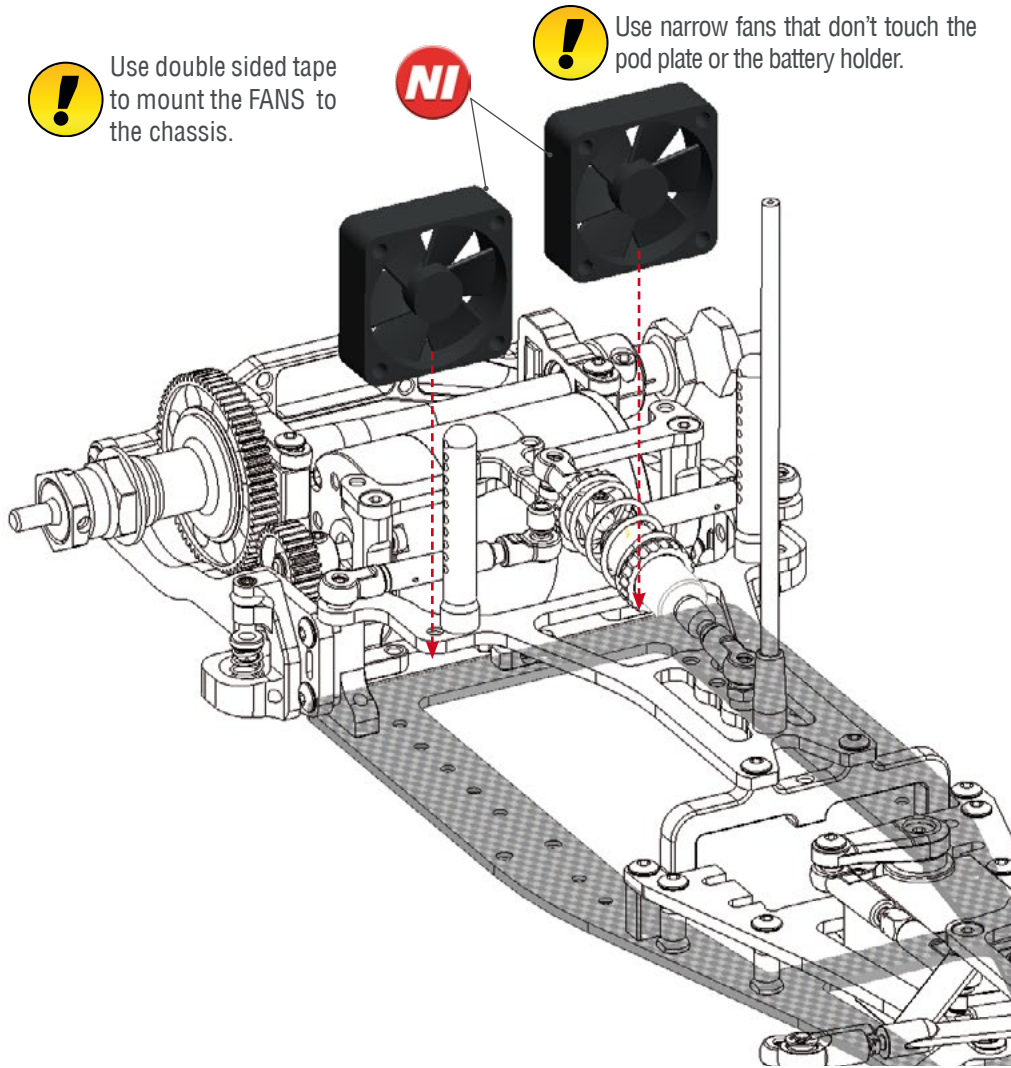

STEP 36

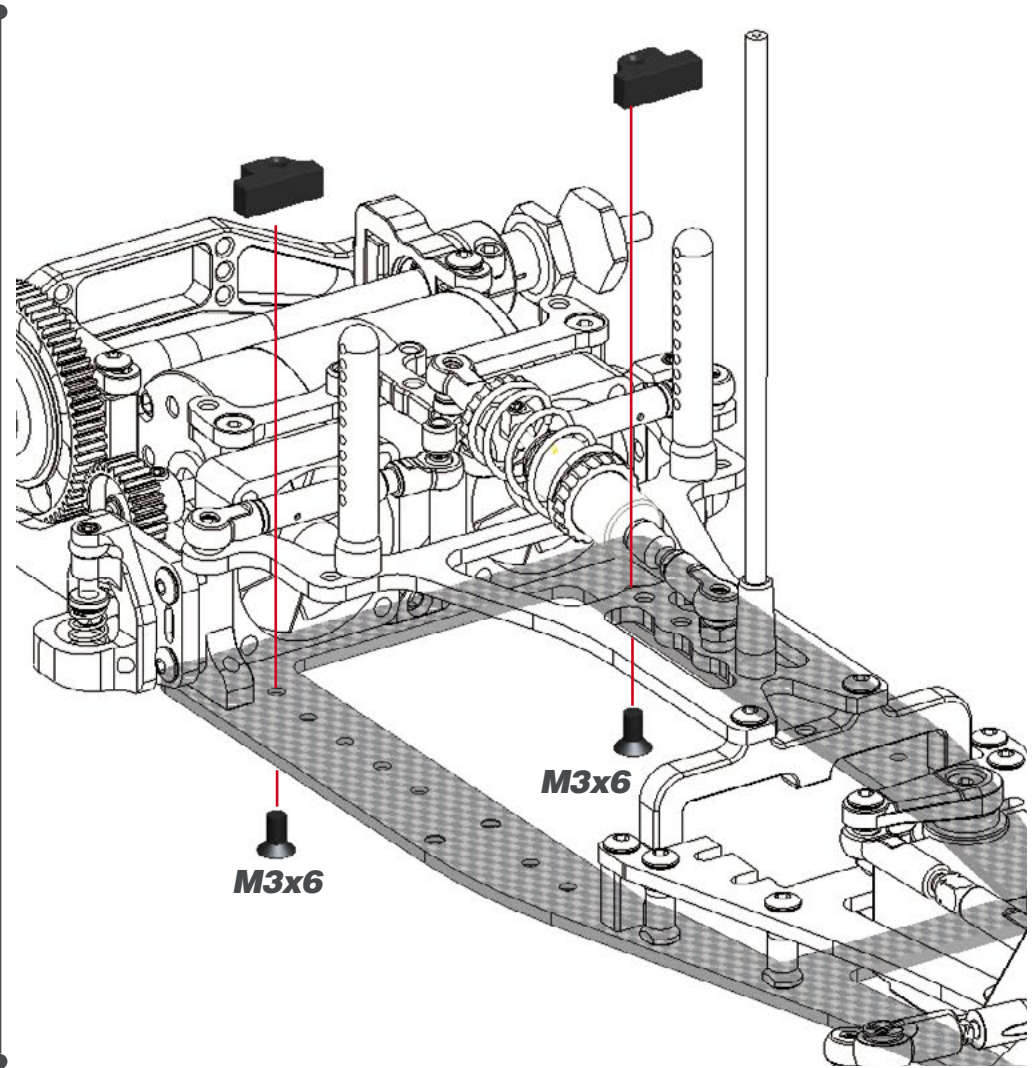

M3x6

STEP 37

HIGH TRACTION CONFIGURATION *DEFAULT*



Recommended for general use.

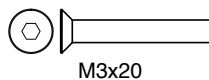
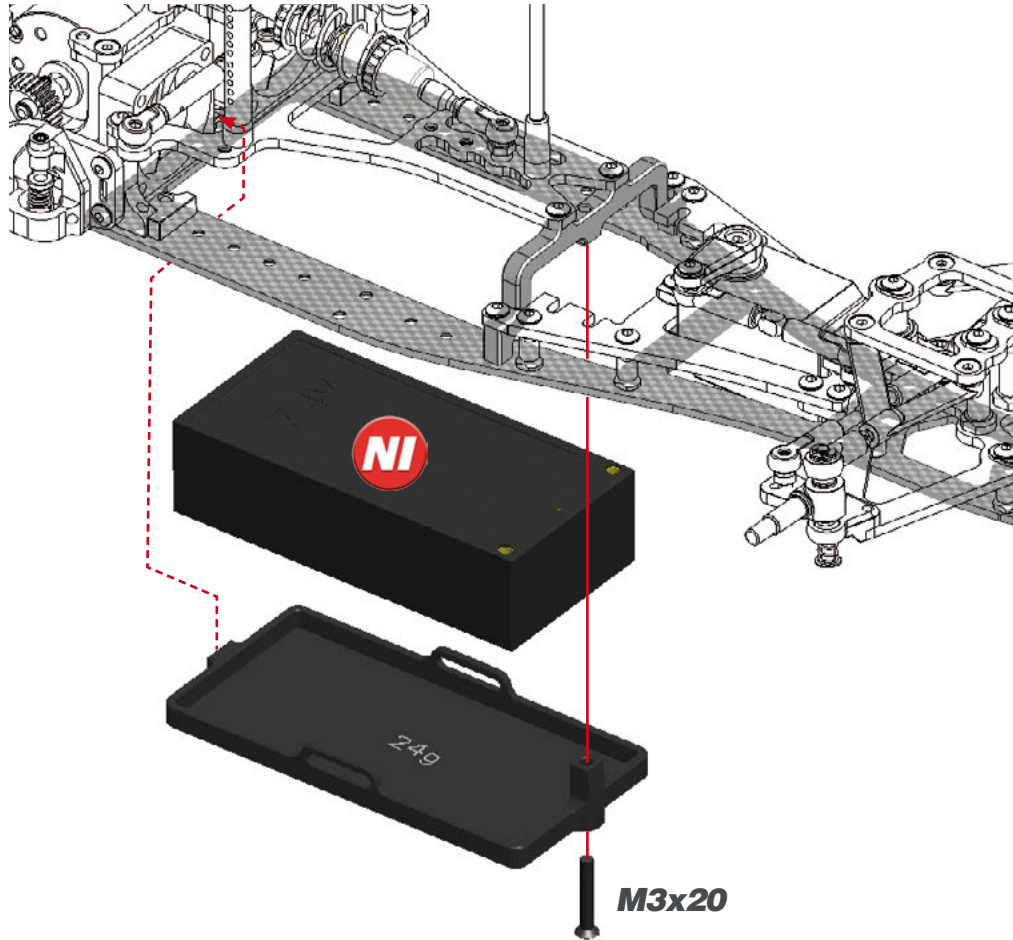

LOW TRACTION CONFIGURATION *OPTIONAL*



recommended for low traction use (dusty asphalt, wet racing).

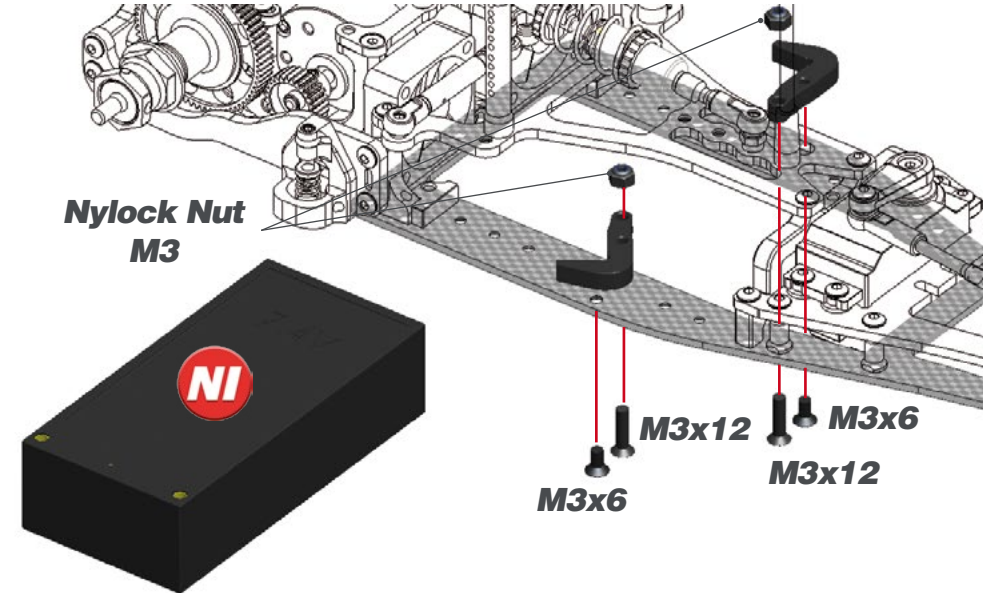

BATTERY MOUNT POSITION

To assemble the battery it is needed to remove the M3x6 screw and turn the battery holder. When the battery will be fitted assemble the M3x6 screw.

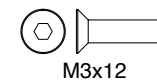
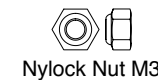
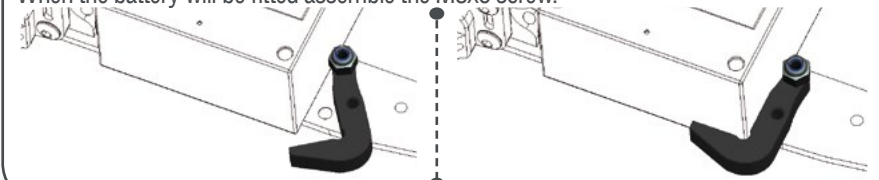

STEP 38

HIGH TRACTION CONFIGURATION *DEFAULT*



Use double sided tape to mount the ESC and RX to the chassis.

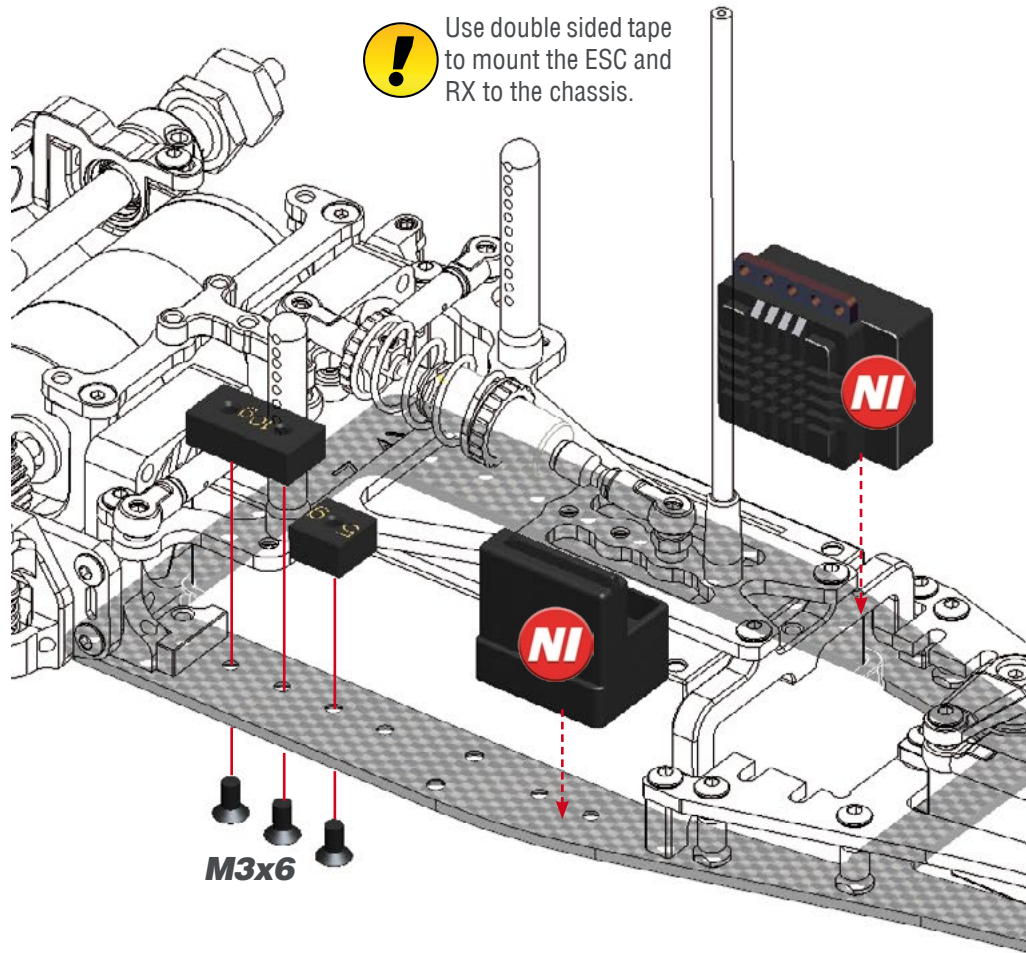

M3x6



M3x6

LOW TRACTION CONFIGURATION *OPTIONAL*

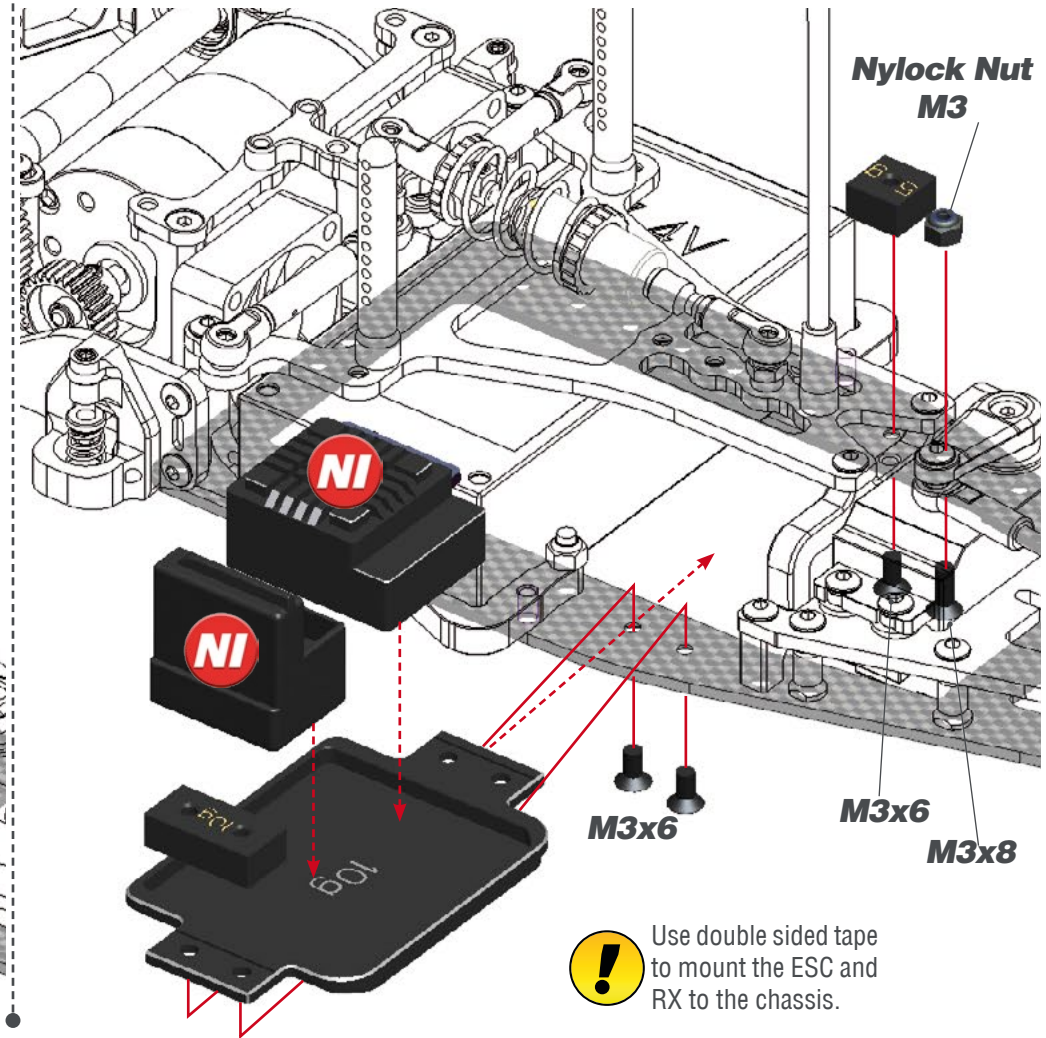

Nylock Nut
M3



Use double sided tape to mount the ESC and RX to the chassis.

M3x6

M3x6

M3x8



M3x6



Nylock Nut M3



M3x8

STEP 39 BAG 9

FRONT WING ASSEMBLY **DEFAULT**

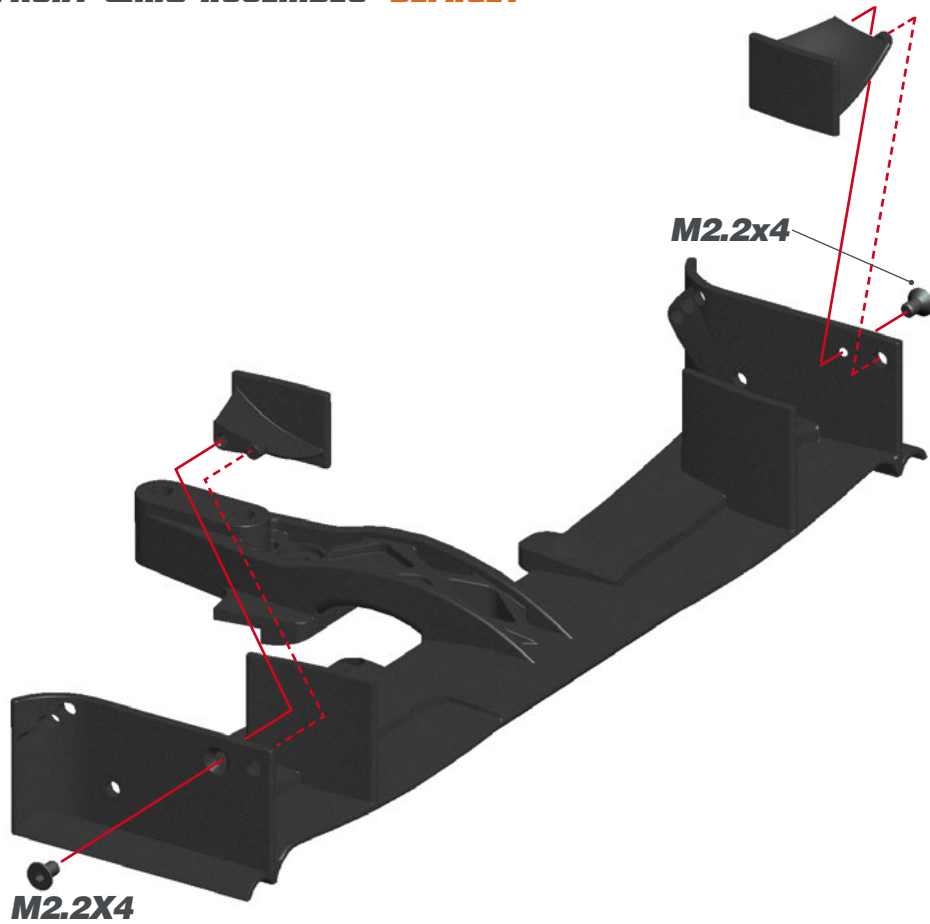

FRONT WING **BIG FLAPS ASSEMBLY** **OPTIONAL**



The front big flaps create a big amount of downforce. It is recommended not to assemble them as default and use them when more steering is needed. Also it is possible to cut them to adjust the amount of downforce created.

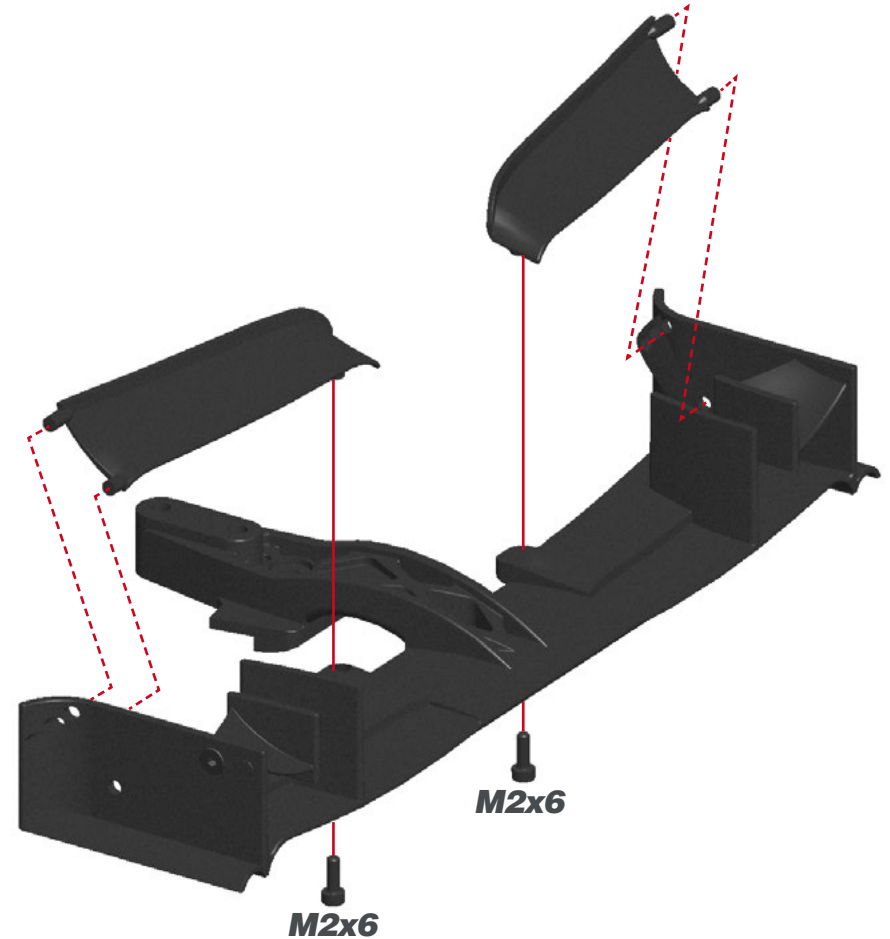

STEP 40

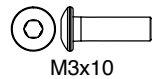
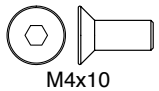
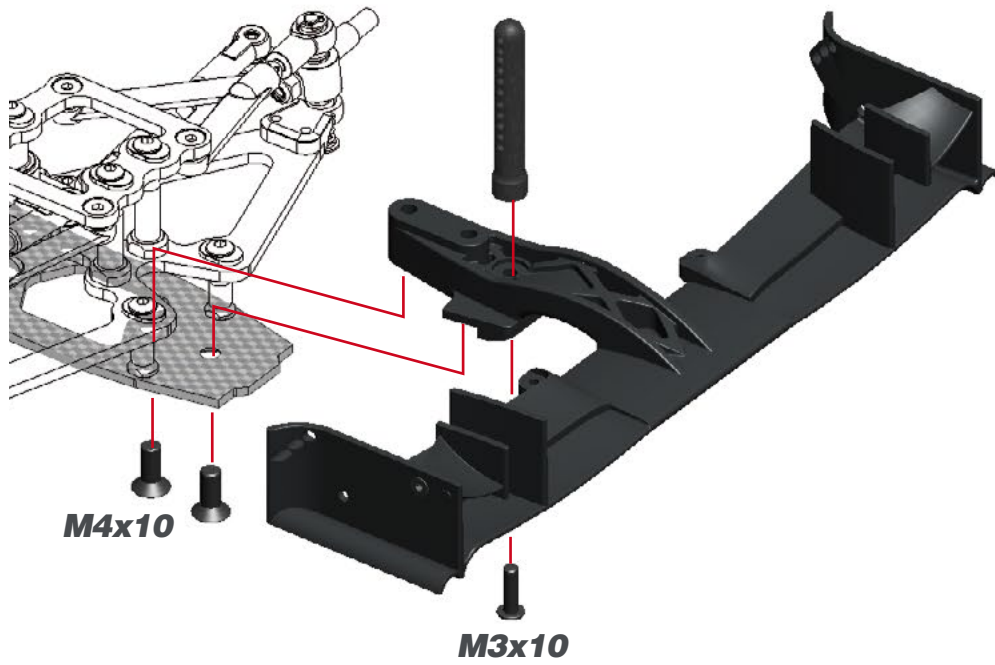

STEP 41 **BAG 10**

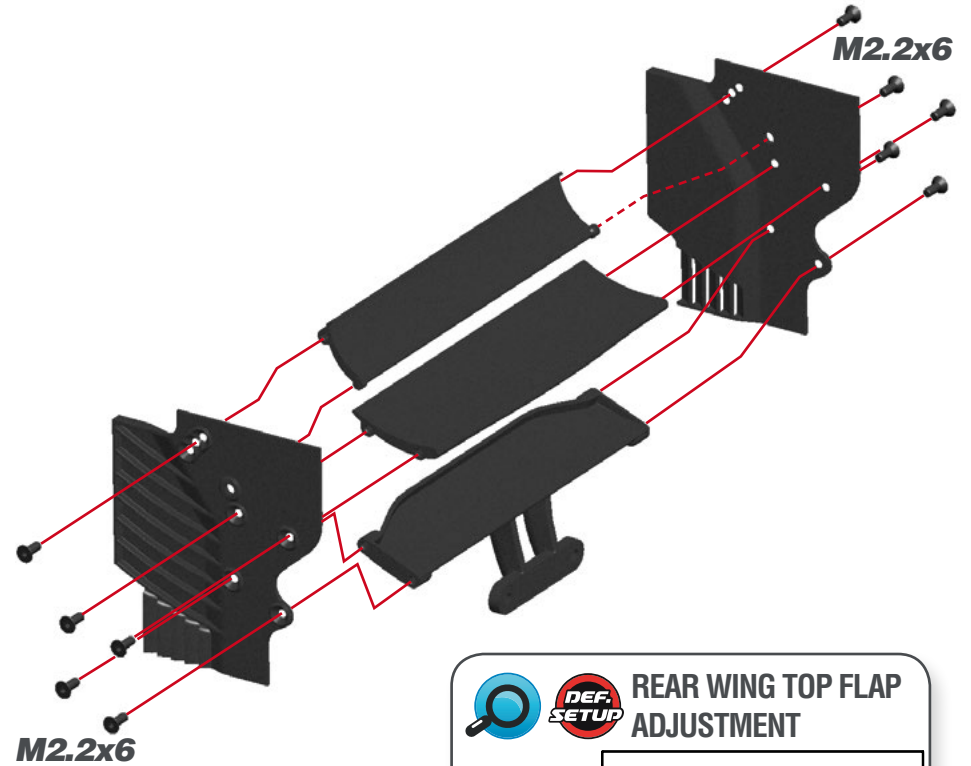

STEP 42

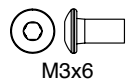
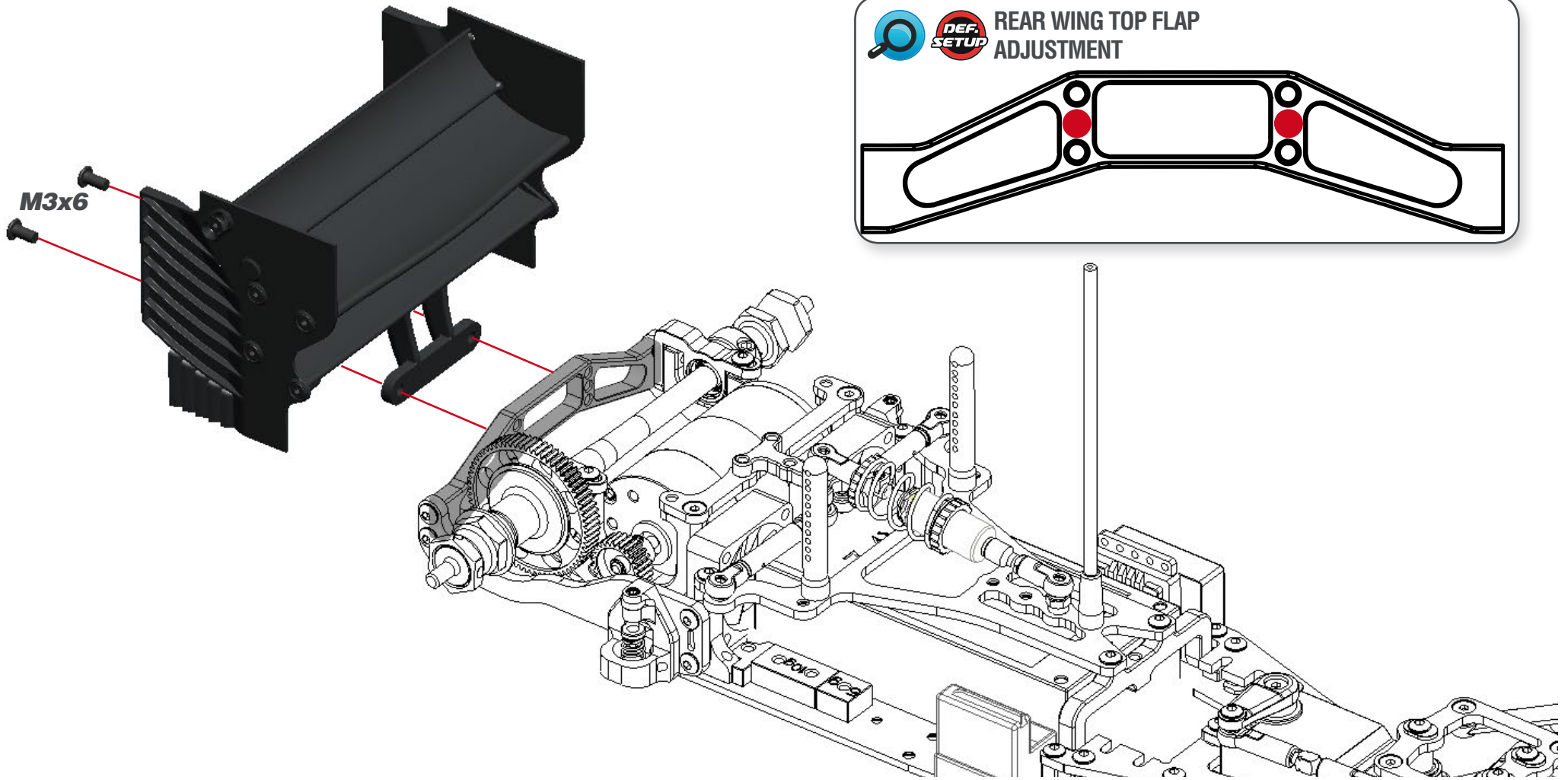

STEP 43

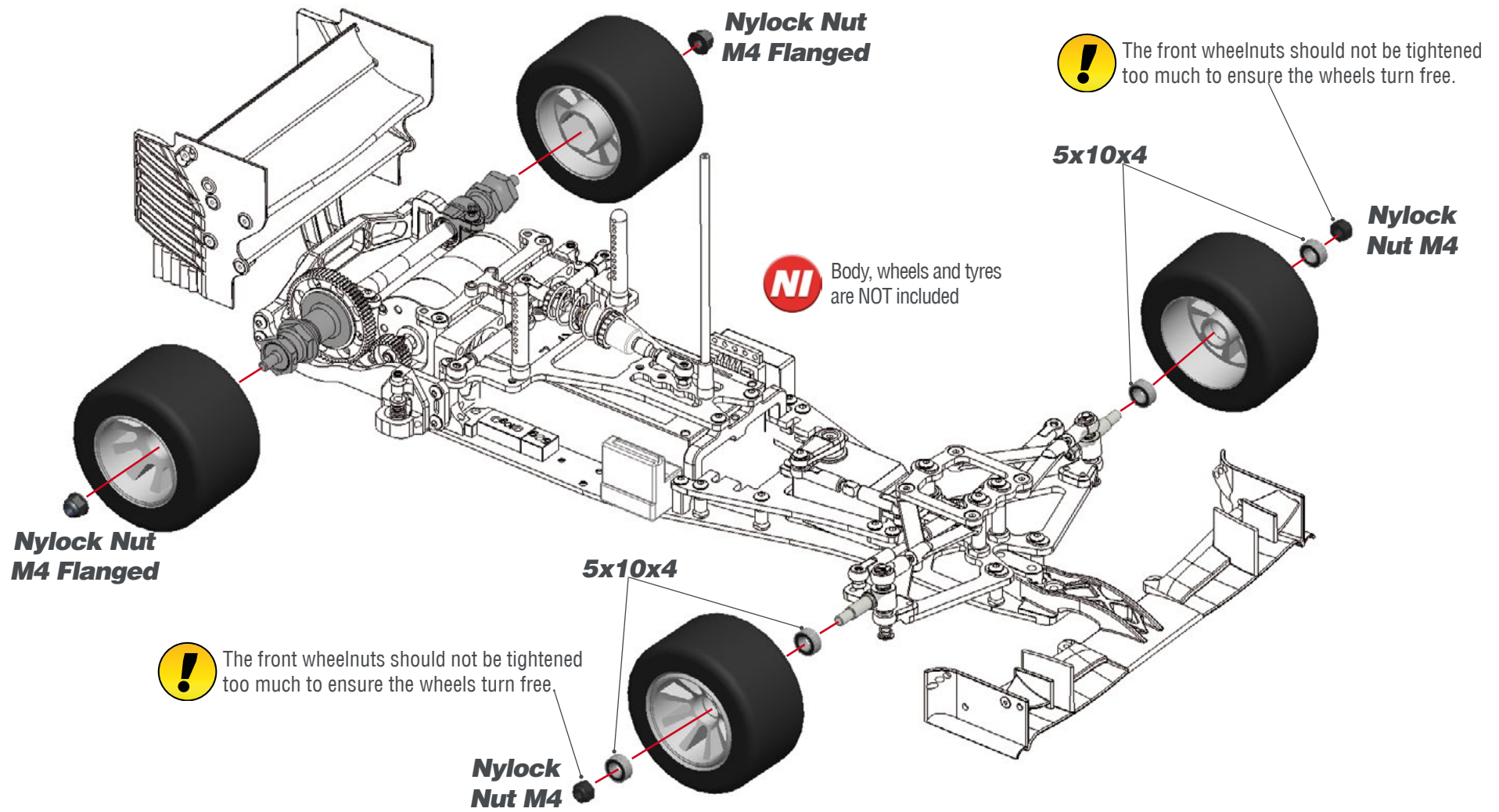

INDEX

<i>FRONT EXPLODED VIEW</i>	<i>32</i>
<i>BALL DIFF EXPLODED VIEW</i>	<i>33</i>
<i>REAR EXPLODED VIEW</i>	<i>34</i>
<i>SHOCK EXPLODED VIEW</i>	<i>35</i>
<i>CENTER EXPLODED VIEW</i>	<i>36</i>
<i>FINAL EXPLODED VIEW</i>	<i>37</i>
<i>TEAM SERPENT NETWORK</i>	<i>38</i>

FRONT EXPLODED VIEW

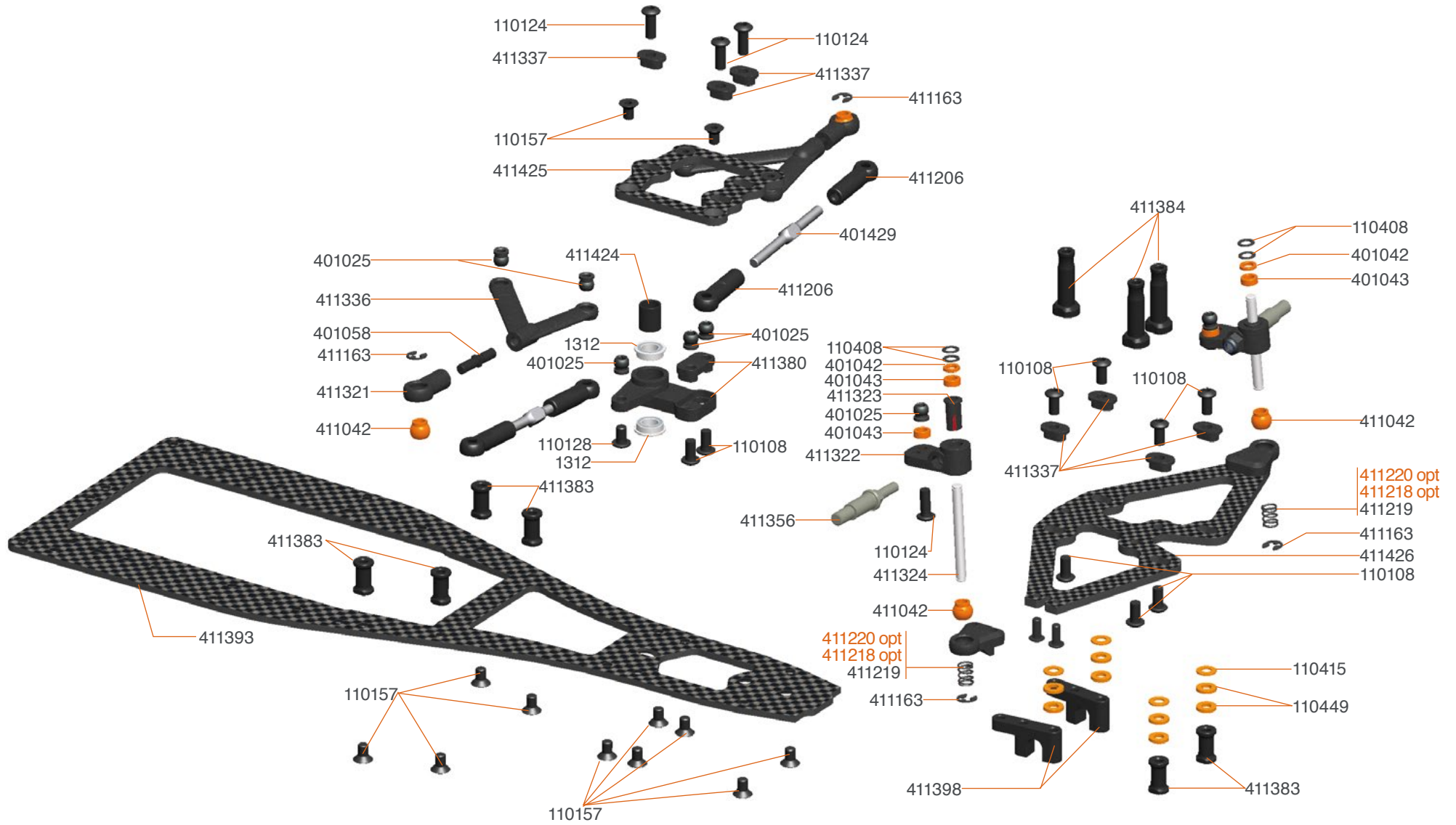

- 411218 Front spring 22lbs S120L (2)
- 411220 Front spring 26lbs S120L (2)



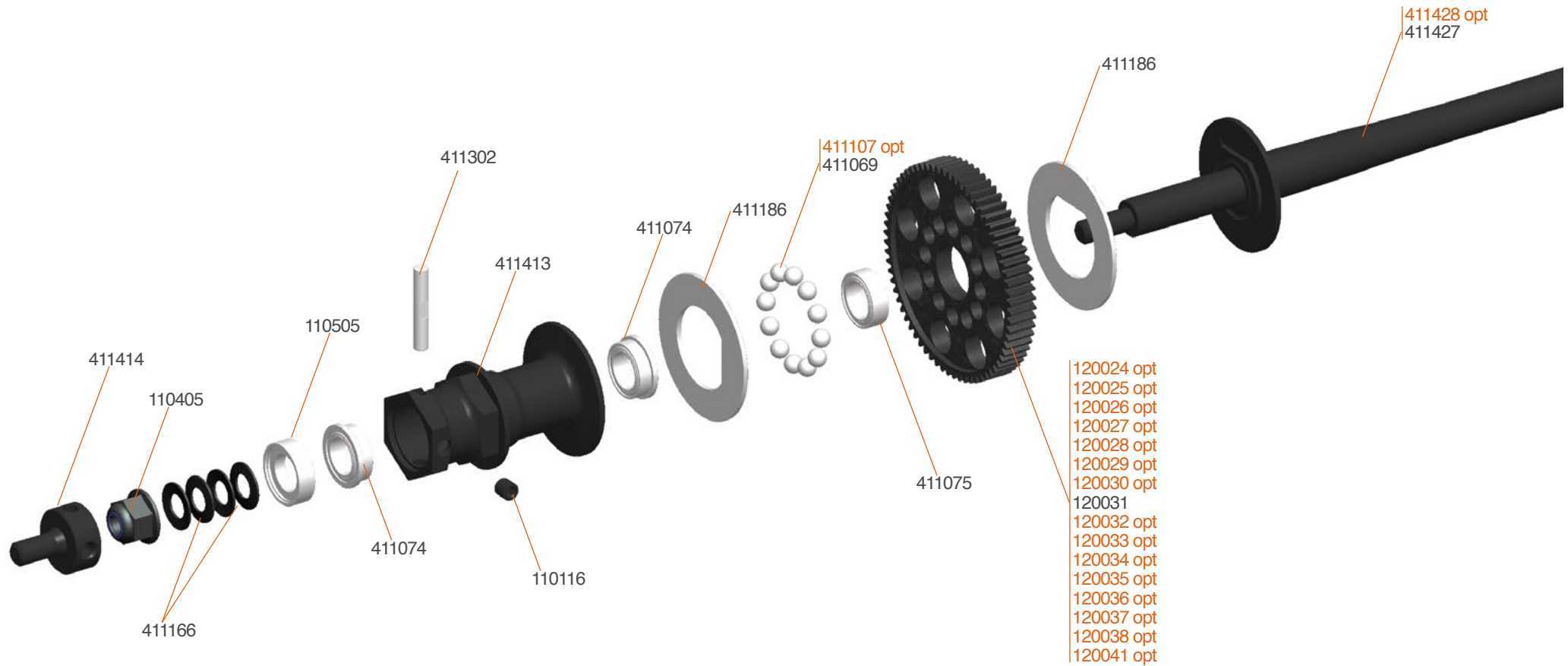

120024 Spur diff gear 64P/86T
 120025 Spur diff gear 64P/90T
 120026 Spur diff gear 64P/94T
 120027 Spur diff gear 64P/98T
 120028 Spur diff gear 64P/102T

120029 Spur diff gear 64P/106T
 120030 Spur diff gear 64P/110T
 120032 Spur diff gear 48P/72T
 120033 Spur diff gear 48P/74T
 120034 Spur diff gear 48P/76T

120035 Spur diff gear 48P/80T
 120036 Spur diff gear 48P/84T
 120037 Spur diff gear 48P/88T
 120038 Spur diff gear 64P/82T
 120041 Spur diff gear 64P/80T

411107 Diff balls. 1/8 ceramic (12)
 411428 Rear axle carbon F110 SF4



411430 Shock set F110 SF4

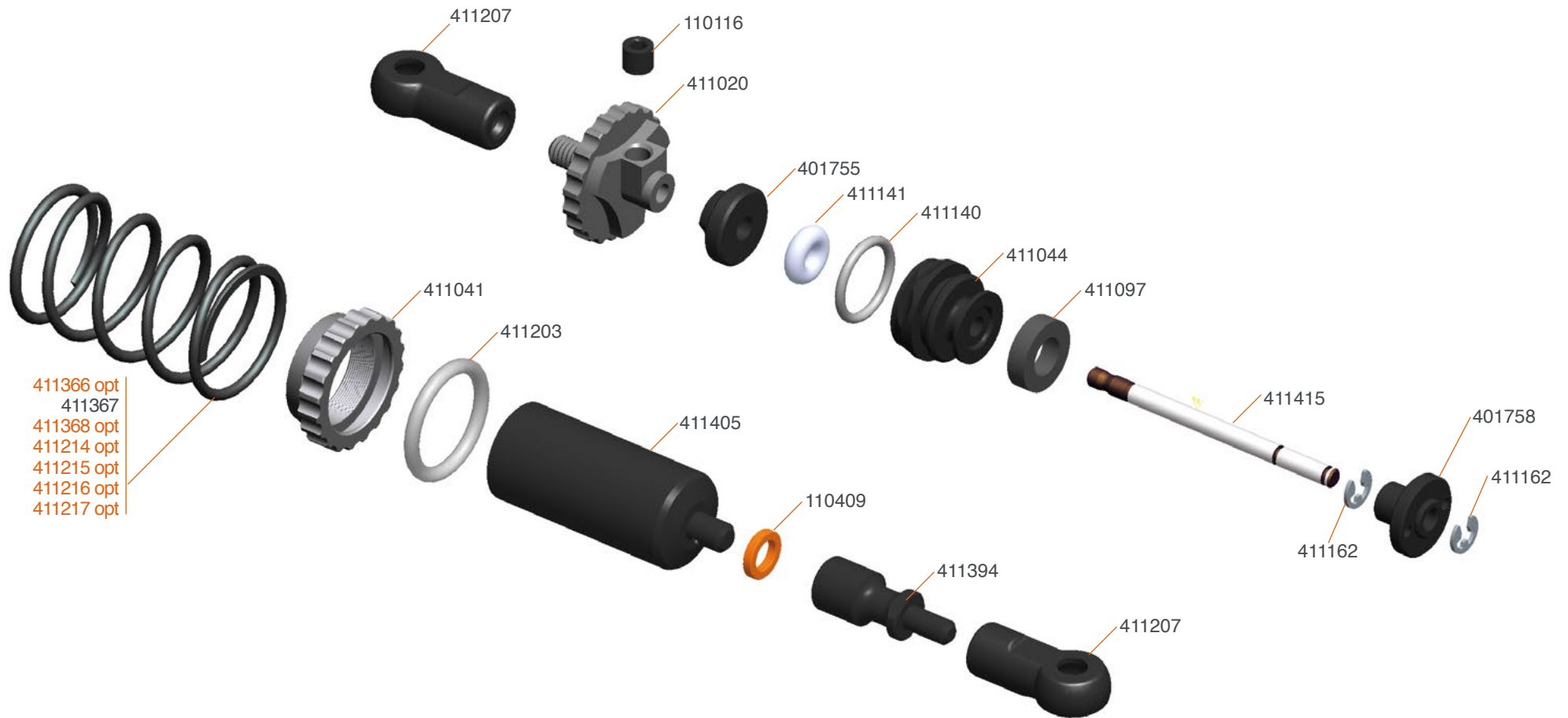

- 411366 Center spring 6.5lbs
- 411368 Center spring 10 lbs
- 411214 Center spring 12lbs S120L
- 411215 Center spring 14lbs S120L

- 411216 Center spring 16lbs S120L
- 411217 Center spring 18lbs S120L

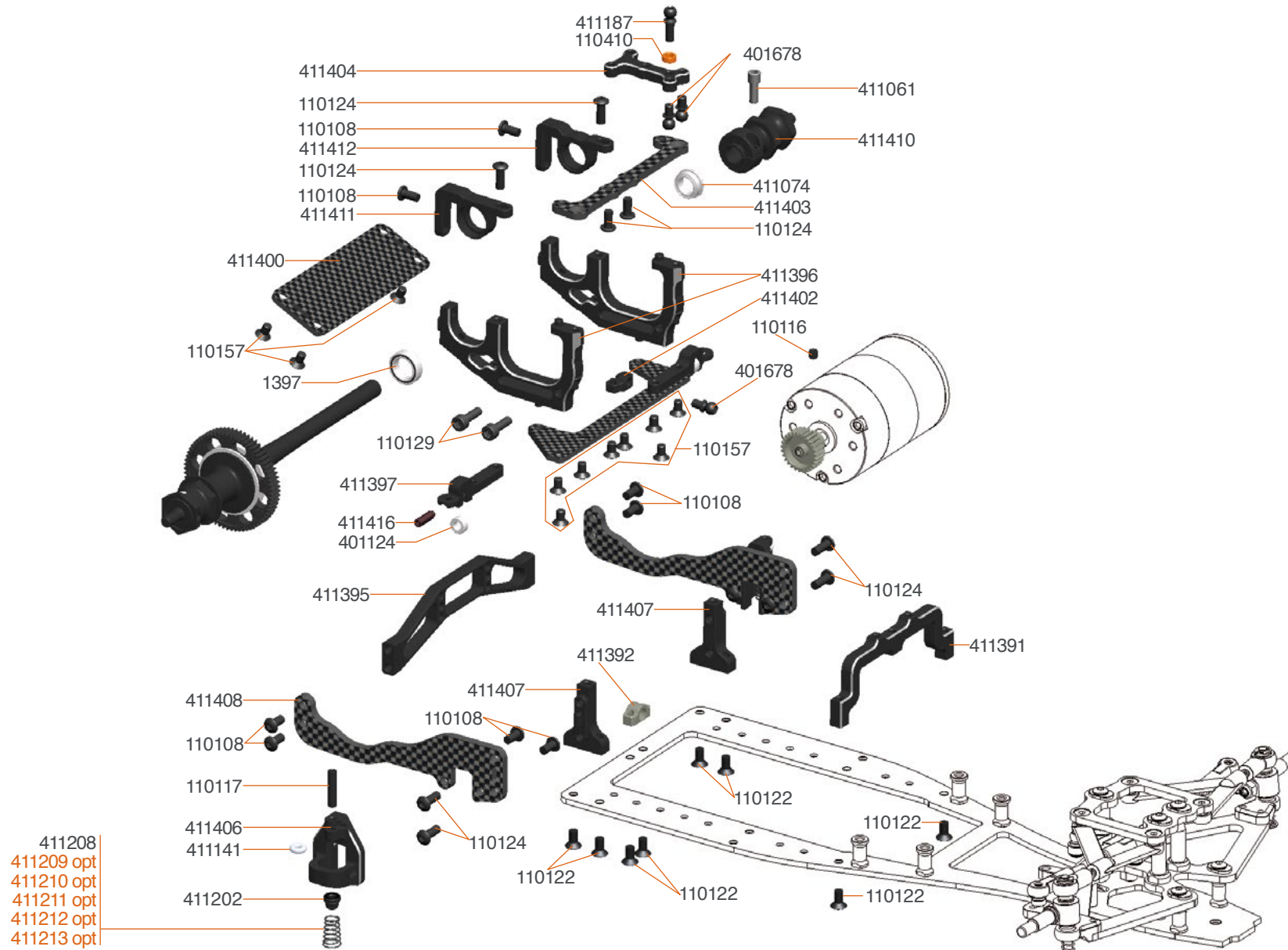

- 411209 Side spring 5,0lbs S120L (2)
- 411210 Side spring 5,5lbs S120L (2)
- 411211 Side spring 6,0lbs S120L (2)
- 411212 Side spring 6,5lbs S120L (2)

- 411213 Side spring 7,0lbs S120L (2)



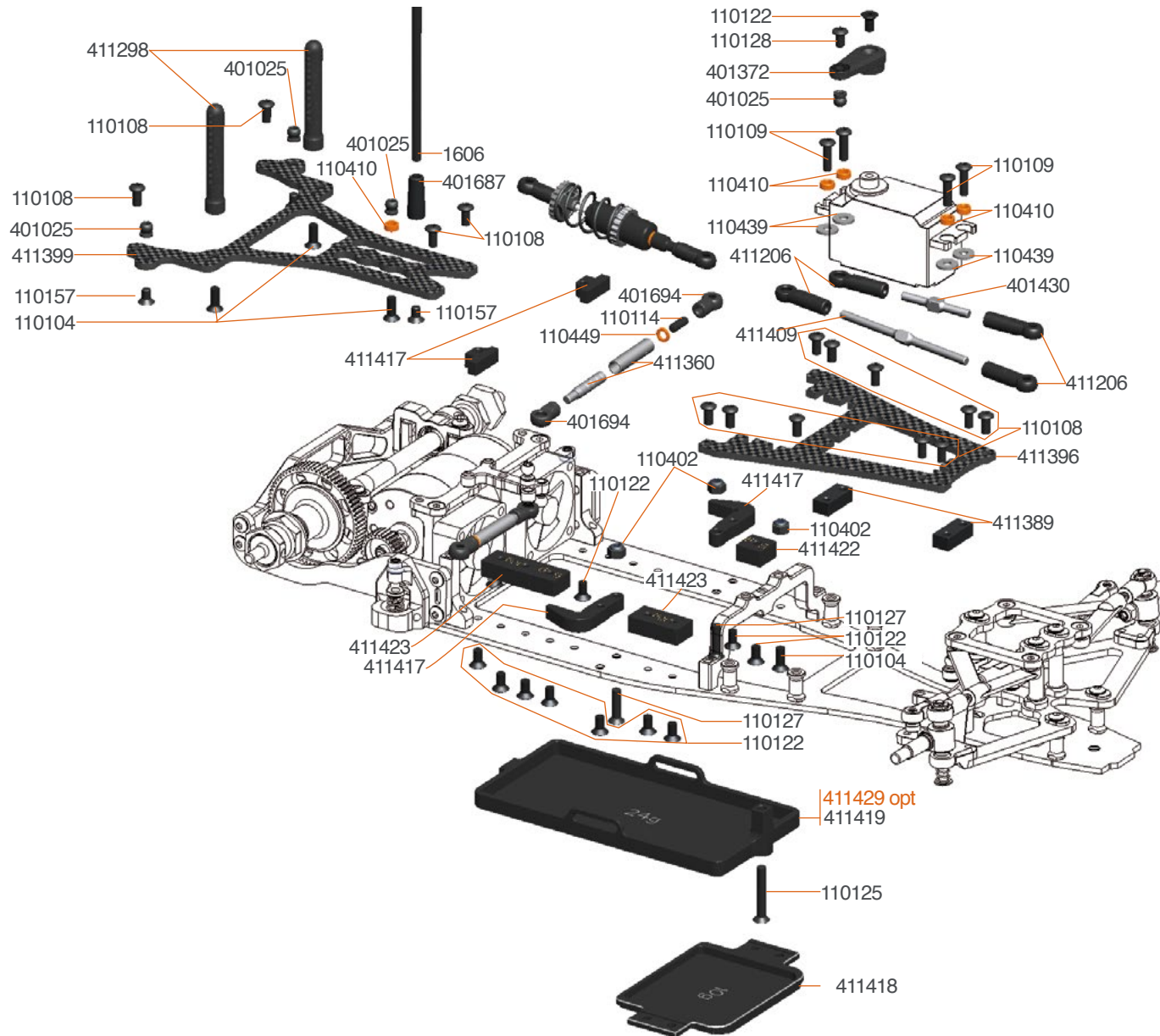

- 411429 Battery holder brass F110 SF4
- 411420 Weight 25gr front low F110 SF4
- 411421 Weight 15gr front up F110 SF4

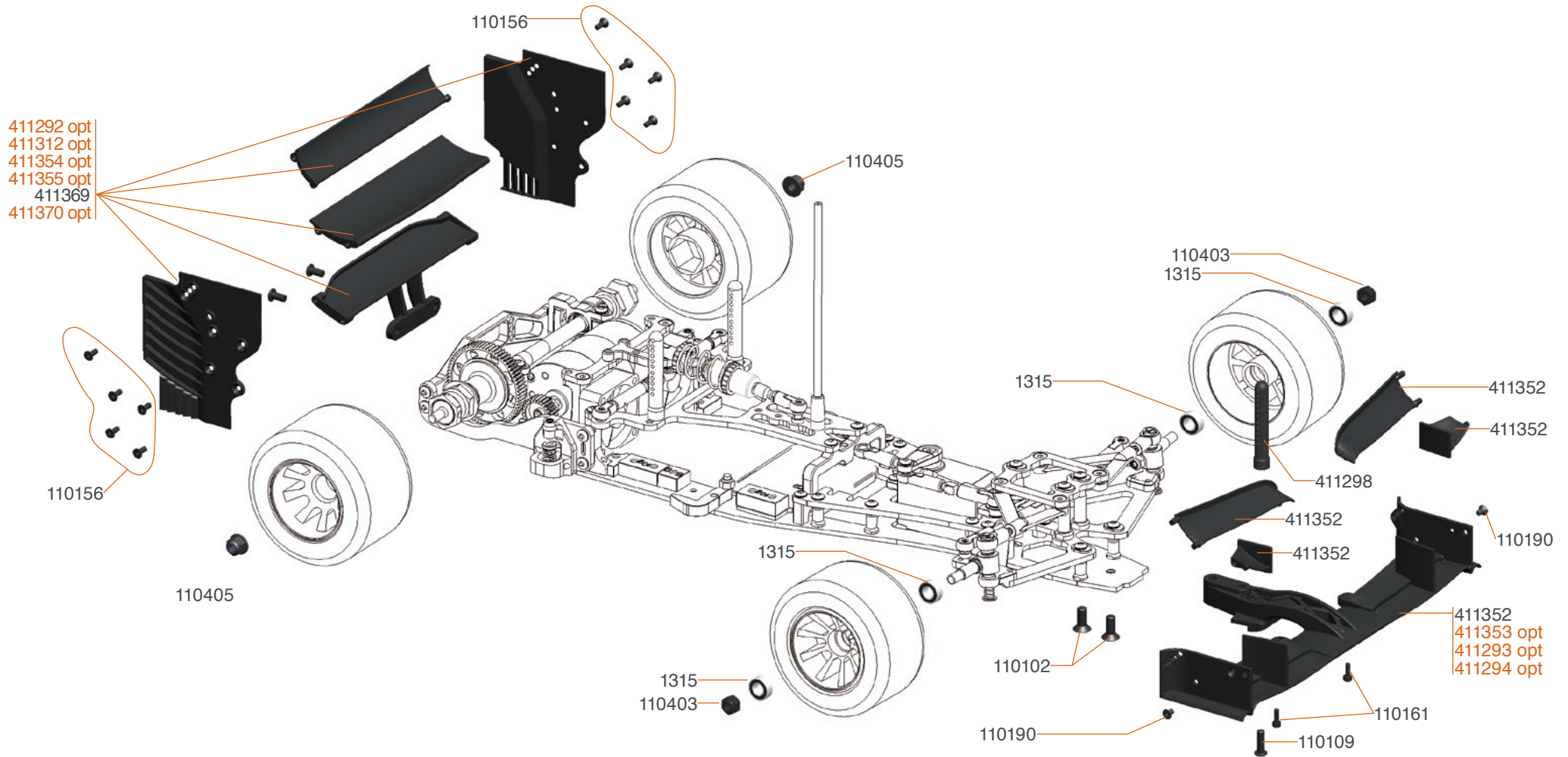

411292 Rear wing F110 black H DF
 411312 Rear wing F110 white H DF
 411354 Rear wing F110 black L DF
 411355 Rear wing F110 white L DF

411370 Rear wing F110 white M DF
 411293 Front bumper F110
 411294 Front wing F110 (big+small)
 411353 Wing front white F110 SF2



TEAM SERPENT NETWORK

F110 SF4 SPARE PARTS www.serpent.com/410067/spares/

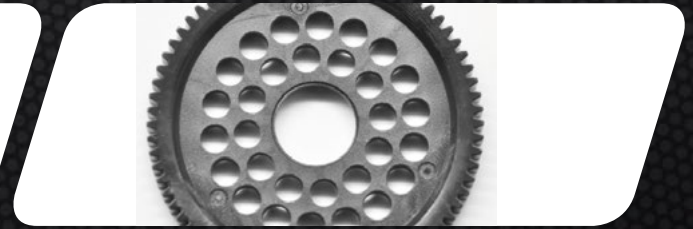

F110 SF4 OPTIONALS PARTS www.serpent.com/410067/Optionals/

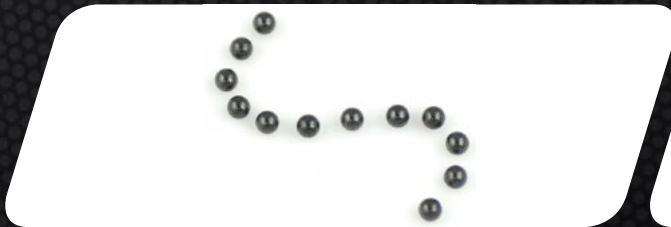

SERPENT TOOLS www.serpent.com/product/Tools/



SERPENT MERCHANDISING www.serpent.com/product/Merchandising/



SERPENT WEBSITE AND BLOG

www.serpent.com
www.teamserpent.com
www.dragon-rc.com

SERPENT PROMO PAGES <http://promo.serpent.com>

SERPENT FACEBOOK GROUPS <http://promo.serpent.com/indexfb.htm>

SERPENT ADVANCED MANUALS <http://promo.serpent.com/sam/>

SERPENT SOCIAL MEDIA



www.facebook.com/SerpentMRC



www.youtube.com/user/SerpentMRC



www.twitter.com/SerpentMRC



www.plus.google.com/+SerpentModelcars/posts



www.weibo.com/teamserpent

F110

1/10 scale electric powered

SF4

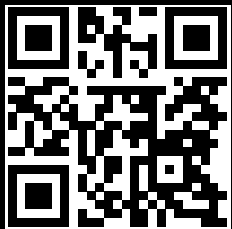

#78384-1 Manual F110 SF4

SERPENT