



INSTRUCTION MANUAL
& REFERENCE GUIDE



INTRODUCTION

Serpent created a highly competitive electric 1/10th scale F1 car with the F110, which like all our previous cars, has been designed to win straight from the box.

Featuring a number of truly innovative features such as a link-type rear support, which combines with the alu tube and a central shock absorber, to control the movement and grip of the rear end. With top quality materials throughout, the F110 should see you in the winners circle in no time. In fact everything associated with this car is of the highest quality, from the packaging and supplied manuals, right through to the product and race support.

INSTRUCTIONS

Serpent's long tradition of excellence extends to the instruction manuals, and this instruction manual is no exception. The easy-to-follow layout is richly illustrated with 3D-rendered full-color images to make your building experience quick and easy. Following the instructions will result in a well-built, high-performance race-car that will soon be able to unleash its full potential at the racetrack.

INSTRUCTIONS, HOW TO USE

The kit includes bags, with bag numbers, which refer to the same step in the manual. Open only the indicated bag(s) per step and finish that part of the assembly. Remaining parts will be needed later on in the assembly process.

SETUP

In certain assembly steps you need to make basic adjustments, which will give you a good initial setup for your Serpent F110. Fine-tuning the initial setup is an essential part of building a high-performance racecar like your F110.

EXPLODED VIEWS AND PARTS LIST

The exploded views and parts lists for the Serpent F110 are presented in the Reference Guide section in the back of this manual. The exploded views show all the parts of a particular assembly step along with the Serpent part number. The parts lists indicate the part number and name of each part for easy reference when ordering.

CUSTOMER SERVICE

Serpent has made a strong effort to make this manual as complete and clear as possible. Additional info may be published in our website: www.serpent.com or you may ask your dealer or the Serpent distributor for advice, or email Serpent direct: info@serpent.com



The Serpent Facebook, Twitter and Youtube pages give additional means of support and communications.

SAFETY

Read and take note of the 'Read this First' section before proceeding to assemble the car-kit. This car-kit is intended for persons aged 16 or older.

Read this first!

- This is a highly technical hobby product, intended to be used in a safe racing environment. This car is capable of speeds in excess of 80 km/h or 50mph. Please follow these guidelines when building and operating this model.
- Parental guidance is required when the builder/user of this car is under 16.
- Follow the building instructions. If in doubt, contact your dealer or importer.
- Be sure to use the proper tools when assembling the car. Always exercise caution when using electric tools, knives and other sharp objects.
- Be careful when using liquids like lubrication oil, fuel or glue. Do not swallow.
- Follow the manufacturer's instruction in case you experience irritation after using the product.
- Be careful when operating the car. Stay away from any rotating parts such as wheels, gears and transmission. Stay away from motor, engine and exhaust pipe system or speedo during and immediately after use, as these parts may be very hot. We advise to use protective hand gloves.
- Only operate this car in a safe environment, like a special racing track or a closed parking lot. Avoid using this car on public roads, crowded places or near infants.
- Before operating this car, always check the mechanical status of the car. Also check that the transmitter and receiver frequencies correspond and are not used by any other racer at the same time. Check that the batteries of the transmitter and receiver- are fully charged.
- After use, always check all the mechanics of the car. We advise to clean the car immediately after use, and inspect the parts for wear or fractures. Replace when necessary. Do not use water, methanol, thinner or other solvents to clean the car.
- Empty the fuel tank (depending on model) if needed and disconnect the receiver battery.
- Store the car in a dry and heated place to avoid corrosion of metal parts.
- Avoid using this car in wet conditions as the water will cause corrosion on the metal parts and bearings and these parts will cease to function properly. If driven in the wet, ensure that all the electric equipment is waterproofed and after use, that all moving parts are dried immediately.

USING THE MANUAL

Each step contains a variety of numbers, lines, and symbols. The numbers represent the order in which the parts should be assembled. The lines and symbols are described below.

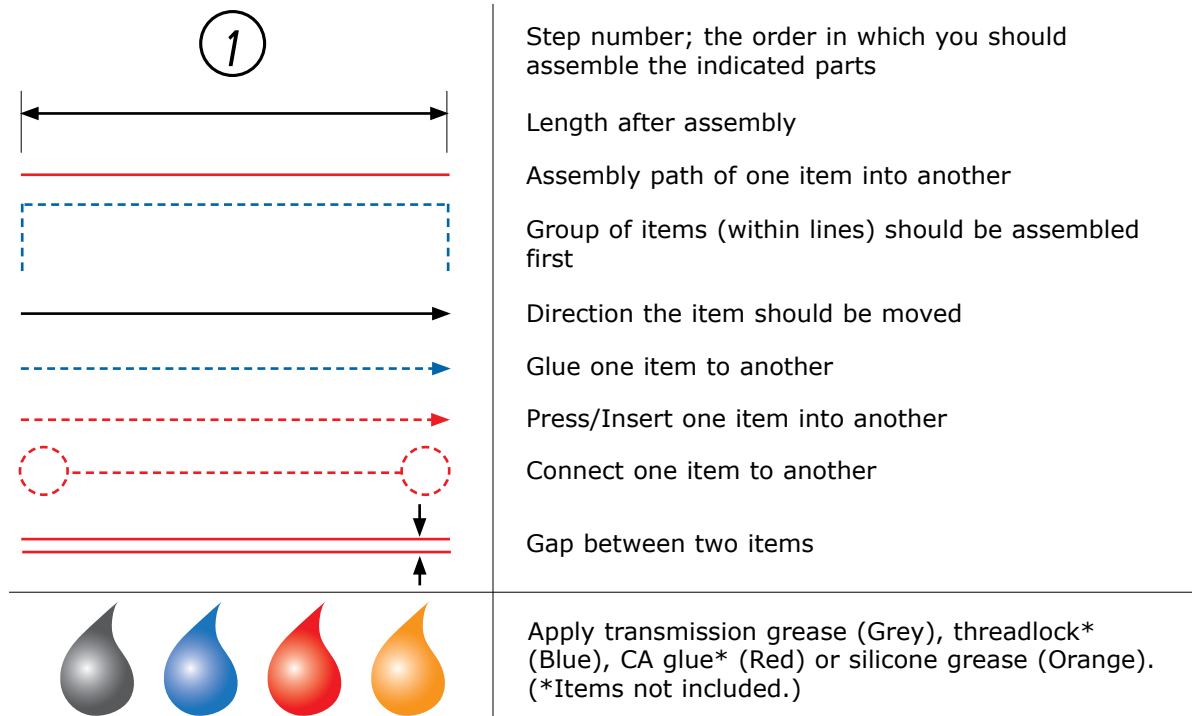

SECTION A: ASSEMBLY INSTRUCTIONS

A

CA Glue

To prevent the risk of the carbon fibre splitting in the event of a crash you should apply CA Glue around the chassis' edge and the power pod plate external and internal edge as shown in red below.

1



KIT

2

Bag 1

Nylock Nut M3 Low Alu

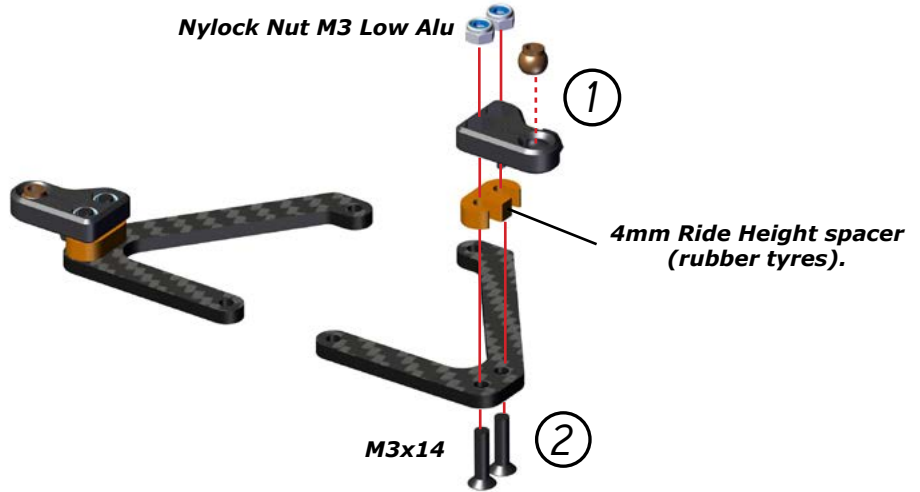

3

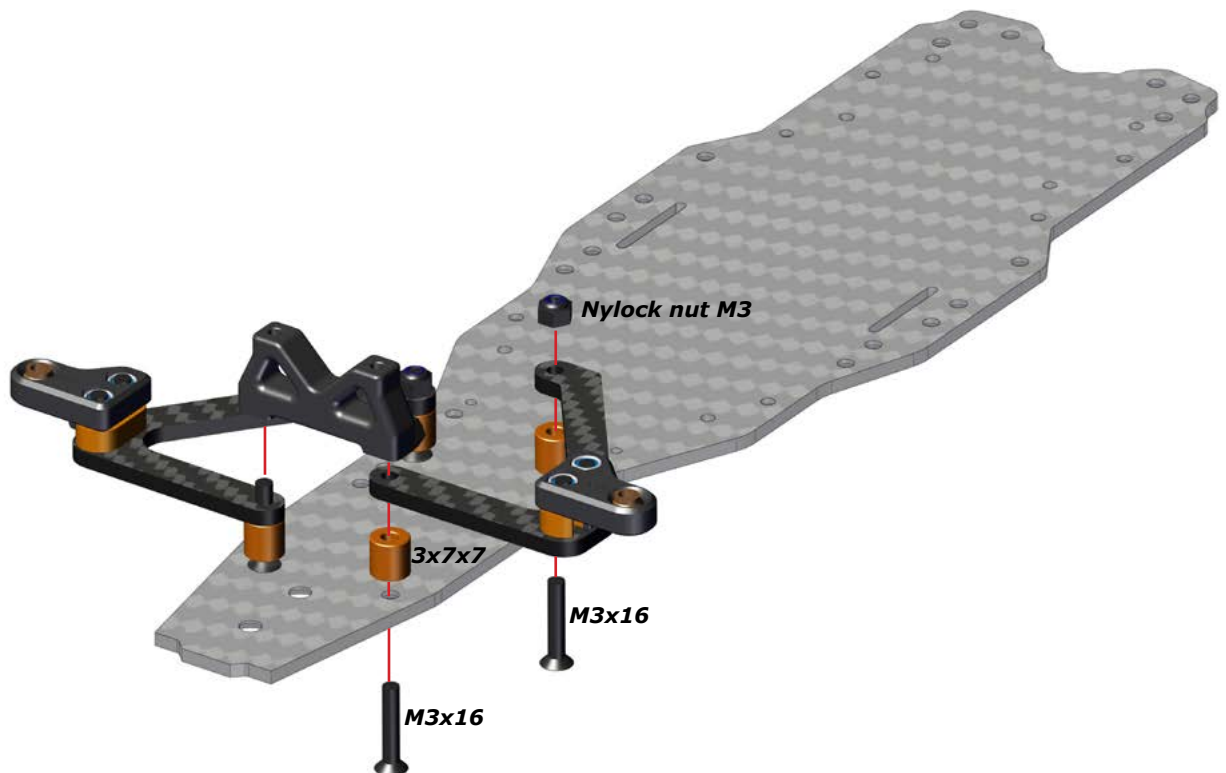

FLIO

Page

4

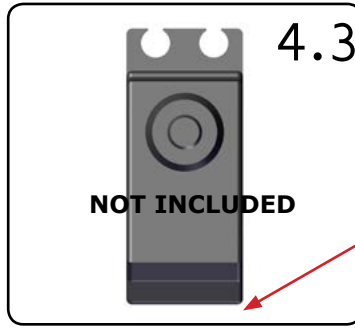
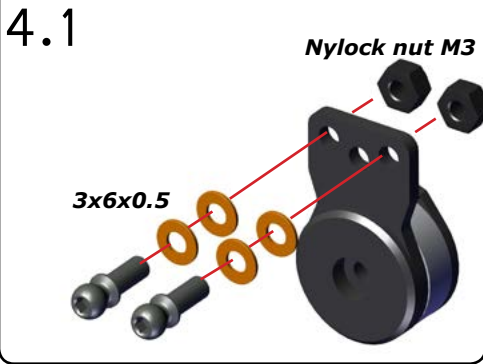

NOTE: It is needed to remove the servo holes of the bottom part of the servo before going onto the step 4.4.



4.4

Use the following servo saver insert with this brand of servos:
 23 - Sanwa / KO / JR
 24 - Hitec
 25 - Futaba (default)

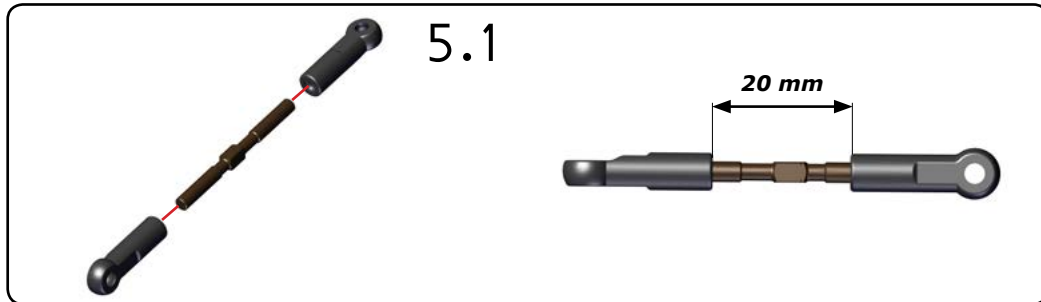
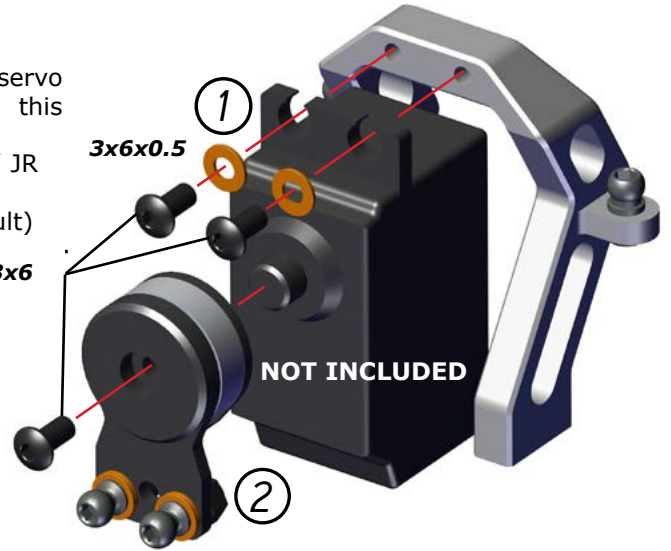

5.2

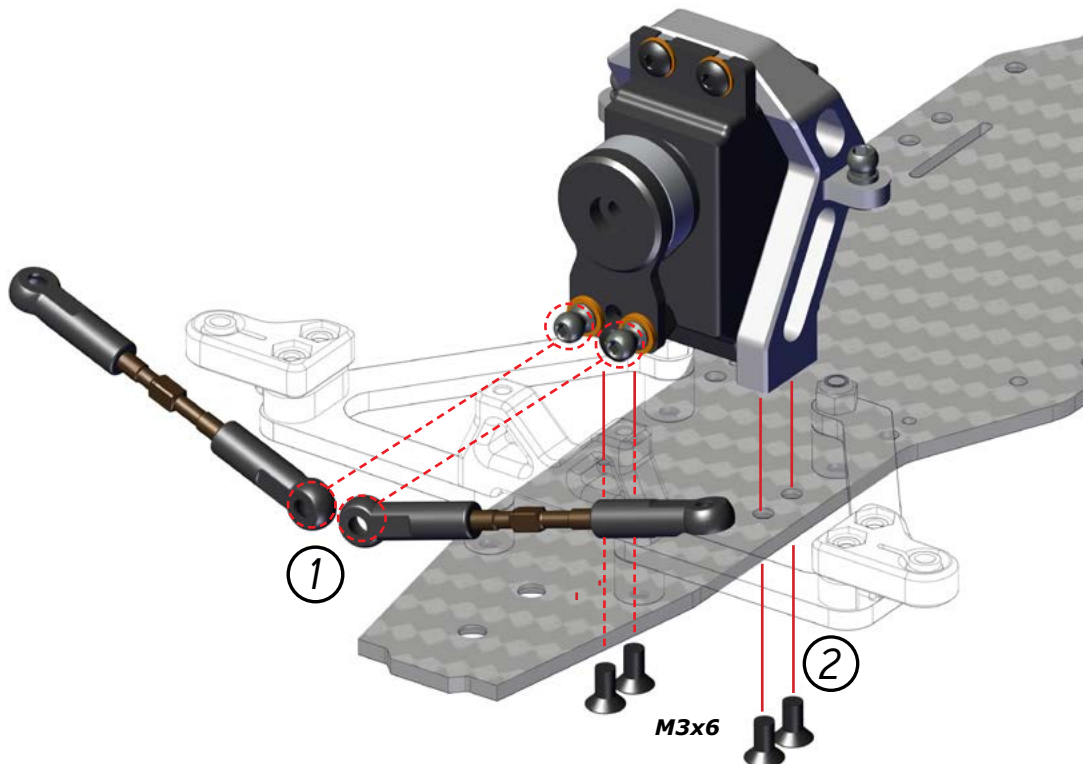

Assemble the pivot-ball in the inner hole of the steeringblock as default setup.

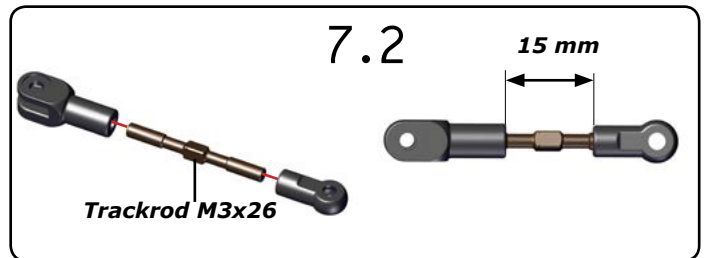
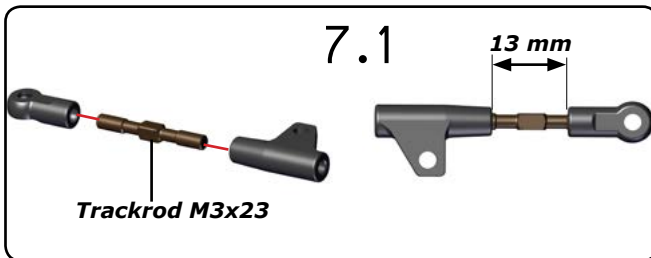
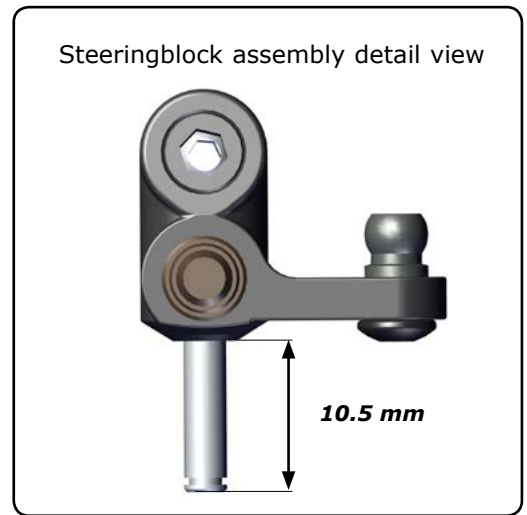
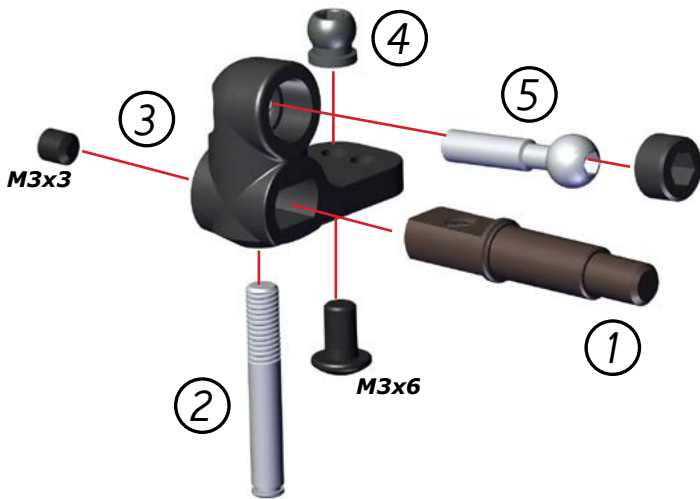

7.3

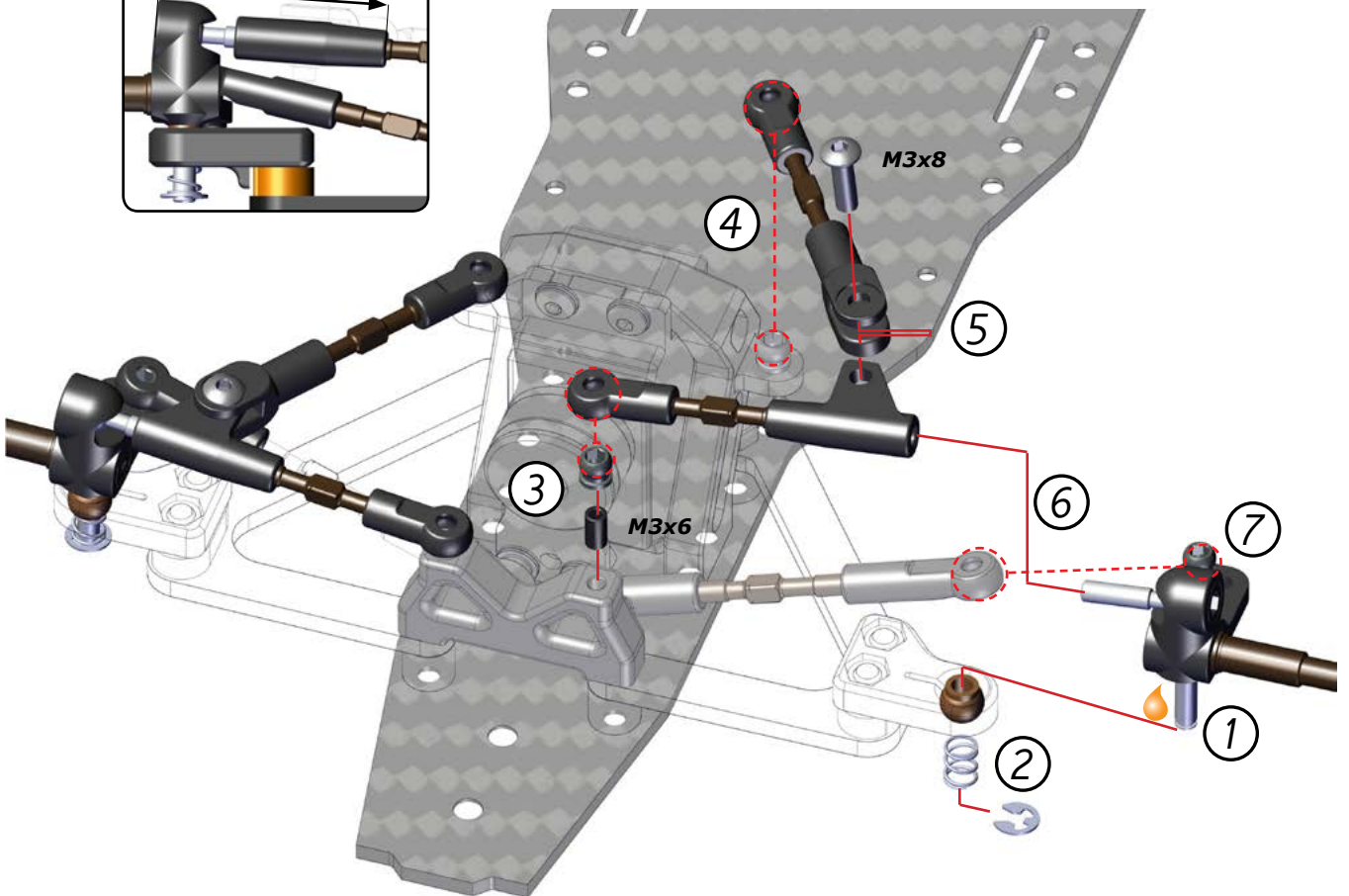
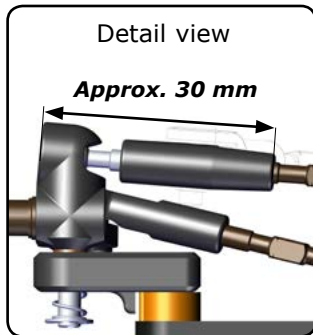

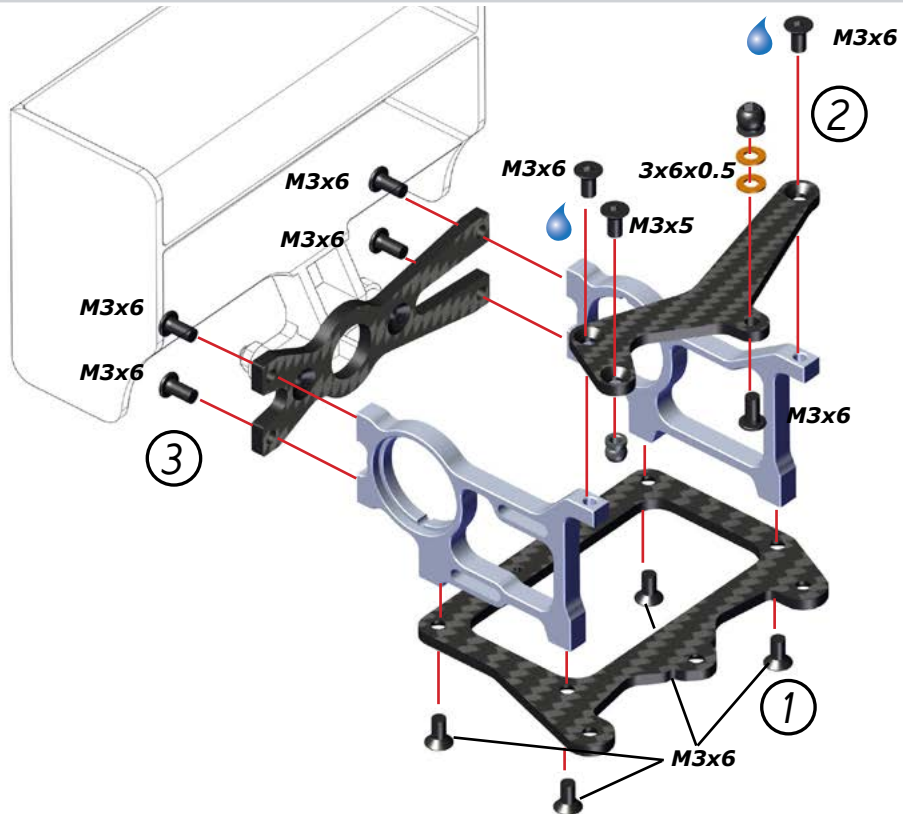
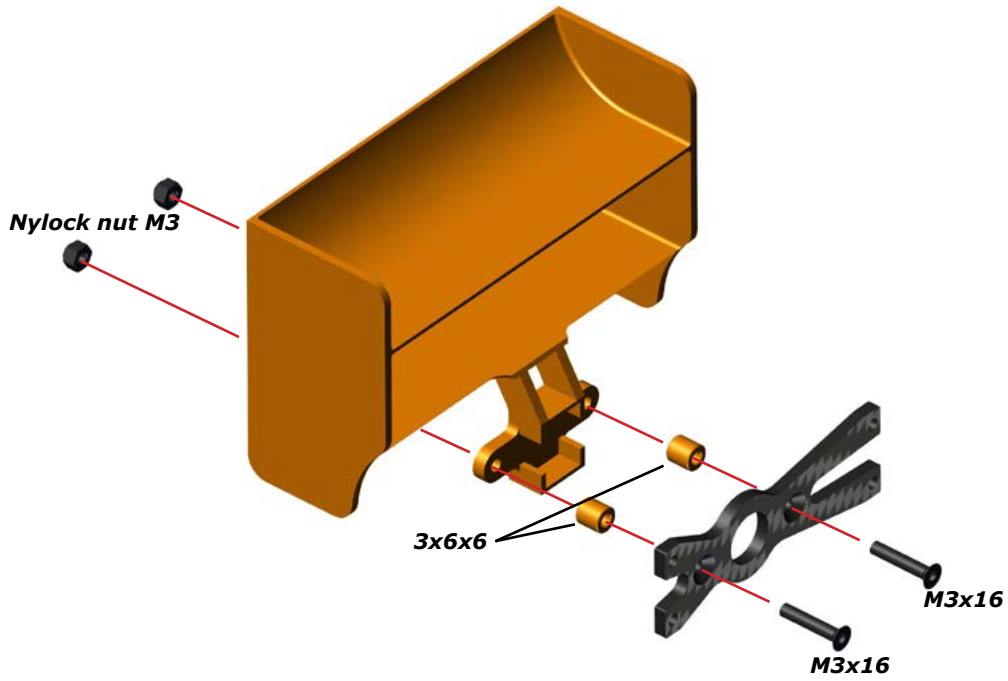
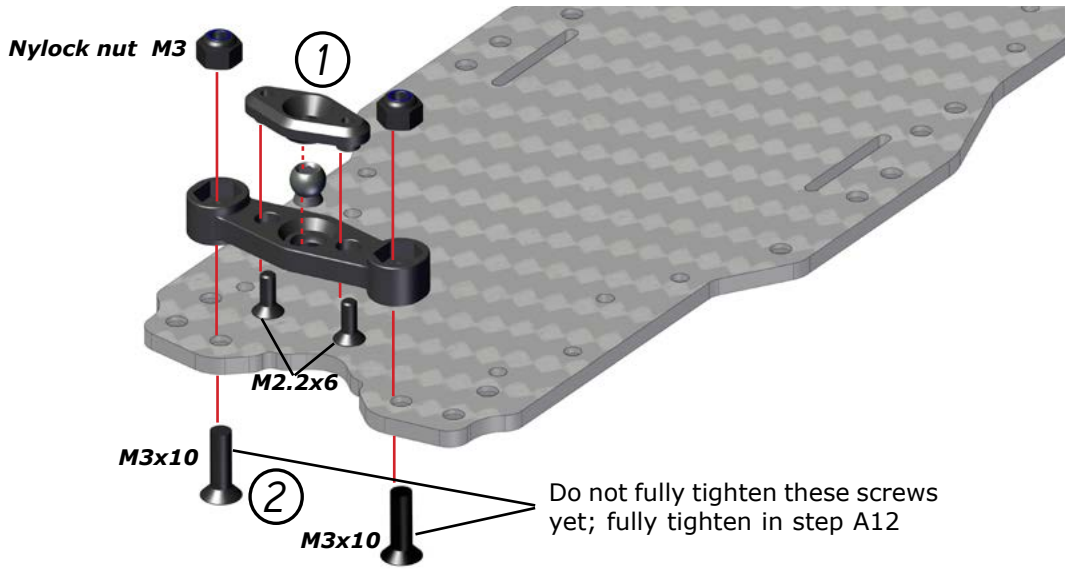

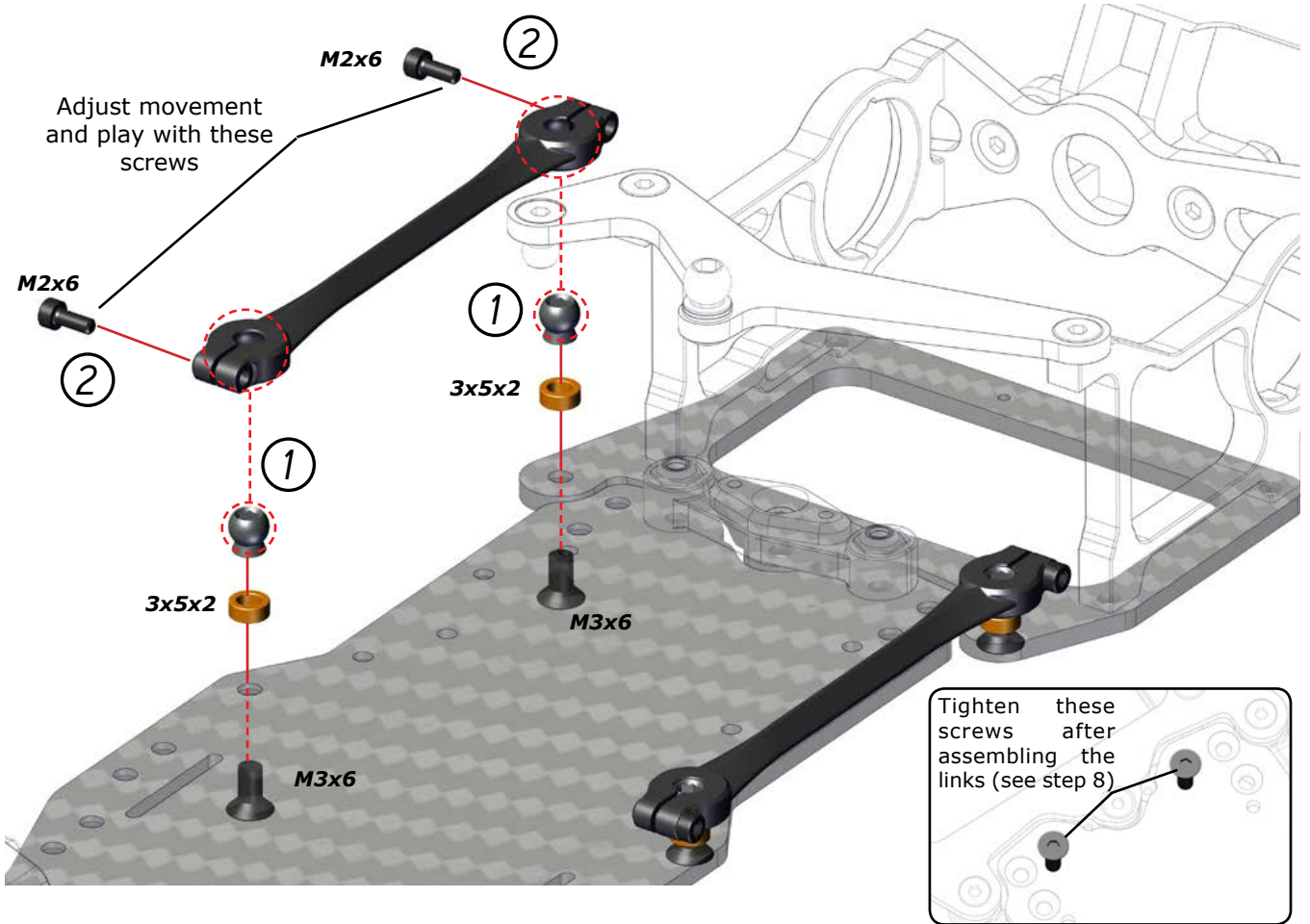
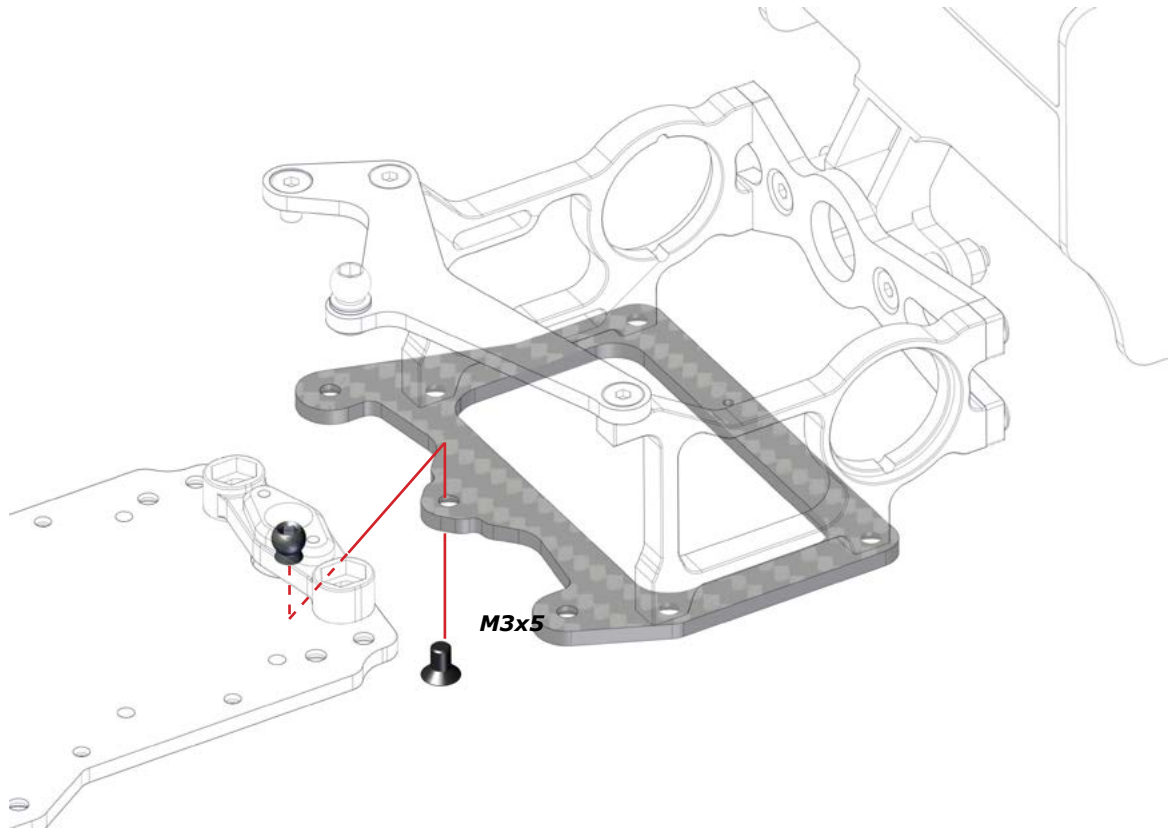

Configuration for 2S Standard Lipo

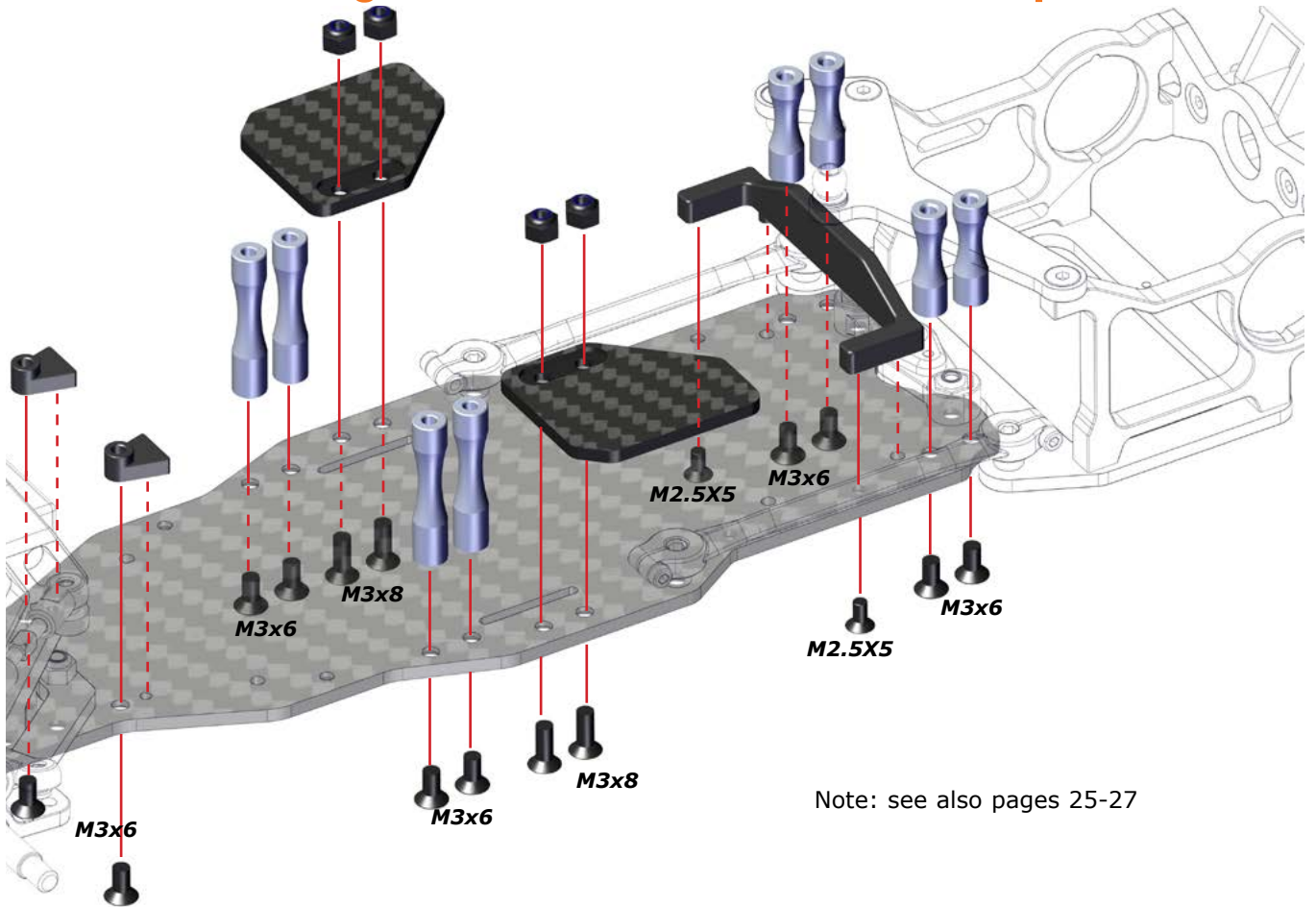

Configuration for 2S Shorty Lipo

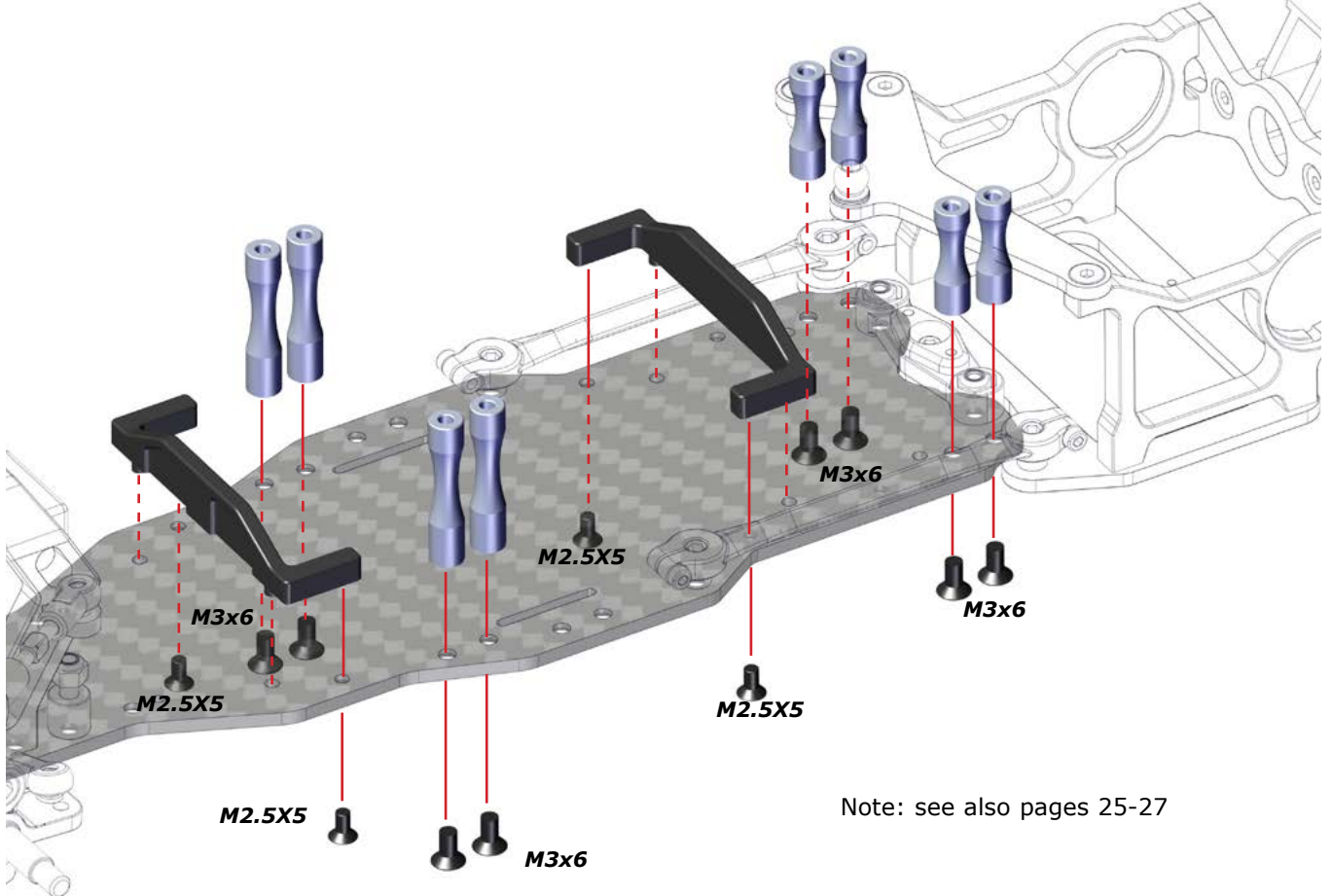

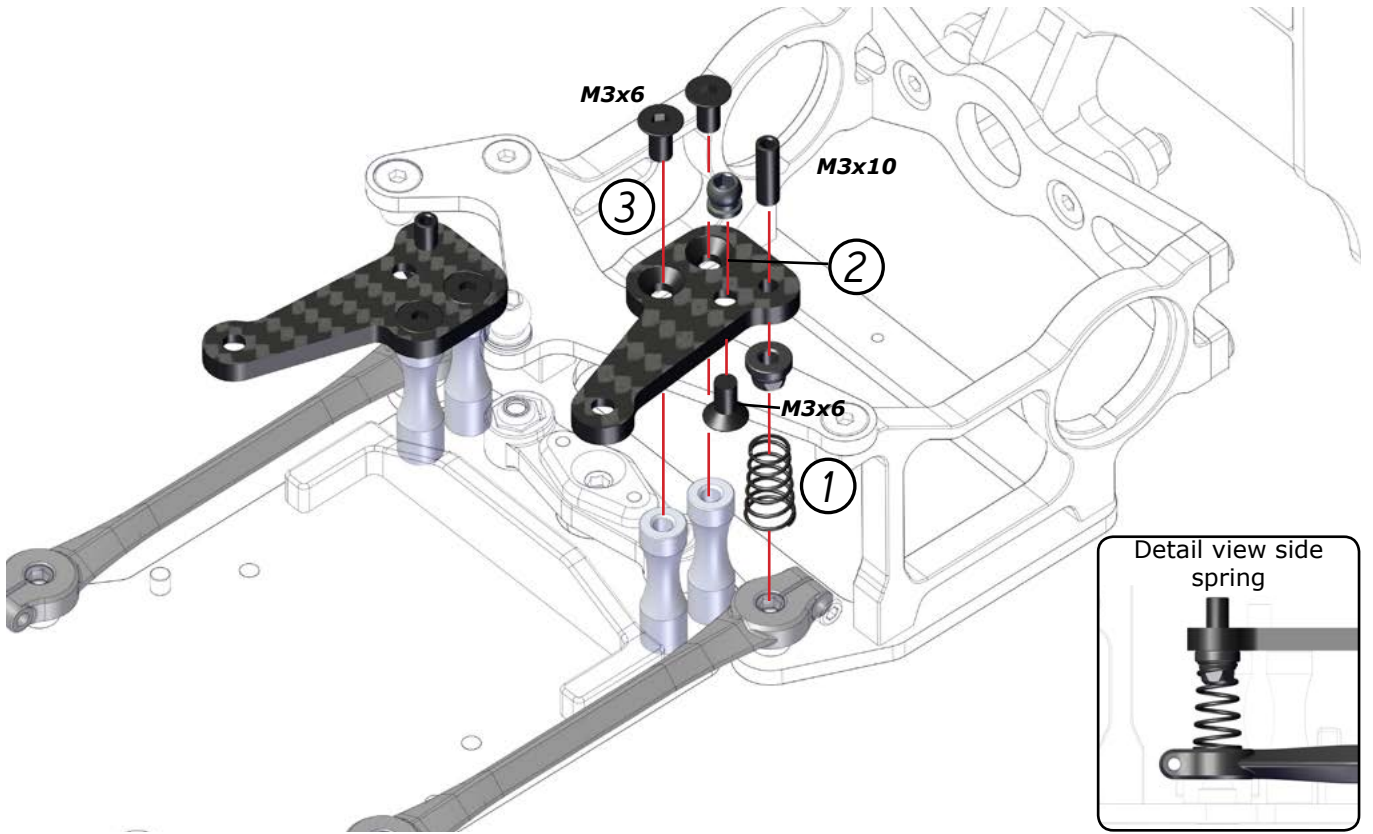

15.1

Fill the tube with heavy silicon oil (15000 cst)

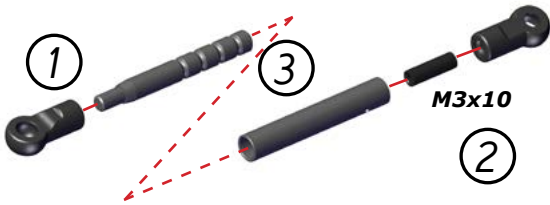

15.2

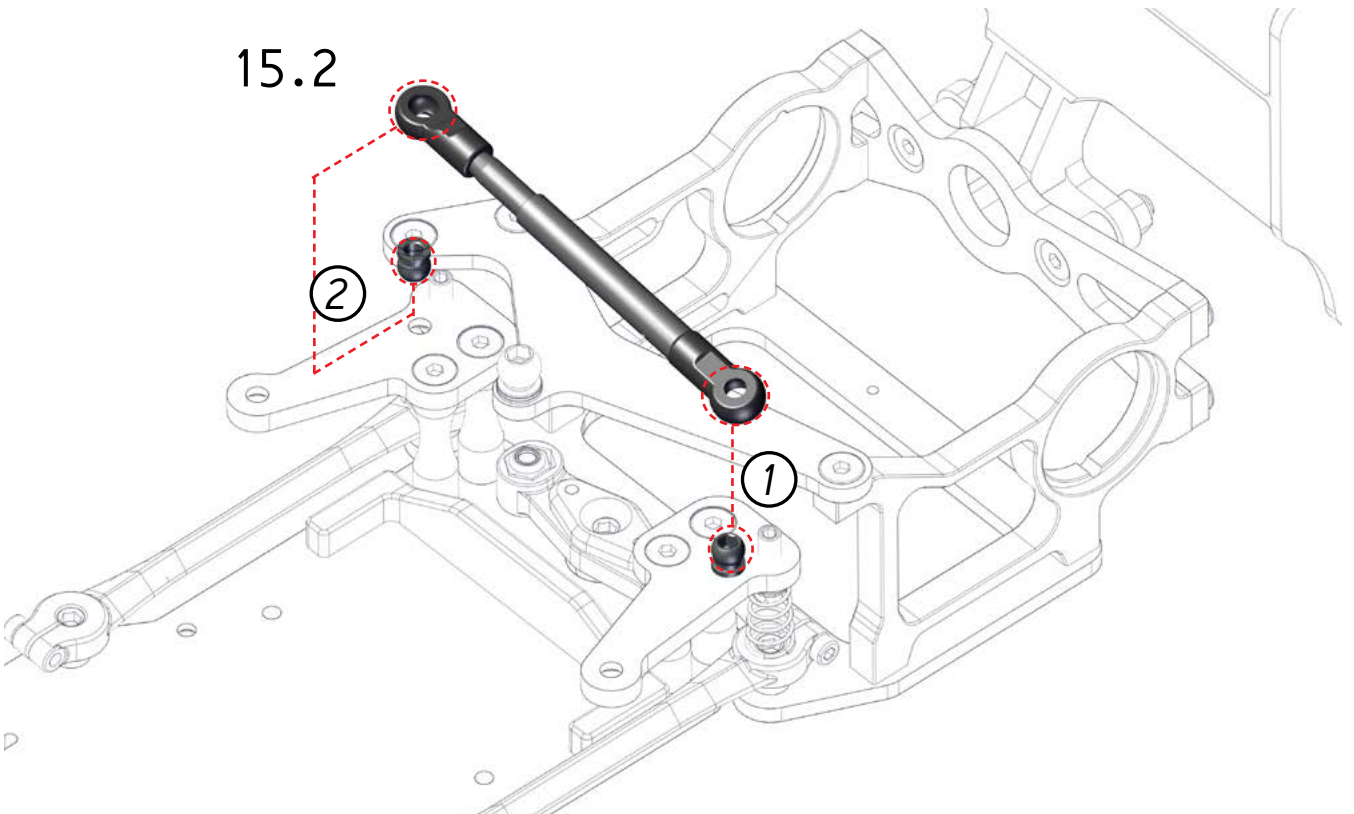

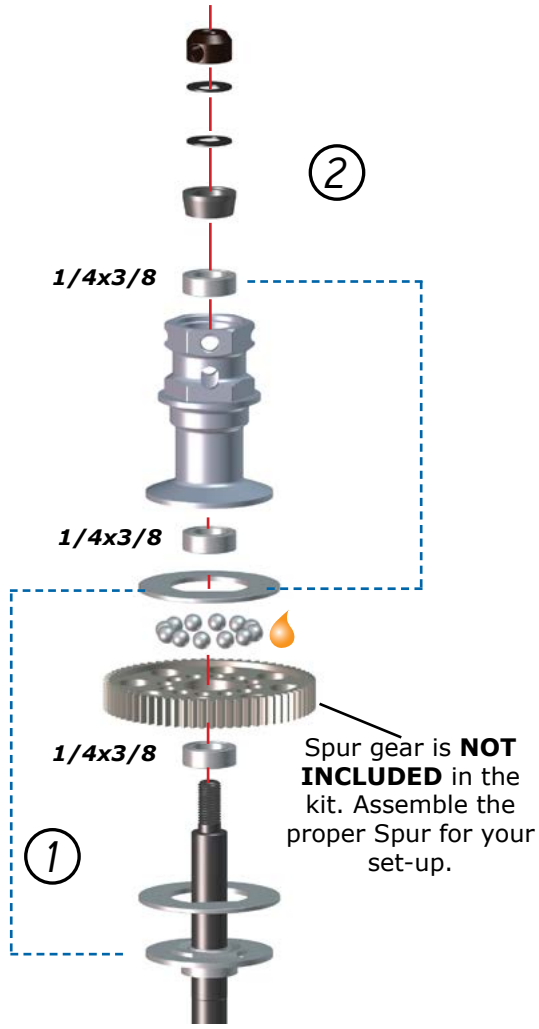

Note Spring washer orientation.



HOW TO ADJUST THE BALL-DIFF: In order to tighten or loosen the ball-diff, you should follow the next two steps:

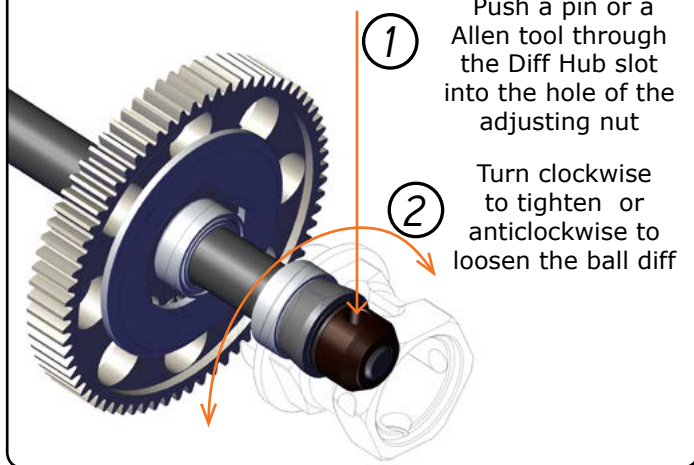

Note insert orientation. Assemble as basic setup for rubber tyres 0/20 insert.

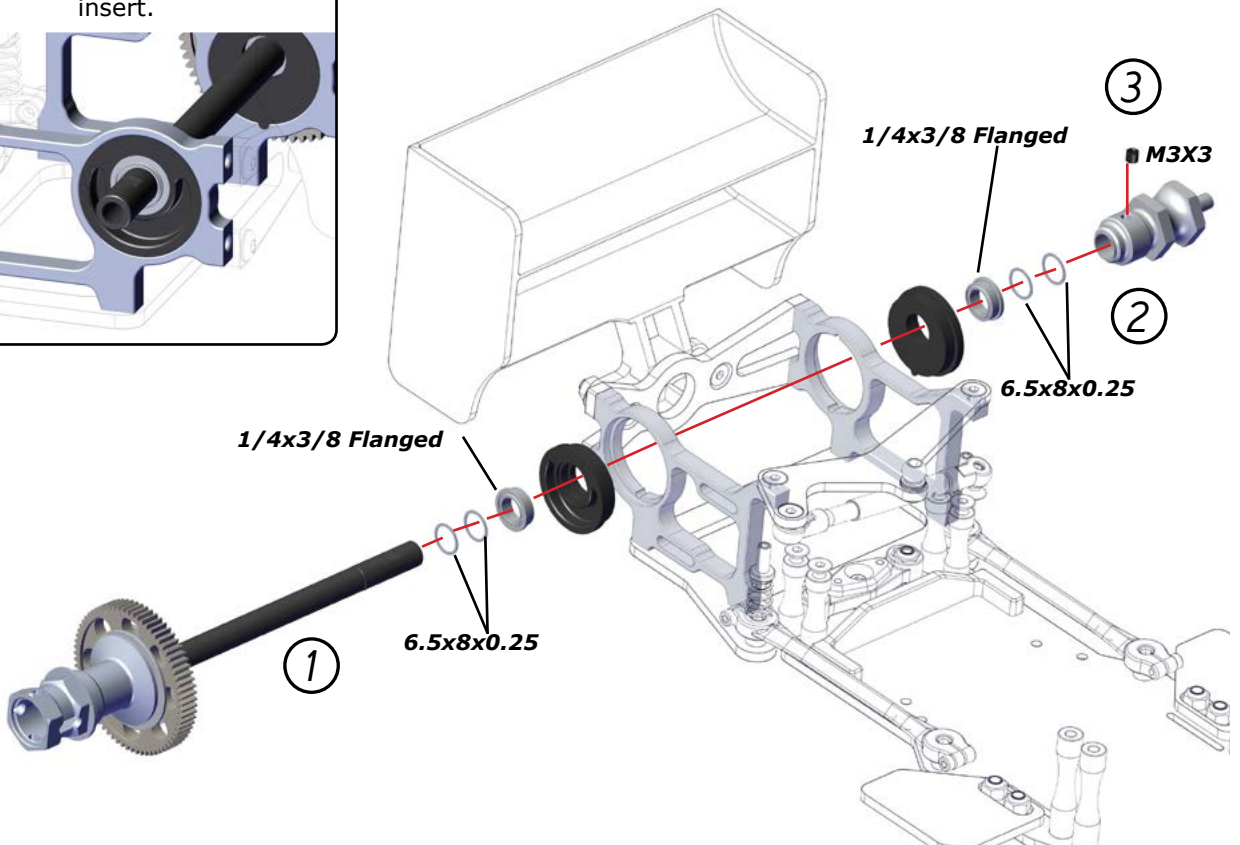
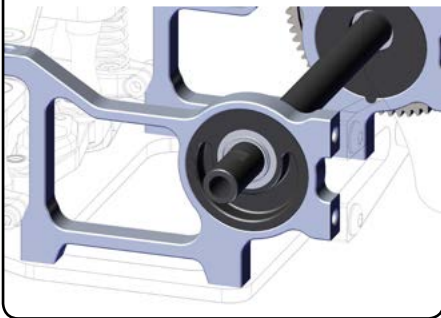

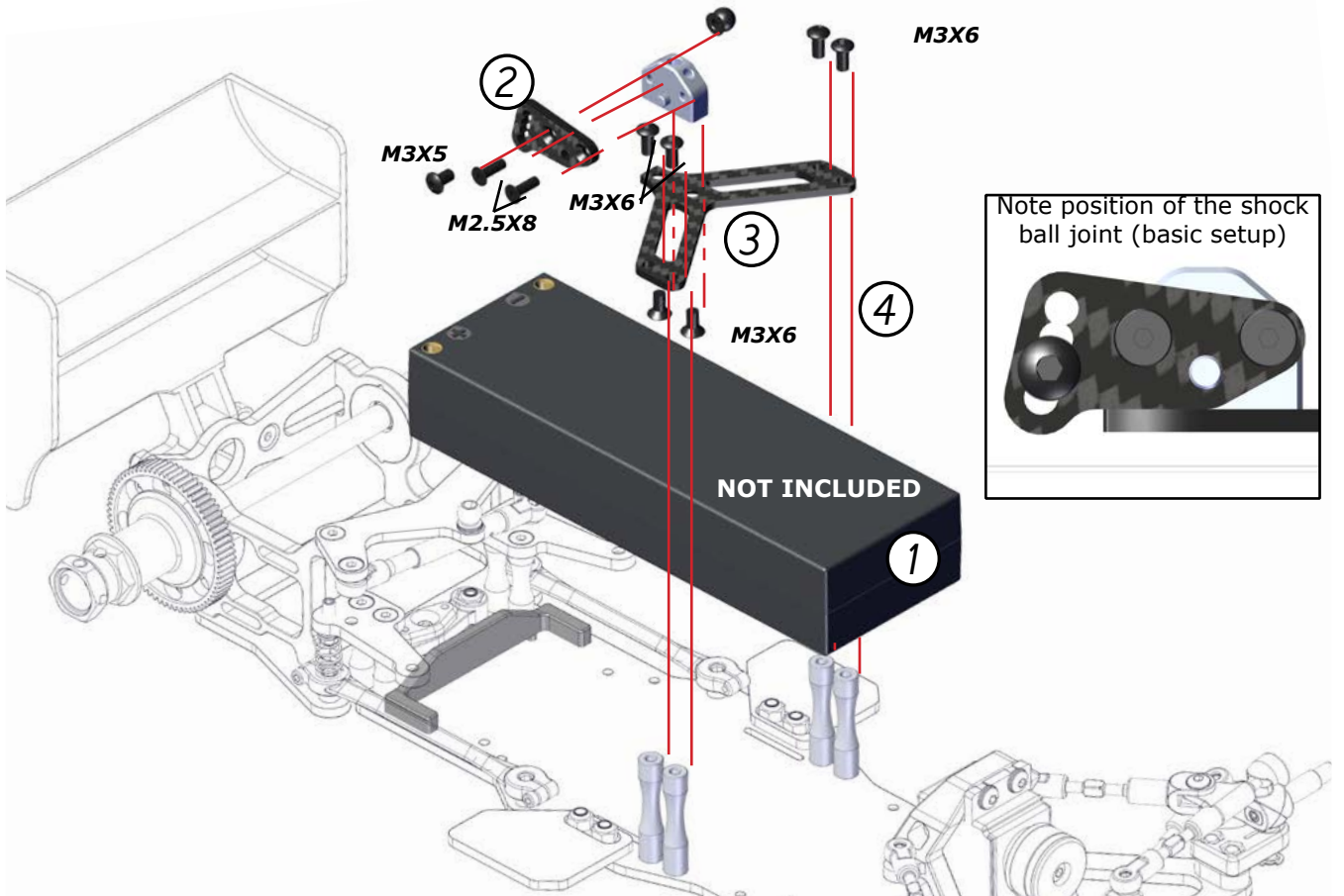

Electronics position with standard 2S Lipo

Tip: Use double sided tape to mount the ESC and RX to the sideplates.

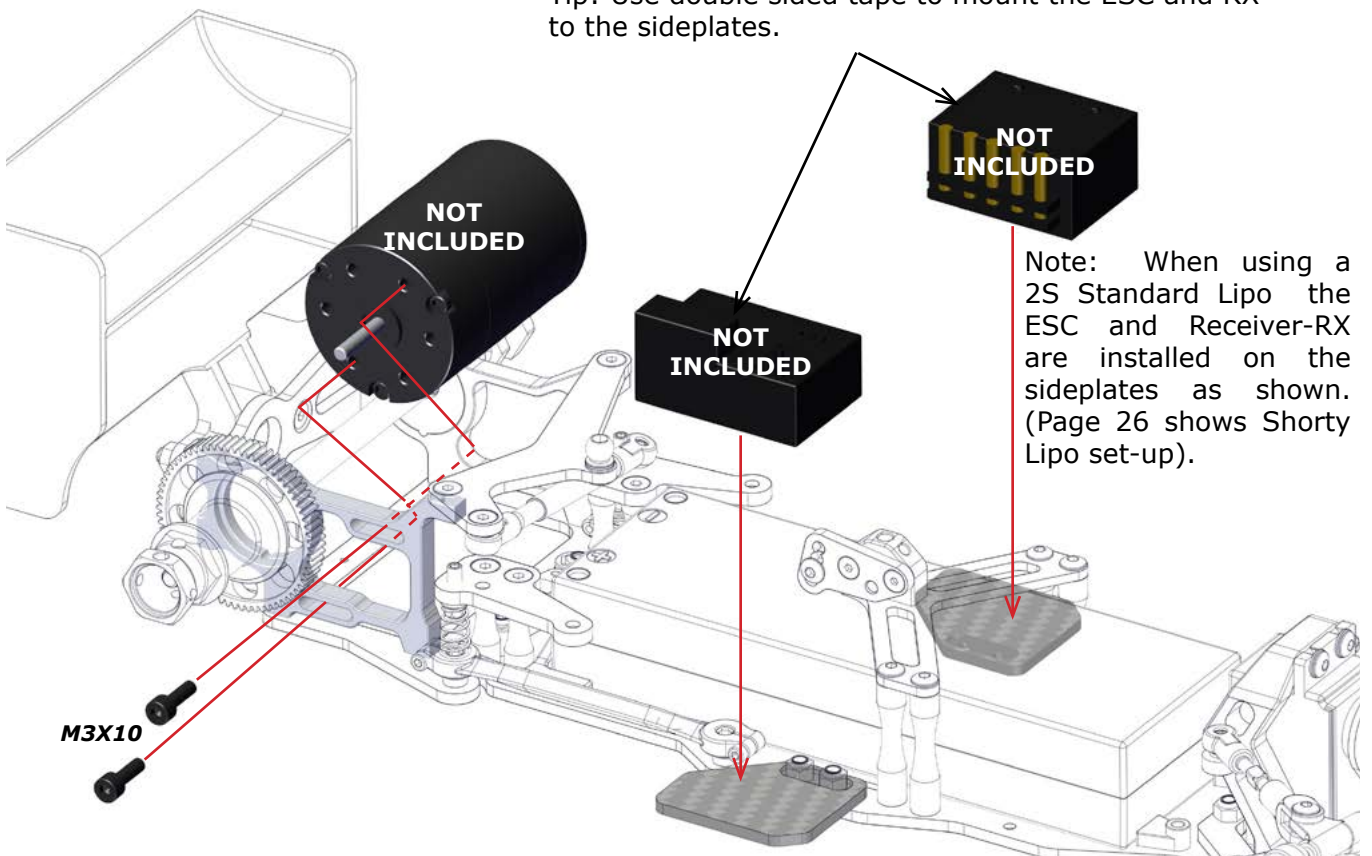

Electronics position with Shorty 2S Lipo

Tip: Use double sided tape to mount the ESC and RX to the chassisplate.

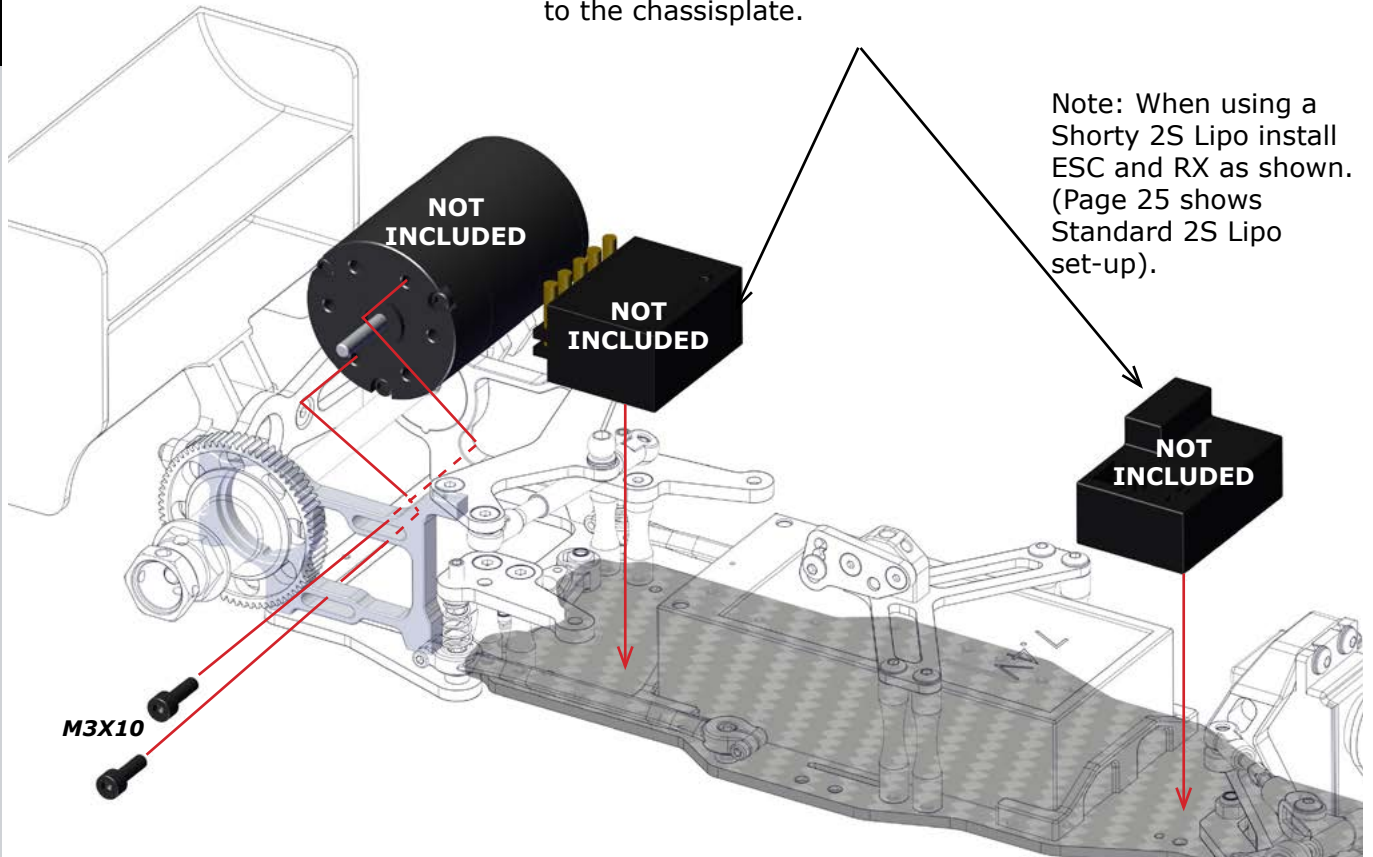

Electronics configuration for using 2S STANDARD Lipo Batteries

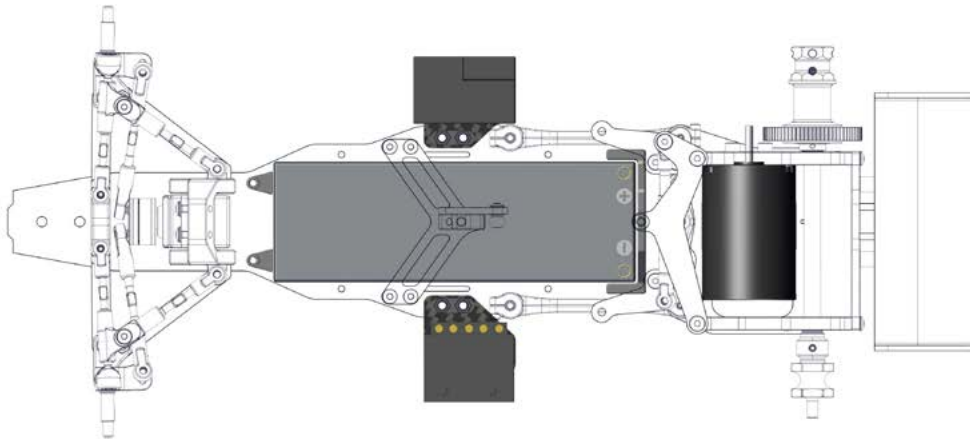

Electronics configuration for using 2S SHORT Lipo Batteries

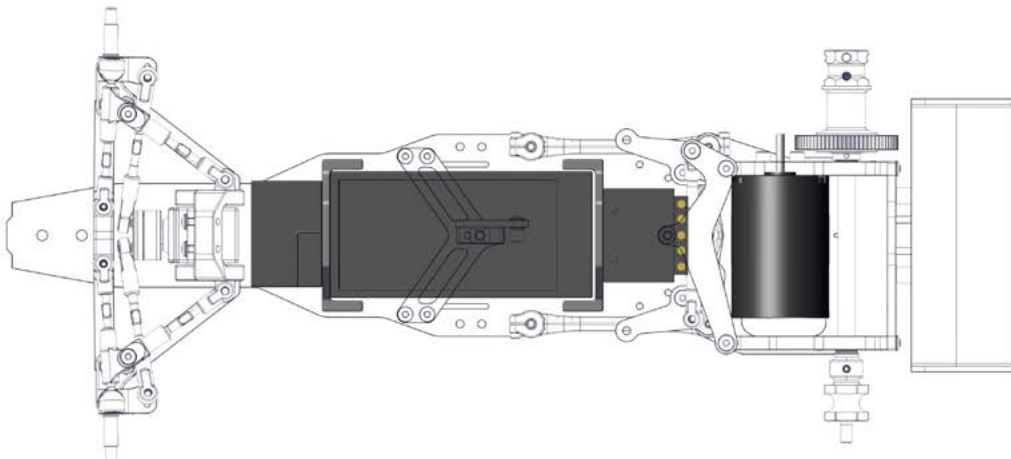

A RCM SHOCK ASSEMBLY

20

Bag
6

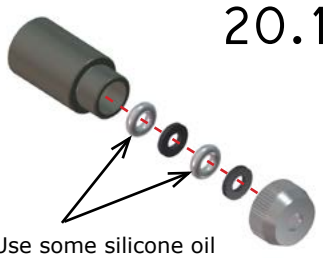

20.1

Use some silicone oil during assembly

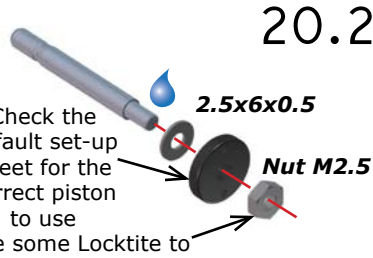

20.2

Check the default set-up sheet for the correct piston to use
Use some Locktite to fix the nut



20.3

Use some silicone oil during assembly



20.4

Insert the o-ring inside the nut

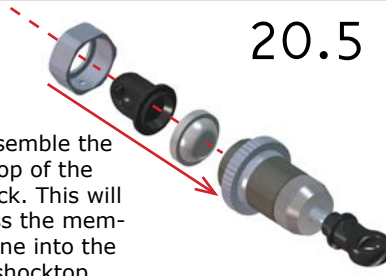

20.5

Assemble the top of the shock. This will press the membrane into the shocktop



20.6

Remove the top of the shock



20.7

Fill the shock body with the supplied shock absorber oil. Slowly move the shockrod up and down to let the airbubbles escape.



20.8

Close the top of the shock



20.9

Measure fully extended

10.5 mm



20.10

Assemble the spring and spring-cup (align correctly) to complete the shock

21

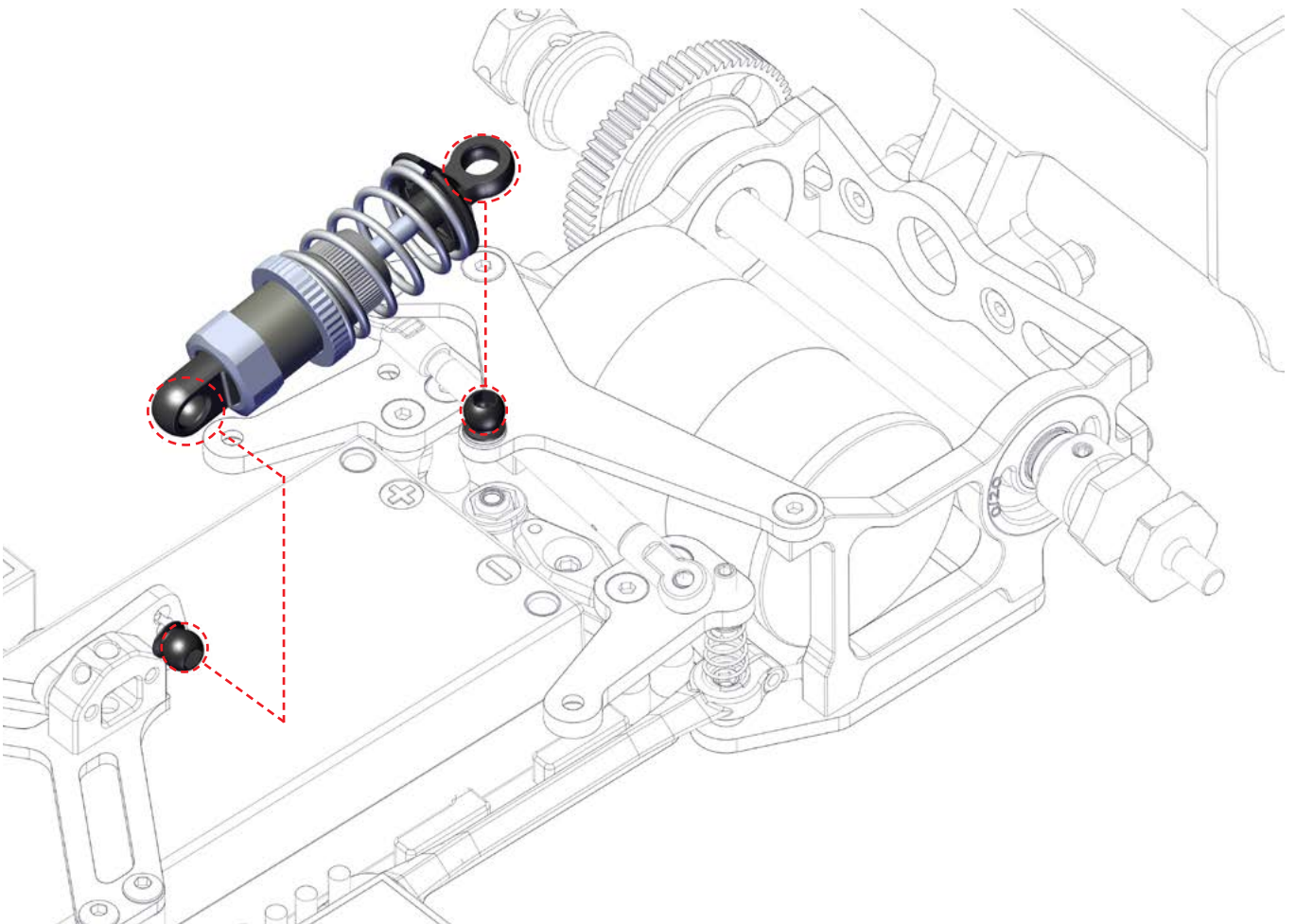

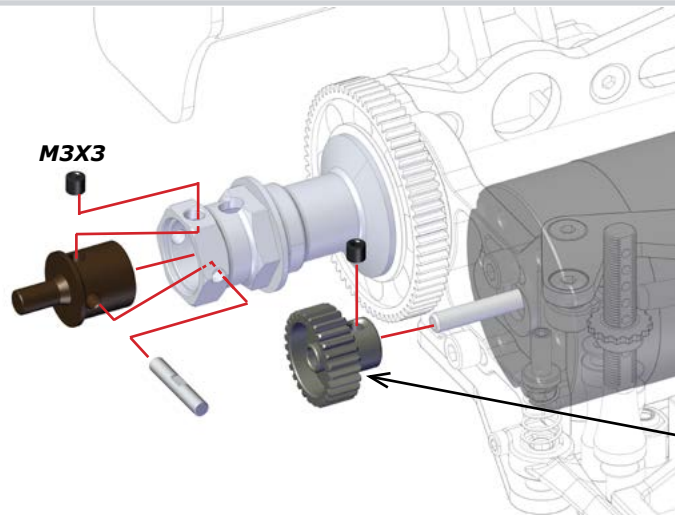
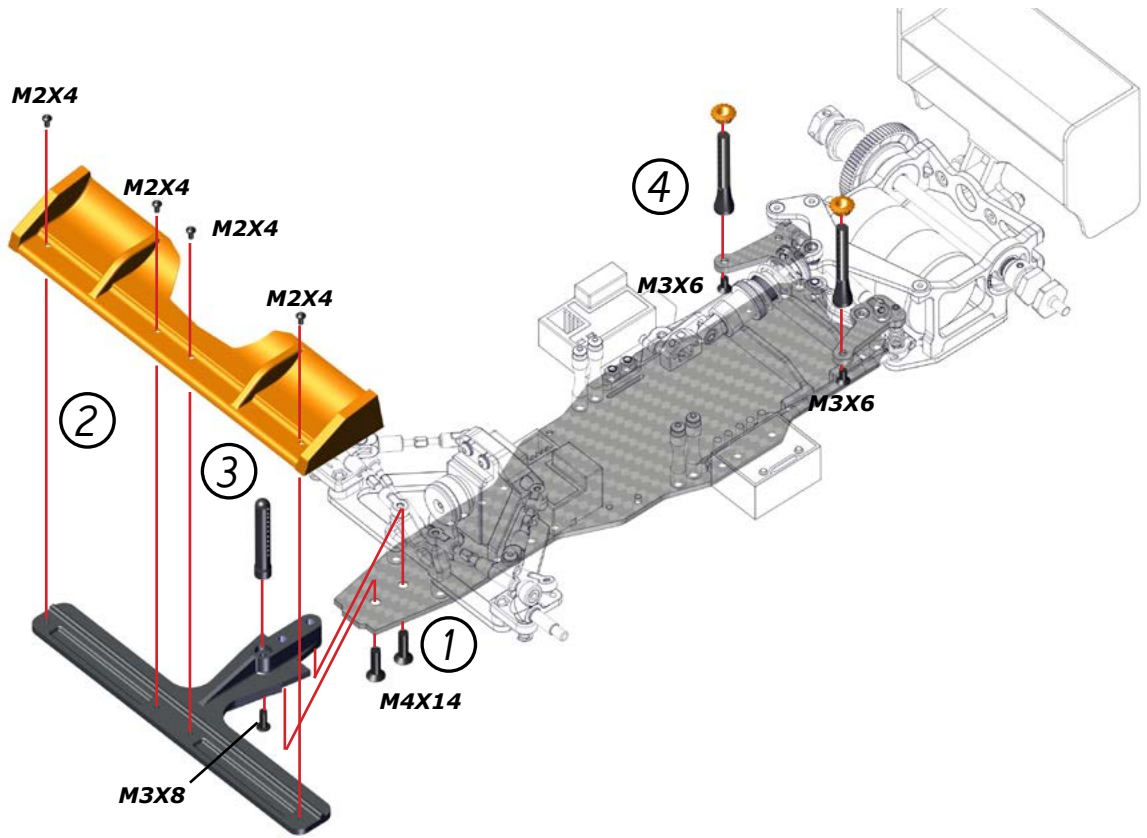

Pinion is **NOT INCLUDED** in the kit. Assemble the proper pinion for your set-up

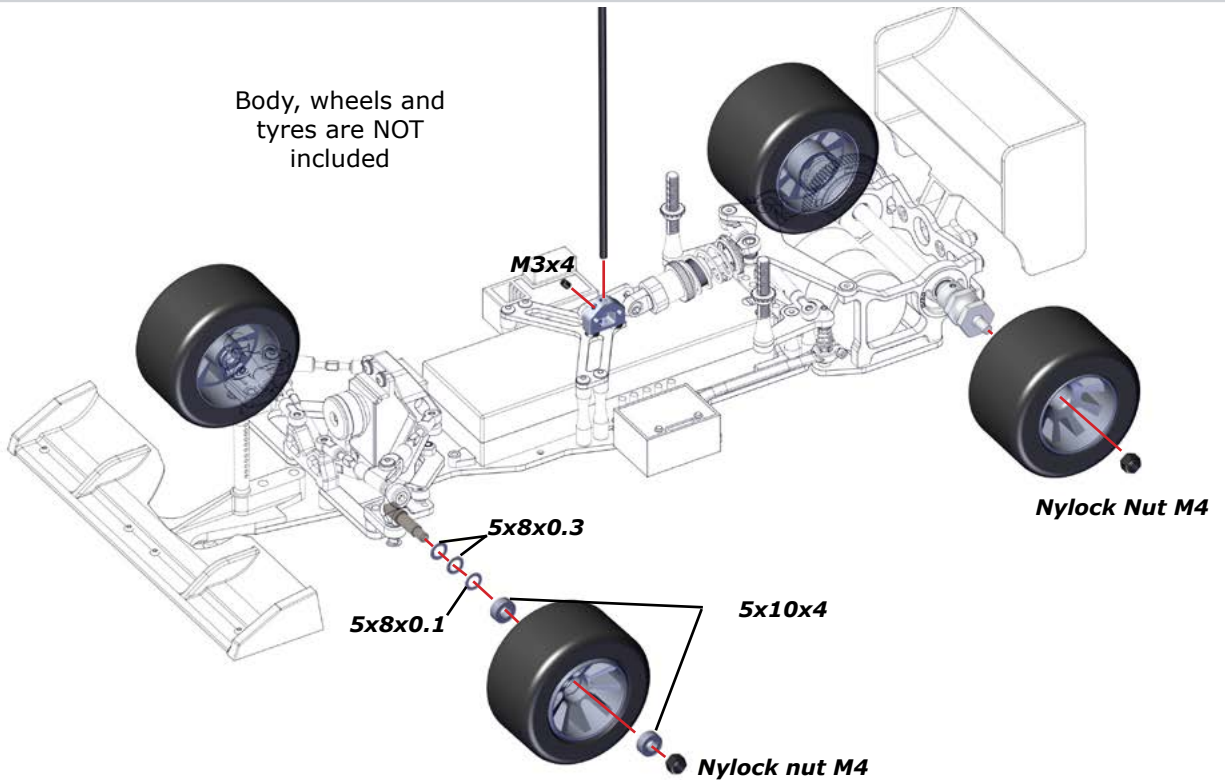

SECTION B: REFERENCE GUIDE

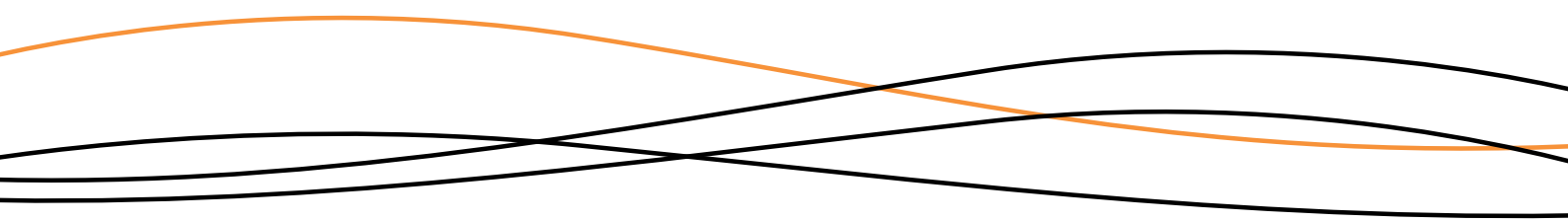

BALL DIFF ASSEMBLY

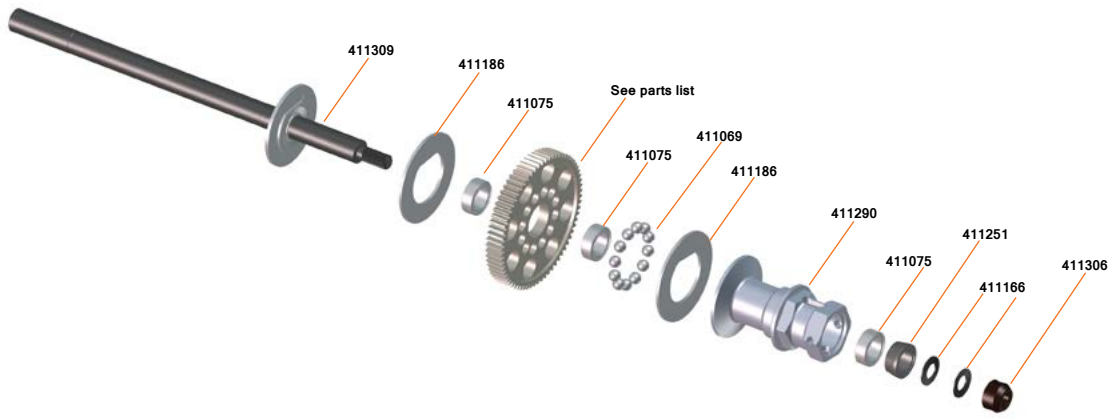

SHOCK ABSORBER ASSEMBLY

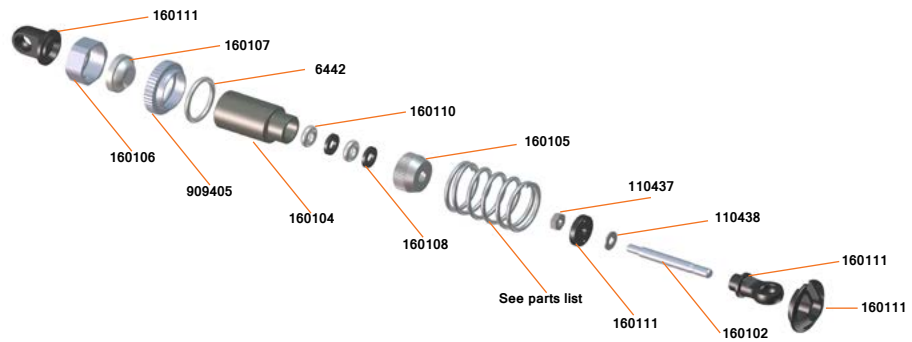

FINAL ASSEMBLY

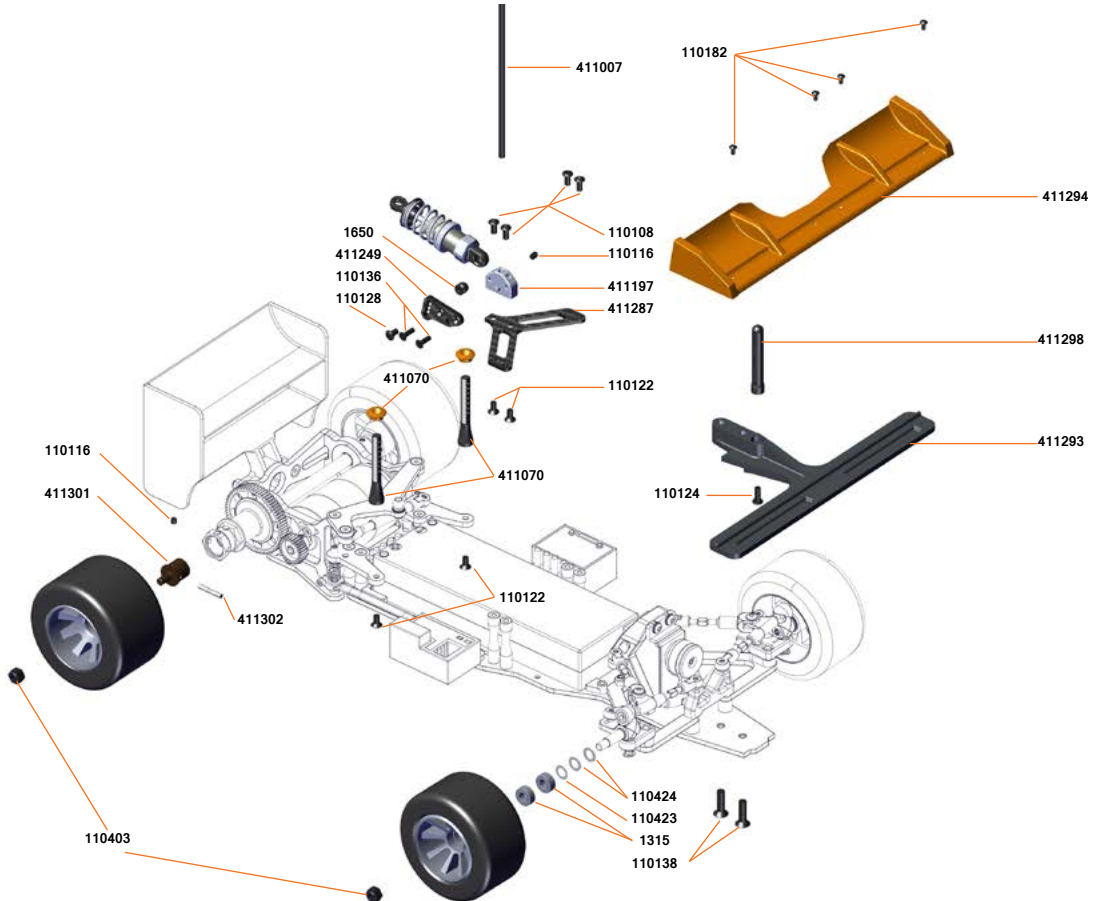

PARTS LIST

F110

410060 Serpent F110 1/10 2wd

Decals

1886 Decal Serpent black/white 1/10 (2)

1888 Decal Serpent chrome 1/10 (2)

411311 Decal b/w F110 (2)

FRONT SUSPENSION

401057 Trackrod M3x26mm (2)
 401582 Servo-saver 1/10 with inserts 23-24-25
 411042 Pivot ball front suspension (2)
 411048 Adjust nut for front suspension
 411060 Kingpin (2)
 411063 Pivot ball threaded upper arm (2)
 411143 Stop nut m3 low (10)
 411163 Snapping 2.3mm (10)
 411187 Pivotball with shaft (2)
 411206 Balljoint 4.5 (4)
 411207 Balljoint 4.5 short (2)
 411231 Steering blocks L+R S100
 411231 Steering blocks L+R S100
 411253 Pivotball uni 4.5mm (4)
 411283 Suspension arm L+R carbon F110
 411288 Servomount F110
 411293 Front bumper F110
 411294 Front wing F110 (big+small)
 411295 Front arm connector L+R F110
 411296 Front bulkhead F110
 411297 Front arm extensions lw L+R F110
 411298 Bodypost front F110 (2)
 411299 Wheelaxle front F110 (2)
 411300 Trackrod M3x36 (2)
 411305 Front rideheight shim set F110 (6)
 902138 Trackrod M3x23 (2)

Optional

401130 Trackrod M3x26mm alu (2)
 411106 Kingpin TiN
 411218 Front spring 22lbs S120L (2)
 411219 Front spring 18lbs S120L (2)
 411220 Front spring 26lbs S120L (2)
 411313 Front set wide F110
 411314 Suspension arm L+R wide carbon F110
 411315 Bulkhead F110 alu

CENTRAL ASSEMBLY

1650 Steel balls 5.8mm (4)
 411007 Antenna
 411070 Body mount rear (2)
 411192 Side-link S120L (2)
 411197 Center shock mount alu
 411199 Pivot ball S120L (5)
 411200 Pod pivot support S120L
 411201 Standoff alu S120L (2)
 411202 Spring retainer S120L (4)
 411207 Balljoint 4.5 short (2)
 411249 Shockbracket lower carbon S100
 411253 Pivotball uni 4.5mm (4)
 411259 Tube set S120L
 411282 Chassis carbon F110
 411286 Bodypost plate L+R carbon F110
 411287 Top plate carbon F110
 411291 Top plate post F110 (2)
 411308 Batterymount F110 (2)
 411310 Side electronics mount L+R carbon F110

Optional

411208 Side spring 4.5lbs S120L (2)
 411209 Side spring 5.0lbs S120L (2)
 411210 Side spring 5.5lbs S120L (2)
 411211 Side spring 6.0lbs S120L (2)
 411212 Side spring 6.5lbs S120L (2)
 411213 Side spring 7.0lbs S120L (2)
 411316 Screwset F110 gray alu (89)

REAR ASSEMBLY

411072 Bearing holder-set (9x2)

411284 Lower pod plate carbon F110
 411285 Top pod plate carbon F110
 411303 Pod bulkhead left F110
 411304 Pod bulkhead right F110
 411307 Rear pod support plate carbon F110
 411312 Rear wing F110 white
 411309 Rear axle F110
 411289 Wheelhub left F110

Optional

411292 Rear wing F110 black

DIFFERENTIAL

411069 Differential balls steel 1/8" (12)
 411166 Diff spring washer (4)
 411186 Diff washer S120L (2)
 411251 Rear axle cone S100/120
 411290 Diffhub F110
 411301 Diffhub insert F110
 411302 Diffhub lock pin F110 (2)
 411306 Diff adjust nut F110

Optional

411107 Diff balls. 1/8 ceramic (12)

SHOCK ABSORBERS

6442 O-ring adj.nut (10)
 160102 Shock RCM shaft short (2)
 160104 Shock RCM body alu (2)
 160105 Shock RCM bottom (2)
 160106 Shock RCM top nut (2)
 160107 Shock RCM membrane (4)
 160108 Shock RCM bushings (8)
 160110 Shock RCM bottom O-ring (8)
 160111 Shock RCM parts frame nylon short (14)
 160121 Shock top RCM shock (2)
 160122 Shock balljoint short on-road (2)
 909405 Shock adj nut alu +o-ring (4)

Optional

160109 Shock RCM bushing machined (8)
 160115 Shock RCM shaft short tin coated (2)
 160117 Shock piston RCM machined 1-hole (4)
 160118 Shock piston RCM machined 2-hole (4)
 160119 Shock piston RCM machined 3-hole (4)
 160120 Shock piston RCM machined 4-hole (4)
 160297 Spring grey short (2.6/14.8) TC (2)
 160298 Spring black short (2.9/16.5) TC (2)
 160299 Spring green short (3.5/19.9) TC (2)
 160300 Spring white L23 (2.3/13) (2)
 160301 Spring yellow L23 (2.8/16) (2)
 160302 Spring orange L23 (3.4/19.5) (2)

BODYMOUNT

411040 Body adjust nut (4)
 411070 Body mount rear (2)
 411286 Bodypost plate L+R carbon F110
 411298 Bodypost front F110 (2)

BEARINGS

1315 Ballbearing 5x10x4 (2)
 411074 Ball bearing flanged 1/4x3/8x1/8 (2)
 411075 Ball bearing 1/4x3/8x1/8 (2)

Body

170327 Body 1/10 F1 J191
 170328 Helmet set 1/10F1 (3)

Spurgears / Pinions

120024 Spur diff gear 64P/86T
 120025 Spur diff gear 64P/90T
 120026 Spur diff gear 64P/94T
 120111 Motor-pinion alu hard 64P / 24T
 120112 Motor-pinion alu hard 64P / 25T
 120113 Motor-pinion alu hard 64P / 26T
 120114 Motor-pinion alu hard 64P / 27T
 120115 Motor-pinion alu hard 64P / 28T

120116	Motor-pinion alu hard	64P / 29T
120117	Motor-pinion alu hard	64P / 30T
120118	Motor-pinion alu hard	64P / 31T
120119	Motor-pinion alu hard	64P / 32T
120120	Motor-pinion alu hard	64P / 33T
120121	Motor-pinion alu hard	64P / 34T
120122	Motor-pinion alu hard	64P / 35T
120123	Motor-pinion alu hard	64P / 36T
120124	Motor-pinion alu hard	64P / 37T
120125	Motor-pinion alu hard	64P / 38T
120126	Motor-pinion alu hard	64P / 39T
120127	Motor-pinion alu hard	64P / 40T
120128	Motor-pinion alu hard	64P / 41T
120129	Motor-pinion alu hard	64P / 42T

Hardware

110101	Screw allen countersunk m4x8 (10)
110102	Screw allen countersunk m4x10 (10)
110103	Screw allen countersunk m4x16 (10)
110104	Screw allen countersunk M3x8 (10)
110105	Screw allen countersunk m4x12 (10)
110106	Screw allen flanged roundhead m5x12 (10)
110107	Screw allen cilinderhead m3x16 (10)
110108	Screw allen roundhead m3x6 (10)
110109	Screw allen roundhead m3x10 (10)
110110	Screw allen roundhead m3x16 (10)
110111	Screw allen roundhead m3x14 (10)
110112	Screw allen roundhead m3x12 (10)
110113	Screw allen roundhead m4x8 (10)
110114	Setscrew allen m3x8 (10)
110115	Setscrew allen m3x4 (10)
110116	Setscrew allen m3x3 (10)
110117	Setscrew allen m3x12 (10)
110118	Setscrew allen m4x4 (10)
110119	Setscrew allen m4x6 (10)
110120	Setscrew allen m4x10 (10)
110121	Setscrew allen m5x6 (10)
110122	Screw allen countersunk m3x6 (10)
110123	Screw philips roundhead 3.5x13 (10)
110124	Screw allen roundhead m3x8 (10)
110125	Screw allen countersunk m3x20 (10)
110126	Screw allen countersunk m2.5x12 (10)
110127	Screw allen countersunk m3x12 (10)
110128	Screw allen roundhead m3x5 (10)
110129	Screw allen cilinderhead m3x10 (10)
110130	Screw allen roundhead m2.5x6 (10)
110131	Screw allen roundhead m2.5x10 (10)
110132	Screw allen countersunk m3x16 (10)
110133	Screw philipshead countersunk 2.5x8 wide (10)
110134	Screw philipshead countersunk 2.5x10 wide (10)
110135	Screw allen countersunk M2.5x10 (10)
110136	Screw allen countersunk M2.5x8 (10)
110137	Setscrew allen M3x6 (10)
110138	Screw allen countersunk M4x14 (10)
110139	Screw allen countersunk M3x40 (10)
110140	Screw allen roundhead M3x20 (10)
110141	Screw allen roundhead M3x22 (10)
110142	Screw allen roundhead M3x25 (10)
110143	Screw allen roundhead M4x18 (10)
110144	Screw allen roundhead M3x18 (10)
110145	Screw allen roundhead flanged M3x12 (10)
110146	Screw allen roundhead flanged M3x16 (10)
110147	Screw ph roundhead M2.5x5 (10)
110148	Setscrew allen M5x4 (10)
110149	Screw allen countersunk M2x10 (10)
110150	Screw M6x12 nylon black (2)
110151	Screw allen cilinderhead M4x10 (10)
110152	Screw allen cilinderhead M3x8 (10)
110153	Screw allen roundhead M2.3x4 (10)
110154	Setscrew allen M3x10 (10)
110155	Setscrew allen M3x5 (10)
110156	Screw allen countersunk M2.2x6 (10)
110157	Screw allen countersunk M3x5 (10)
110158	Screw allen countersunk M3x15 (10)
110159	Screw allen countersunk M3x18 (10)
110160	Screw allen cilinderhead M2.2x12 (10)

110161	Screw allen cilinderhead M2x6 (10)
110162	Setscrew allen M3x2.5 (10)
110163	Setscrew allen M3x2 (10)
110164	Screw allen roundhead M3x4 (10)
110165	Screw allen cilinderhead M2x5 (10)
110166	Screw allen countersunk M2.5x5 (10)
110167	Screw allen roundhead flanged M3x18 (10)
110168	Screw allen roundhead flanged M3.5x10 (10)
110169	Screw allen roundhead flanged M4x10 (10)
110170	Screw allen roundhead flanged M3x28 (10)
110171	Screw ph roundhead widethread 2.5x6 (10)
110172	Screw allen roundhead flanged M3X6 (10)
110173	Screw ph countersunk widethread 2.5x12 (10)
110174	Screw allen countersunk M4x6 (10)
110175	Screw allen cilinderhead M3x40 (10)
110176	Screw allen cilinderhead M3x18 (10)
110177	Screw allen roundhead M4x12 (10)
110178	Screw allen cilinderhead M3x14 (10)
110179	Screw allen roundhead M2.5x8 (10)
110180	Setscrew allen M5x10 (10)
110181	Screw M5x10 + Nut nylon black (4+4)
110182	Screw allen roundhead M2x4 (10)
110183	Screw allen countersunk M3x10
110184	Screw allen countersunk M3x14 (10)
110200	Pin 2.5x8 (10)
110201	Pin 3x12 (10)
110202	Pin 5x5 (10)
110203	Pin 3x14 (10)
110204	Pin 3x20 (10)
110205	Pin 3x22 (10)
110206	Pin 2.5x22 (10)
110207	Pin 2.5x12 (10)
110208	Pin nra 2x9.8 (4)
110209	Pin nra 2x18 (4)
110210	Pin 3x13 (10)
110211	Pin 2.5x13 (10)
110212	Pin 2.5x17 (10)
110213	Pin 2.5x10 (10)
110214	Pin 3x15 (10)
110215	Pin 2x12 (10)
110216	Pin 2.5x15 (10)
110217	Pin 2x9 (10)
110218	Pin 3x10 (10)
110219	Pin 2x14 (10)
110300	E-clip 2.3 (10)
110301	E-clip 3.2 (10)
110302	E-clip 4.0 (10)
110303	E-clip 5.0 (10)
110304	E-clip 7.0 (10)
110305	Seeger clip 12x1.0 (10)
110306	E-clip 6.0 (10)
110307	E-clip 9.0 (10)
110400	Shim 6.0x10x0.2(10)
110401	Shim3.2x7x0.5 (10)
110402	Nut nylock M3 (10)
110403	Nut nylock M4 (10)
110404	Shim 6x8x0.3 (10)
110405	Nut nylock M4 flanged (10)
110406	Nut nylock M2.2 (10)
110407	Nut M3 (10)
110408	Shim 3X5X0.3 (10)
110409	Shim 3X5X1 (10)
110410	Shim 3X5X2 (10)
110411	Shim 3X5X4 (10)
110412	Shim 3.5X8X1 (10)
110413	Shim 3.5X12X0.2 (10)
110414	Shim 3X6X0.1 (10)
110415	Shim 3X6X0.5 (10)
110416	Shim 3X6X0.8 (10)
110417	Shim 3X6X3 (10)
110418	Shim 4X8X0.1 (10)
110419	Shim 4X9.5X1 (10)
110420	Shim 4X9.5X2(10)
110421	Shim 4X9.5X4(10)
110422	Shim 4X10X0.3 (10)

110423	Shim 5X8X0.1 (10)	190507	Toolset FOR EP (16pcs) with Tools bag
110424	Shim 5X8X0.3 (10)	190509	Allen allen wrench 1.5 x 120mm
110425	Shim 5X10X0.3 (10)	190510	Allen wrench 2.0 x 120mm
110426	Shim 5X10X0.5 (10)	190511	Allen wrench 2.5 x 120mm
110427	Shim 5X15X0.3 (10)	190512	Allen wrench 3.0 x 120mm
110428	Shim 6.5X8X0.25 (10)	190513	Ball driver hex wrench 2.0 x 120mm
110429	Shim 6X11.75X0.2 (10)	190514	Ball driver hex wrench 2.5 x 120mm
110431	Shim 8X11X0.1 (10)	190515	Ball driver hex wrench 3.0 x 120mm
110432	Shim 8X11X0.2 (10)	190516	Tool tip allen wrench 1.5 x 120mm
110433	Shim 12X15X0.25 (10)	190517	Tool tip allen wrench 2.0 x 120mm
110434	Shim 12X18X0.3 (10)	190518	Tool tip allen wrench 2.5 x 120mm
110435	Shim 13X16X0.2 (10)	190519	Tool tip allen wrench 3.0 x 120mm
110436	Shim 3x5x3 (10)	190520	Tool tip ball driver hex wrench 2.0 x 120mm
110437	Nut M2.5 (10)		
110438	Shim 2.5x6x0.5 (10)	190521	Tool tip ball driver hex wrench 2.5 x 120mm
110439	Shim 3x7.5x1 (10)		
110440	Shim 2.5x5x0.4 (10)	190522	Tool tip ball driver hex wrench 3.0 x 120mm
110441	Nut nylock M3 flanged (10)		
110442	Shim 4x8x0.6 (10)	190523	Turnbuckle wrench 3mm
110443	Shim 5x15x0.2 (10)	190524	Turnbuckle wrench 4mm
110444	Nut M4 nylon (10)	190525	Turnbuckle wrench 5mm
110445	Shim 4x10x0.2 (10)	190526	Flat head screwdriver 3.0 x 150mm
110446	Shim 5x15x0.2 (10)	190527	Flat head screwdriver 4.0 x 150mm
110447	Shim 3x7x7 (10)	190528	Phillips screwdriver 2.0 x 45mm
110448	Shim 3x6x6 (10)	190529	Phillips screwdriver 3.5 x 120mm

Merchandising

1891	Serpent medium promo decal 20x12.5 (2)	190530	Phillips screwdriver 5.8 x 120mm
1892	Serpent windowshop decal 20x12.5 (2 sided)	190531	Nut driver 5.0 x 100mm
1893	Serpent decal XL (30x60cm)	190532	Nut driver 5.5 x 100mm
1895	Shopping-bag Serpent orange	190533	Nut driver 7.0 x 100mm
1896	Cap Serpent orange-black	190534	Reamer with end cap for lexan body
1897	Towel Serpent large	190535	Exhaust spring / caster clip remover
1898	Lanyard Serpent orange	190536	Wrench-glowplug / clutchnut - 10mm long
1998	Cap serpent black-orange	190537	Flywheel wrench tool wheelnut 1/8 off road
190156	Polo shirt Serpent black-orange (S)	190538	Flywheel wrench
190157	Polo shirt Serpent black-orange (M)		
190158	Polo shirt Serpent black-orange (L)		
190159	Polo shirt Serpent black-orange (XL)		
190160	Polo shirt Serpent black-orange (XXL)		
190161	Polo shirt Serpent black-orange (XXXL)		
190172	Winter jacket Serpent black-orange hooded (M)		
190173	Winter jacket Serpent black-orange hooded (L)		
190174	Winter jacket Serpent black-orange hooded (XL)		
190175	Winter jacket Serpent black-orange hooded (2XL)		
190176	Winter jacket Serpent black-orange hooded (3XL)		
190208	Winter jacket Serpent black-orange hooded (4XL)		
190188	T-shirt Serpent Splash orange (S)		
190189	T-shirt Serpent Splash orange (M)		
190190	T-shirt Serpent Splash orange (L)		
190191	T-shirt Serpent Splash orange (XL)		
190192	T-shirt Serpent Splash orange (XXL)		
190192	T-shirt Serpent Splash orange (XXXL)		
190193	T-shirt Serpent Splash black (S)		
190194	T-shirt Serpent Splash black (M)		
190195	T-shirt Serpent Splash black (L)		
190196	T-shirt Serpent Splash black (XL)		
190197	T-shirt Serpent Splash black (XXL)		
190198	T-shirt Serpent Splash black (XXXL)		
190201	Hoody sweater Serpent black-zip (S)		
190202	Hoody sweater Serpent black-zip (M)		
190203	Hoody sweater Serpent black-zip (L)		
190204	Hoody sweater Serpent black-zip (XL)		
190205	Hoody sweater Serpent black-zip (2XL)		
190206	Hoody sweater Serpent black-zip (3XL)		
190207	Hoody sweater Serpent black-zip (4XL)		

Pit equipment

190500	Pit-caddy
190501	Tool-bag
190502	Carry-bag medium. 3 drawers
190504	Ballcup tool
190506	Toolset FOR ONROAD (17pcs) with Tools bag



F110

