

SERPENT

Instruction
Manual



40TH ANNIVERSARY **VIPER**
989

WWW.SERPENT.COM

INTRODUCTION

The Serpent Viper 989 is designed to be a world champion, while still being easy to use, assemble, and set up. The Serpent Viper 989 offers state of the art specifications and leads the way in chassis design, using all the knowledge we have from 1/8 scale racing into this design too. Continuously pushing the performance envelope, Serpent's engineers have added new and innovative features that help take your Serpent Viper 989 into the winner's circle.

Designed by Michael Salven

Team Serpent
Multiple World Champions

INSTRUCTIONS

Serpent's long tradition of excellence extends to the instruction manuals, and this instruction manual is no exception. The easy-to-follow layout is richly illustrated with 3D-rendered full-color images to make your building experience quick and easy. Following the instructions will result in a well-built, high-performance race-car that will soon be able to unleash its full potential at the racetrack. The kit includes bags, with bag numbers, which refer to the same step in the manual. Open only the indicated bag(s) per step and finish that part of the assembly. Remaining parts will be needed later on in the assembly process.

PLASTIC PARTS

The Serpent moulded parts are very durable and hard. When assembling longer screws in new composite parts, make sure to use new hex bits in your (power) tools. Pre-threading also helps to avoid screw damage.

SETUP

In certain assembly steps you need to make basic adjustments, which will give you a good initial setup for your Serpent Viper 989. Fine-tuning the initial setup is an essential part of building a high-performance racecar like your Serpent Viper 989.

EXPLODED VIEWS AND PARTS LIST

The exploded views and parts lists for the Serpent Viper 989 are presented in the Reference Guide section in the back of this manual. The exploded views show all the parts of a particular assembly step along with the Serpent part number and hotlink to the Serpent website. Part numbers in orange indicates that this part is an optional. Optionals part names and numbers are showed below.

CUSTOMER SERVICE

Serpent has made a strong effort to make this manual as complete and clear as possible. Additional info may be published in our website: www.serpent.com or you may ask your dealer or the Serpent distributor for advice, or email Serpent direct: info@serpent.com. The Serpent Facebook, Twitter and Youtube pages give additional means of support and communications.

SAFETY

Read and take note of the 'Read this First section' before proceeding to assemble the car-kit. This car-kit is intended for persons aged 16 or older.

READ THIS FIRST!

- This is a highly technical hobby product, intended to be used in a safe racing environment. This car is capable of speeds in excess of 80 km/h or 50mph. Please follow these guidelines when building and operating this model.
- Parental guidance is required when the builder/user of this car is under 16.
- Follow the building instructions. If in doubt, contact your dealer or importer.
- Be sure to use the proper tools when assembling the car. Always exercise caution when using electric tools, knives and other sharp objects.
- Be careful when using liquids like lubrication oil, fuel or glue. Do not swallow.
- Follow the manufacturer's instruction in case you experience irritation after using the product.
- Be careful when operating the car. Stay away from any rotating parts such as wheels, gears and transmission. Stay away from motor, engine and exhaust pipe system or speedo during and immediately after use, as these parts may be very hot. We advise to use protective hand gloves.
- Only operate this car in a safe environment, like a special racing track or a closed parking lot. Avoid using this car on public roads, crowded places or near infants.
- Before operating this car, always check the mechanical status of the car. Also check that the transmitter and receiver frequencies correspond and are not used by any other racer at the same time. Check that the batteries of the transmitter and receiver- are fully charged.
- After use, always check all the mechanics of the car. We advise to clean the car immediately after use, and inspect the parts for wear or fractures. Replace when necessary. Do not use water, methanol, thinner or other solvents to clean the car.
- Empty the fuel tank (depending on model) if needed and disconnect the receiver battery.
- Store the car in a dry and heated place to avoid corrosion of metal parts.
- Avoid using this car in wet conditions as the water will cause corrosion on the metal parts and bearings and these parts will cease to function properly. If driven in the wet, ensure that all the electric equipment is waterproofed and after use, that all moving parts are dried immediately.

CONTENTS

•		
•	REAR ASSEMBLY	4
•	GEARBOX ASSEMBLY	17
•	FRONT I ASSEMBLY	18
•	RADIO ASSEMBLY	25
•	FRONT II ASSEMBLY	31
•	SHOCKS ASSEMBLY	34
•	CLUTCH ASSEMBLY	39
•	FINAL ASSEMBLY	41
•	EXPLODED VIEWS	46
•	TEAM SERPENT NETWORK	56



LINES DESCRIPTION

Each step contains a variety of numbers, lines, and symbols. The numbers represent the order in which the parts should be assembled. The lines are described below.



Step number; the order in which you should assemble the indicated parts



Length after assembly



Assembly path of one item into another



Group of items (within lines) should be assembled first



Direction the item should be moved



Glue one item to another



Connect one item to another



Gap between two items



Press/Insert one item into another

ICONS DESCRIPTION

Each step contains a variety of symbols described below.



Carefull, read and check very well.



Apply a small amount of cyano glue. Use wear protection for eyes and hands.



Detail view to explain assembly or order of parts better.



Default set-up: This symbol indicates the default setup.



Grease: apply a small amount of grease to the parts shown.



Silicone grease: apply a small amount of grease to the parts shown.



Thread lock: apply a small amount on the parts shown. Before to apply the threadlock, make sure to degrease the parts very well, as otherwise the threadlock will not work.



Silicone oil: use the indicated silicone oil for the shocks and differentials.



Oil: apply a small amount of oil to the parts shown.



Left and right parts should be assembled in the same way.



Parts or items not included in the kit.





Optional part, not standard in the kit.

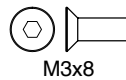
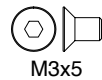
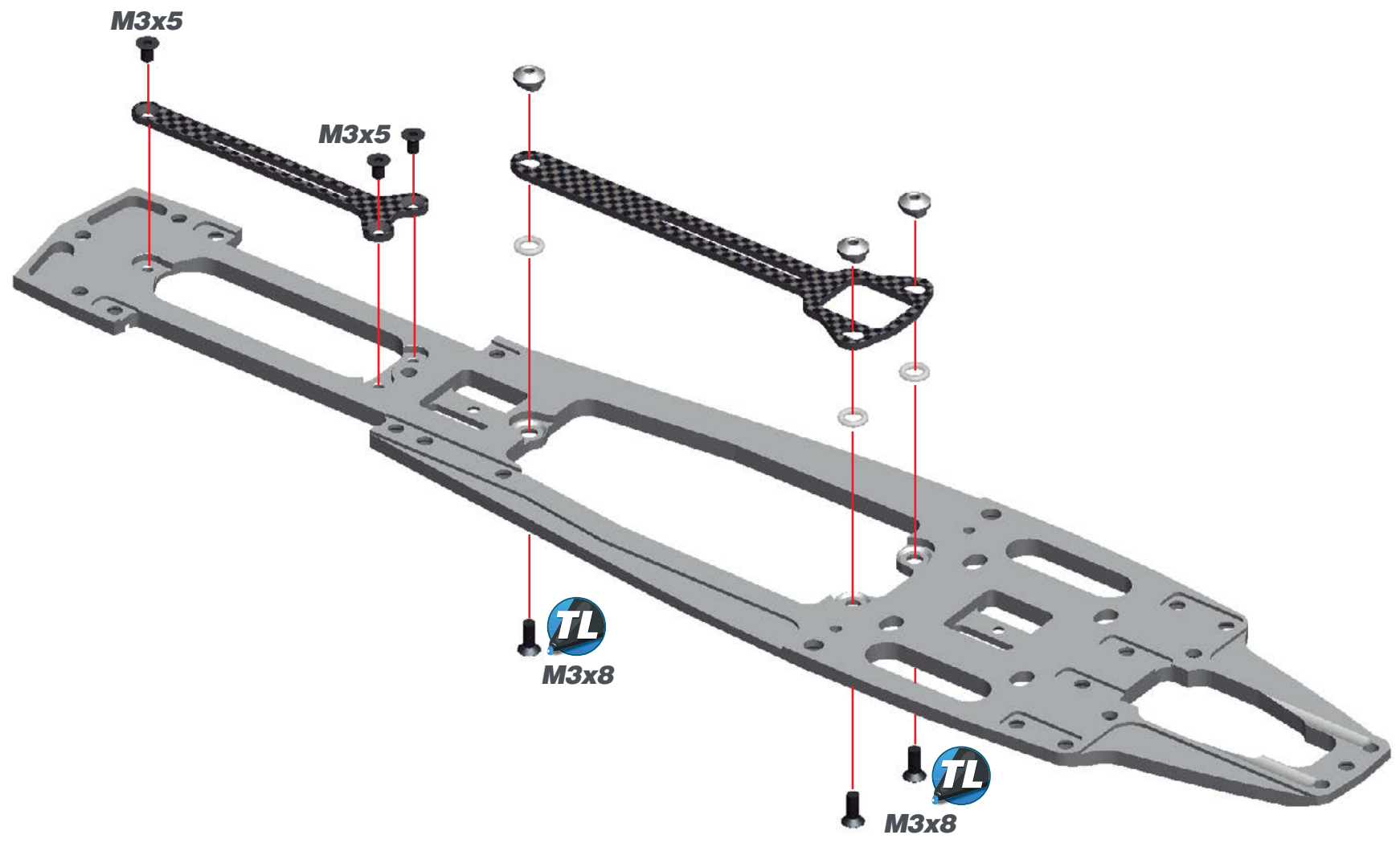

STEP 1 BAG 1

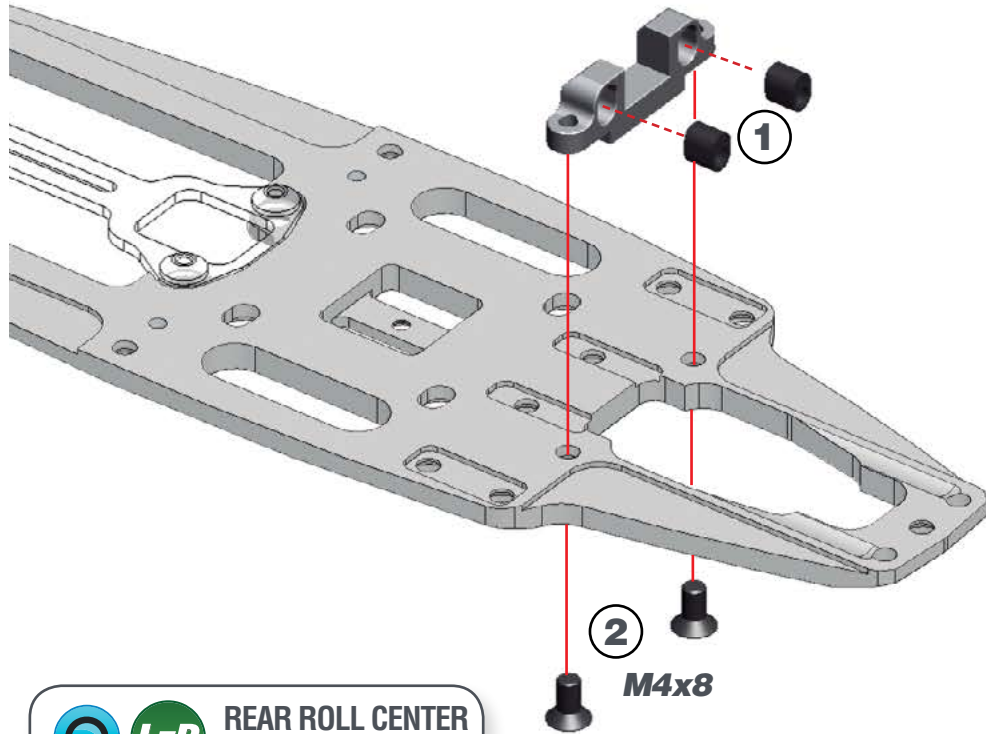

STEP 2



 **L=R** REAR ROLL CENTER
INSERTS CHART

  



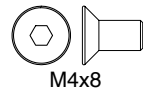

STEP 3

L=R

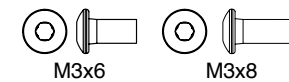
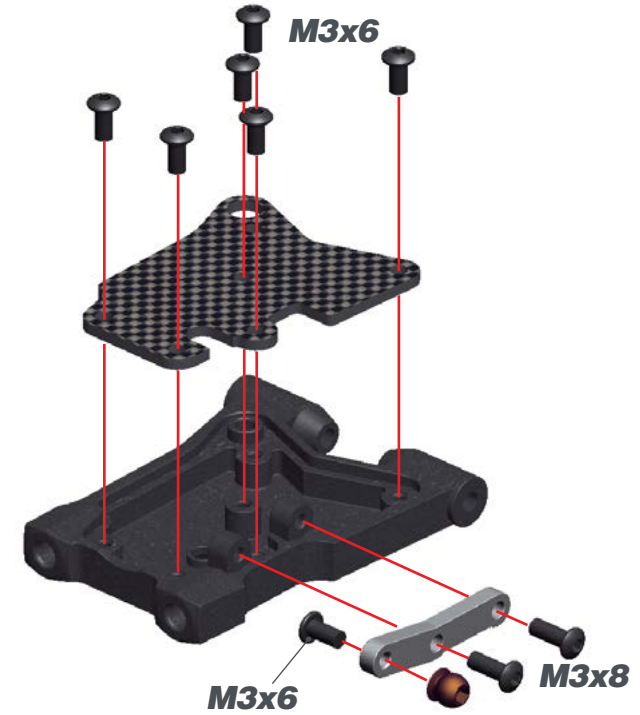

STEP 4

L=R



M4x10

L=R REAR ANTIROLL BAR ROD LENGTH

32.5mm

STEP 5

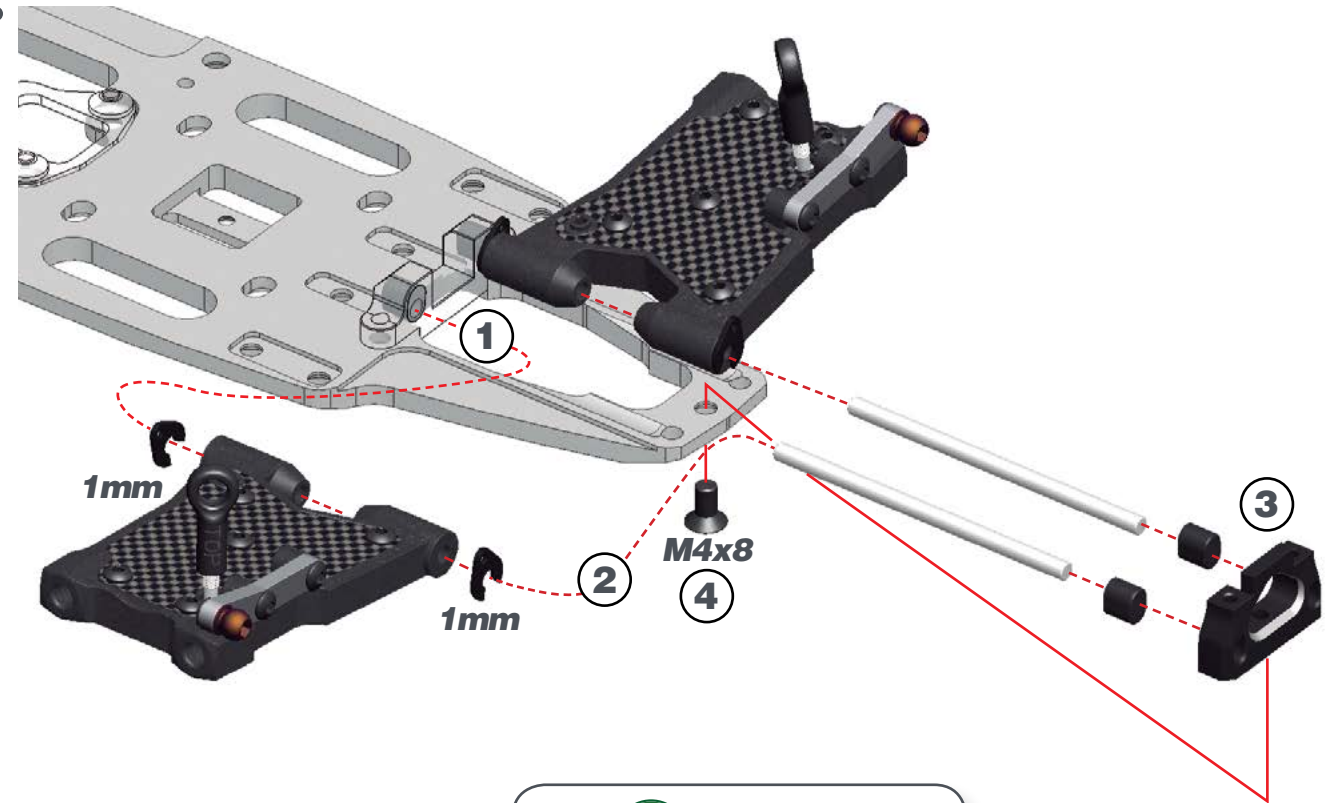

L=R REAR ROLL CENTER INSERTS CHART

DEF. SETUP

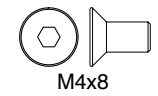
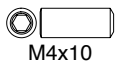

STEP 6

BAG 2

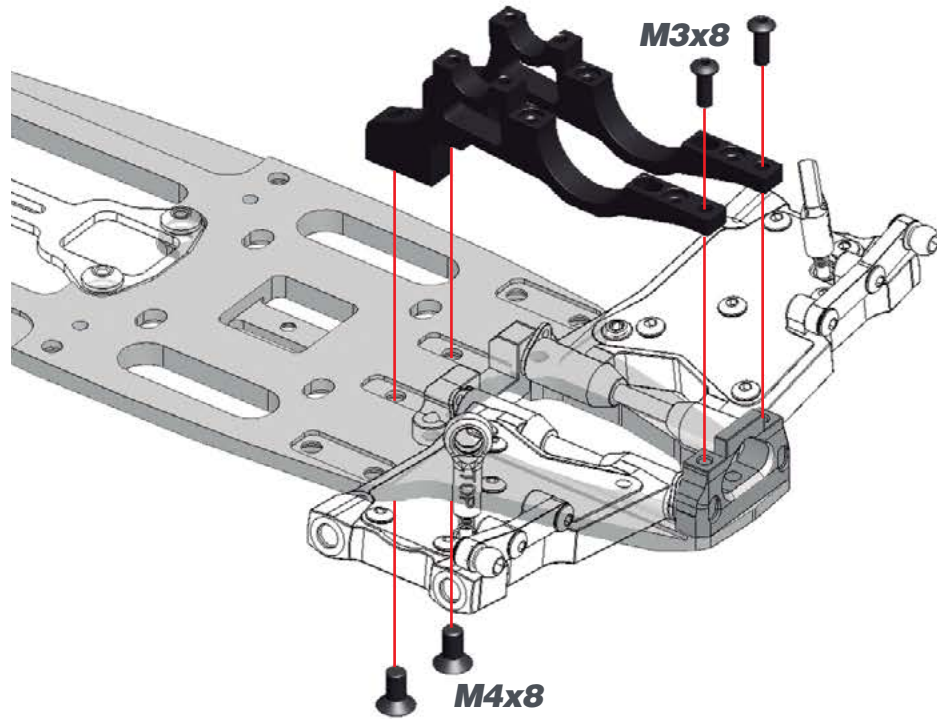

STEP 7

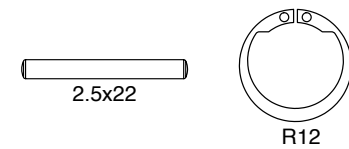
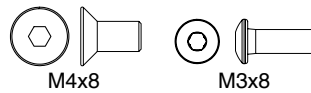
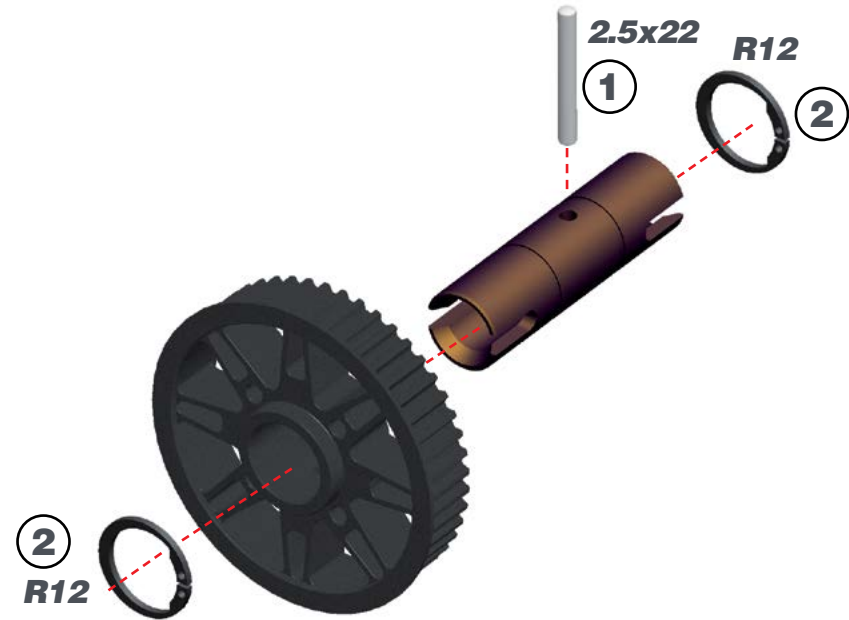

STEP 8



REAR SOLID AXLE EXCENTERS

Note that the rear solid axle excenters are not symmetrical and are marked with L (=left) and R (=right).

LEFT

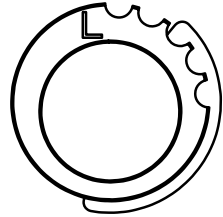

RIGHT

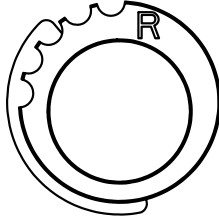

REAR BELT TENSION

Use the central slot as starting position

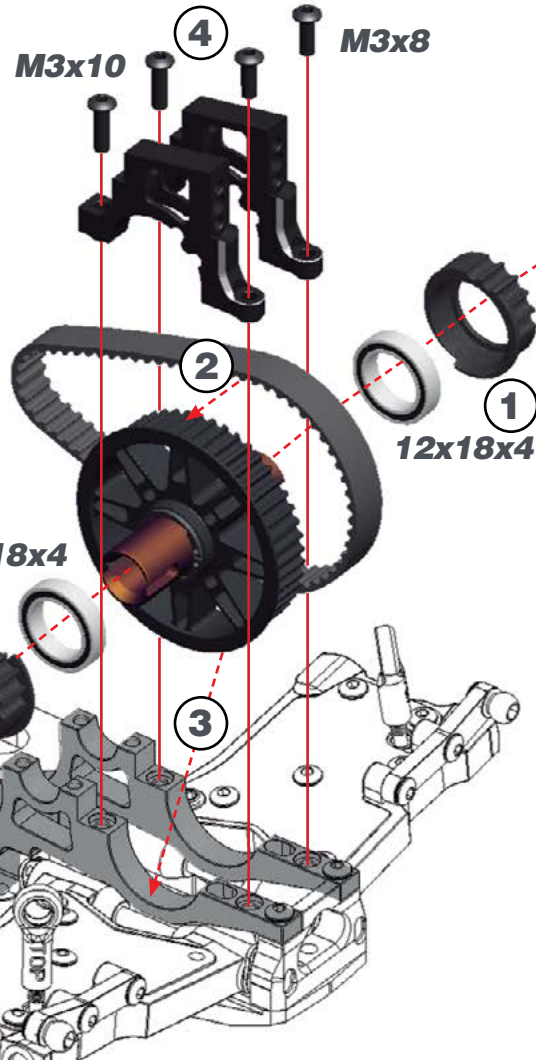
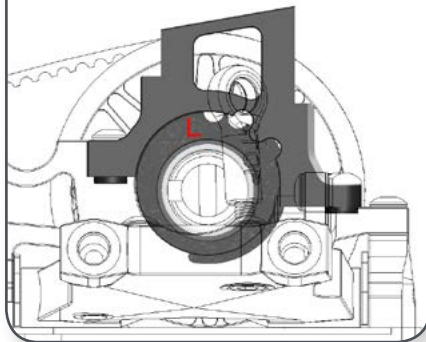

STEP 9

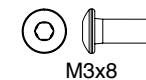
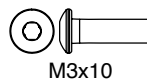
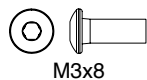
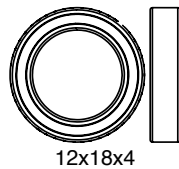
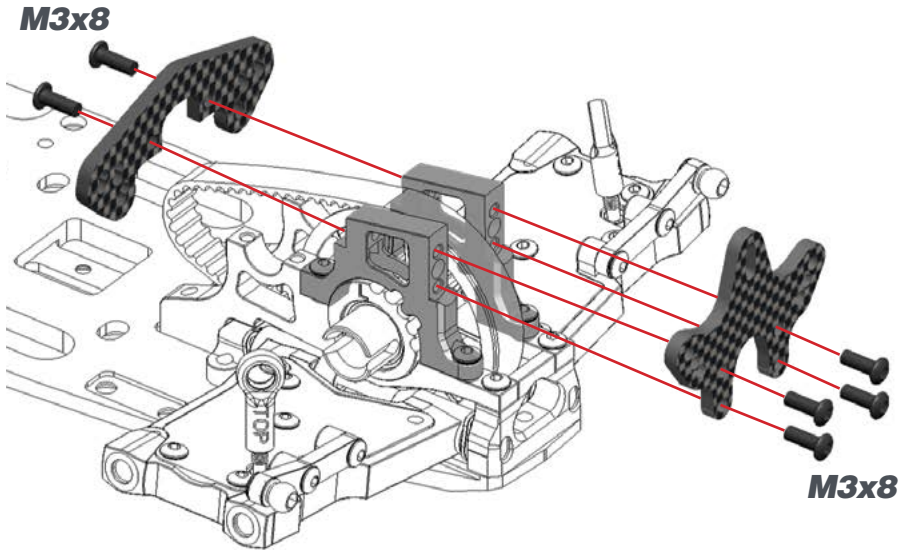

STEP 10

10.1

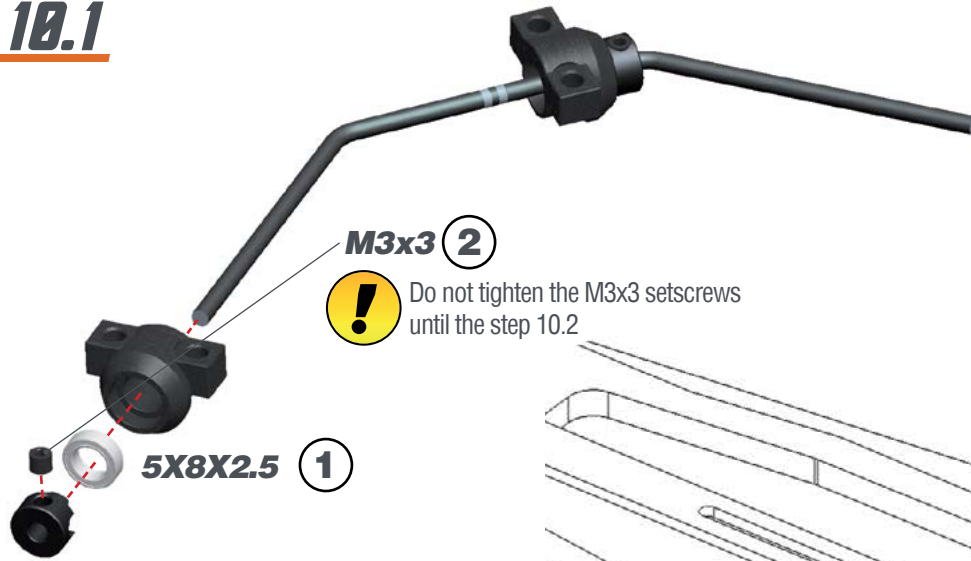

M3x3 ②

! Do not tighten the M3x3 setscrews until the step 10.2

5X8X2.5 ①

10.2

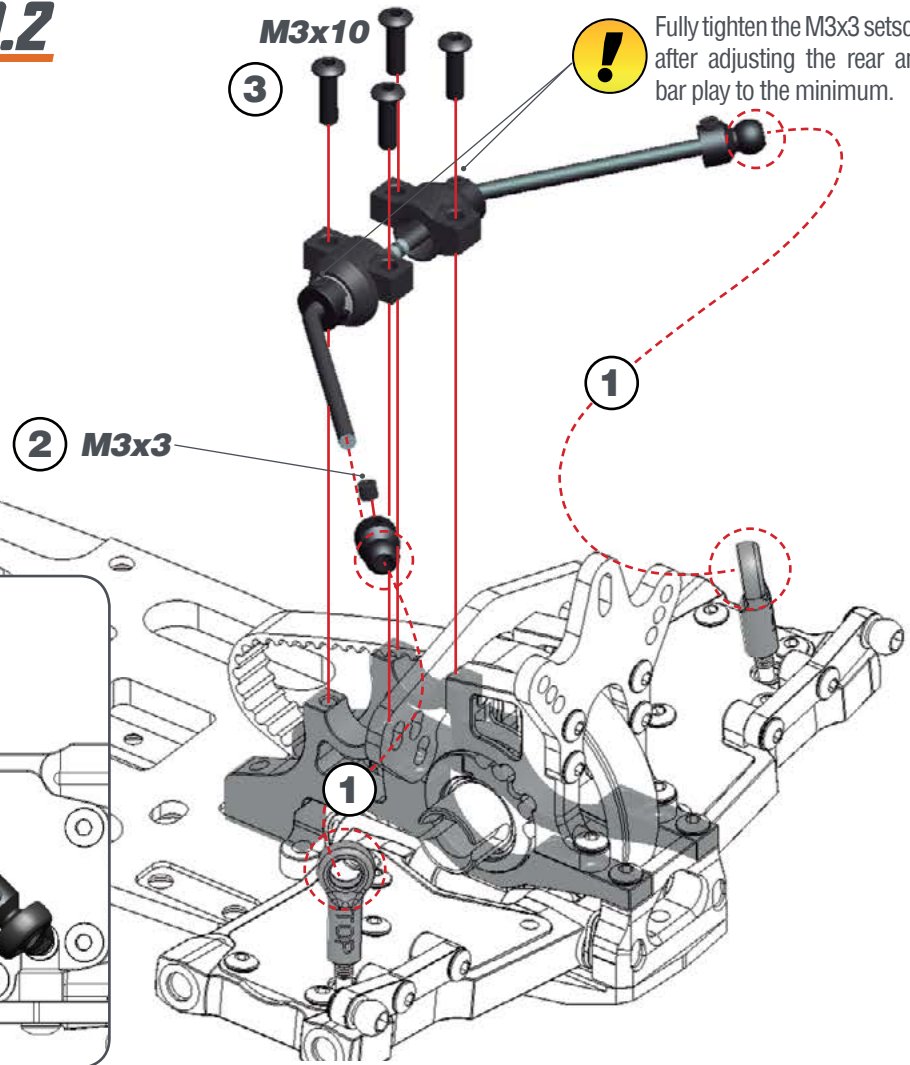

M3x10 ③

! Fully tighten the M3x3 setscrews after adjusting the rear antiroll bar play to the minimum.

② M3x3

①

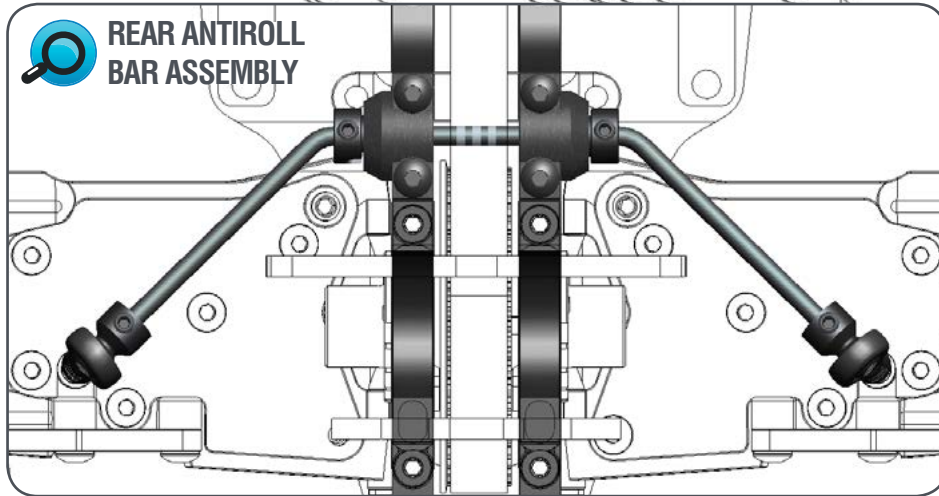

REAR ANTIROLL BAR ASSEMBLY



M3x3



5x8x2.5

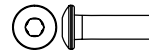

M3x10

STEP 11 **BAG 3**

11.1

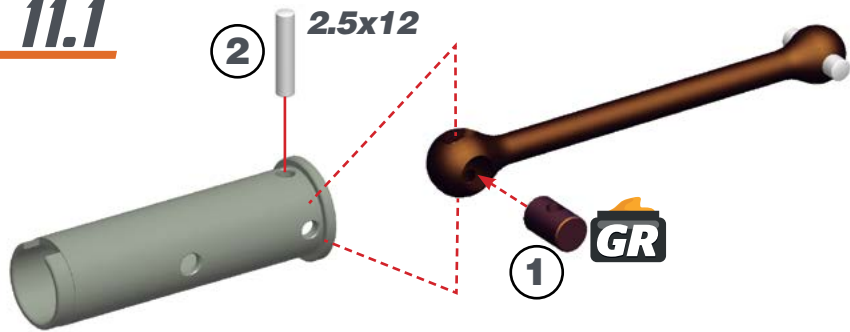

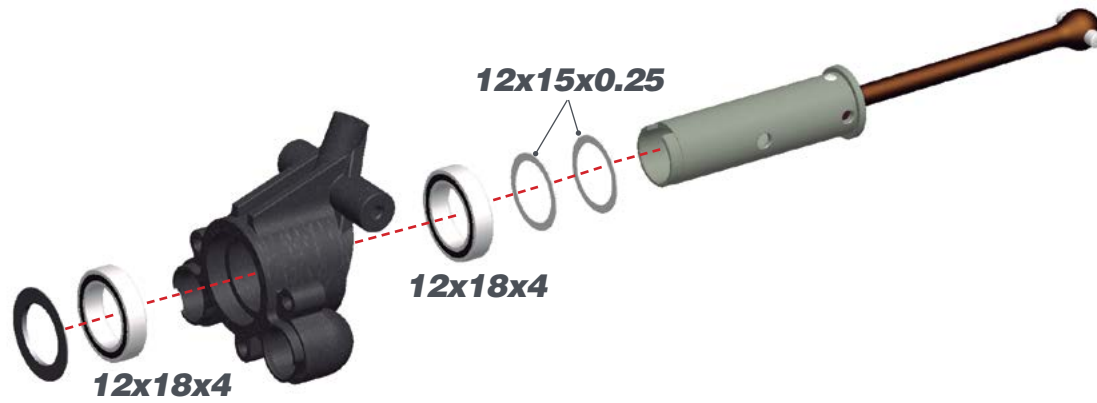

11.2

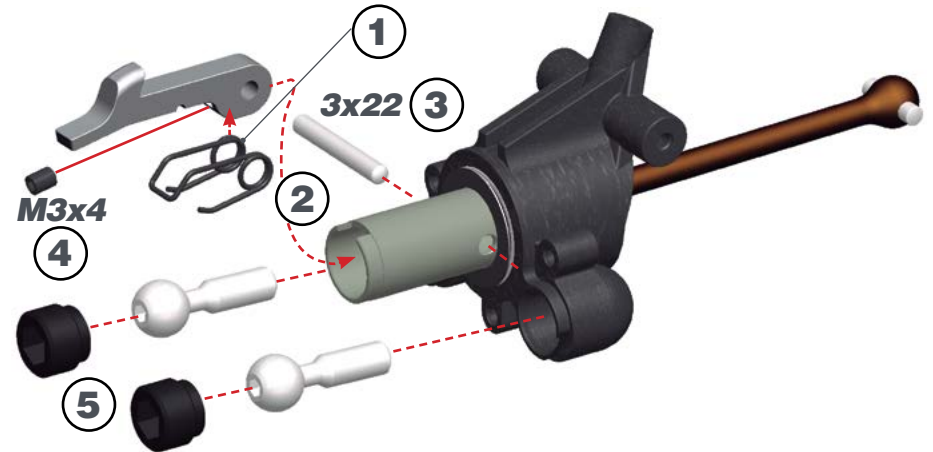

11.3



 1- Note orientation of the outside wheel axle shim.
 2- Note position of the lever spring.

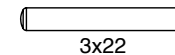
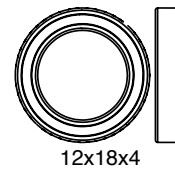
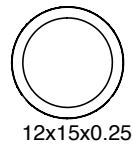
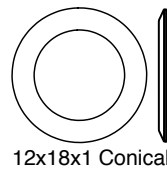

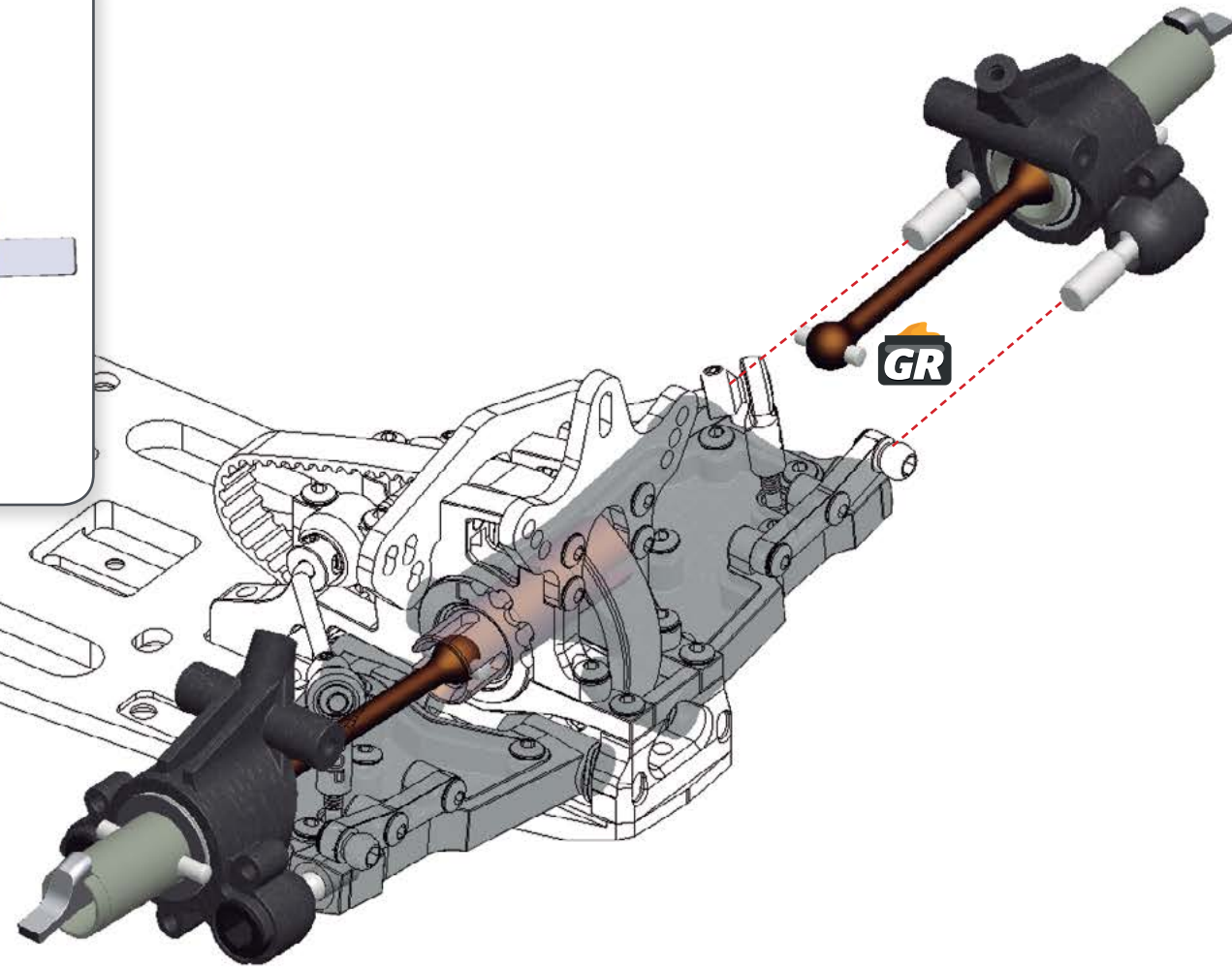
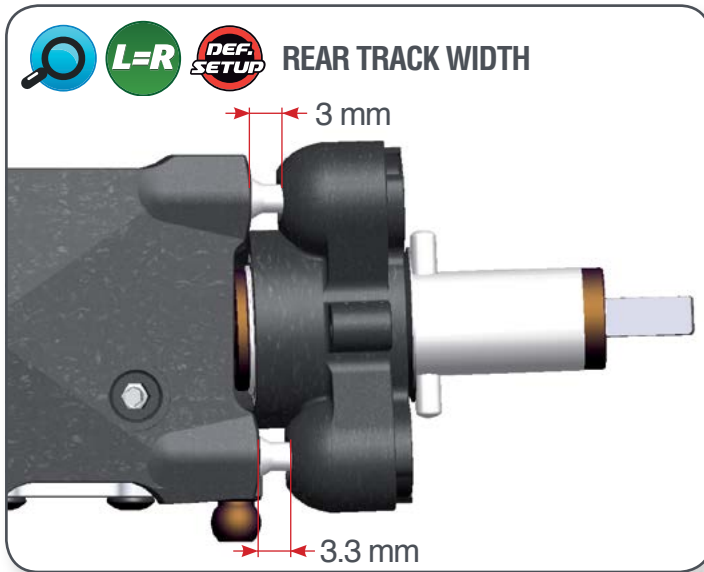

STEP 12

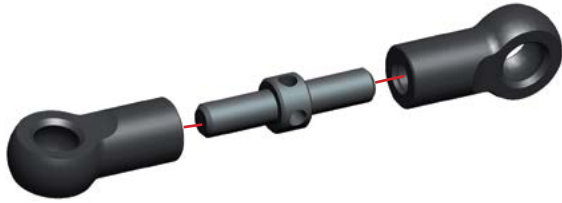

STEP 13

13.1



13.2

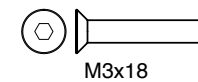
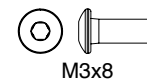
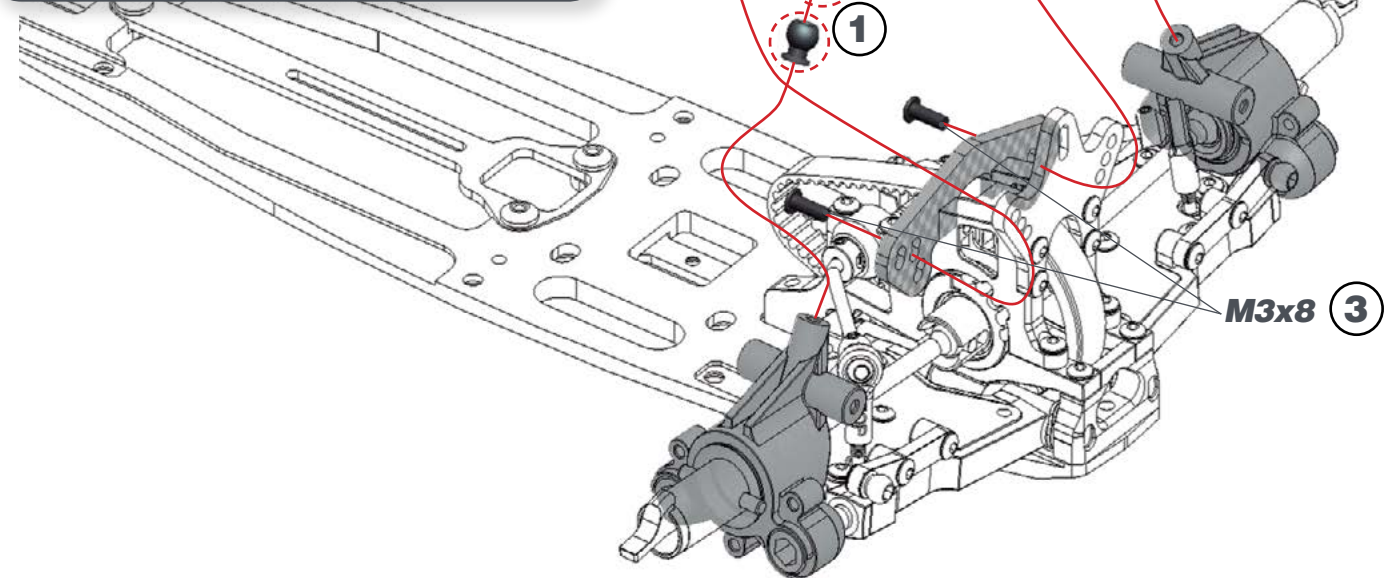
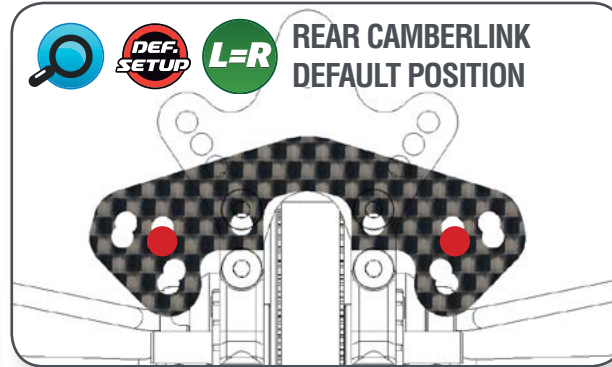

STEP 14 **BAG 4**

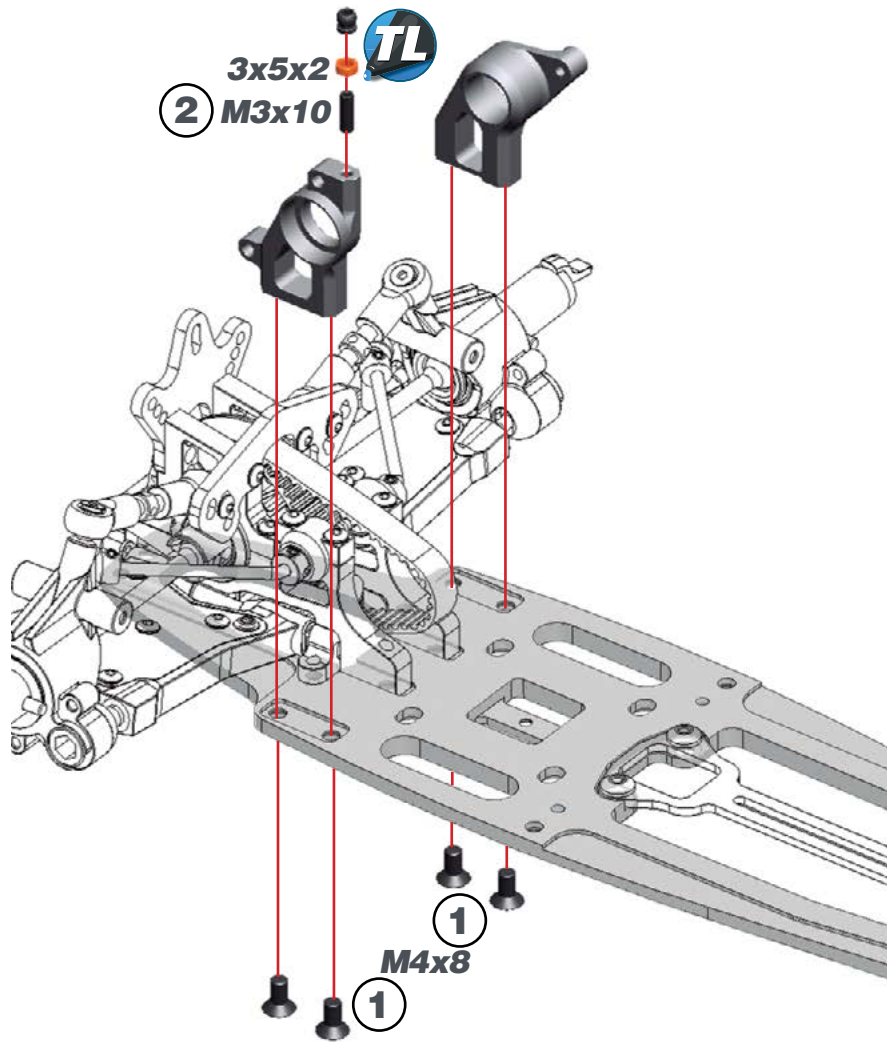

STEP 15

15.1

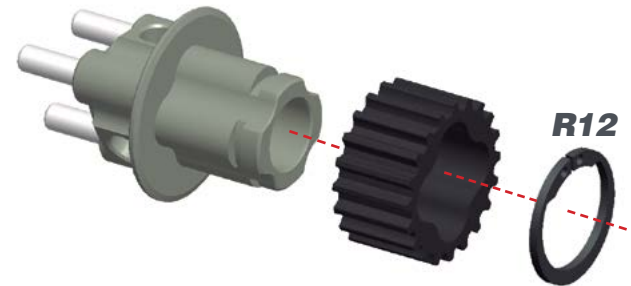

15.2

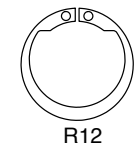
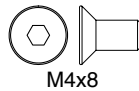
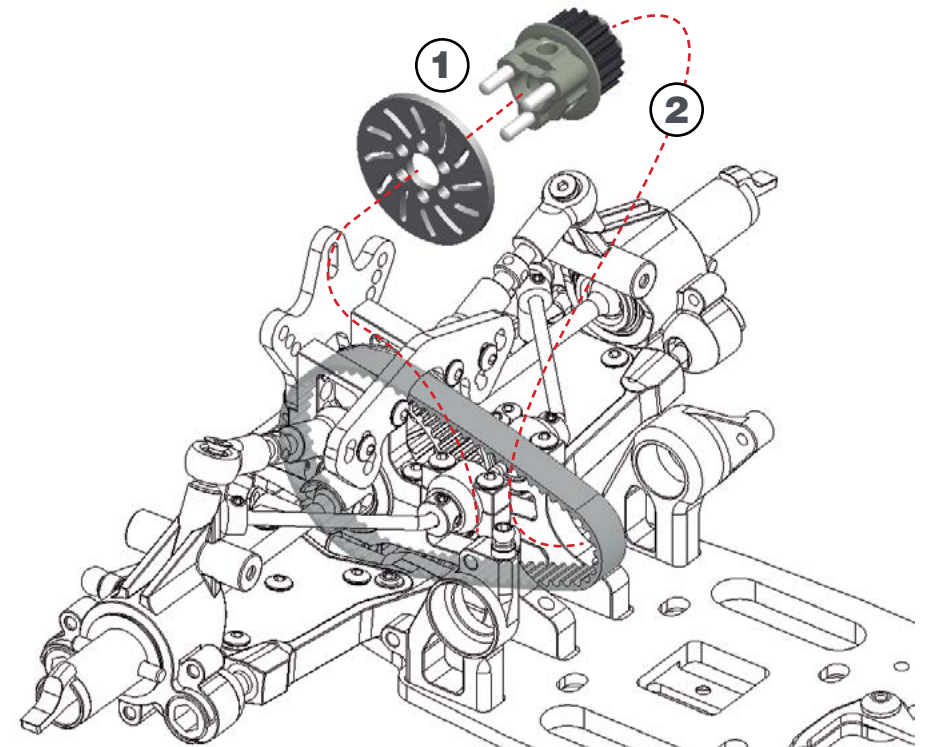

STEP 16

16.1



16.2

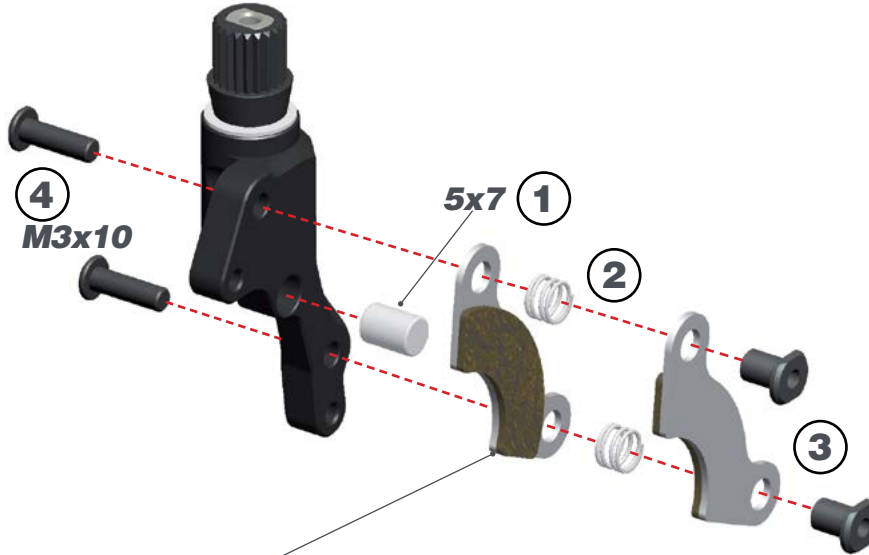

! After tightening the M3x10 screws check that the brake pads slide easy over the bushings.

16.3

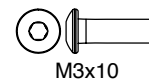
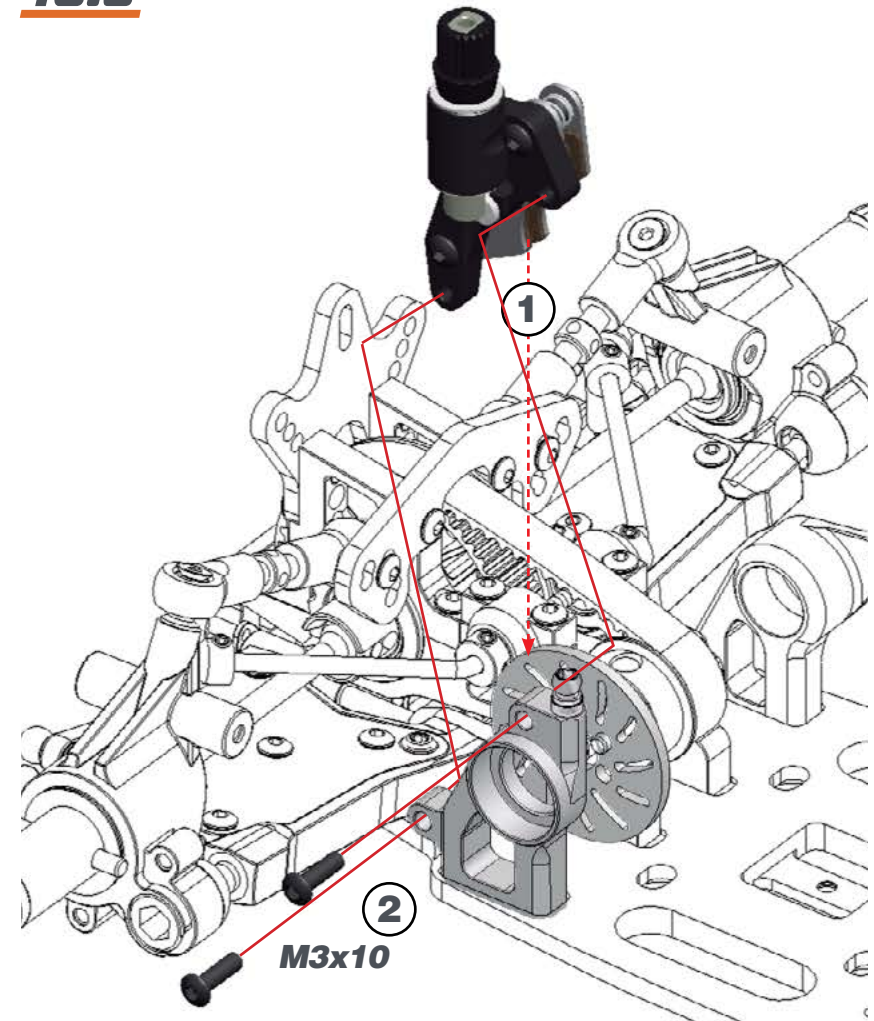

STEP 17 BAG 5

17.1

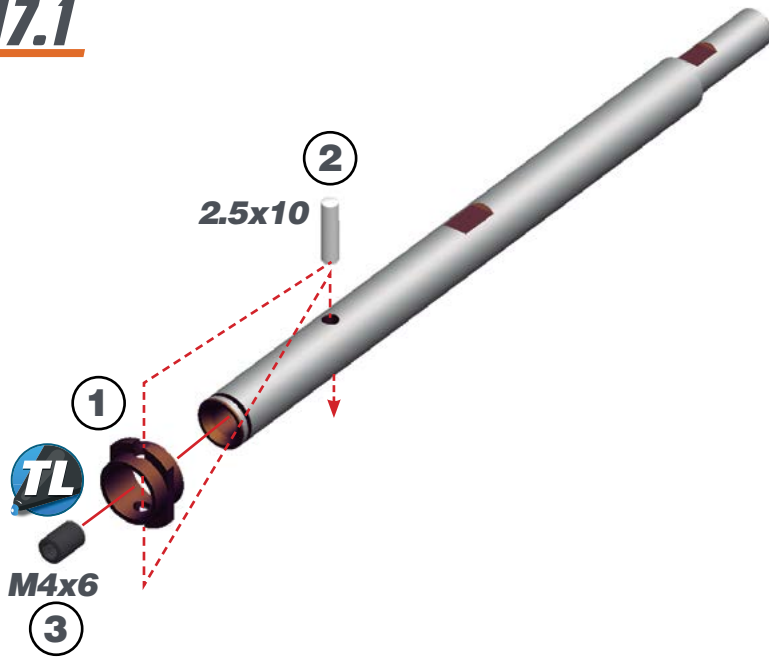

17.2

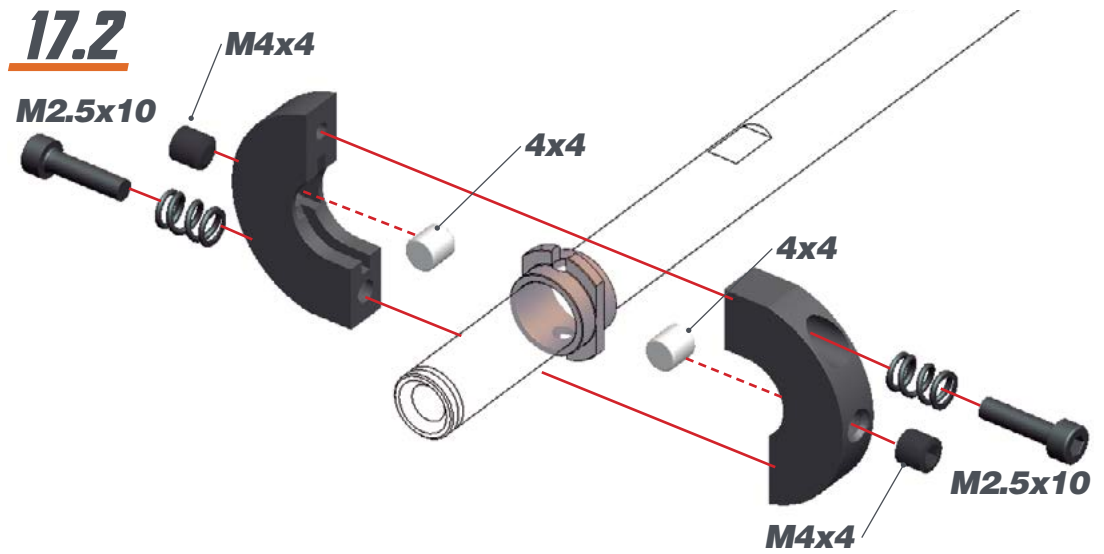

! 1- The M2.5x10 screws adjust the SHIFT POINT. As default adjustment screw them until the screws will be leveled with the hole as in the right pictures.

2- Adjust the M4x4 screw to minimise the gap between the shoes and the bell, but still spinning free without touching. Check after each run.

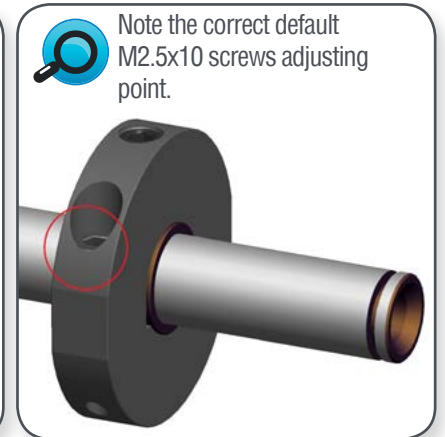
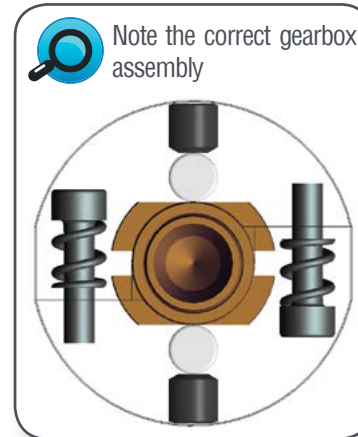

STEP 17

17.3

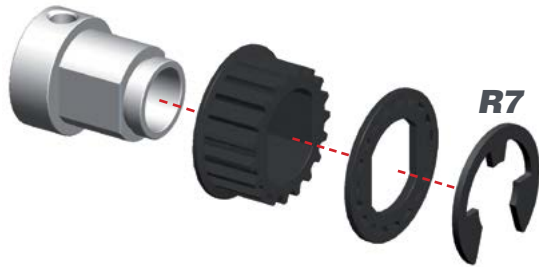

17.4



Adjust the position of the side pulley to have a little play on the 2-speed shaft.

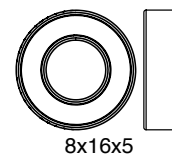
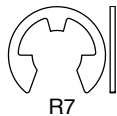
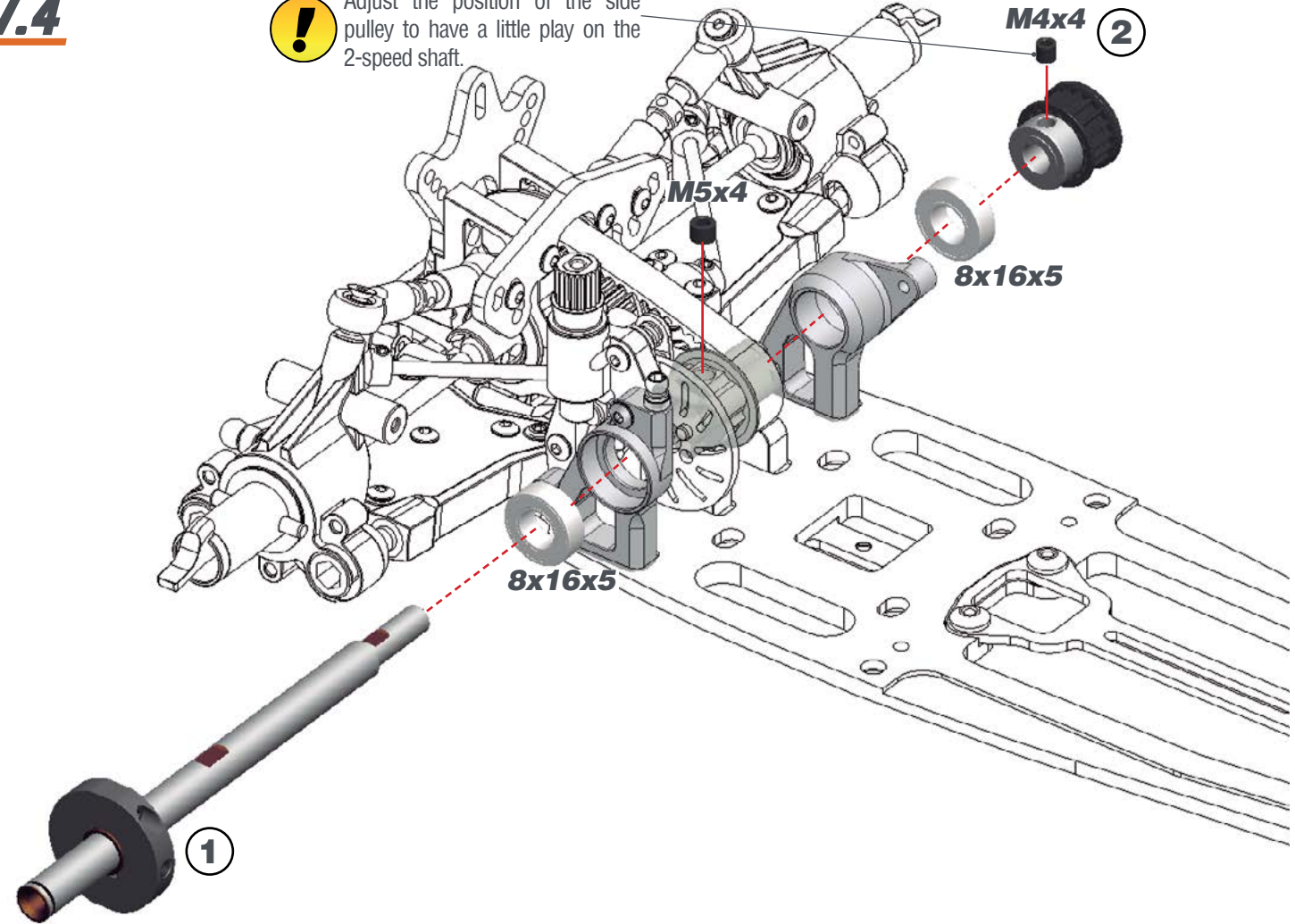

STEP 18

18.1

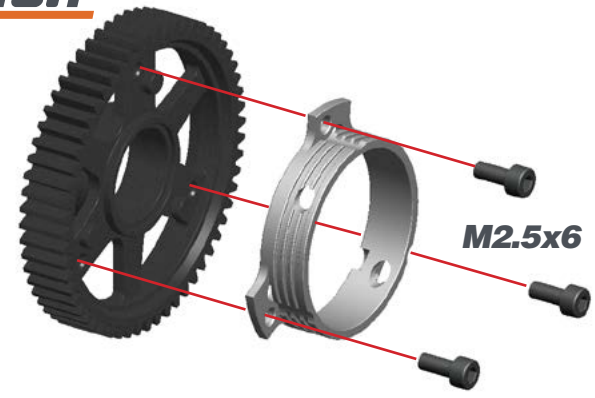

18.2

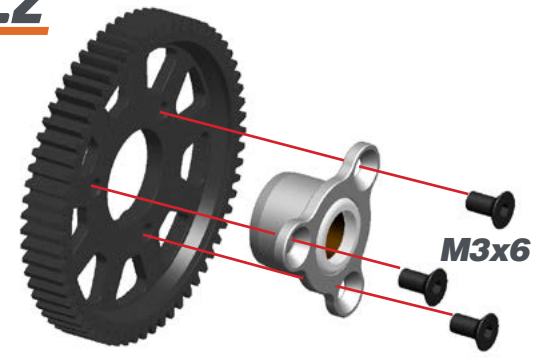

18.3

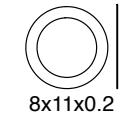
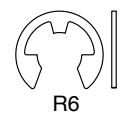
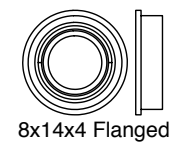
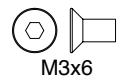
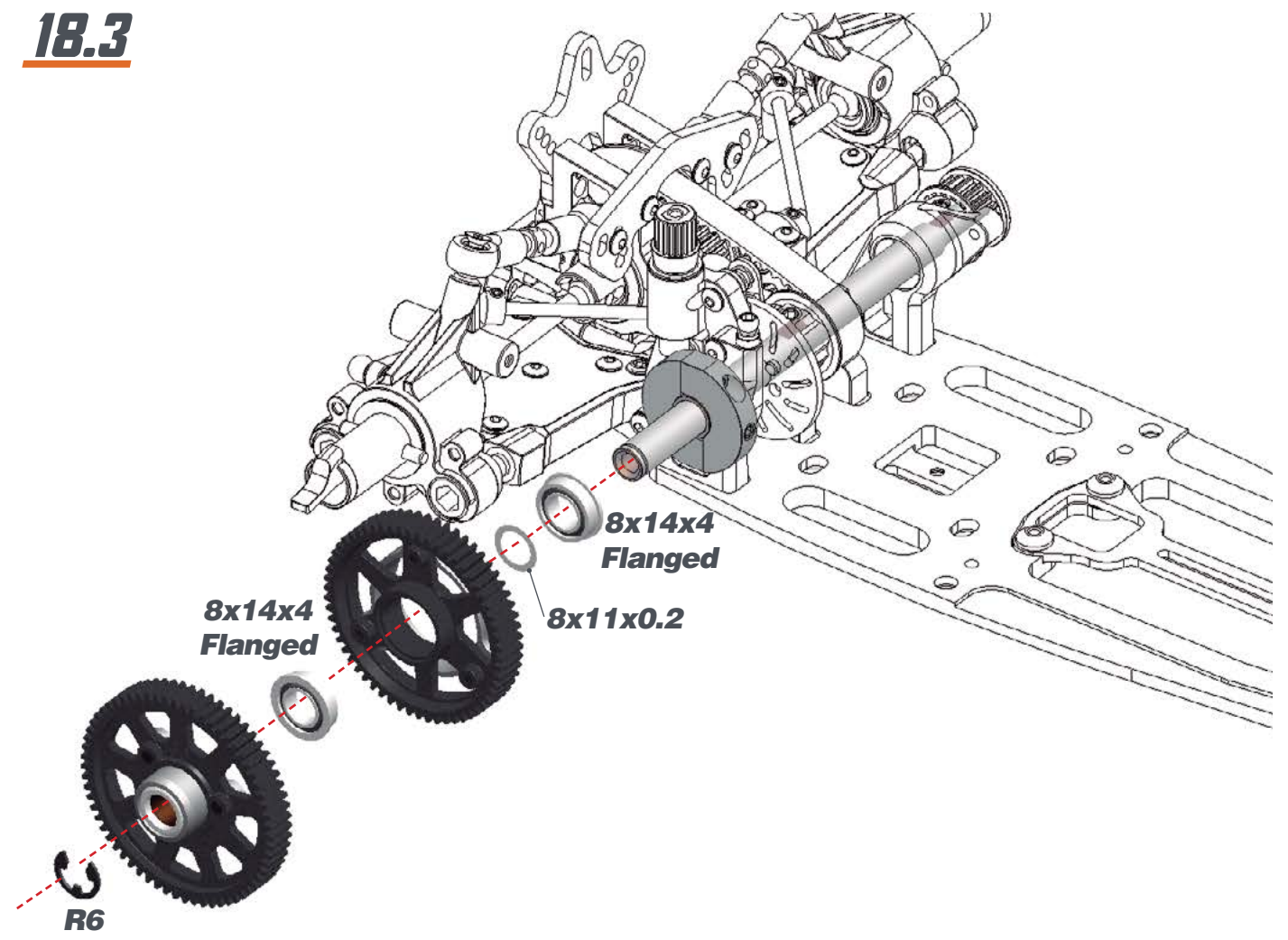

STEP 19 BAG 6

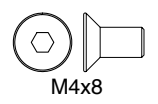
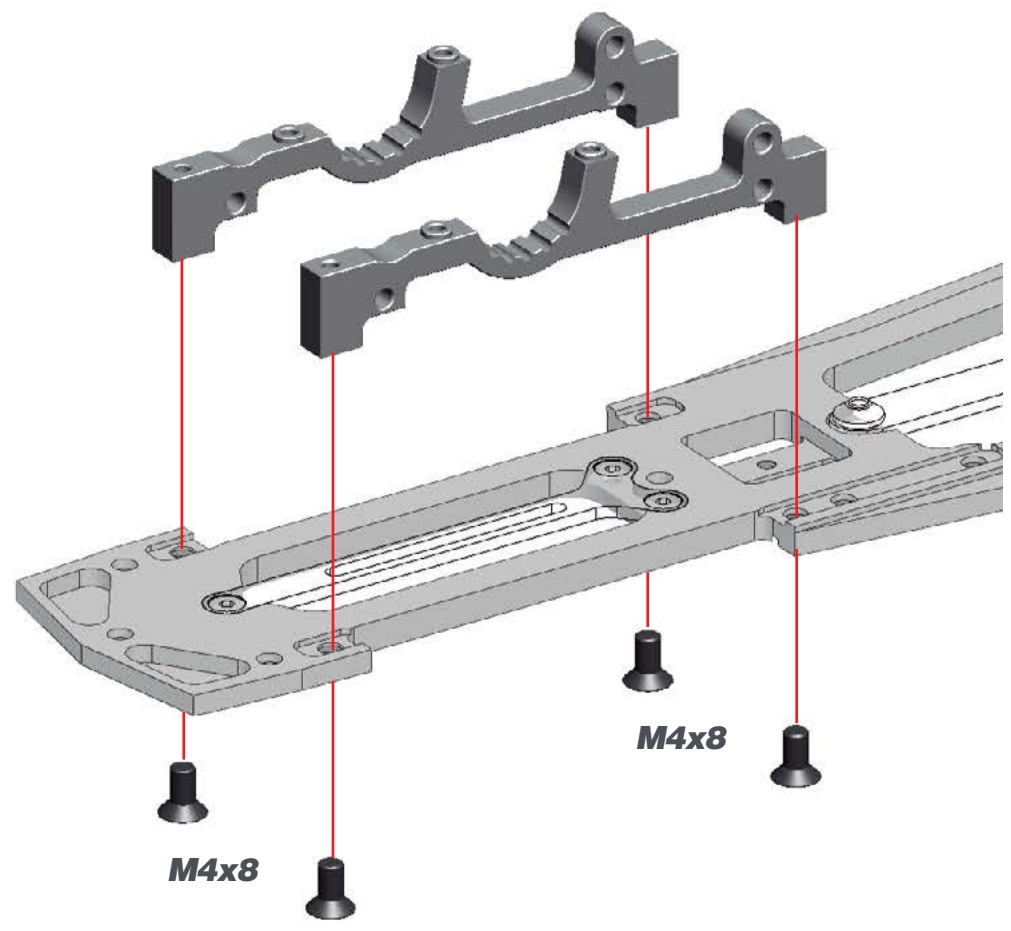

M4x8

STEP 20

20.1



20.2

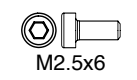

M2.5x6

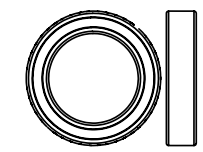

12x18x4

STEP 21

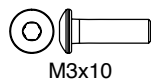
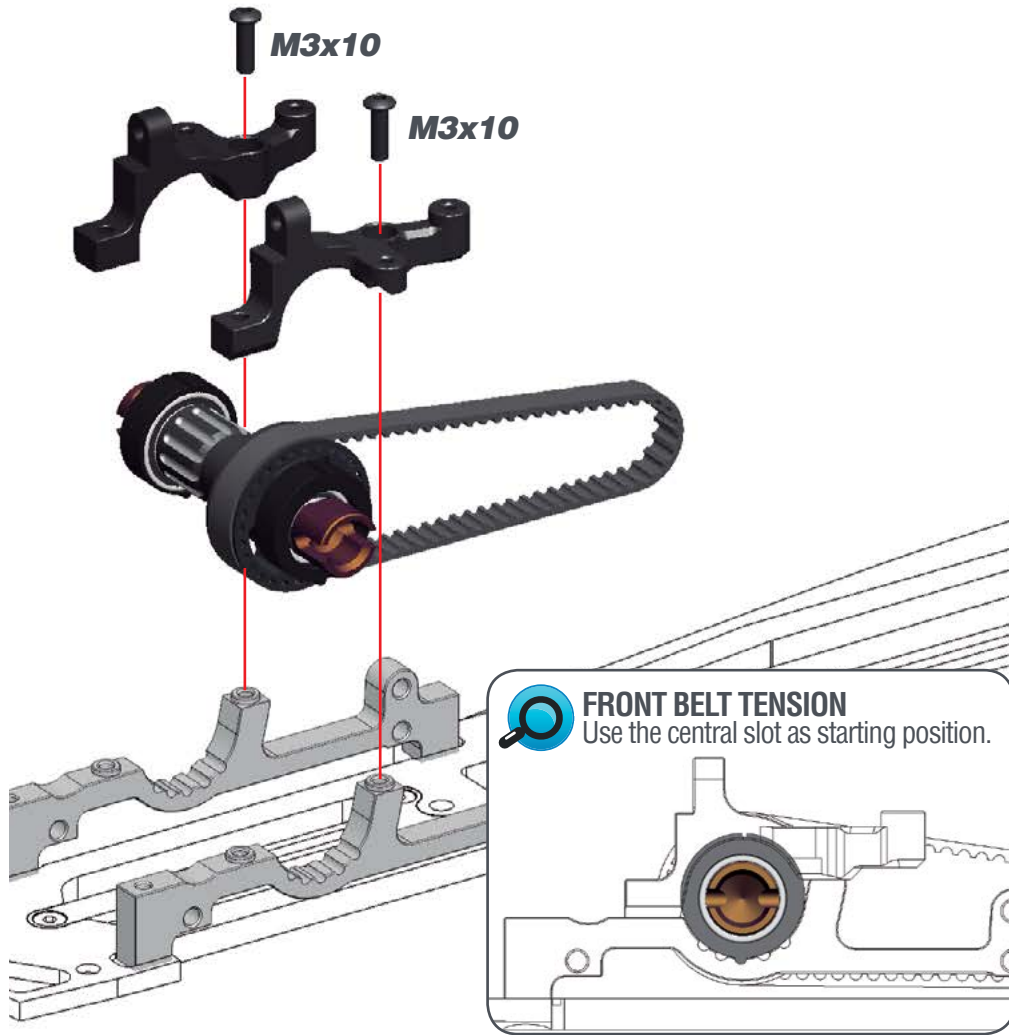

STEP 22

22.1



22.2

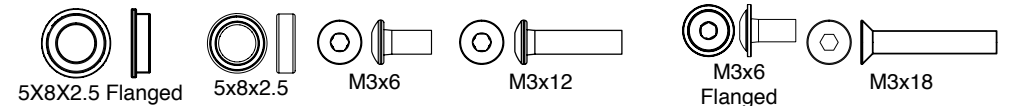
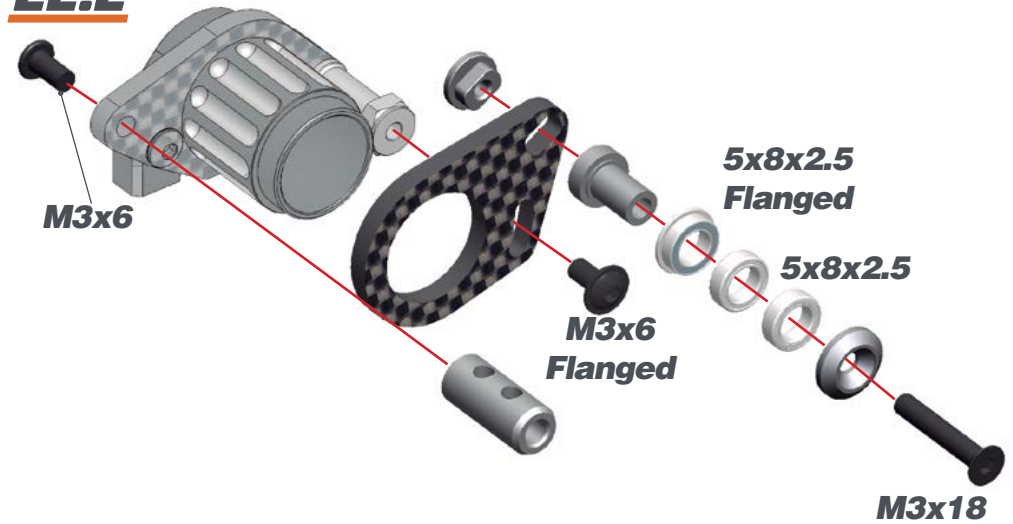

STEP 22

22.3

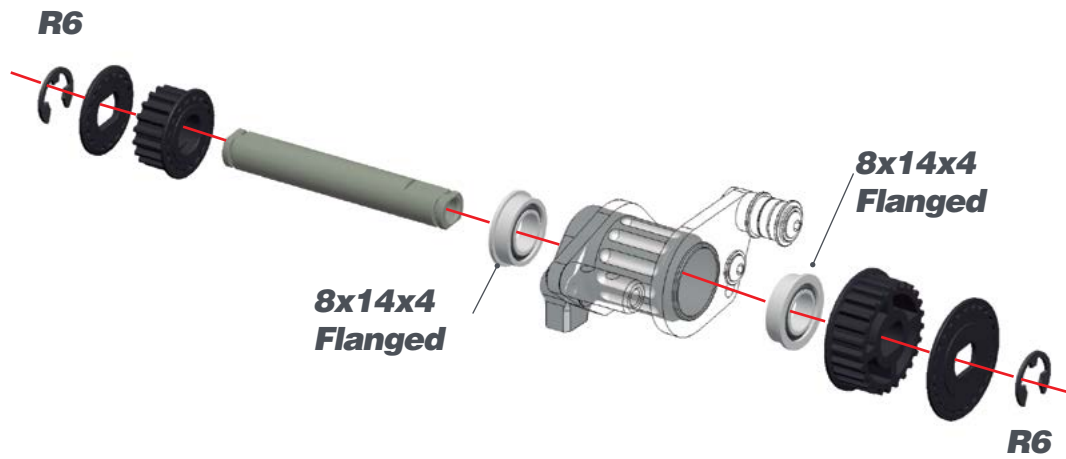

22.4

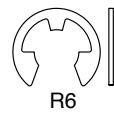
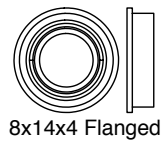
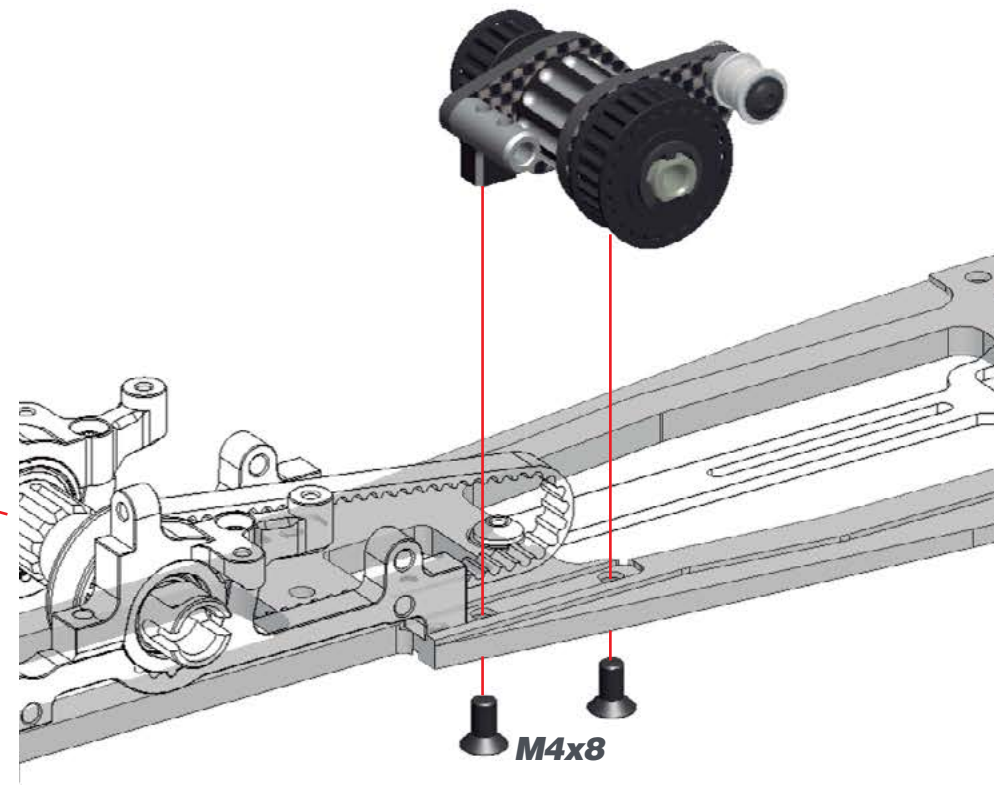

STEP 23 **BAG 7**

23.1 **L=R**



L=R FRONT ANTIROLL BAR ROD LENGTH

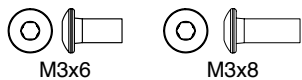
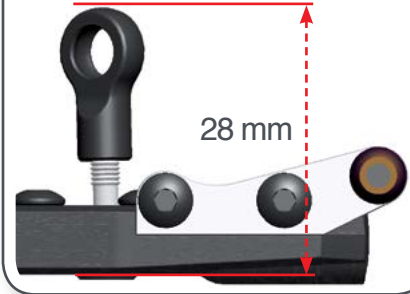

23.2

L=R

FRONT LOWER SUSPENSION AND SHOCK BRACKETS

Serpent 989 40 anniversary kit comes with the long shock bracket as standard. On the other hand, the 989 allows to move front bottom arms 3 mm in (NARROW) and out (WIDE). The default combination shows the position used at the World Championship and work best under extreme grip preventing traction rolling.

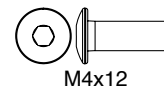
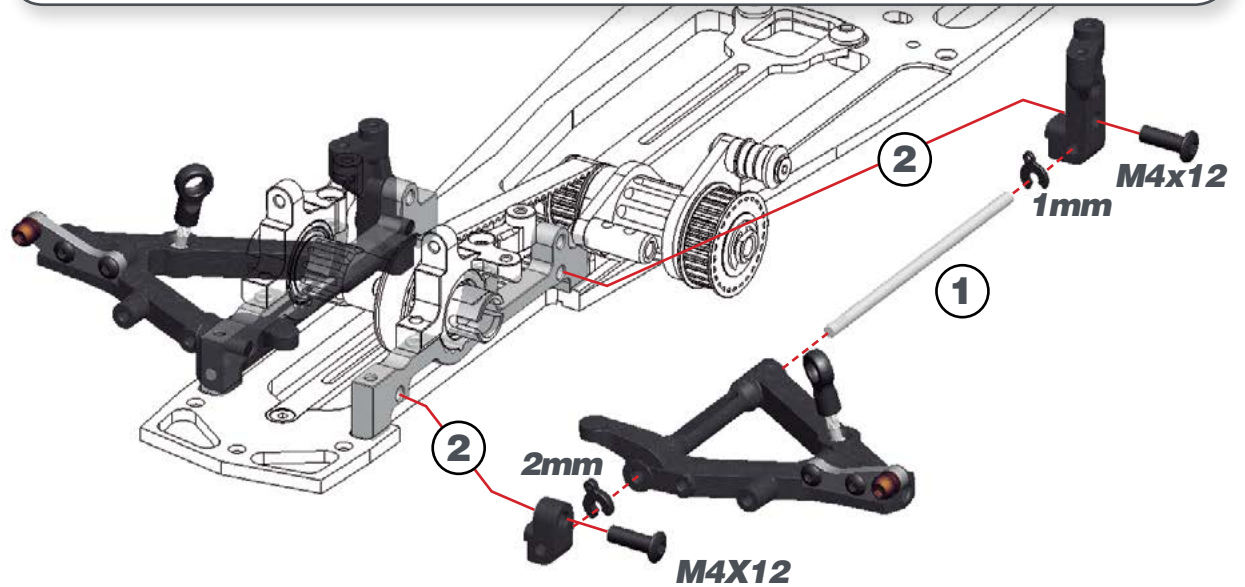
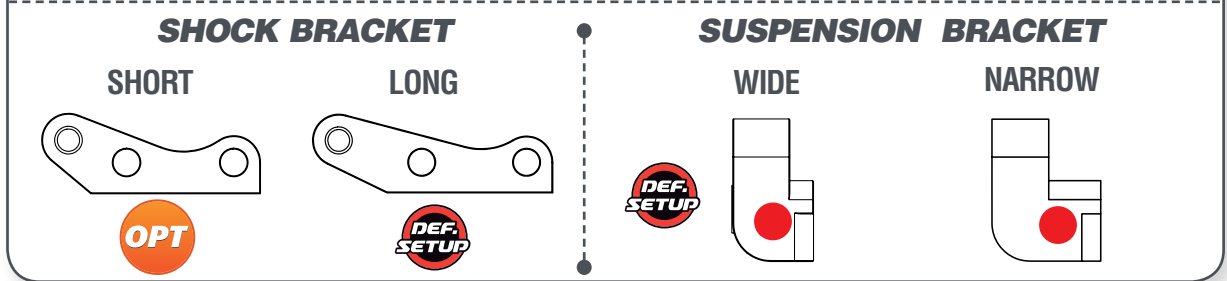

STEP 24

24.1



24.2



24.3

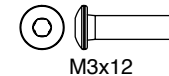
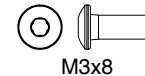
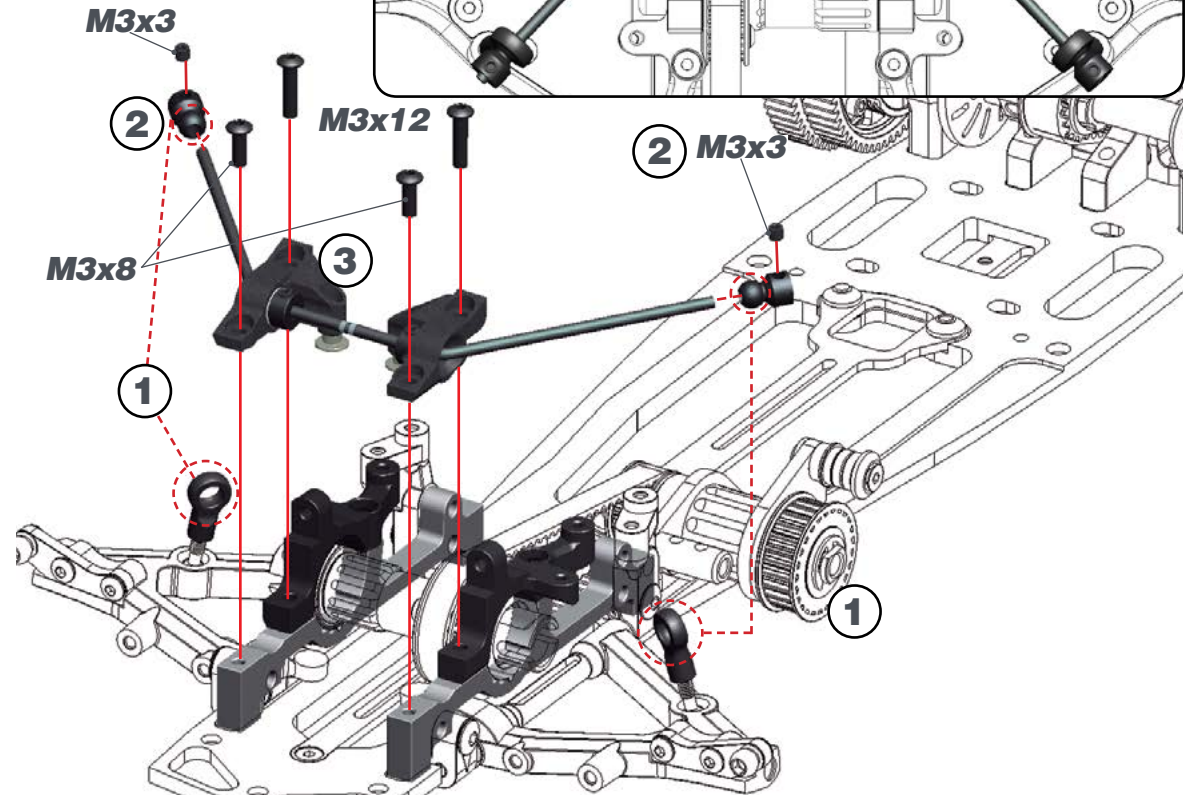
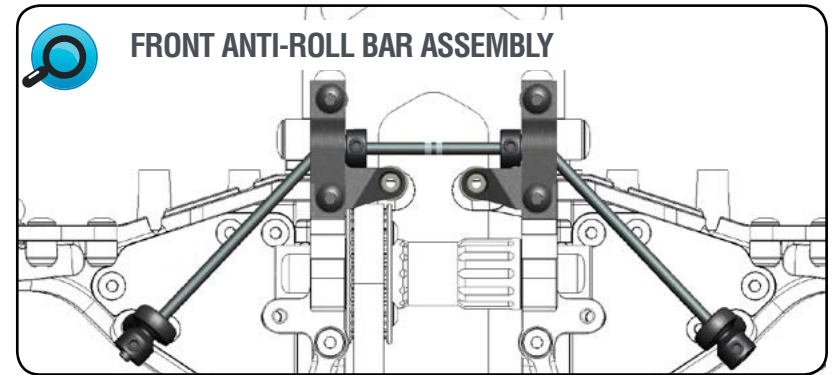

STEP 25 BAG 8

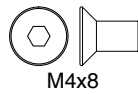
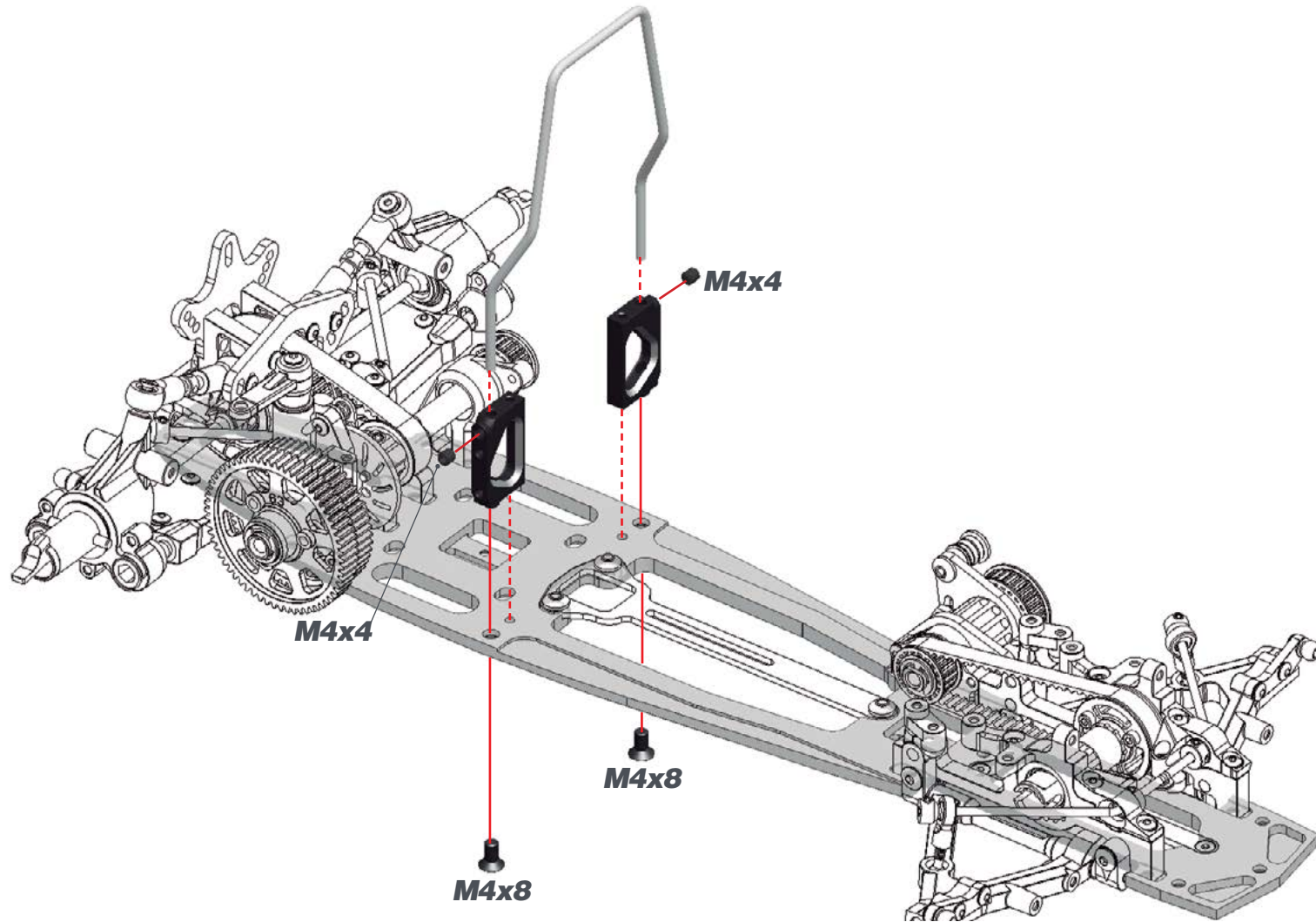

STEP 26



Preload the servo-saver-spring 1mm.

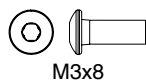
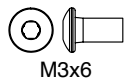
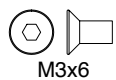
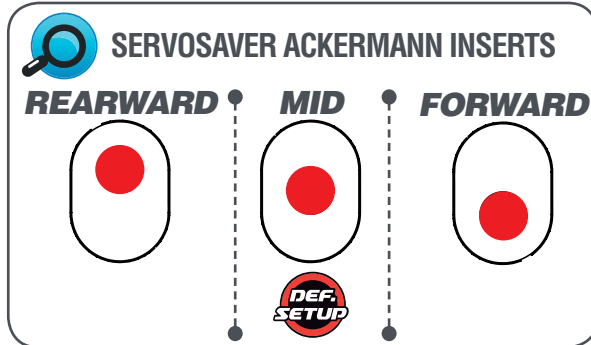

STEP 27

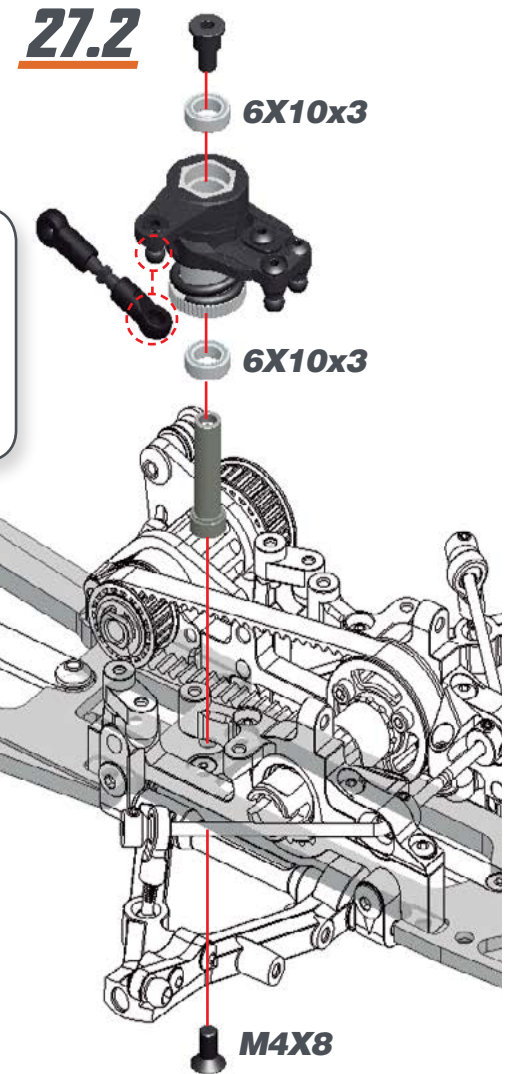

STEP 28 **BAG 9**

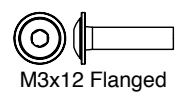
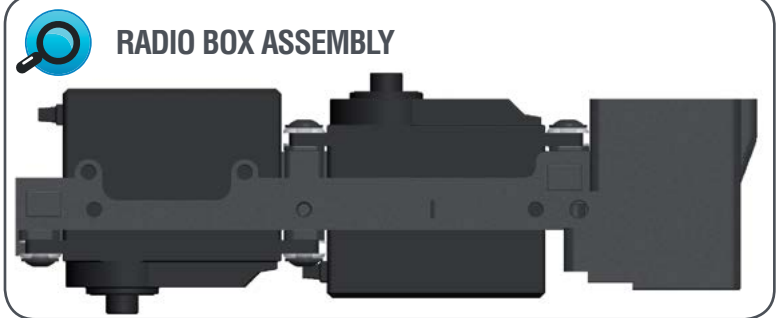
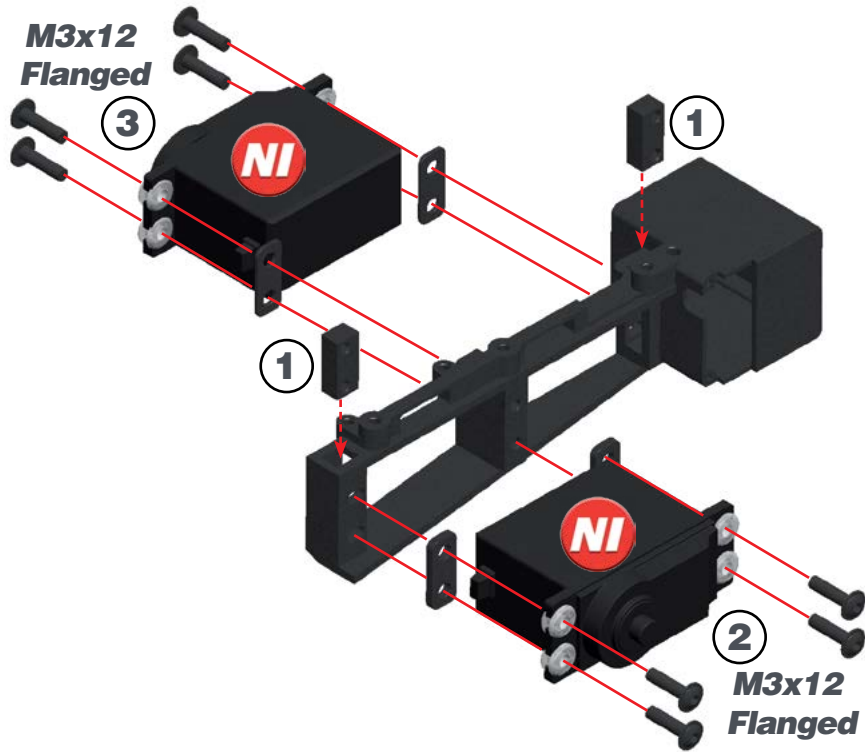

STEP 29

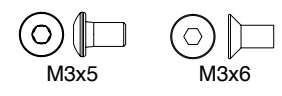
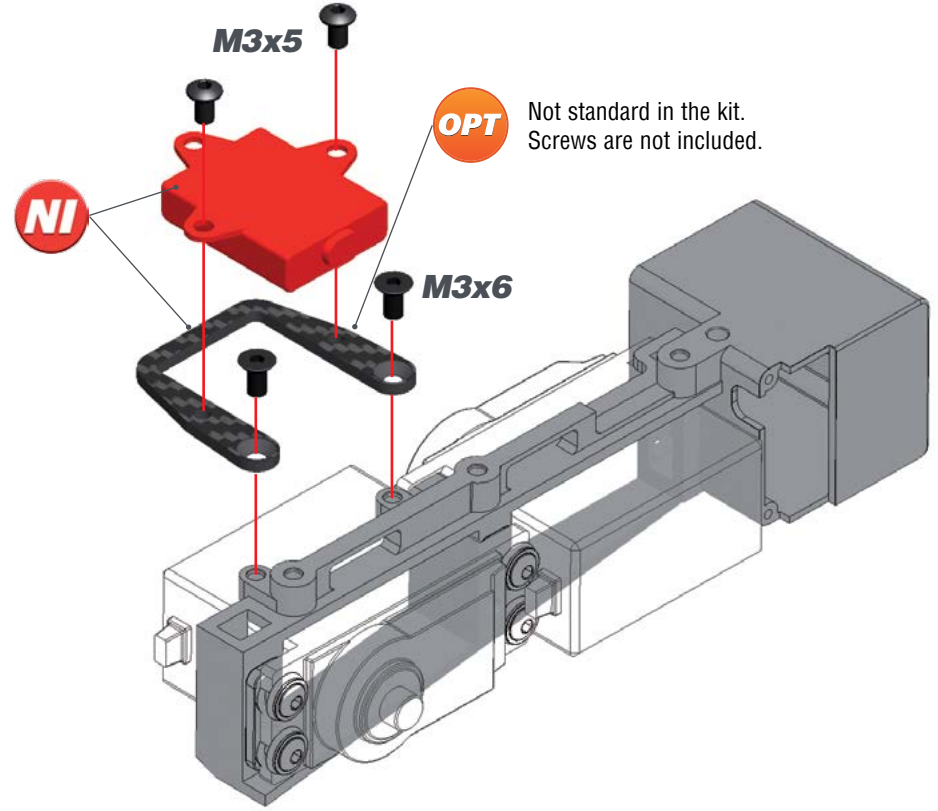

STEP 30

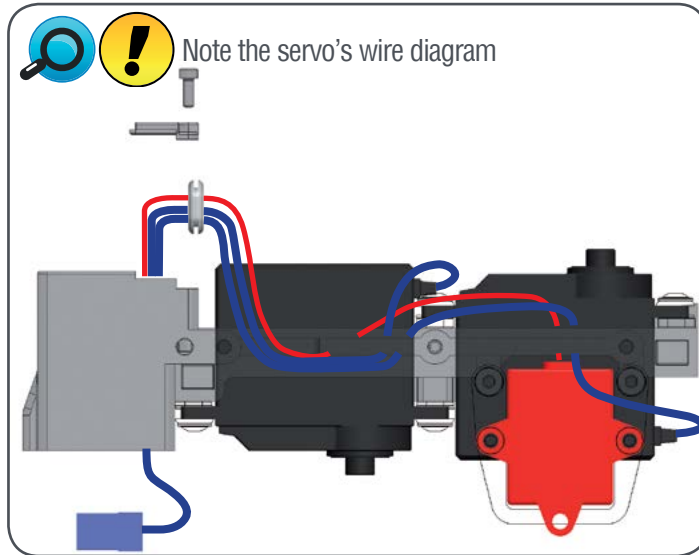
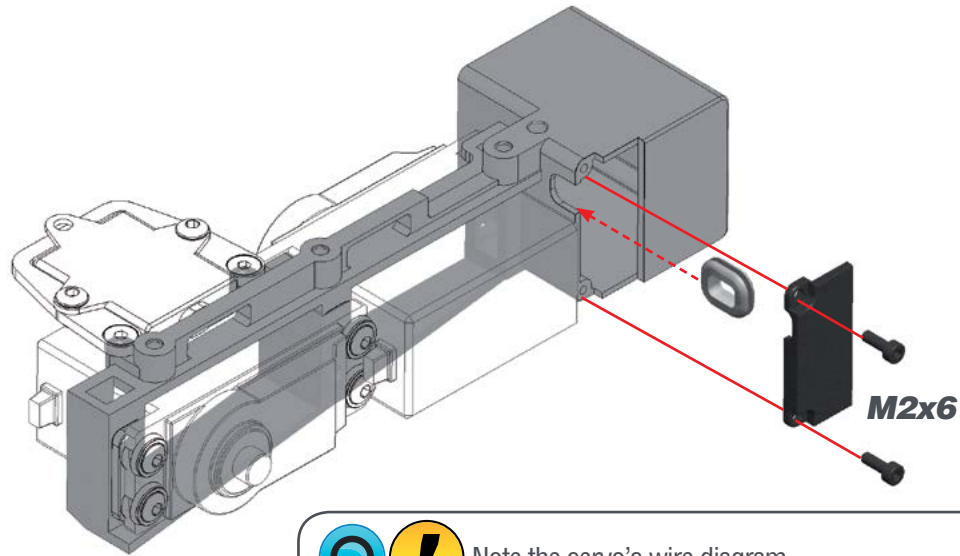

STEP 31

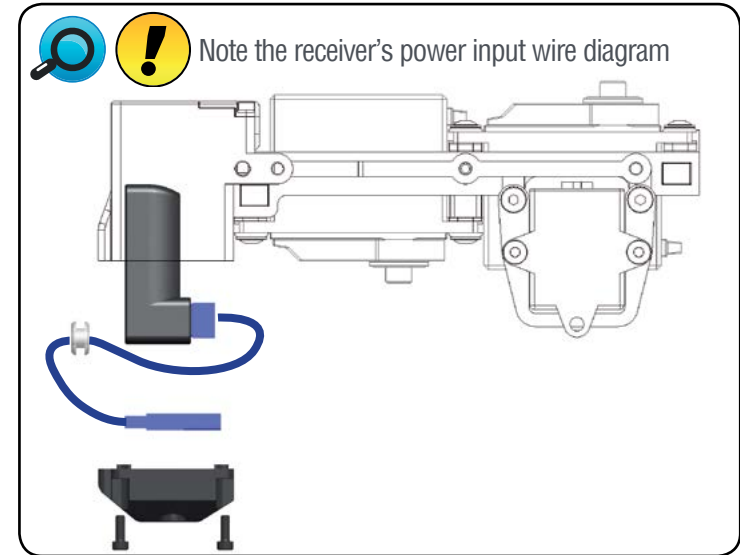
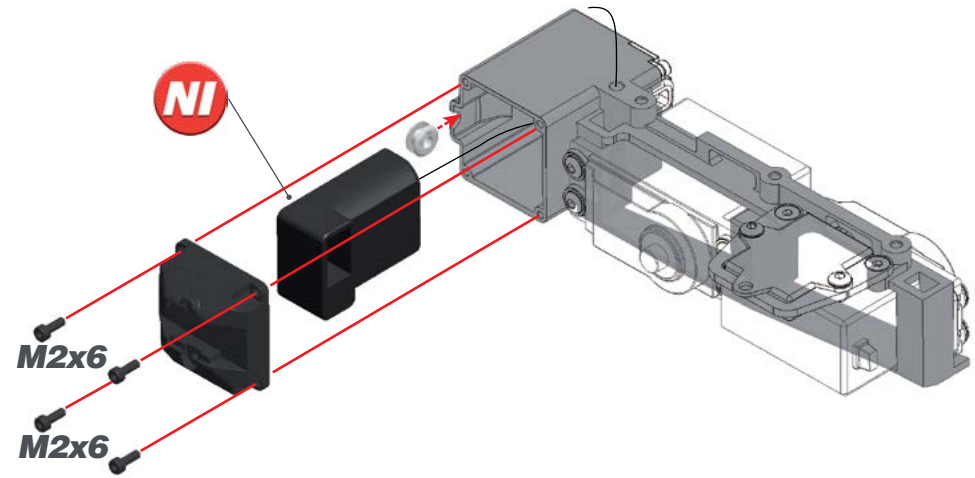

STEP 32

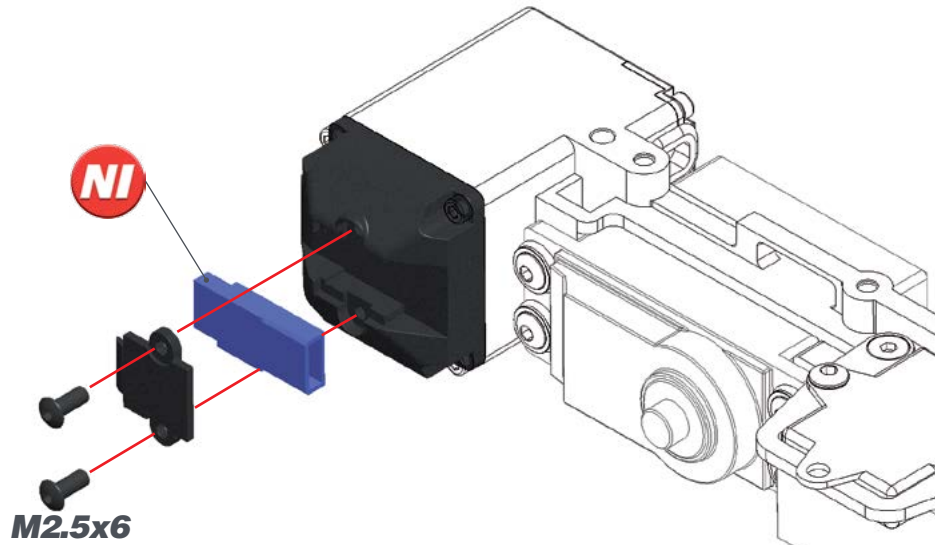

STEP 33

! Check how many teeth your servo spline has (23, 24 or 25) and use the right lever.

! Note correct pivot ball type.



! Note correct pivot ball type.

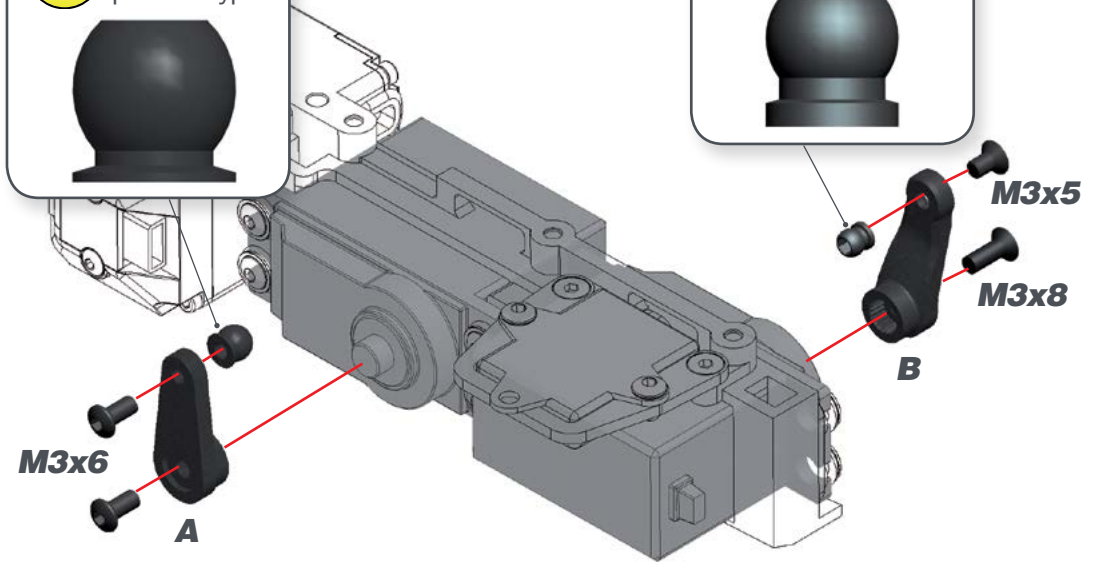

! A: Note orientation of the throttle servo lever.

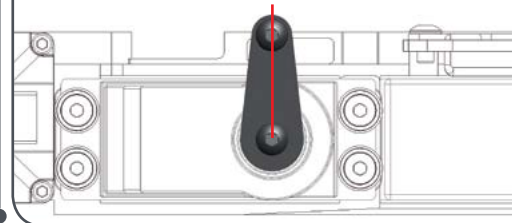

! B: Note orientation of the steering servo lever.

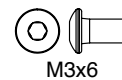
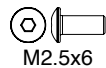
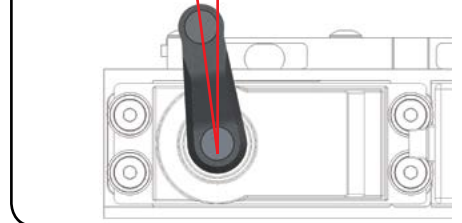

STEP 34

34.1  Check how many teeth your servo spline has (23, 24 or 25) and use the right lever.

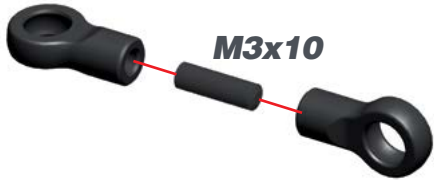

M3x10

 THROTTLE LINK LENGTH



34.2

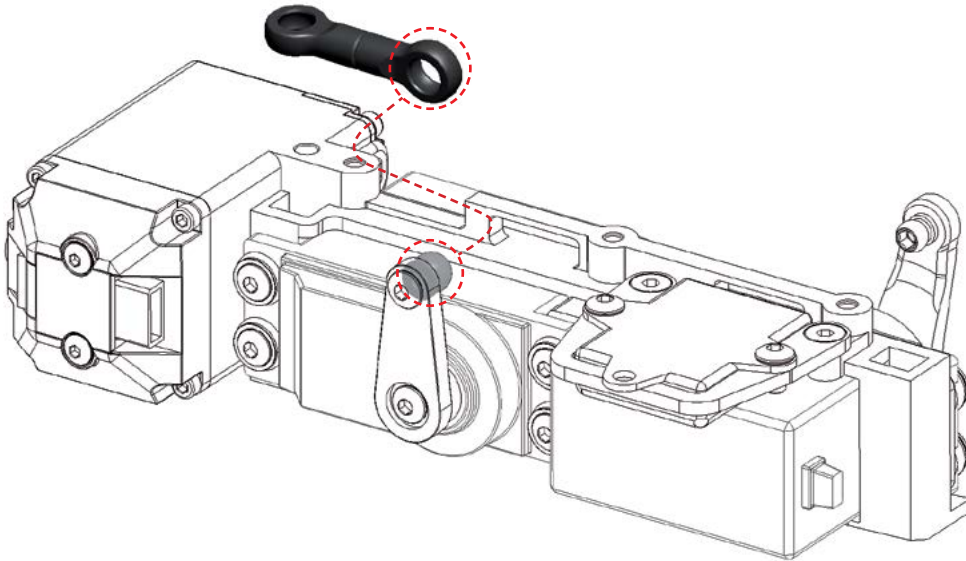

STEP 35 **BAG 10**

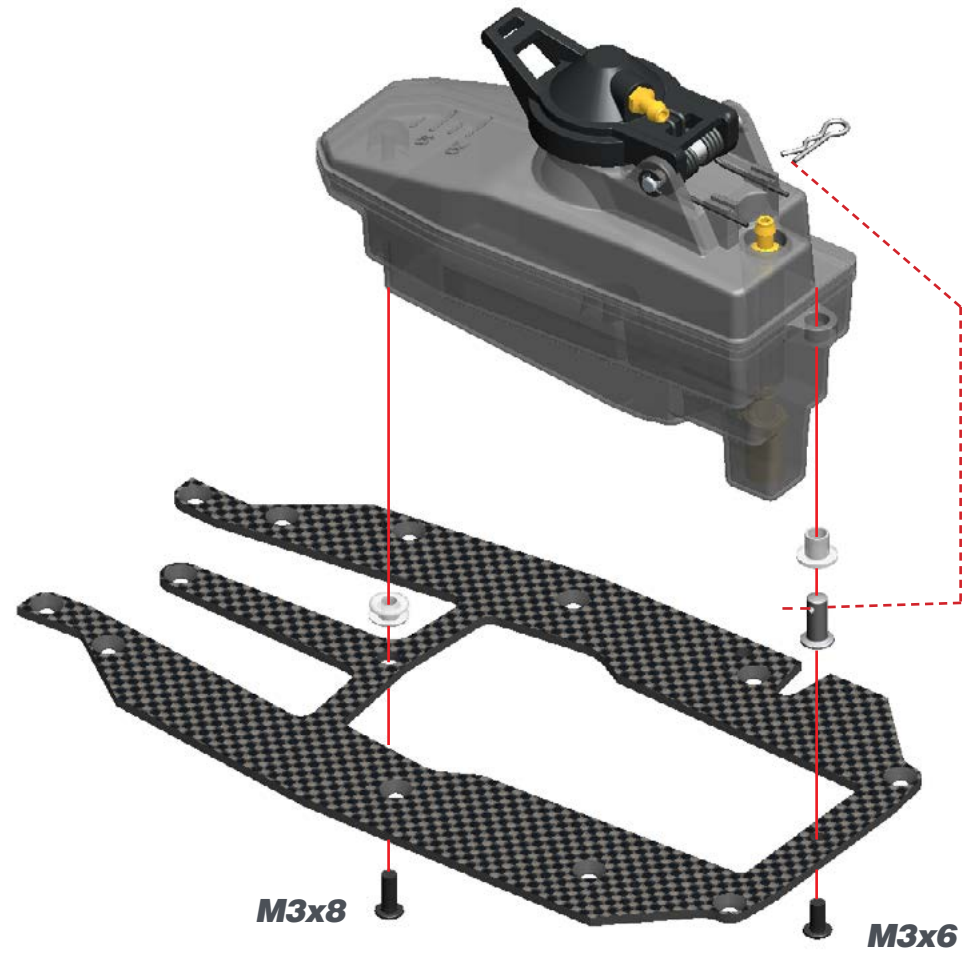

M3x8

M3x6

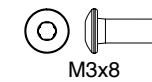
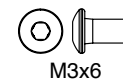

STEP 36

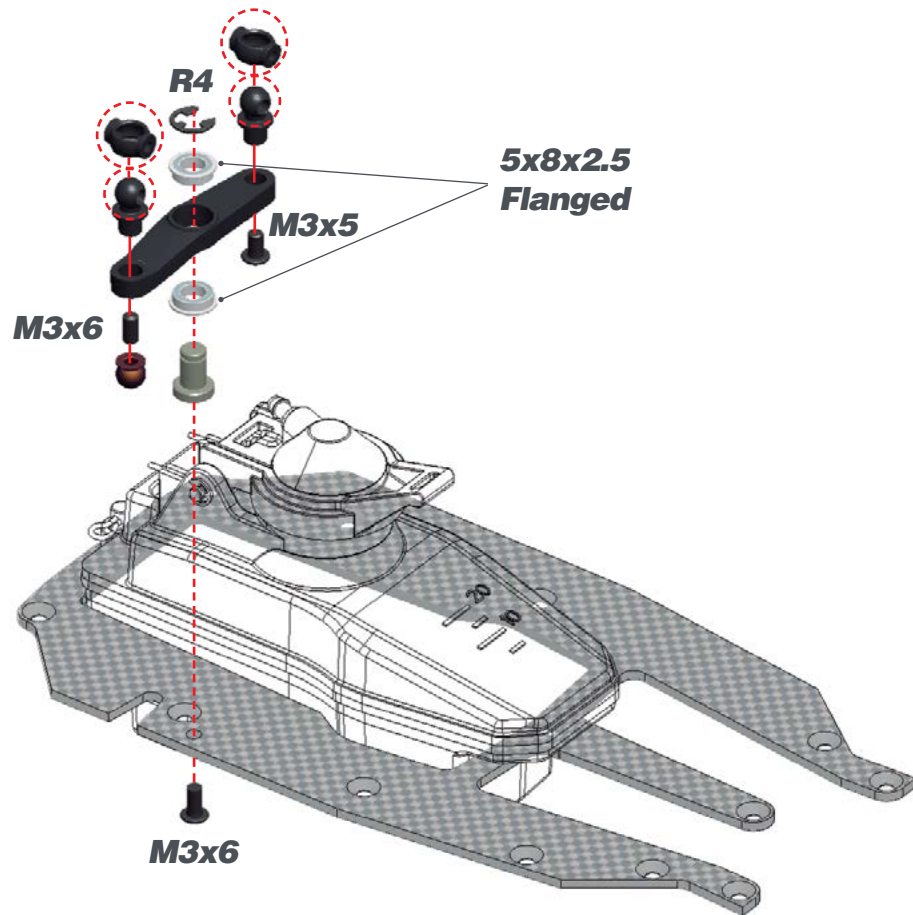

STEP 37

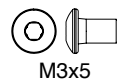
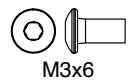
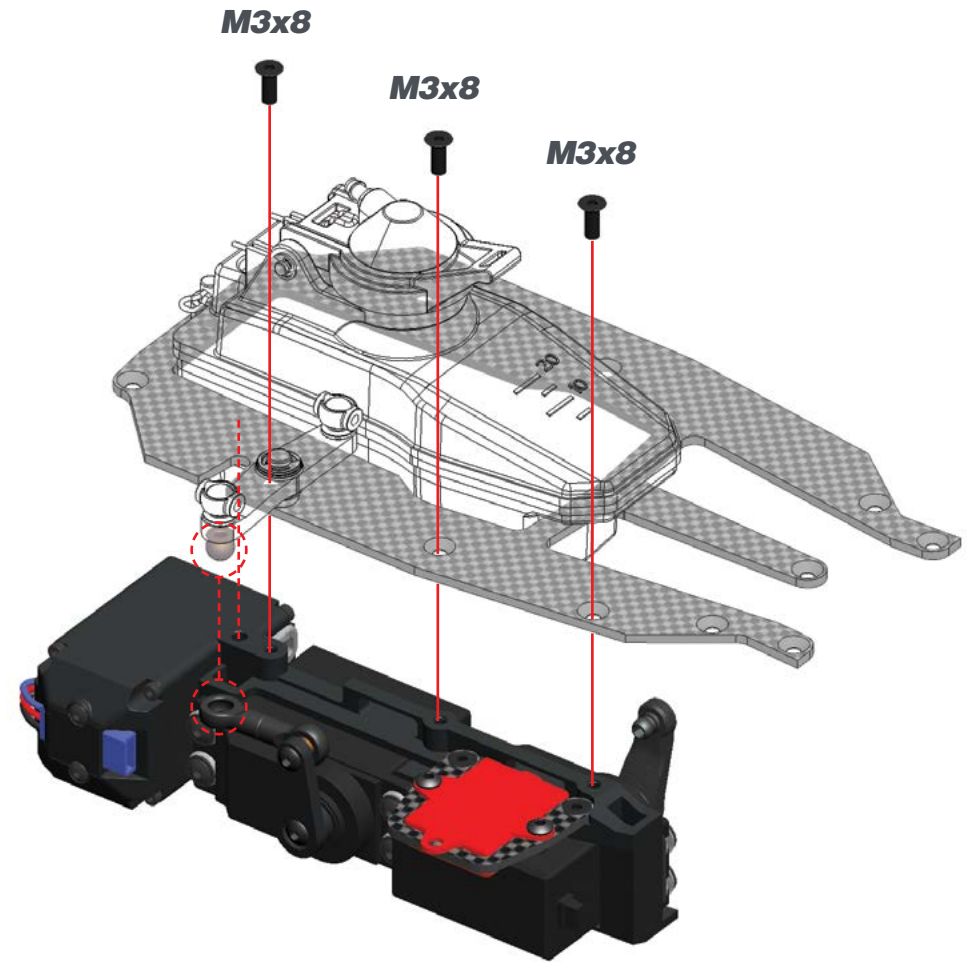

STEP 38

38.1

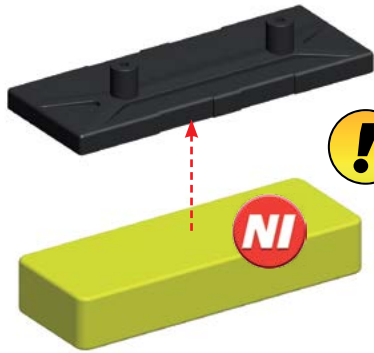

! Use tape to mount the battery to the plastic support.

38.2

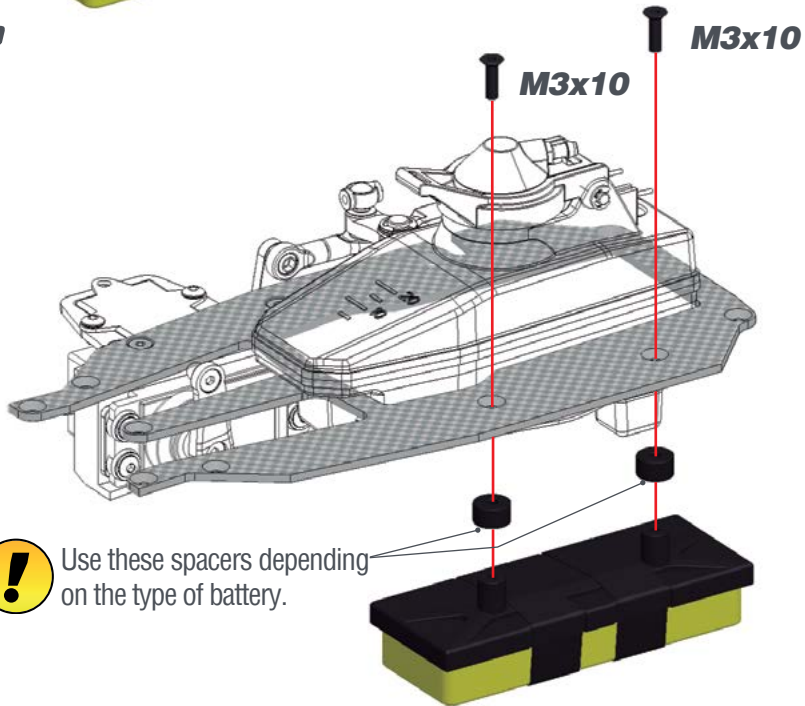

! Use these spacers depending on the type of battery.

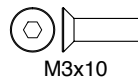

STEP 39

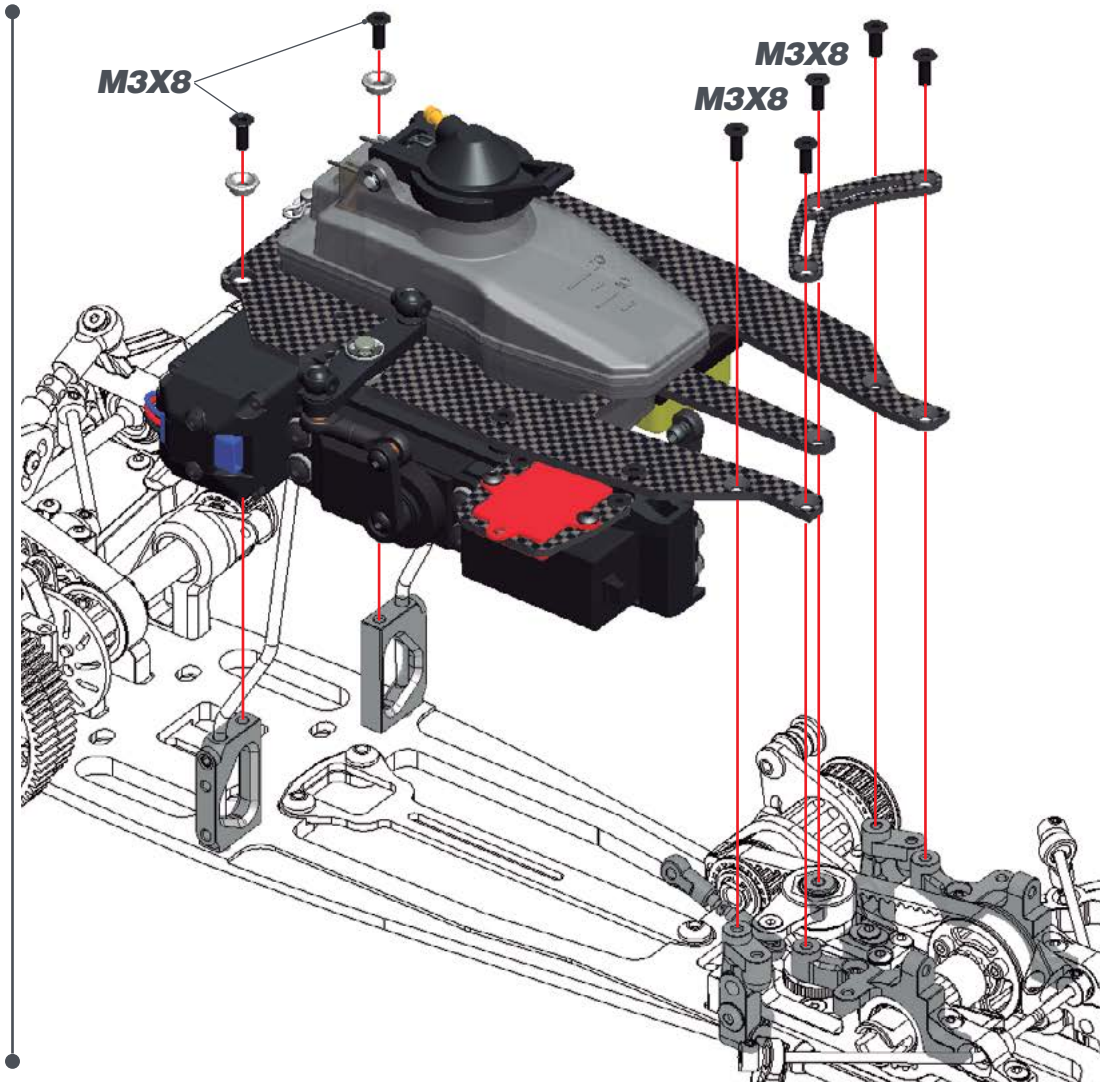

STEP 40 BAG 11

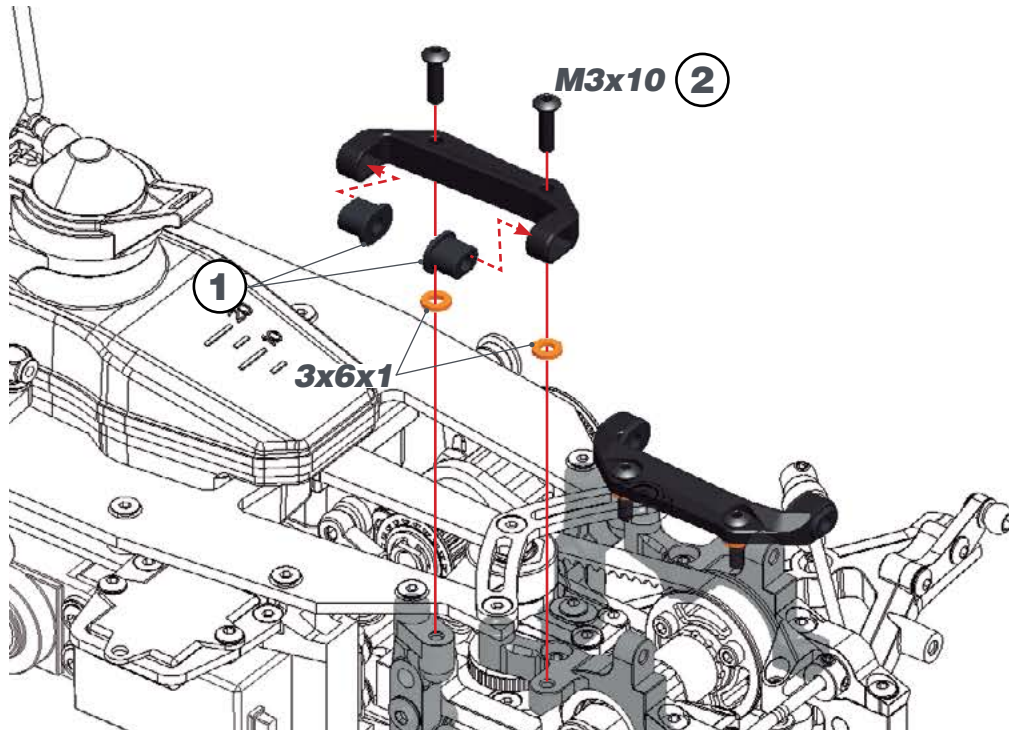

L=R FRONT SUSPENSION INSERTS CHART

INSIDE		MID		OUTSIDE	
RIGHT	LEFT	RIGHT	LEFT	RIGHT	LEFT

DEF. SETUP

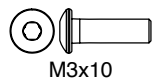

STEP 41

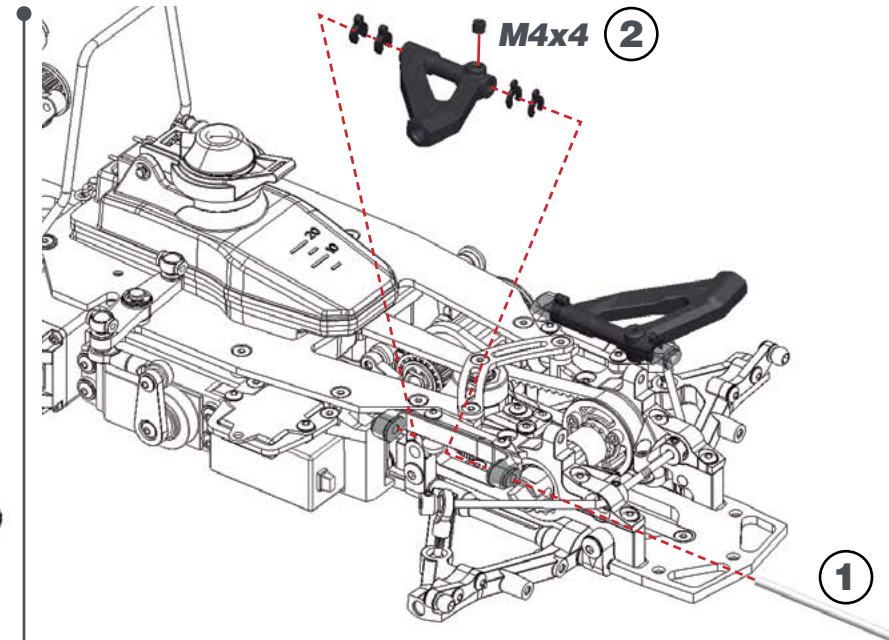

L=R FRONT CASTER DEFAULT SPACERS

DEF. SETUP

2mm 2mm 1mm 1mm



STEP 42

42.1

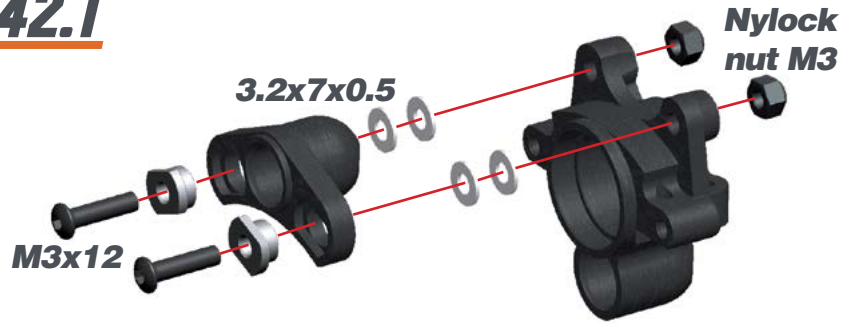

42.2

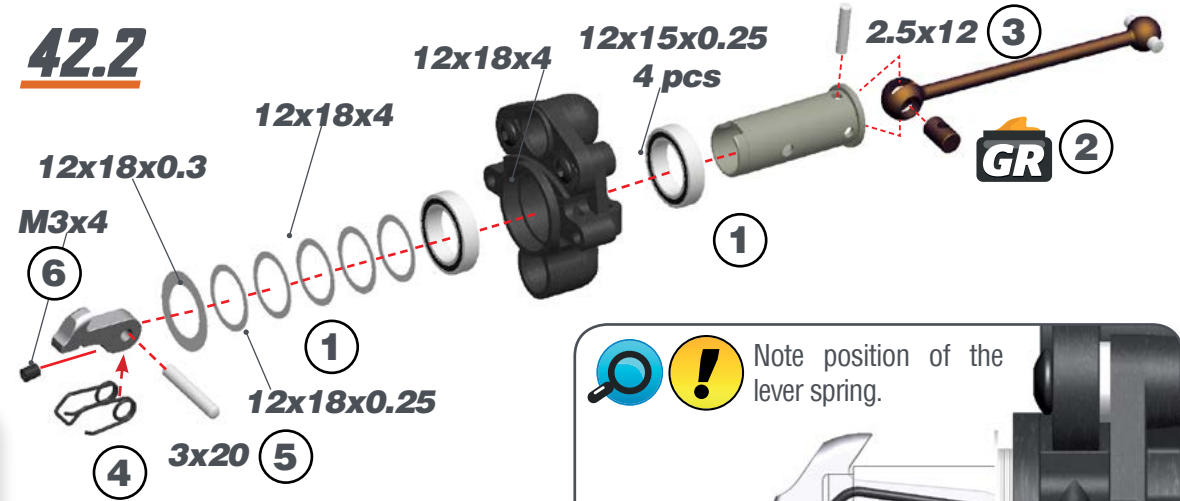

STEERING BLOCK INSERTS CHART

	LEADING	NEUTRAL DEF. SETUP	TRAILING
RIGHT			
LEFT			

42.3

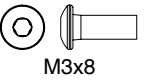
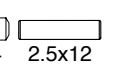
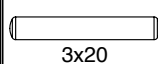
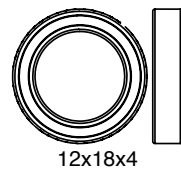
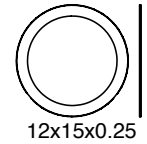
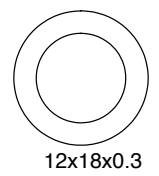
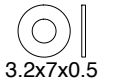
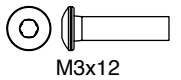
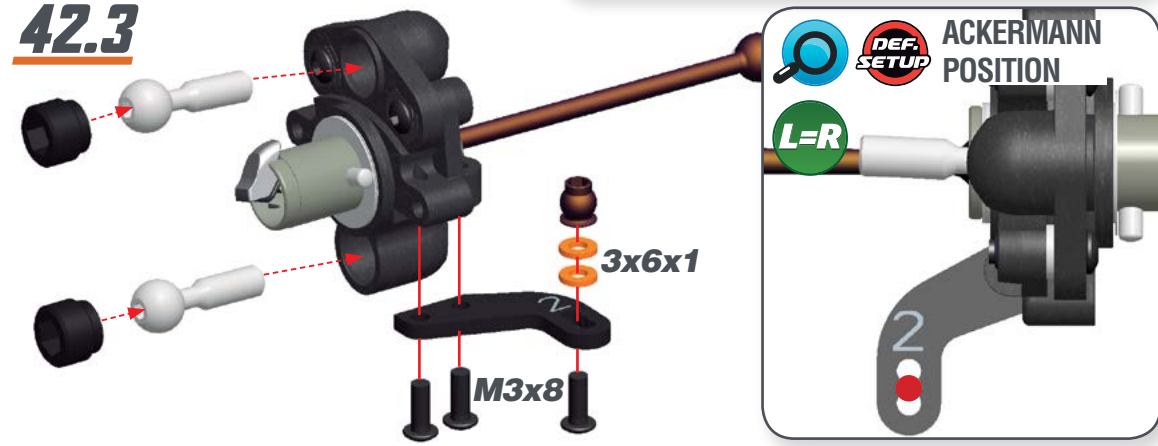

STEP 43

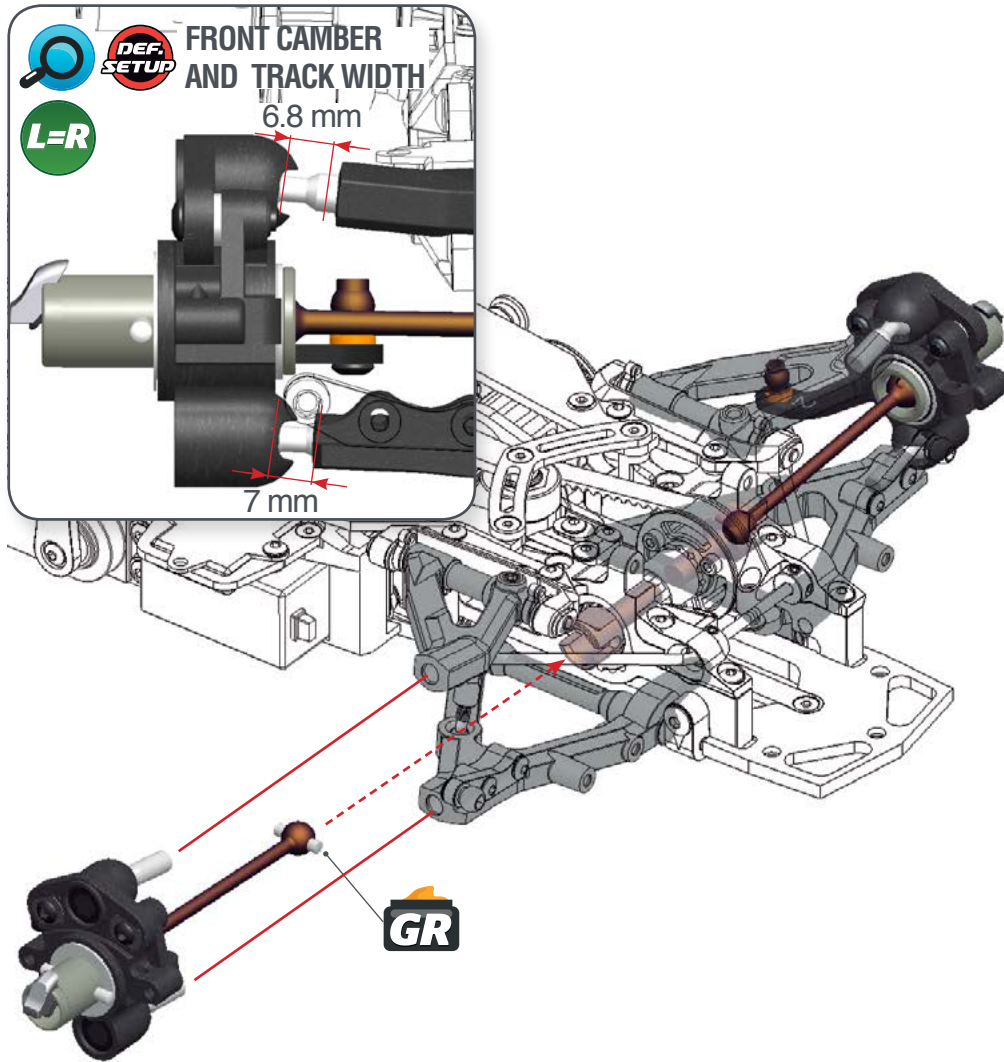

STEP 44

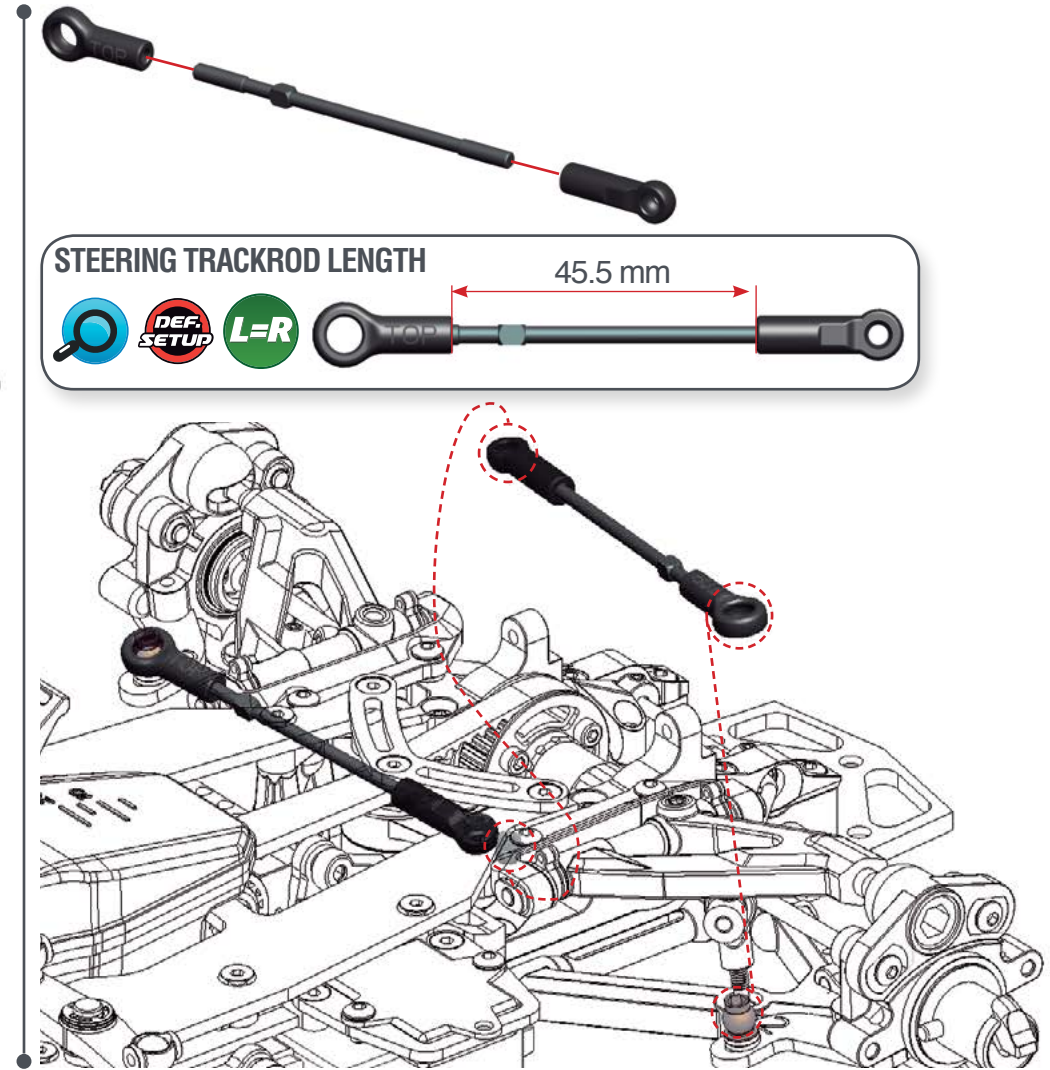

STEP 45 SHOCKS BAG

45.1

Use some silicone oil during the assembly.

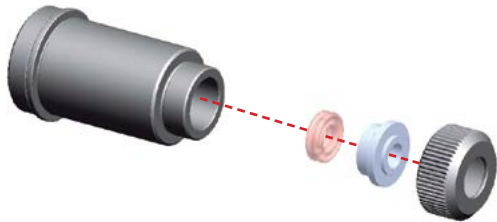

Note the correct orientation of the shock spacers.

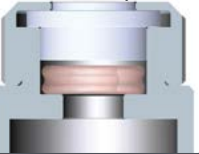

45.2

Insert the o-ring inside the spring collar.

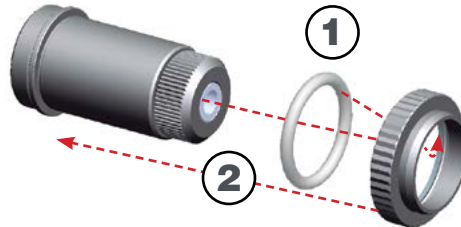

Note the correct position of the o-ring.



STEP 46

46.1



For the correct piston holes please check the default setupsheet.

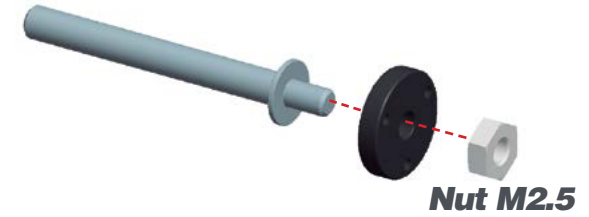

46.2



Use some silicone oil during the assembly.

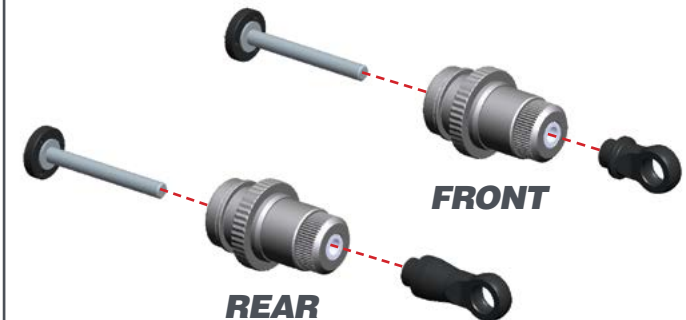

Nut M2.5

STEP 47

47.1

Push the shock top and the membrane into the shock cap.



47.2

1- Fill up with silicone oil fully using the silicone oil supplied in the kit. For the correct cst value please check the default setupsheet.

2- Extend the shockrod fully

3- Move the shockrod slowly up and down to let ALL air bubbles escape.

4- Close top only 3/4.



47.3

1-Bleed: push the shockrod all the way in slowly, to allow excessive oil to escape.

2- Close the shock cap completely.



SHOCKS LENGTH:

Measure the shock length fully extended.

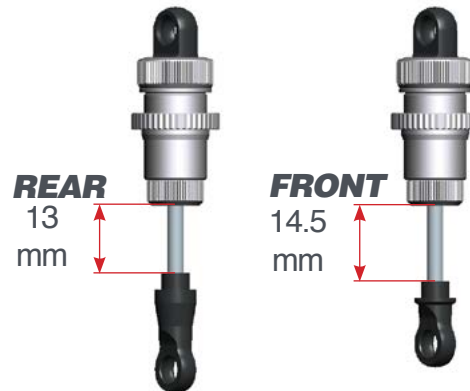

STEP 48

Assemble the spring and spring-cup (align correctly) to complete the shock.

FRONT

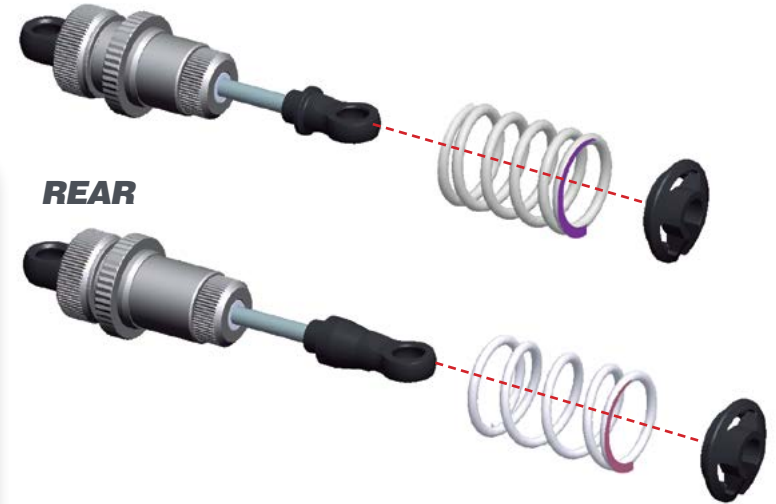

REAR

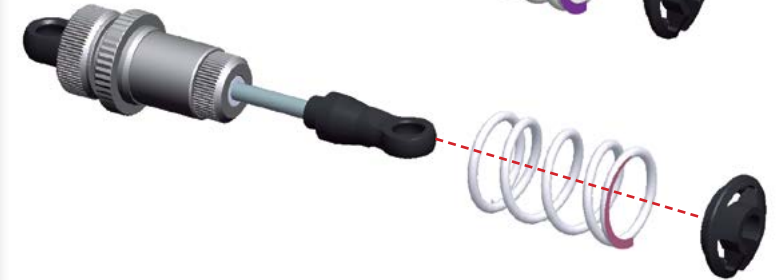

STEP 50 **BAG 12**

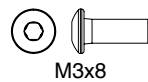
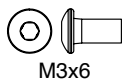
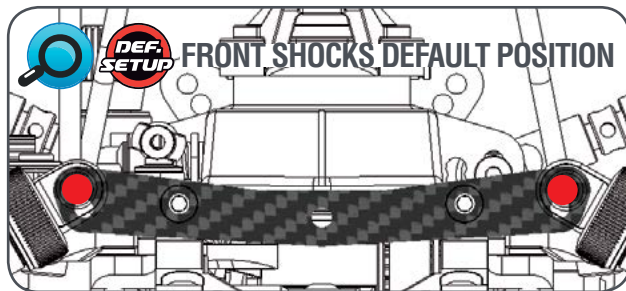
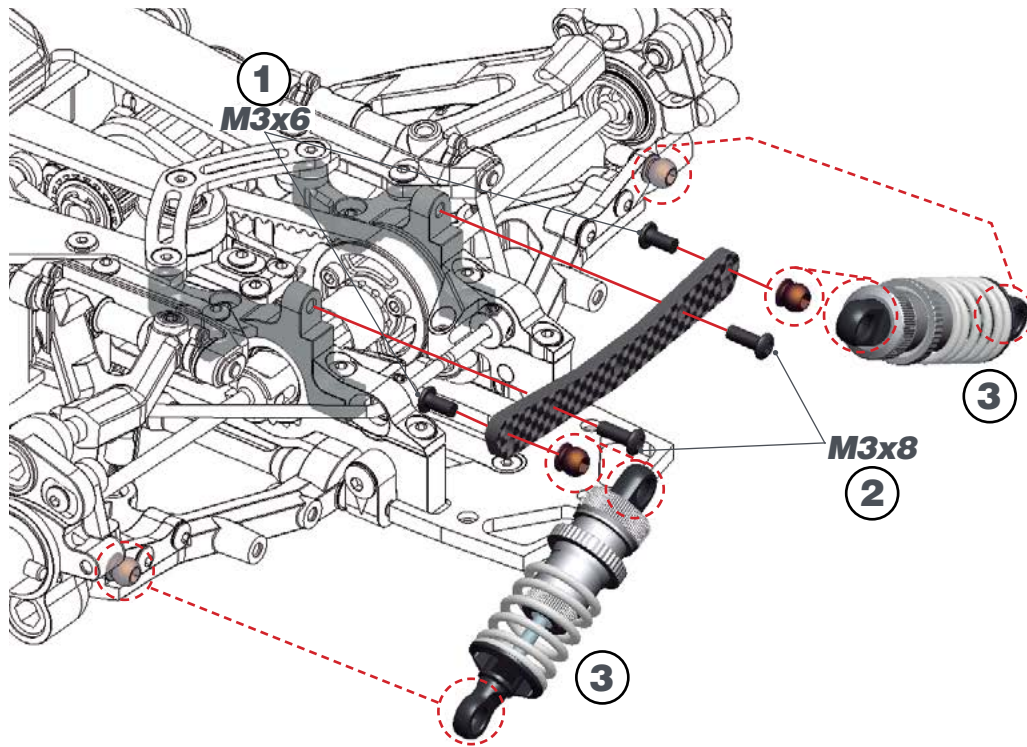

STEP 51

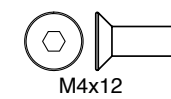
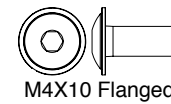
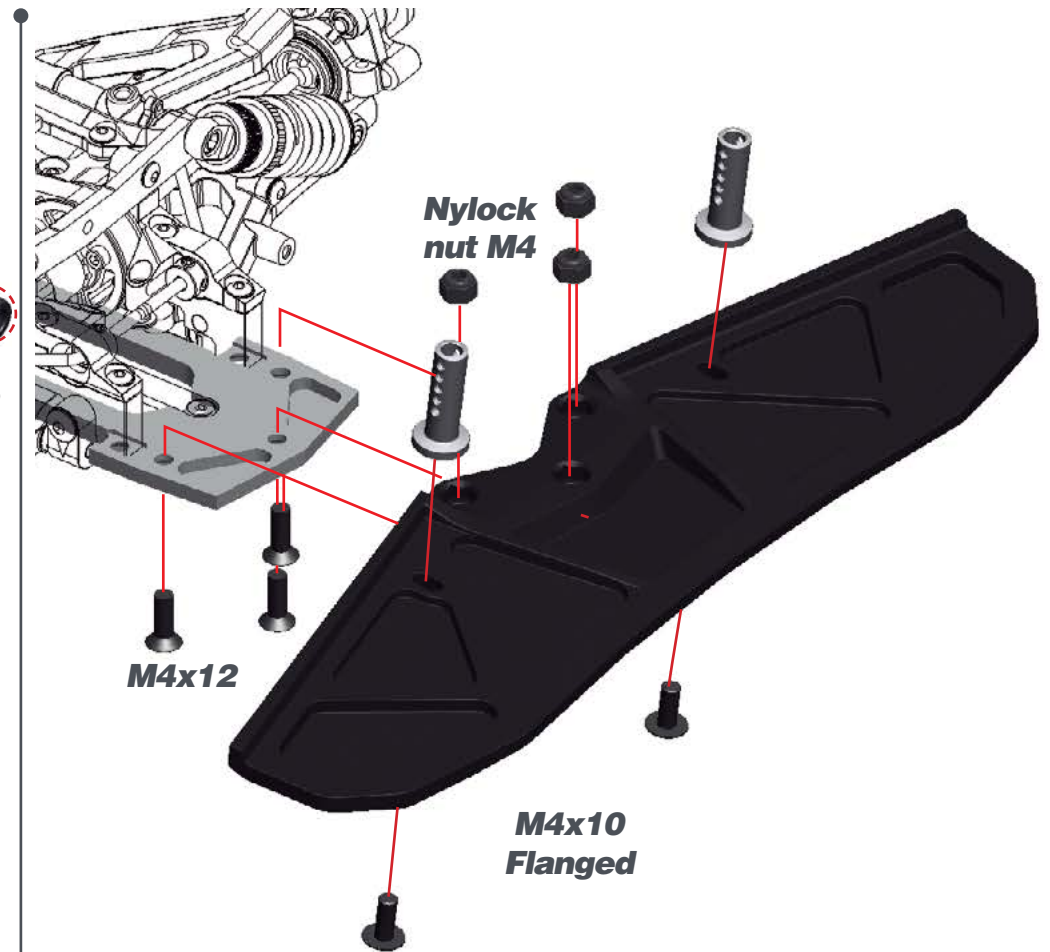

STEP 52

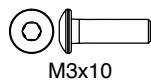
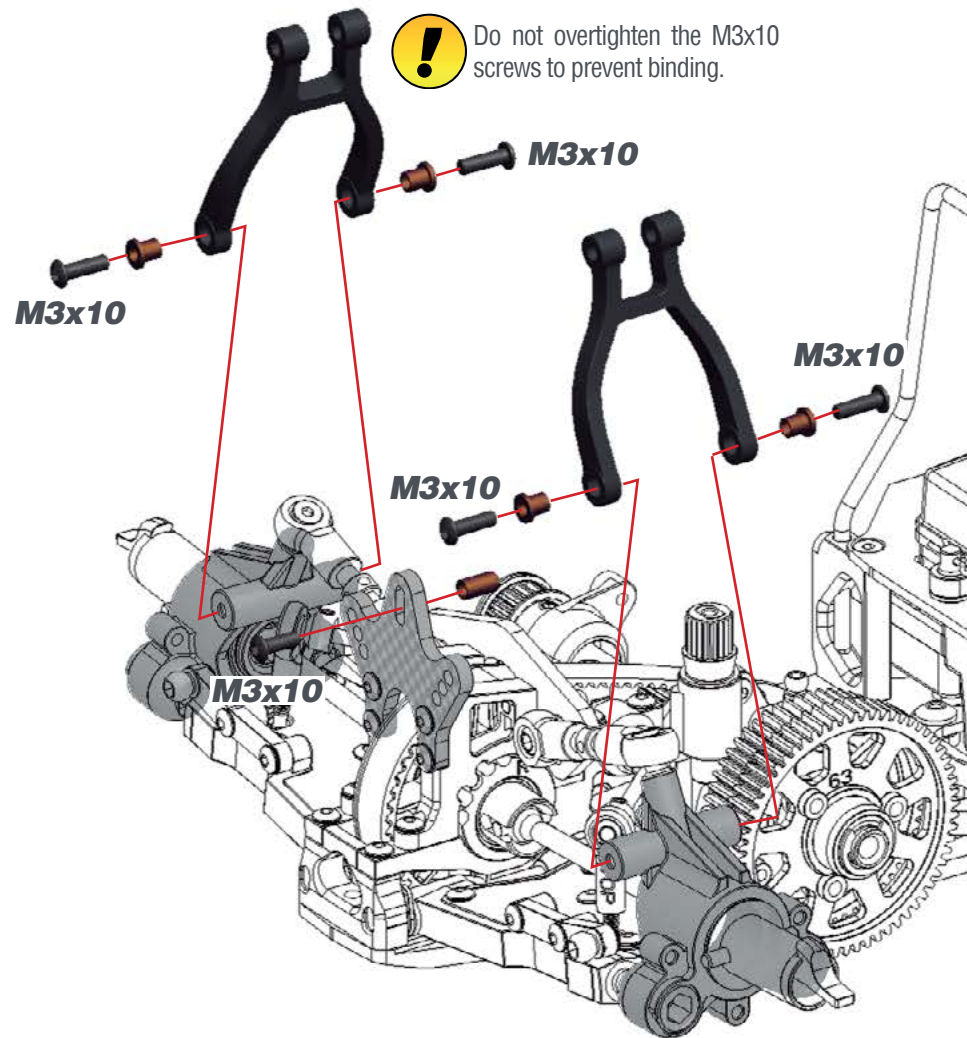

STEP 53

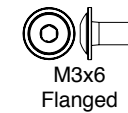
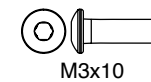
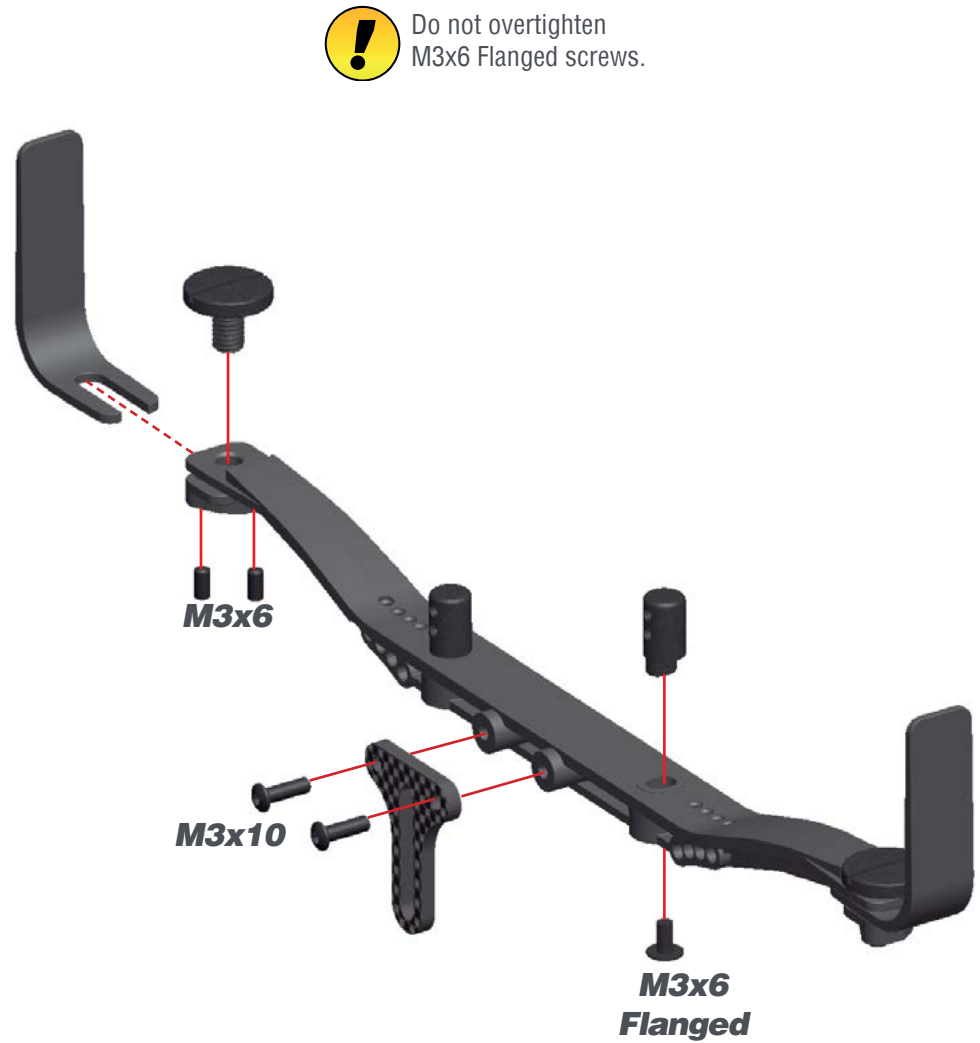

STEP 54

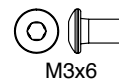
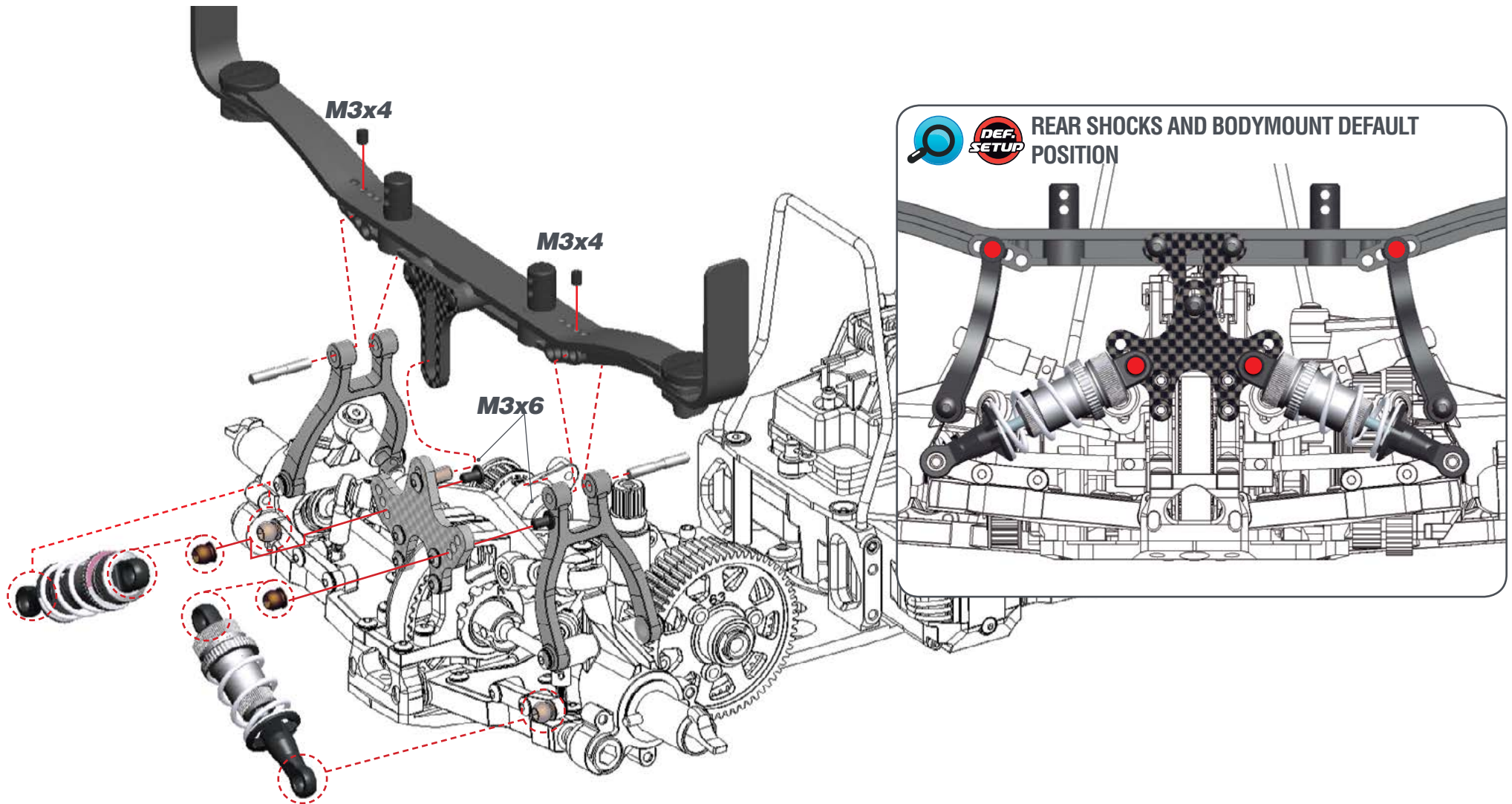

STEP 55 CLUTCH BAG

55.1

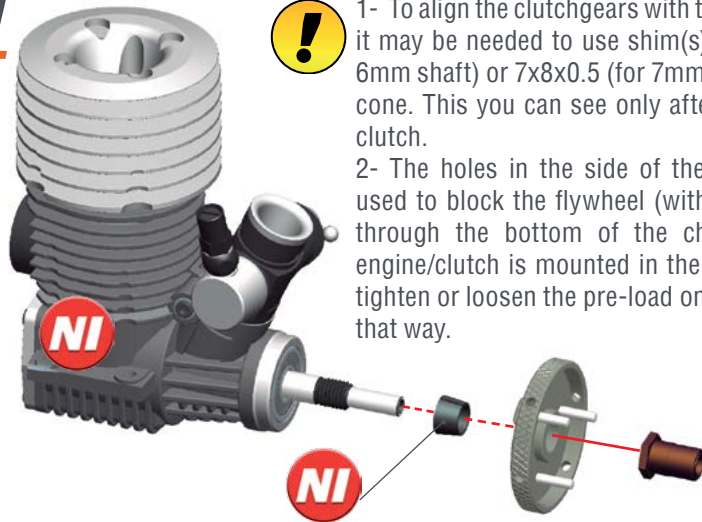

1- To align the clutchgears with the 2-speed gears, it may be needed to use shim(s) 6x8x0.5mm (for 6mm shaft) or 7x8x0.5 (for 7mm shaft) behind the cone. This you can see only after assembling the clutch.

2- The holes in the side of the flywheel can be used to block the flywheel (with short allen tool) through the bottom of the chassis, when the engine/clutch is mounted in the car. It's easier to tighten or loosen the pre-load on the clutch spring that way.



55.2

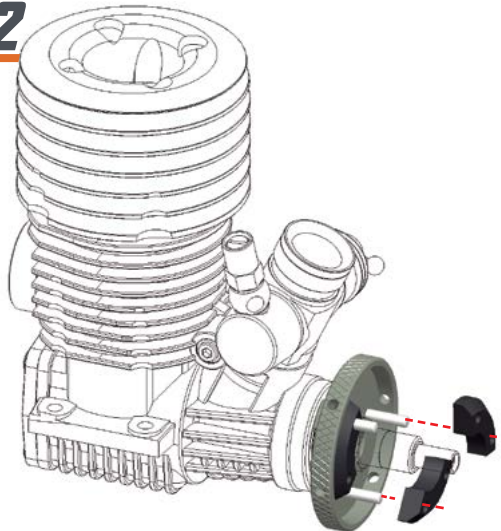

Note the orientation of the flyweights. Use the right hole for having a more aggressive clutch

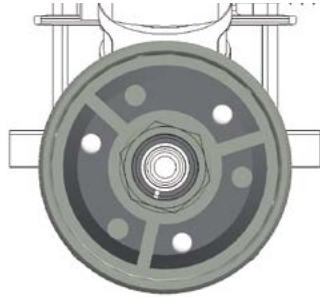

56.1

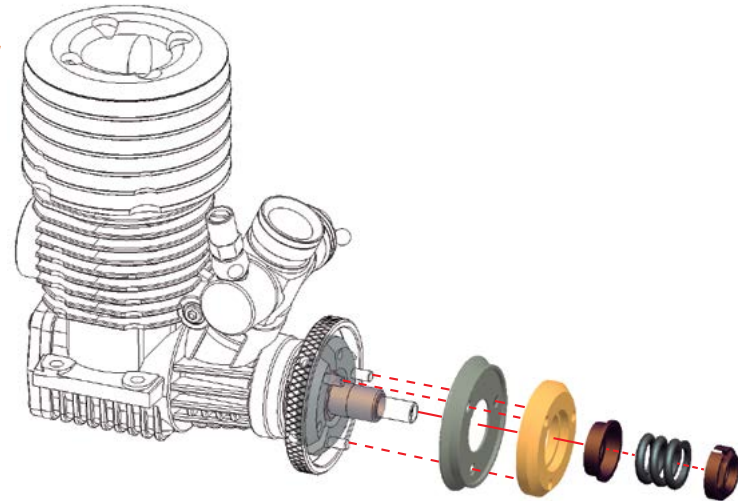

56.2



For adjusting the default clutch spring tension:

- 1- Screw in the adjusting nut all the way.
- 2- Unscrew it one and a half turns.
- 3- Fine tune the setup of your clutch on the track according to your driving style, track and weather conditions.

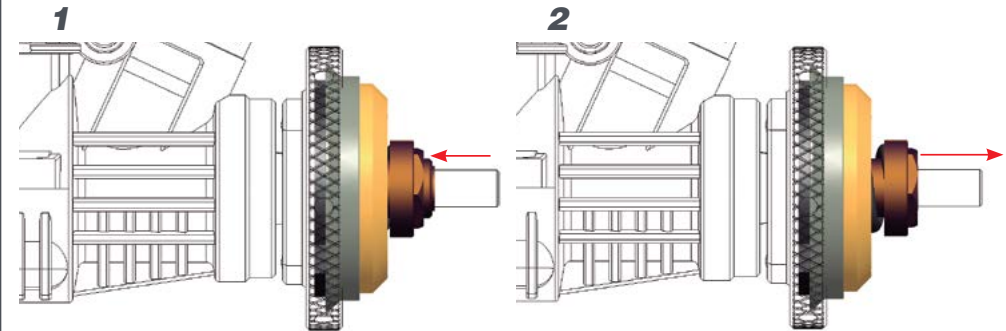

STEP 57

57.1

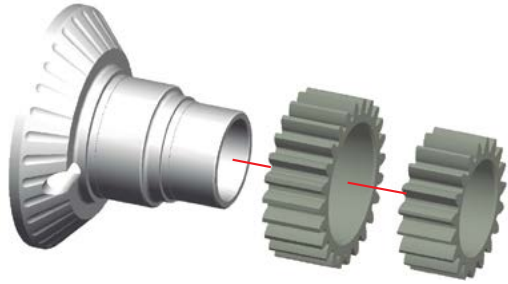

! Note the orientation of the gears

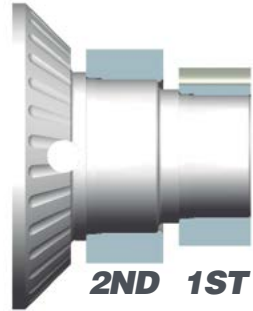

57.2

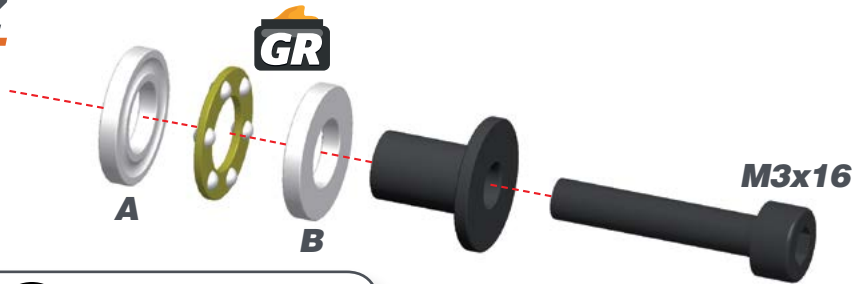

! IMPORTANT! Install thrust bearing plates as shown.

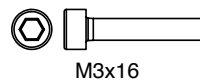
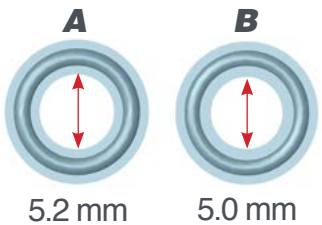

STEP 58

58.1 SETTING THE CLUTCH GAP

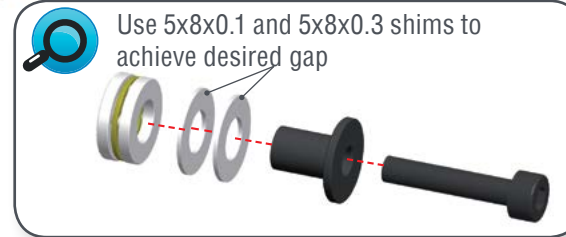
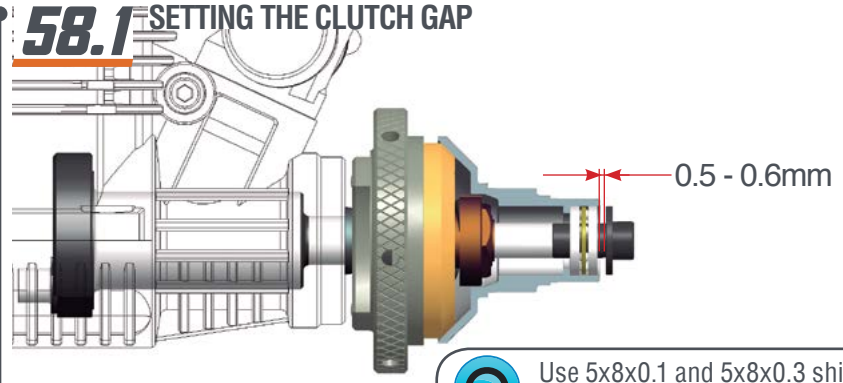

58.2 SETTING THE CLUTCH END PLAY

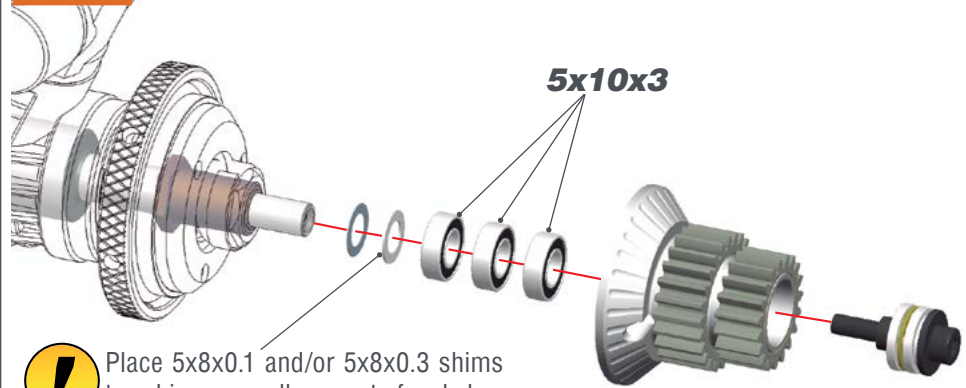

! Place 5x8x0.1 and/or 5x8x0.3 shims to achieve a small amount of end play.

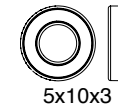

STEP 59 BAG 13

59.1

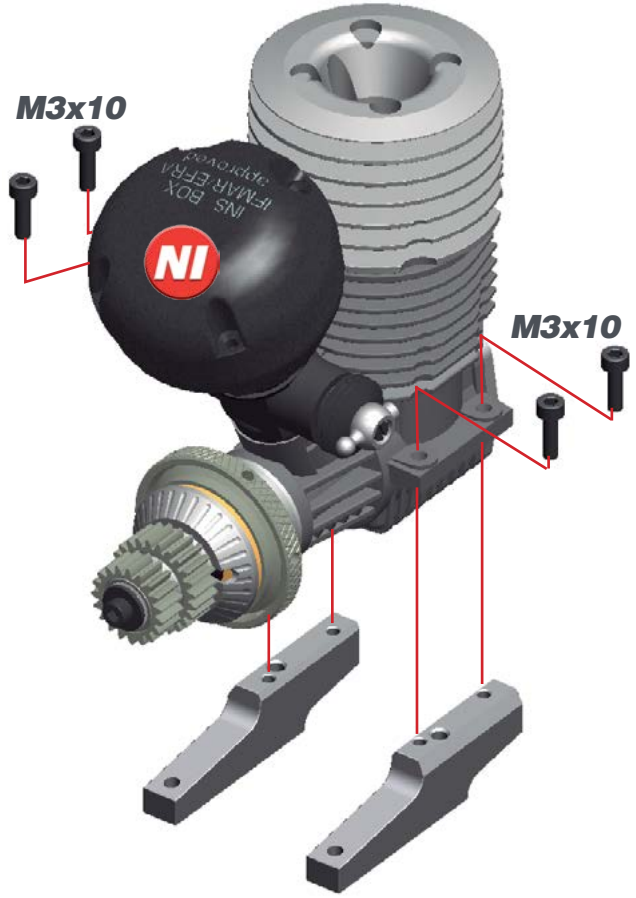

59.2

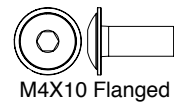
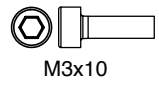
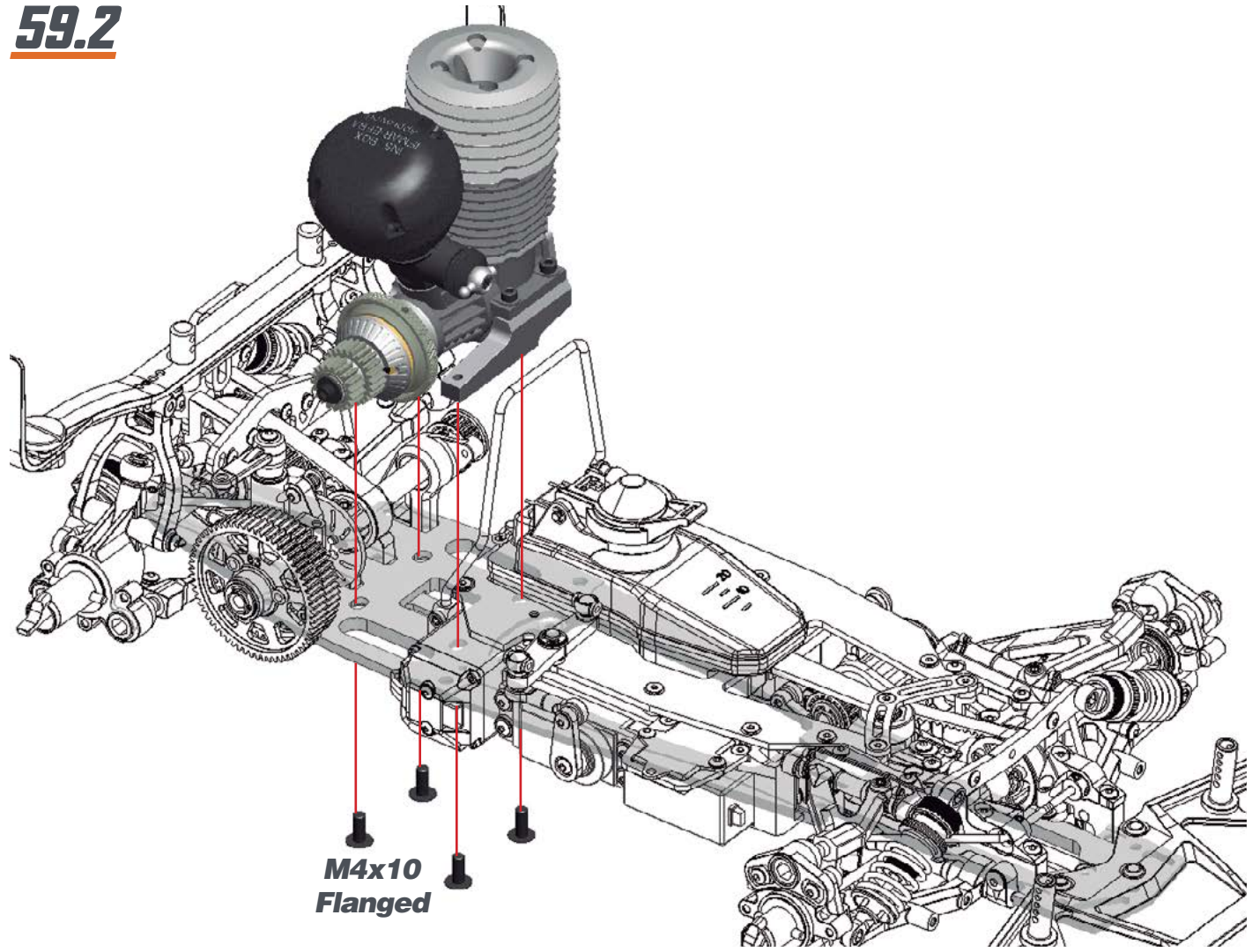

STEP 60

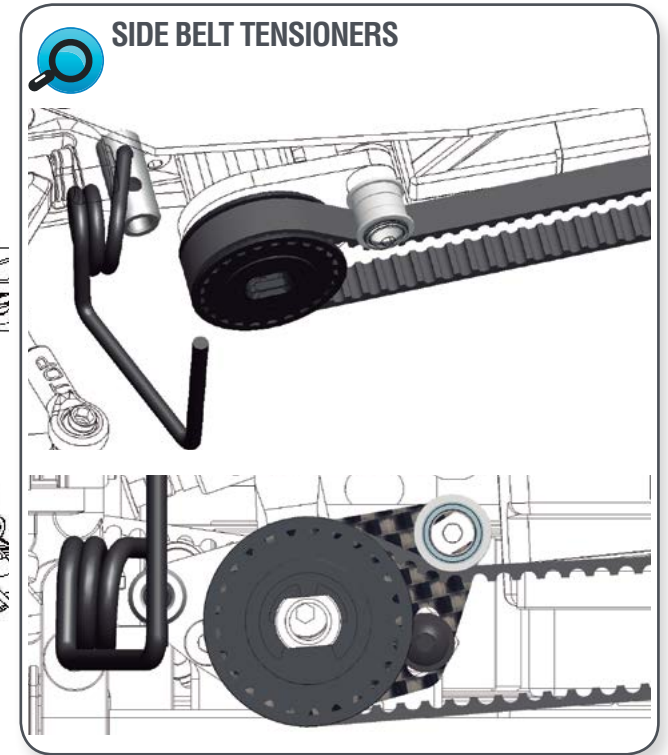
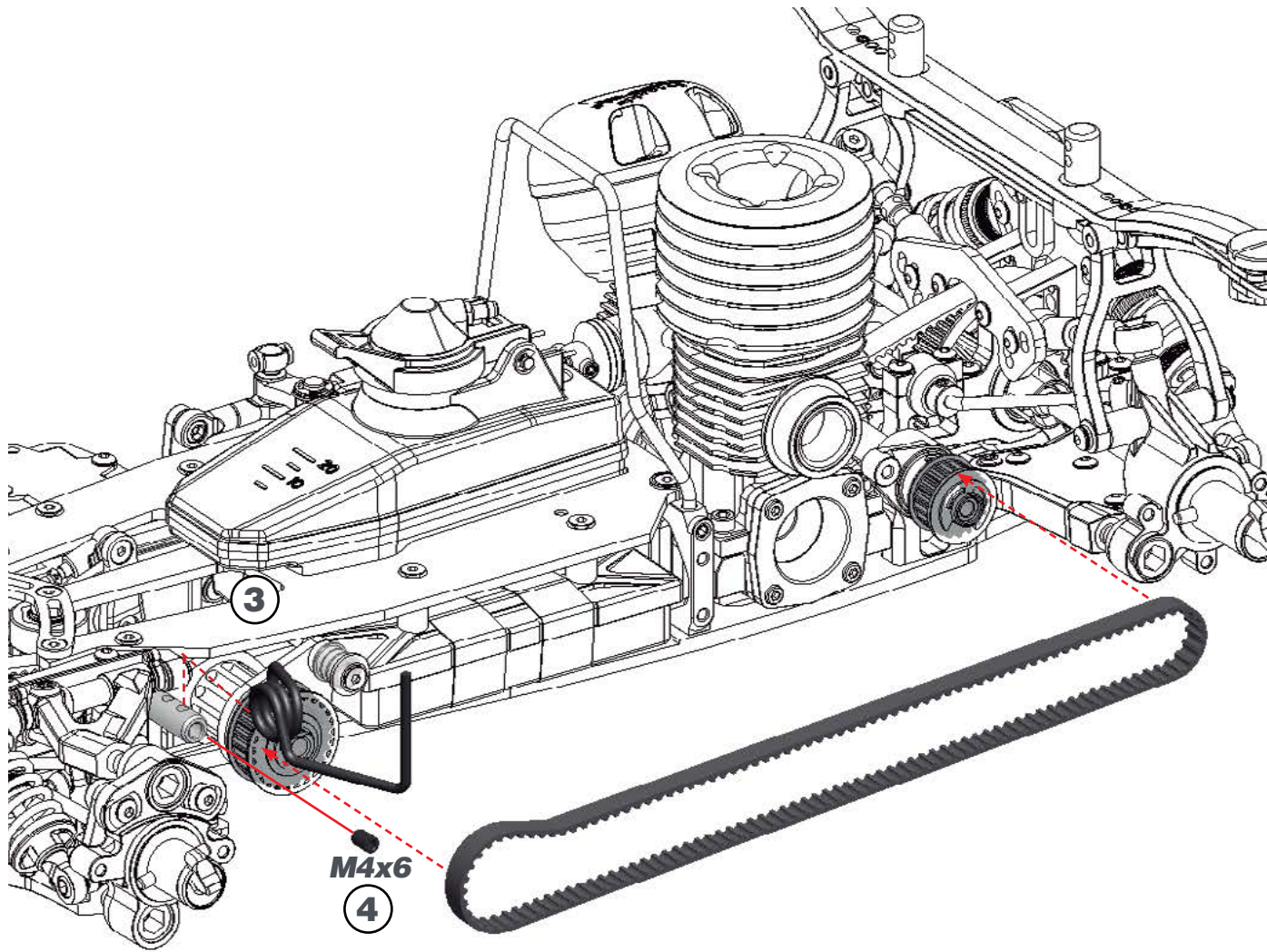

STEP 61

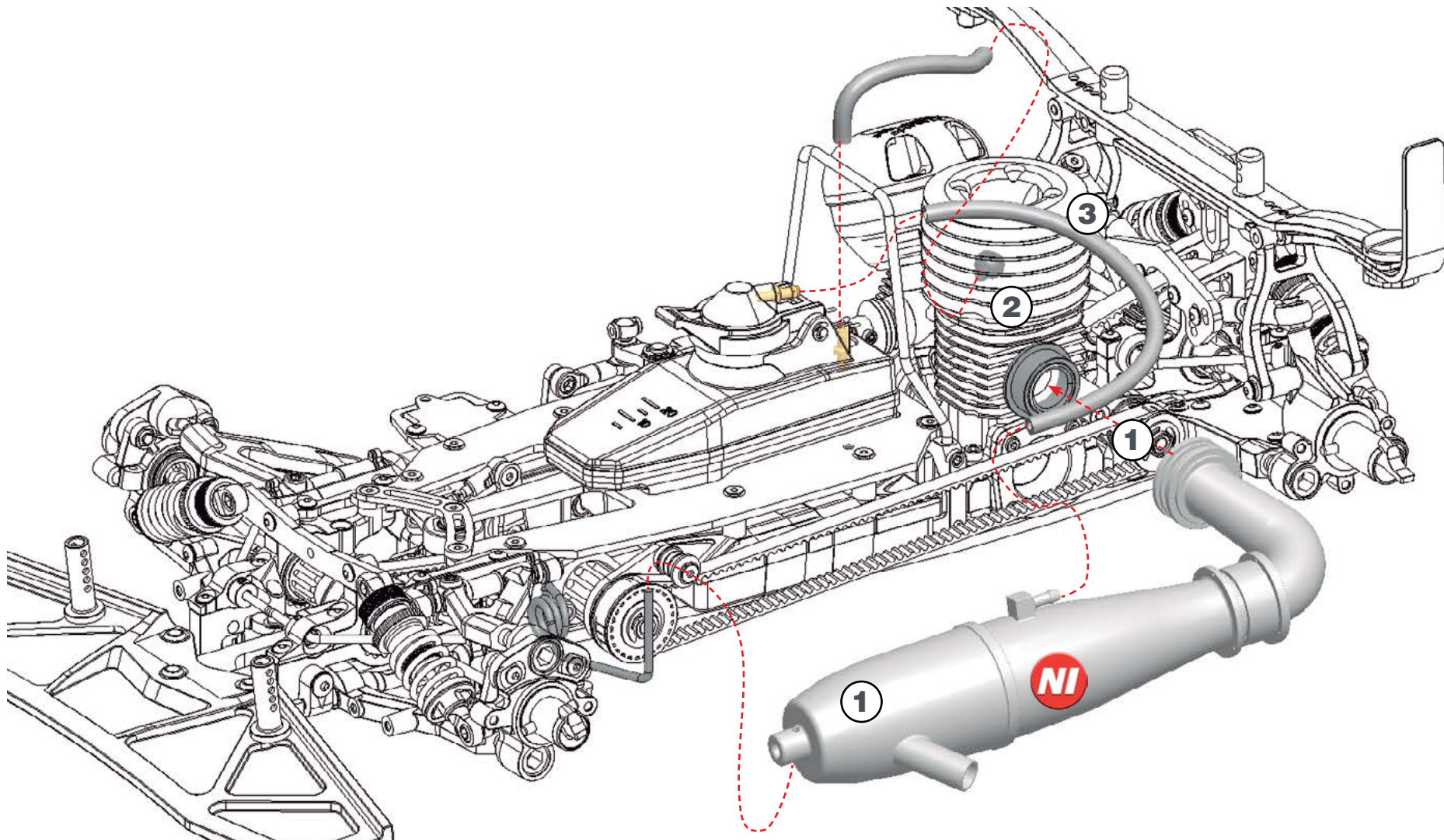

STEP 62

62.1

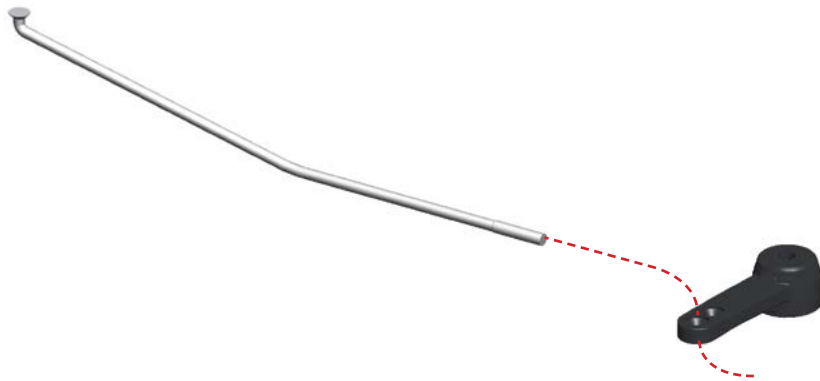

62.2

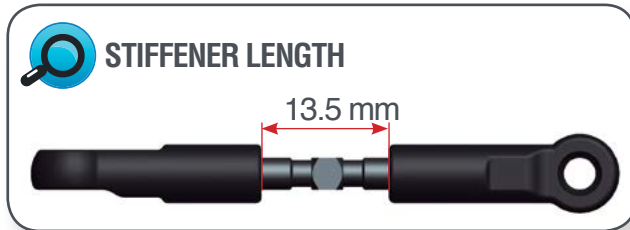

62.3

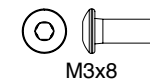
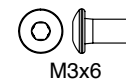
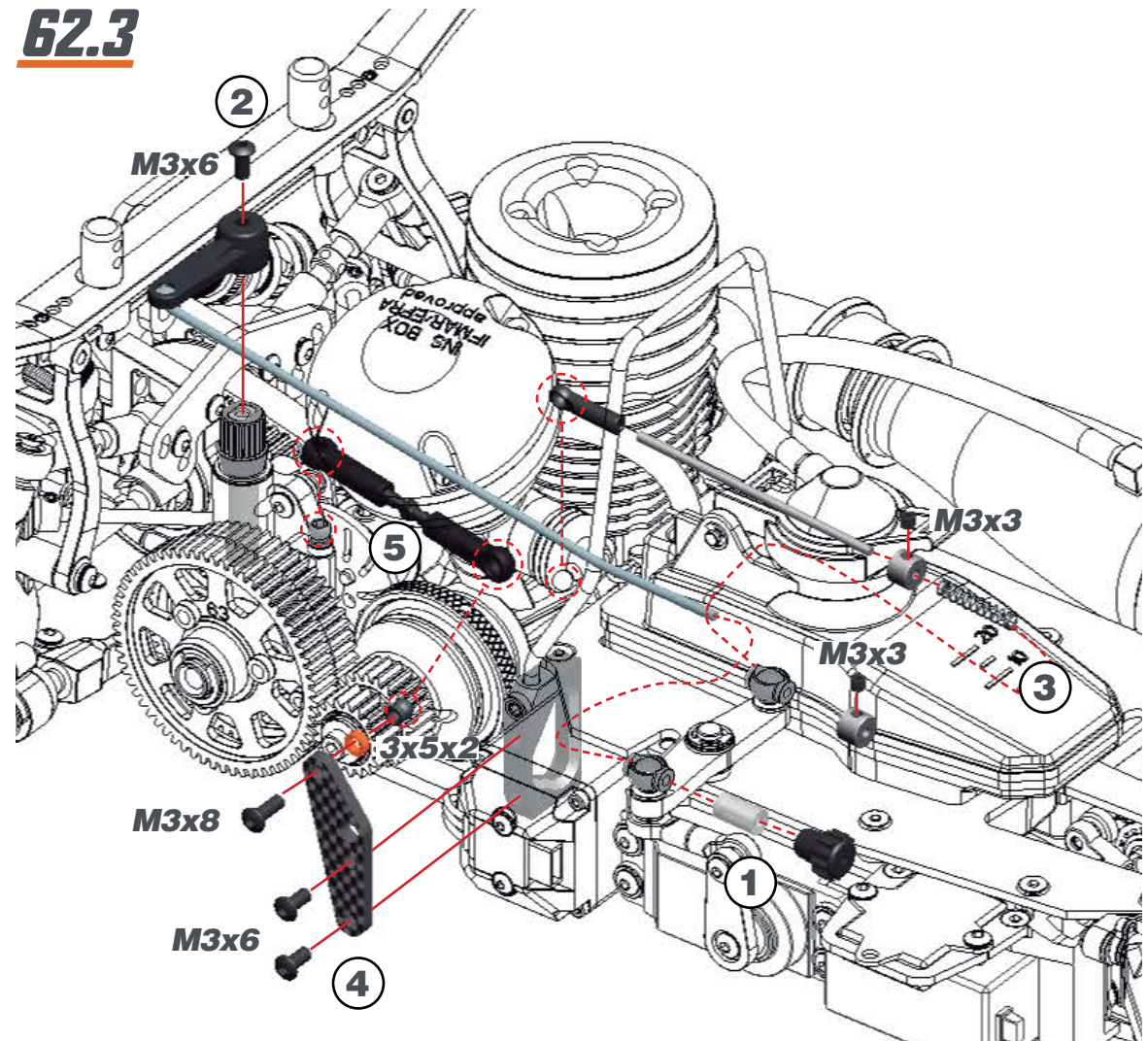

STEP 63

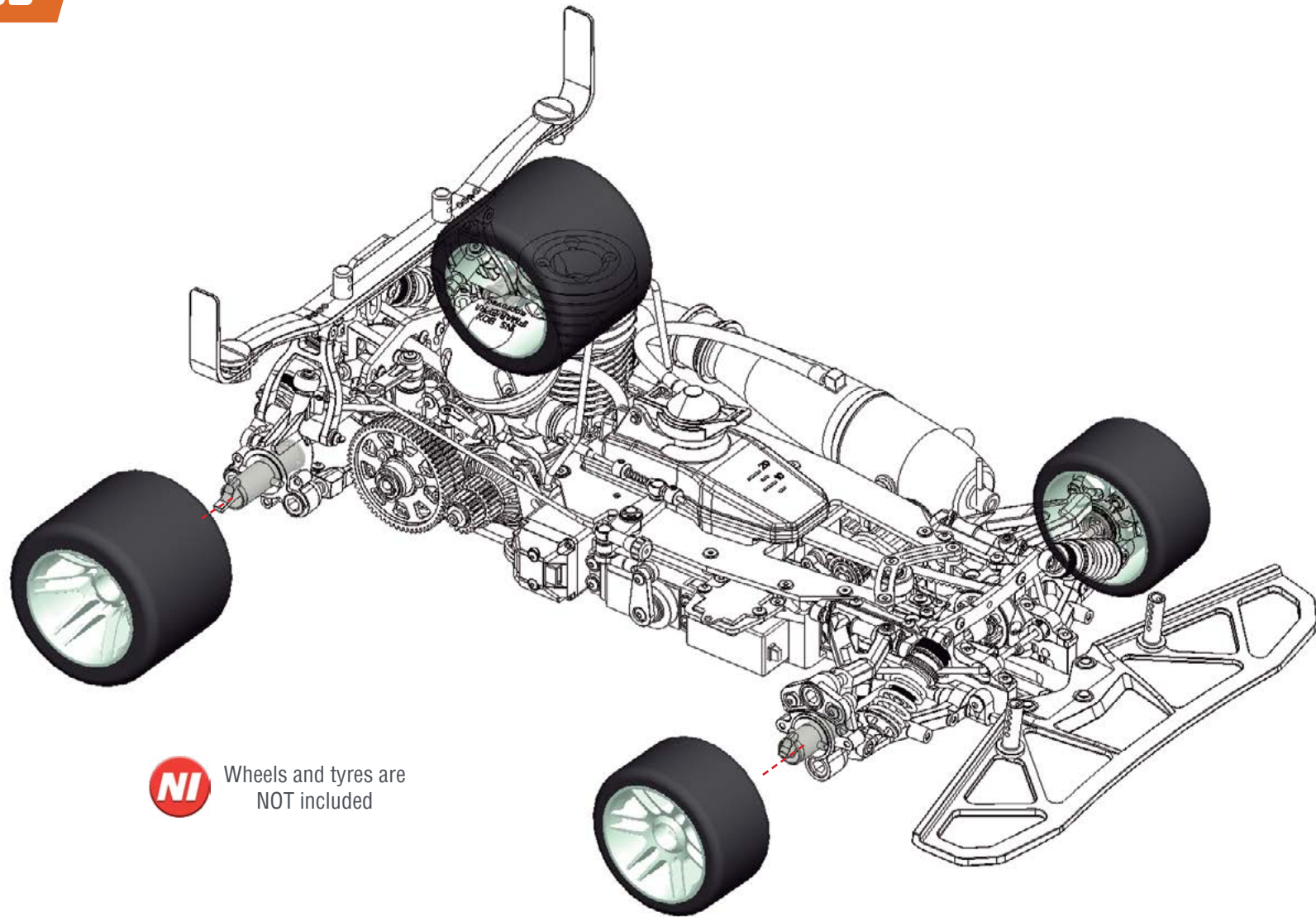

Wheels and tyres are
NOT included

INDEX

CLUTCH AND GEARBOX EXPLODED VIEW	47
SHOCKS EXPLODED VIEW	48
REAR EXPLODED VIEW	49
FRONT I EXPLODED VIEW	50
RADIO EXPLODED VIEW	51
FRONT II EXPLODED VIEW	52
BUMPER AND BODYMOUNT EXPLODED VIEW	53
FINAL EXPLODED VIEW	54
TEAM SERPENT NETWORK	55

CLUTCH AND GEARBOX EXPLODED VIEW

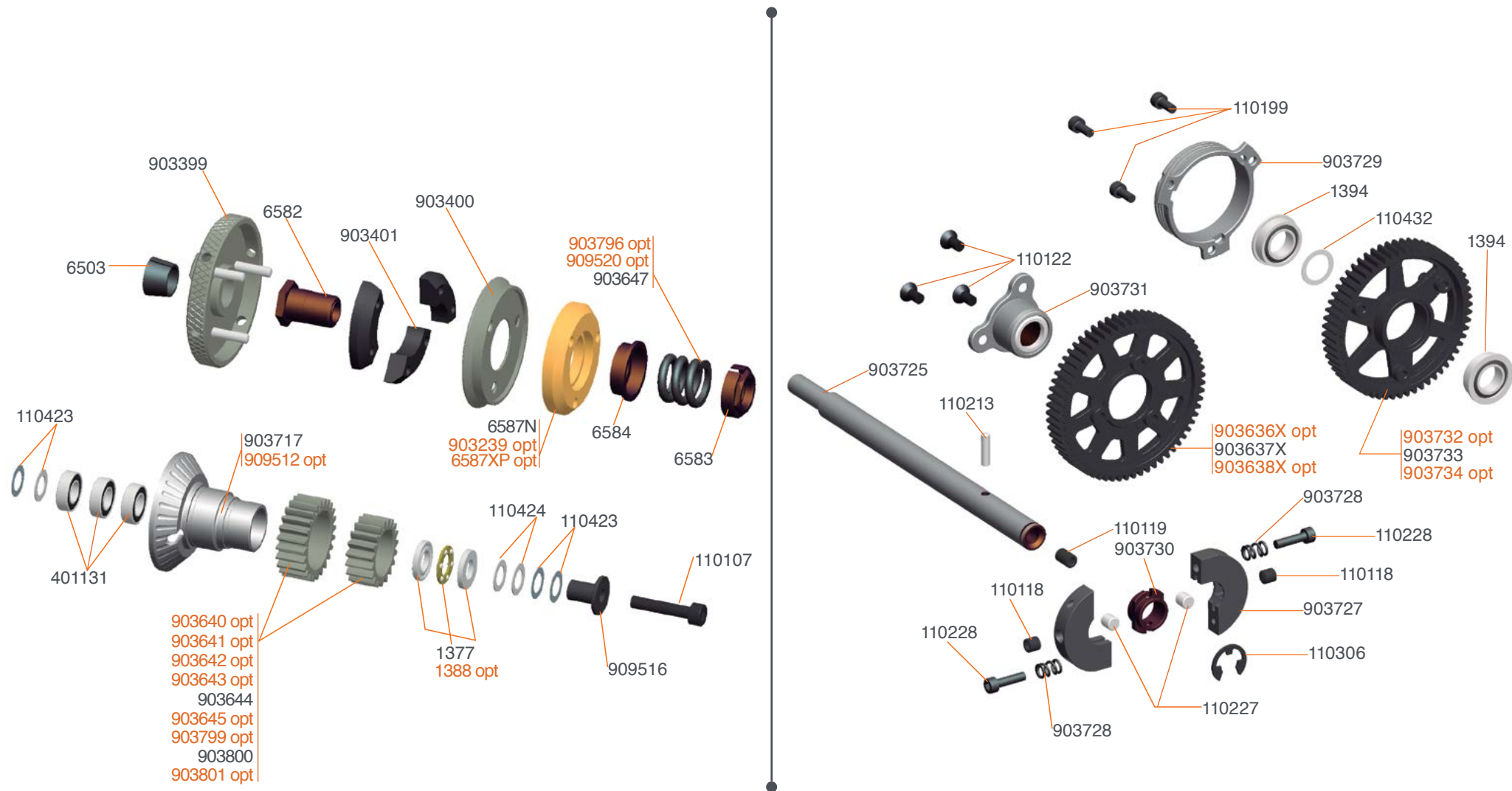

- 6587XP Centax clutch shoe XP
- 903239 Centax-2 clutch shoe red
- 903640 Centax gear-pinion alu 18T XLI
- 903641 Centax gear-pinion alu 19T XLI
- 903642 Centax gear-pinion alu 20T XLI
- 903643 Centax gear-pinion alu 23T XLI

- 903645 Centax gear-pinion alu 25T XLI
- 903646 Centax gear-pinion alu set XLI (6)
- 903636X 2-speed gear 61T SL8 XLI V2
- 903638X 2-speed gear 63T SL8 XLI V2
- 903732 2-speed gear 56T XLI Gen2
- 903734 2-speed gear 58T XLI Gen2

- 903771 2-speed gear set (6) XLI Gen2
- 909512 Centax II clutch-housing universal
- 903796 Centax spring XX-hard
- 903799 Centax gear-pinion alu 18T XLI Gen2
- 903801 Centax gear-pinion alu 20T XLI Gen2



903741 Shockset XLV short (2)

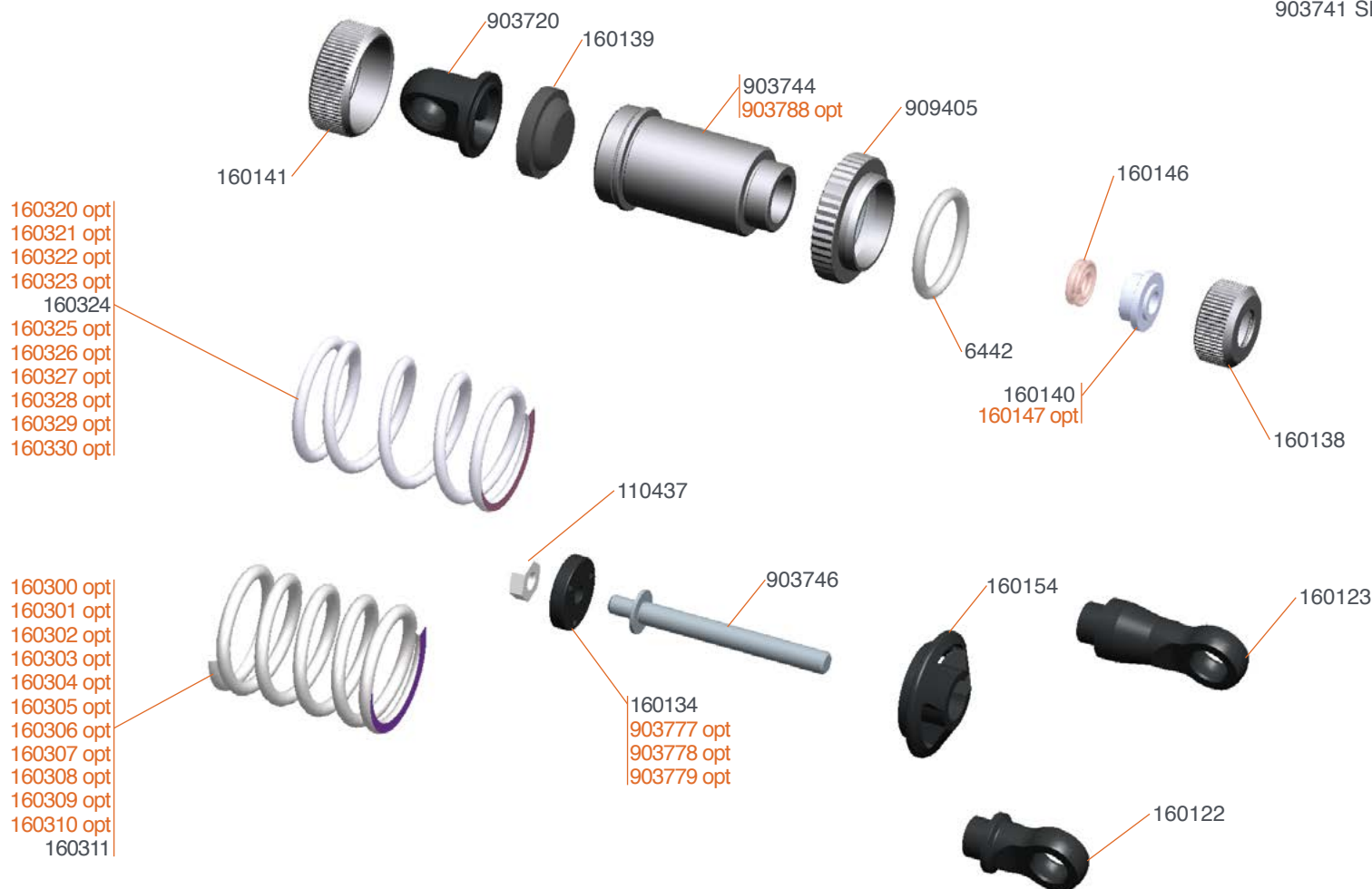

- 160147 Shock onroad big bore bushing LF (4)
- 160300 Spring white L23 (2.3/13) (2)
- 160301 Spring yellow L23 (2.8/16) (2)
- 160302 Spring orange L23 (3.4/19.5) (2)
- 160303 Spring red L23 (4.1/23.5) (2)
- 160304 Spring pink L23 (4.0/28) (2)
- 160305 Spring blue L23 (5.8/33) (2)
- 160306 Spring purple L23 (6.8/39) (2)
- 160307 Spring green L23 (8/45.5) (2)
- 160308 Spring grey L23 (9/51.5) (2)

- 160309 Spring black L23 (10/57) (2)
- 160310 Spring-set short (5x2)
- 160320 Spring white L27 (2.3/13) (2)
- 160321 Spring yellow L27 (2.8/16) (2)
- 160322 Spring orange L27 (3.4/19.5) (2)
- 160323 Spring red L27 (4.1/23.5) (2)
- 160325 Spring blue L27 (5.8/33) (2)
- 160326 Spring purple L27 (6.8/39) (2)
- 160327 Spring green L27 (8/45.5) (2)
- 160328 Spring grey L27 (9/51.5) (2)

- 160329 Spring black L27 (10/57) (2)
- 160330 Spring-set L27 (5x2)
- 903777 Shock piston XLV 1 hole (4)
- 903778 Shock piston XLV 2 hole (4)
- 903779 Shock piston XLV 3 hole (4)
- 903780 Heave demper set rear
- 903781 Heave demper set front
- 903788 Shockbody XLV short NiCoated (2)



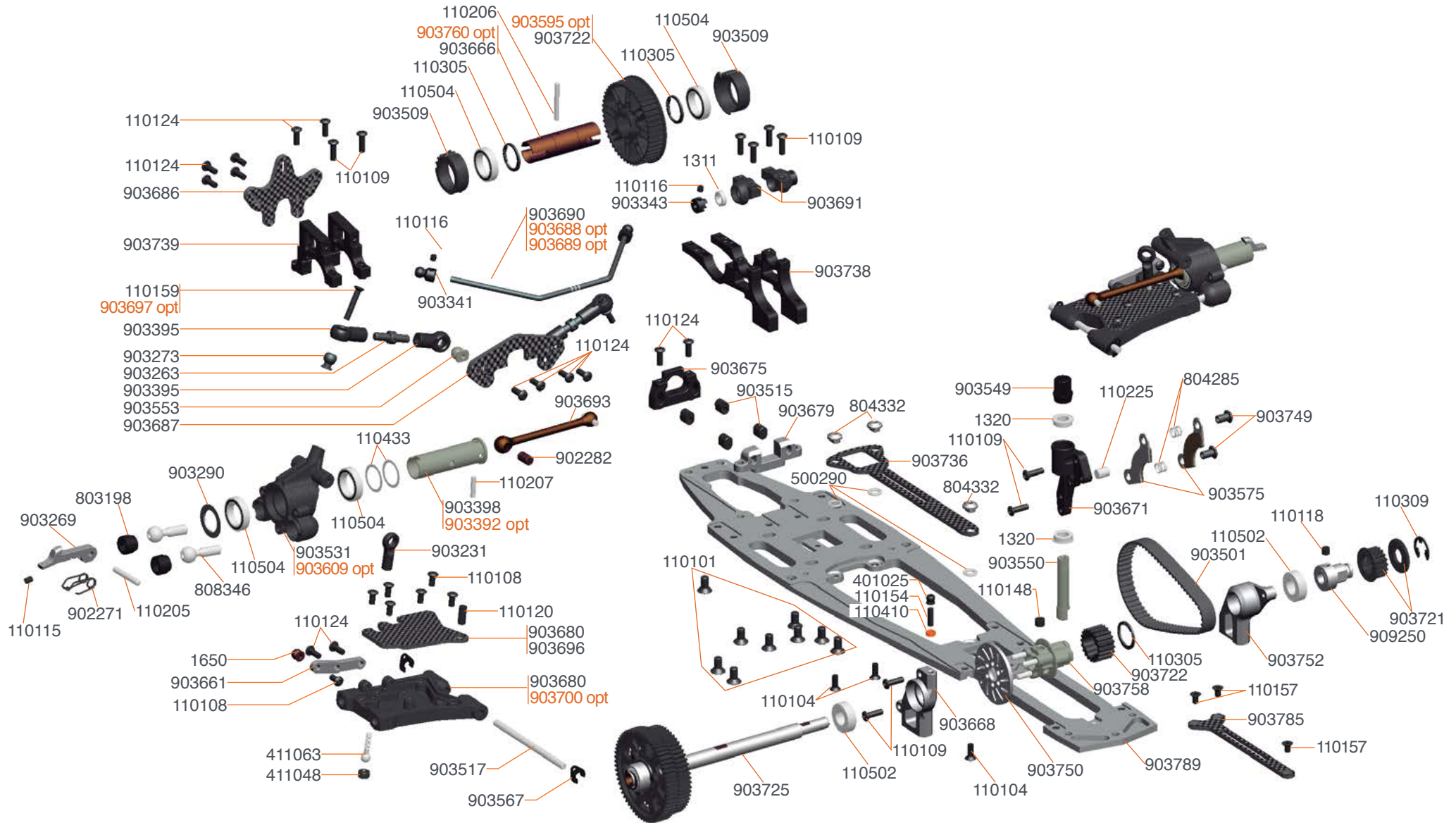

- 903392 Wheel-axle CVD RR (2)
- 903595 Pulley rear axle 48T alu
- 903609 Upright (2) hard
- 903688 Antirroll bar FR/RR soft S988
- 903689 Antirroll bar FR/RR medium S988

- 903697 Camberlink riser 1/8 (2)
- 903700 Wishbone RR lw L+R hard S988
- 903759 Chassis weight 14gr brass S989
- 903760 Solidaxle light S989



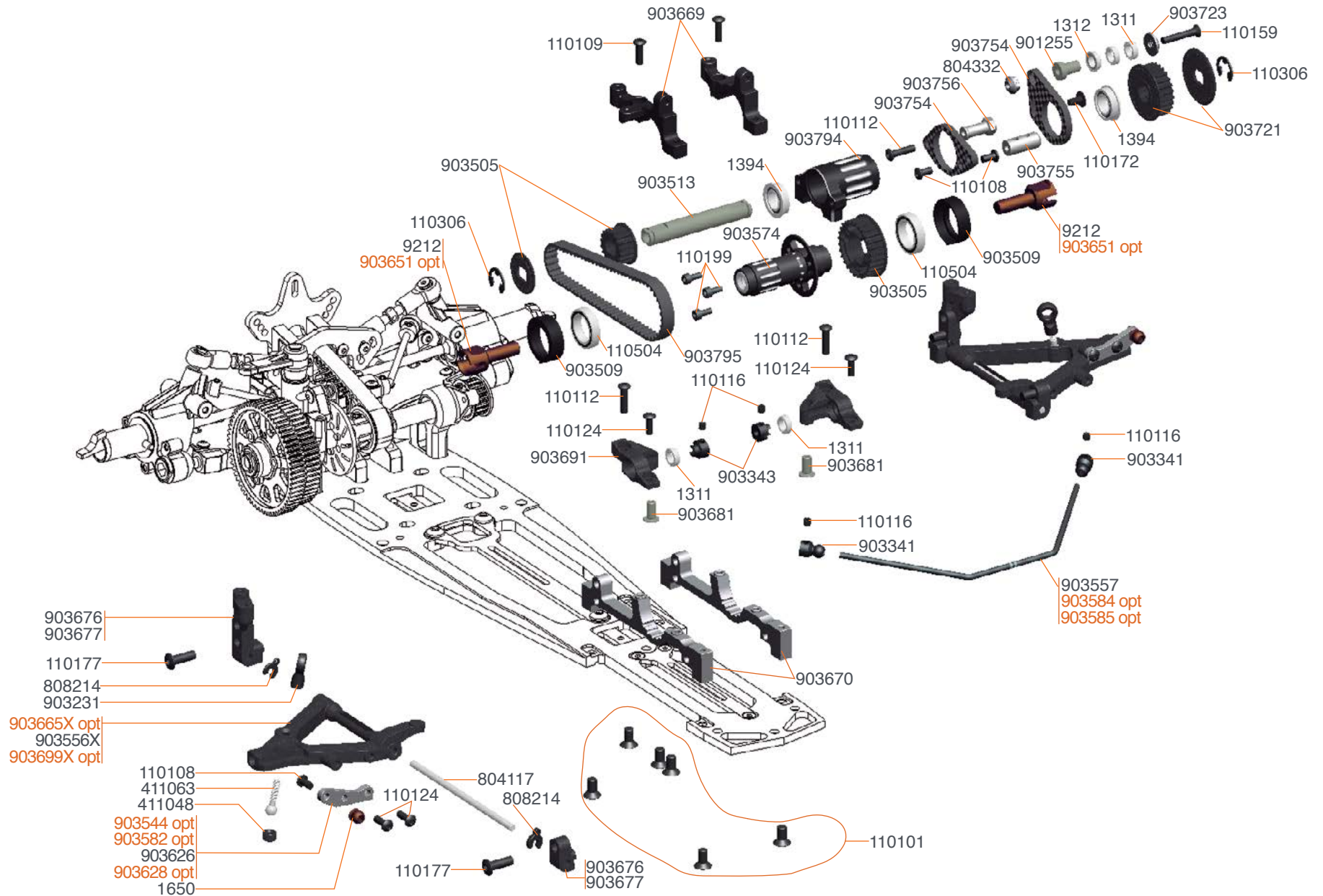

- 903544 Shock extension bracket FR alu (2)
- 903584 Antiroll bar FR soft S989
- 903585 Antiroll bar FR hard S989
- 903582 Shock extension bracket FR carbon (2)

- 903628 Shock extension bracket FR wide carbon (2)
- 903650 Oneway front axle Hard anodized
- 903651 Inner driveshaft adapter light
- 903665X Wishbone FR lw V2 L+R S988

- 903695 Wishbone insert carbon FR lw (2)
- 903699X Wishbone FR lw V2 L+R hard S988



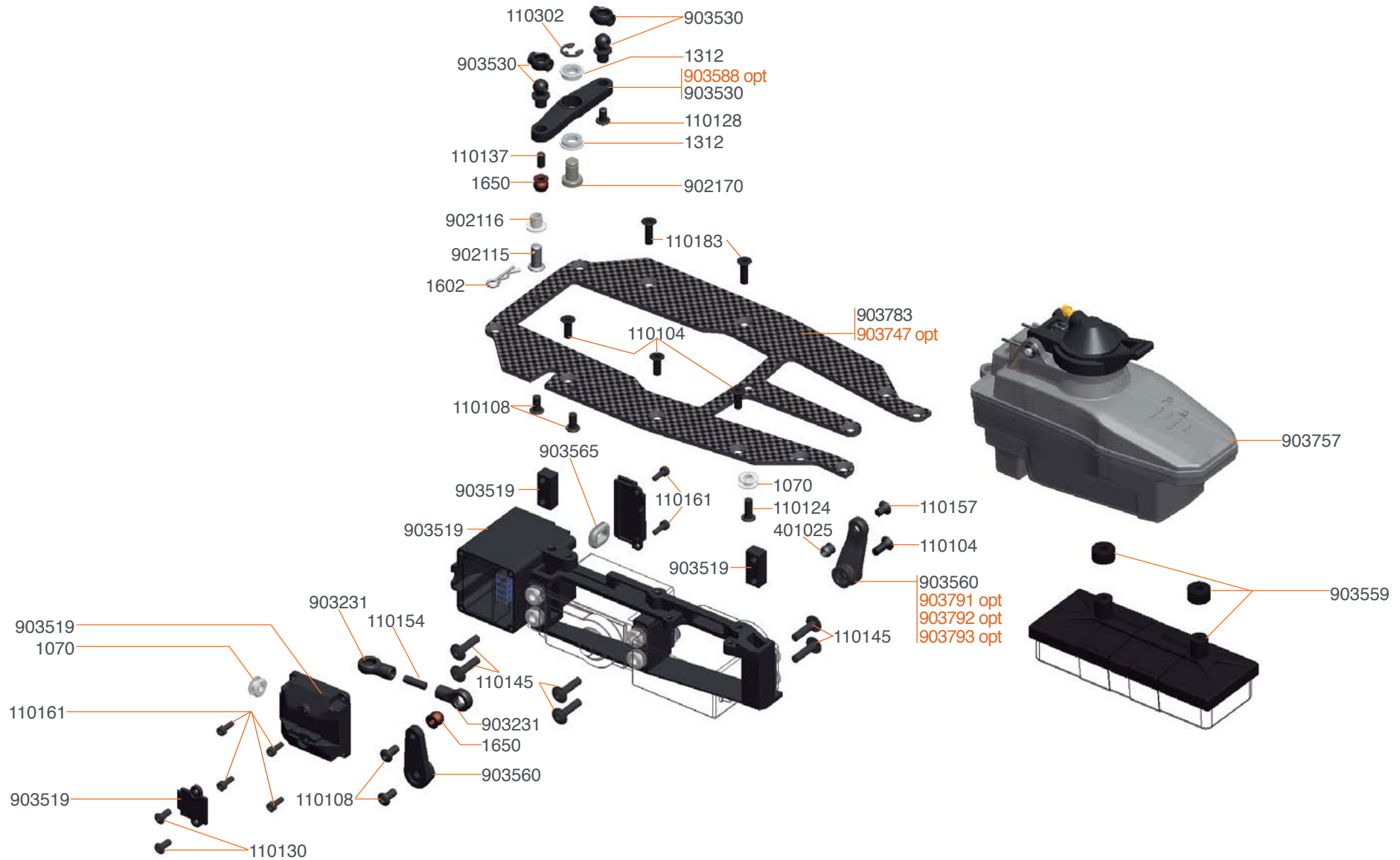

903588 Throttle lever alu
 903747 Radioplate carbon S989
 903791 Servo lever 23T alu
 903792 Servo lever 24T alu

903793 Servo lever 25T alu

FRONT II EXPLODED VIEW

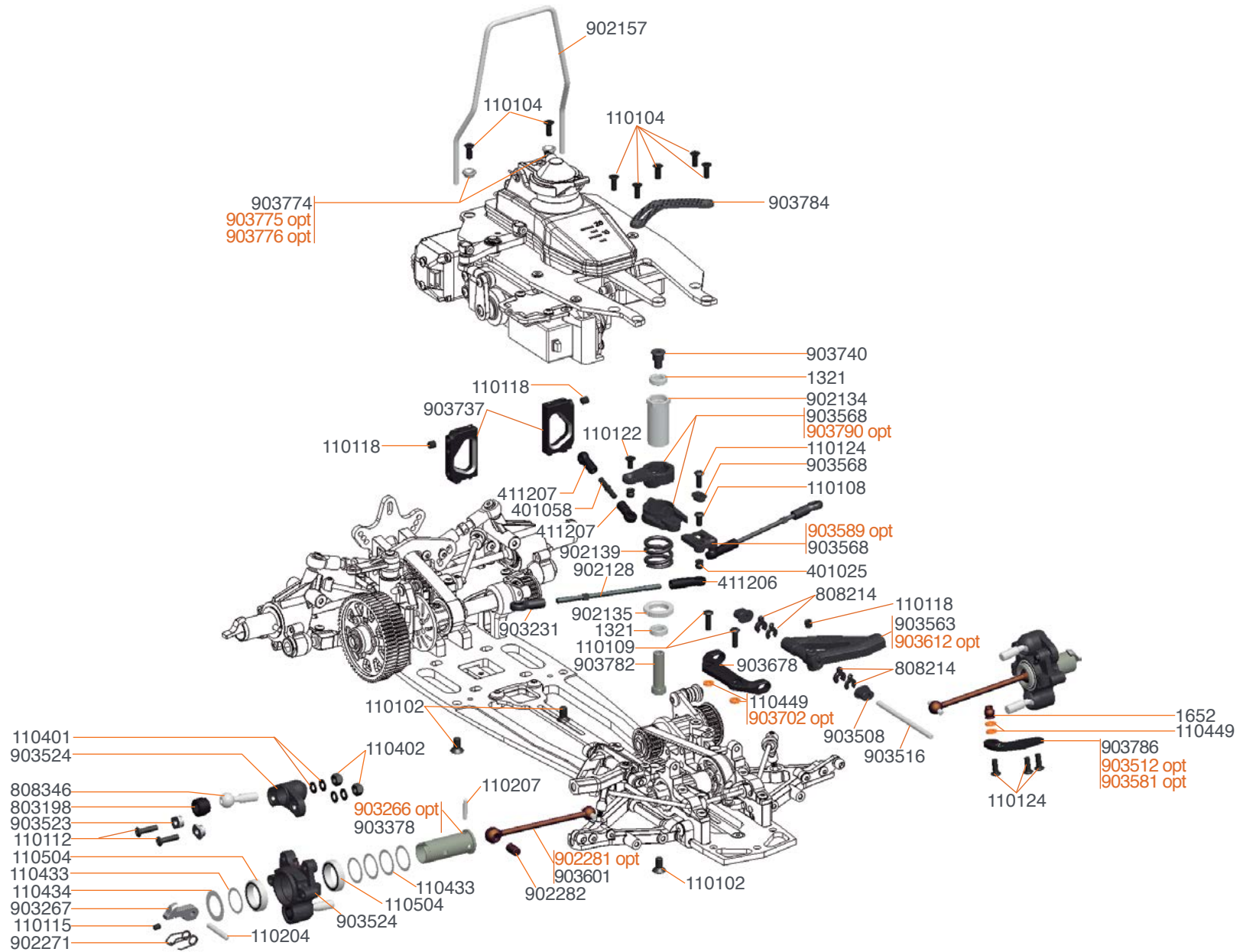

- 903266 Wheel-axles OS2 RR (2)
- 903512 Steeringblock lever alu (2)
- 903581 Steeringblock lever carbon (2)
- 903589 Servosaver bottom alu (2)

- 903601 Driveshaft cvd FR alu (2)
- 903612 Wishbone FR up (2) hard
- 903702 Rollcenter spacer fr (2) S988
- 903775 Flex set S989

- 903776 Flex insert (2) S989
- 903790 Servosaver top alu

BUMPER AND BODYMOUNT EXPLODED VIEW

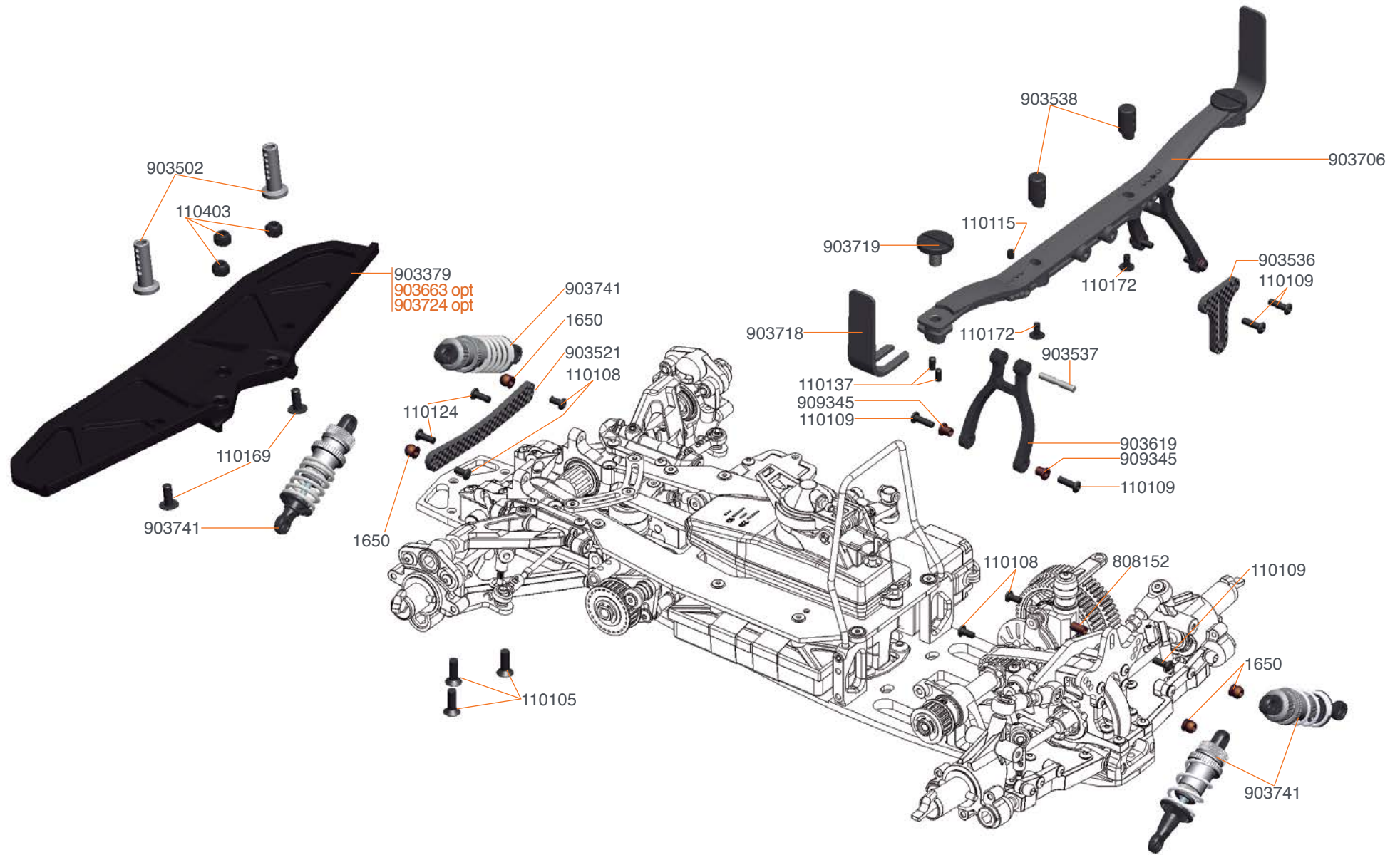

- 903663 Bumper 1/8 FLOW
- 903664 Bumper insert set (2+2) FLOW
- 903724 Bumper light S989
- 903764 Bodymount pro set

- 903765 Bodymount center pro
- 903766 Bodymount pro post alu (2)
- 903767 Bodymount pro pin mount alu (2)
- 903768 Bodymount pro extension mount alu (2)

- 903769 Bodymount pro extension carbon (2)
- 903770 Bodymount pro support plate carbon

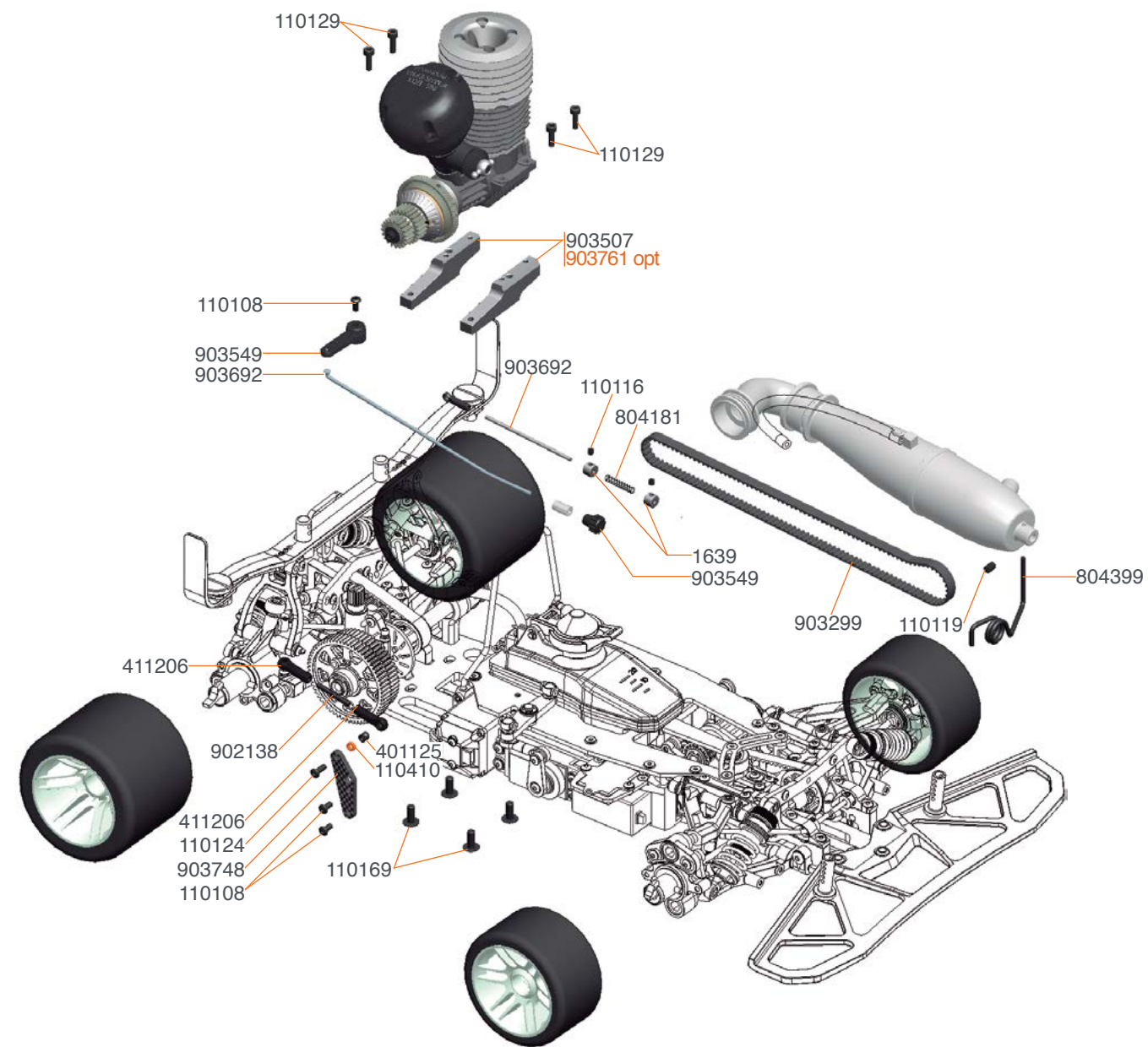

903761 Enginemount alu L+R light S989

NOTES:

TEAM SERPENT NETWORK

989 SPARE PARTS www.serpent.com/903019/spares/



989 OPTIONALS PARTS www.serpent.com/903019/Optionals/



SERPENT TOOLS www.serpent.com/product/Tools/



SERPENT MERCHANDISING www.serpent.com/product/Merchandising/



SERPENT WEBSITE AND BLOG

www.serpent.com

www.teamserpent.com

www.dragon-rc.com

SERPENT PROMO PAGES <http://promo.serpent.com>

SERPENT FACEBOOK GROUPS <http://promo.serpent.com/indexfb.htm>

SERPENT ADVANCED MANUALS <http://promo.serpent.com/sam/>

SERPENT SOCIAL MEDIA



www.facebook.com/SerpentMRC



www.youtube.com/user/SerpentMRC



www.twitter.com/SerpentMRC



www.plus.google.com/+SerpentModelcars/posts



www.weibo.com/teamserpent

SERPENT



**Instruction
Manual**



Manual 989 40th Anniversary #57574-1