

**Instruction  
Manual**

**VIPER  
989**



**SERPENT**



## **INTRODUCTION**

The Serpent Viper 989 is designed to be a world champion, while still being easy to use, assemble, and set up. The Serpent Viper 989 offers state of the art specifications and leads the way in chassis design, using all the knowledge we have from 1/8 scale racing into this design too. Continuously pushing the performance envelope, Serpent's engineers have added new and innovative features that help take your Serpent Viper 989 into the winner's circle.

Designed by Michael Salven

Team Serpent  
Multiple World Champions

## **INSTRUCTIONS**

Serpent's long tradition of excellence extends to the instruction manuals, and this instruction manual is no exception. The easy-to-follow layout is richly illustrated with 3D-rendered full-color images to make your building experience quick and easy. Following the instructions will result in a well-built, high-performance race-car that will soon be able to unleash its full potential at the racetrack. The kit includes bags, with bag numbers, which refer to the same step in the manual. Open only the indicated bag(s) per step and finish that part of the assembly. Remaining parts will be needed later on in the assembly process.

## **PLASTIC PARTS**

The Serpent moulded parts are very durable and hard. When assembling longer screws in new composite parts, make sure to use new hex bits in your (power) tools. Pre-threading also helps to avoid screw damage.

## **SETUP**

In certain assembly steps you need to make basic adjustments, which will give you a good initial setup for your Serpent Viper 989. Fine-tuning the initial setup is an essential part of building a high-performance racecar like your Serpent Viper 989.

## **EXPLODED VIEWS AND PARTS LIST**

The exploded views and parts lists for the Serpent Viper 989 are presented in the Reference Guide section in the back of this manual. The exploded views show all the parts of a particular assembly step along with the Serpent part number and hotlink to the Serpent website. Part numbers in orange indicates that this part is an optional. Optionals part names and numbers are showed below.

## **CUSTOMER SERVICE**

Serpent has made a strong effort to make this manual as complete and clear as possible. Additional info may be published in our website: [www.serpent.com](http://www.serpent.com) or you may ask your dealer or the Serpent distributor for advice, or email Serpent direct: [info@serpent.com](mailto:info@serpent.com). The Serpent Facebook, Twitter and Youtube pages give additional means of support and communications.

## **SAFETY**

Read and take note of the 'Read this First section' before proceeding to assemble the car-kit. This car-kit is intended for persons aged 16 or older.

## **READ THIS FIRST!**

- This is a highly technical hobby product, intended to be used in a safe racing environment. This car is capable of speeds in excess of 80 km/h or 50mph. Please follow these guidelines when building and operating this model.
- Parental guidance is required when the builder/user of this car is under 16.
- Follow the building instructions. If in doubt, contact your dealer or importer.
- Be sure to use the proper tools when assembling the car. Always exercise caution when using electric tools, knives and other sharp objects.
- Be careful when using liquids like lubrication oil, fuel or glue. Do not swallow.
- Follow the manufacturer's instruction in case you experience irritation after using the product.
- Be careful when operating the car. Stay away from any rotating parts such as wheels, gears and transmission. Stay away from motor, engine and exhaust pipe system or speedo during and immediately after use, as these parts may be very hot. We advise to use protective hand gloves.
- Only operate this car in a safe environment, like a special racing track or a closed parking lot. Avoid using this car on public roads, crowded places or near infants.
- Before operating this car, always check the mechanical status of the car. Also check that the transmitter and receiver frequencies correspond and are not used by any other racer at the same time. Check that the batteries of the transmitter and receiver- are fully charged.
- After use, always check all the mechanics of the car. We advise to clean the car immediately after use, and inspect the parts for wear or fractures. Replace when necessary. Do not use water, methanol, thinner or other solvents to clean the car.
- Empty the fuel tank (depending on model) if needed and disconnect the receiver battery.
- Store the car in a dry and heated place to avoid corrosion of metal parts.
- Avoid using this car in wet conditions as the water will cause corrosion on the metal parts and bearings and these parts will cease to function properly. If driven in the wet, ensure that all the electric equipment is waterproofed and after use, that all moving parts are dried immediately.

## **CONTENTS**

•		
•	<b>REAR ASSEMBLY</b>	<b>4</b>
•	<b>GEARBOX ASSEMBLY</b>	<b>17</b>
•	<b>FRONT I ASSEMBLY</b>	<b>18</b>
•	<b>RADIO ASSEMBLY</b>	<b>25</b>
•	<b>FRONT II ASSEMBLY</b>	<b>31</b>
•	<b>SHOCKS ASSEMBLY</b>	<b>34</b>
•	<b>CLUTCH ASSEMBLY</b>	<b>39</b>
•	<b>FINAL ASSEMBLY</b>	<b>41</b>
•	<b>EXPLODED VIEWS</b>	<b>46</b>
•	<b>TEAM SERPENT NETWORK</b>	<b>56</b>



## LINES DESCRIPTION

Each step contains a variety of numbers, lines, and symbols. The numbers represent the order in which the parts should be assembled. The lines are described below.



Step number; the order in which you should assemble the indicated parts



Length after assembly



Assembly path of one item into another



Group of items (within lines) should be assembled first



Direction the item should be moved



Glue one item to another



Connect one item to another



Gap between two items



Press/Insert one item into another

## ICONS DESCRIPTION

Each step contains a variety of symbols described below.



Carefull, read and check very well.



Apply a small amount of cyano glue. Use wear protection for eyes and hands.



Detail view to explain assembly or order of parts better.



Default set-up: This symbol indicates the default setup.



Grease: apply a small amount of grease to the parts shown.



Silicone grease: apply a small amount of grease to the parts shown.



Thread lock: apply a small amount on the parts shown. Before to apply the threadlock, make sure to degrease the parts very well, as otherwise the threadlock will not work.



Silicone oil: use the indicated silicone oil for the shocks and differentials.



Oil: apply a small amount of oil to the parts shown.



Left and right parts should be assembled in the same way.



Parts or items not included in the kit.



Optional part, not standard in the kit.

**STEP 1**

**BAG 1**

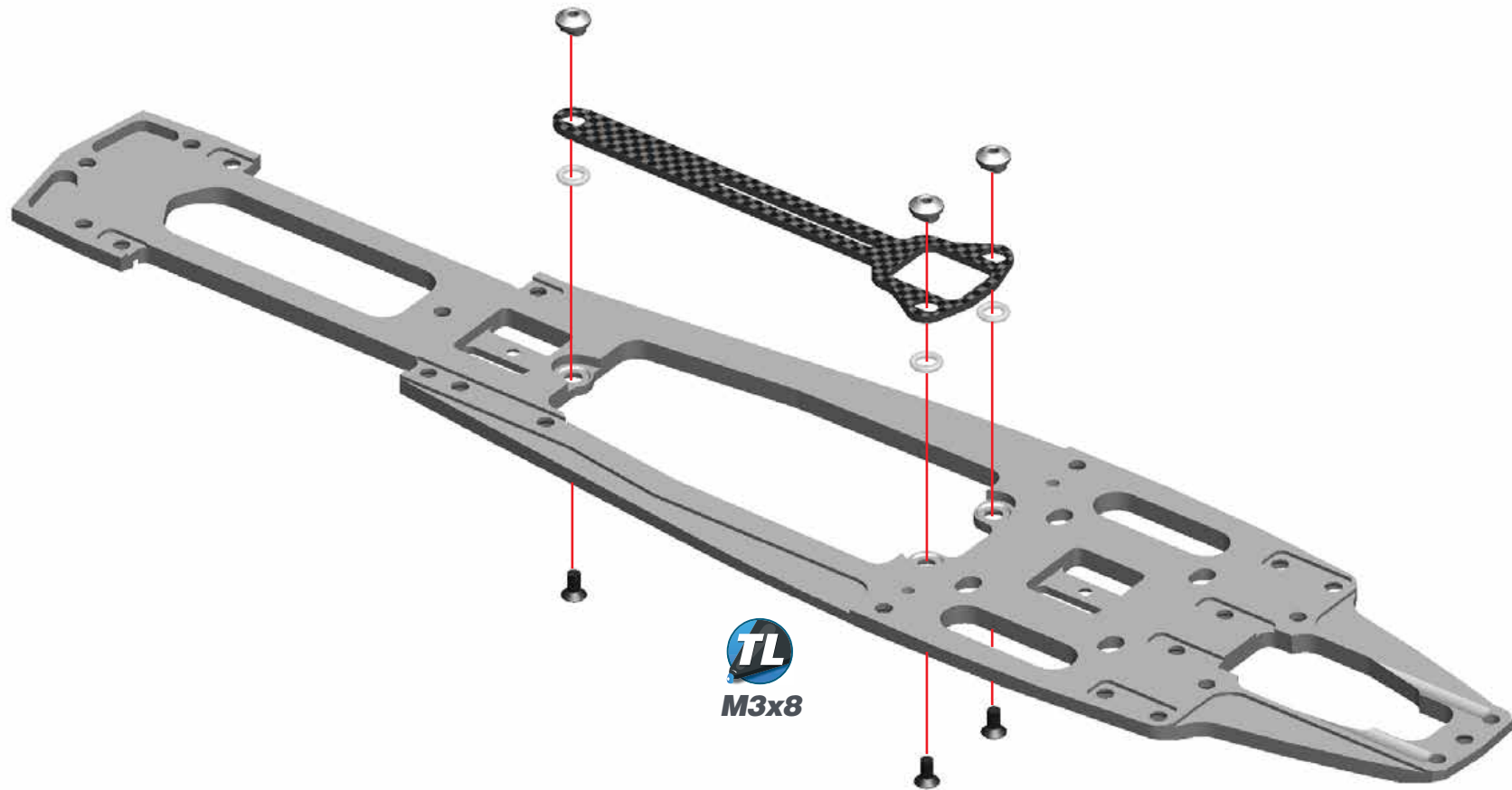



**TL**  
M3x8

  
M3x8

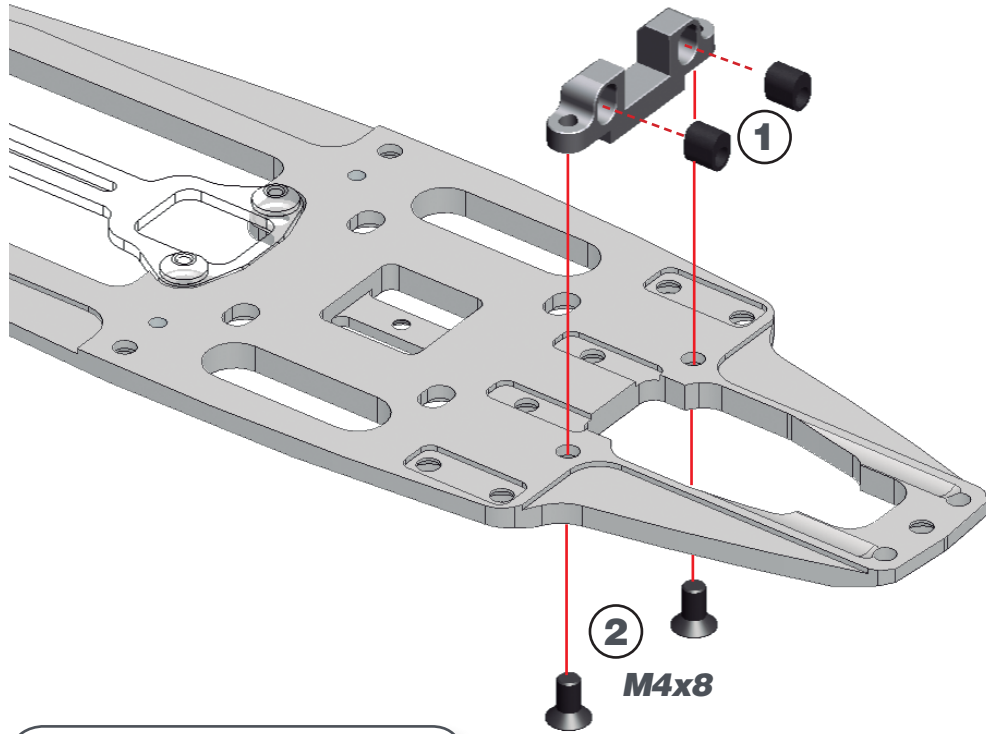

**STEP 2**



 **L=R** REAR ROLL CENTER  
INSERTS CHART

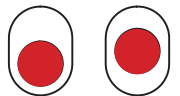



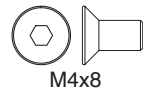

**STEP 3**

**L=R**

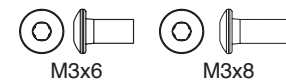

**STEP 4**

**L=R**

**M4x10**



**STEP 5**

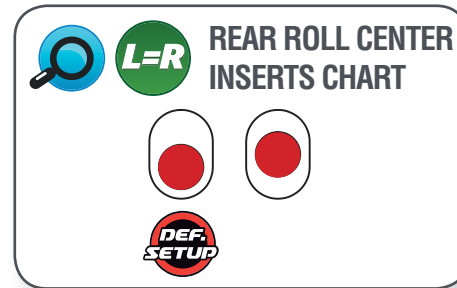
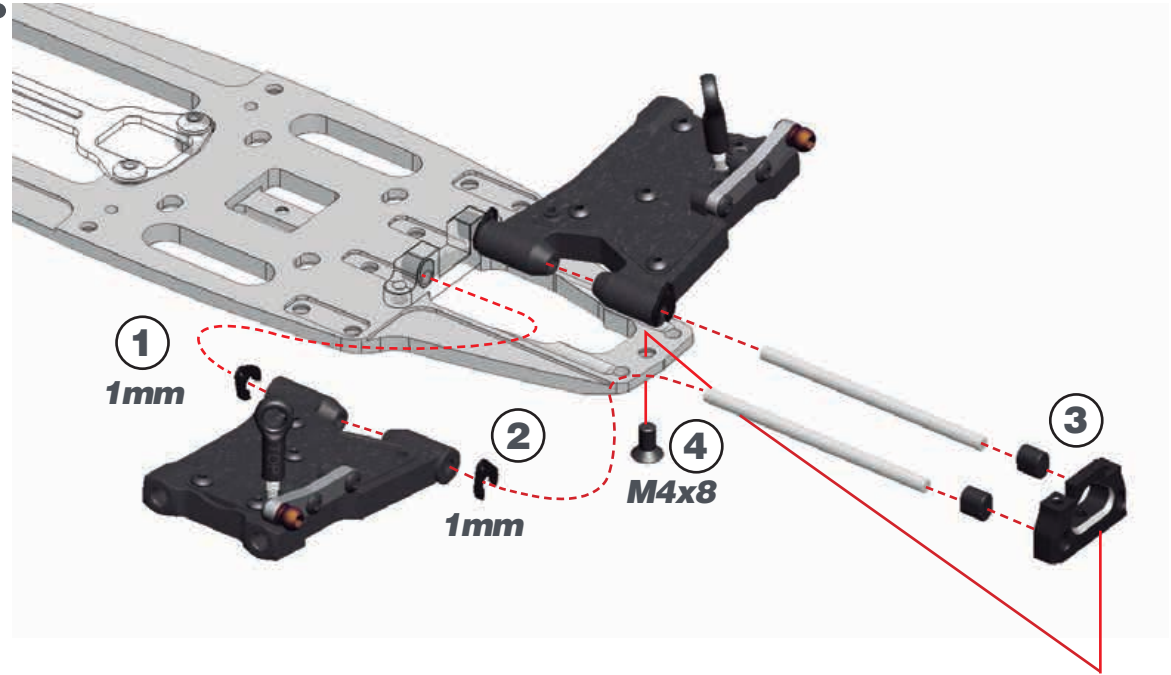



**STEP 6**

**BAG 2**

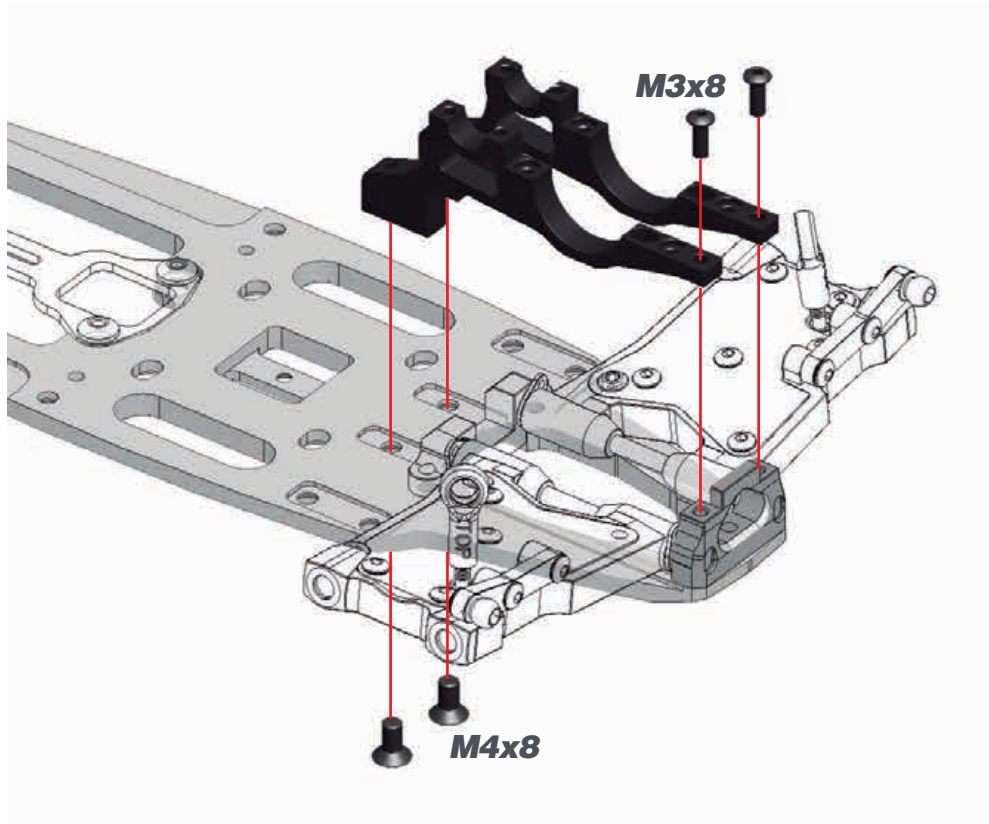

**STEP 7**

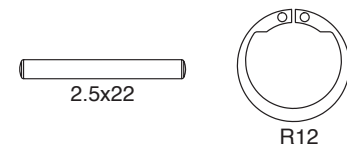
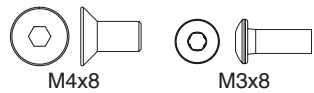
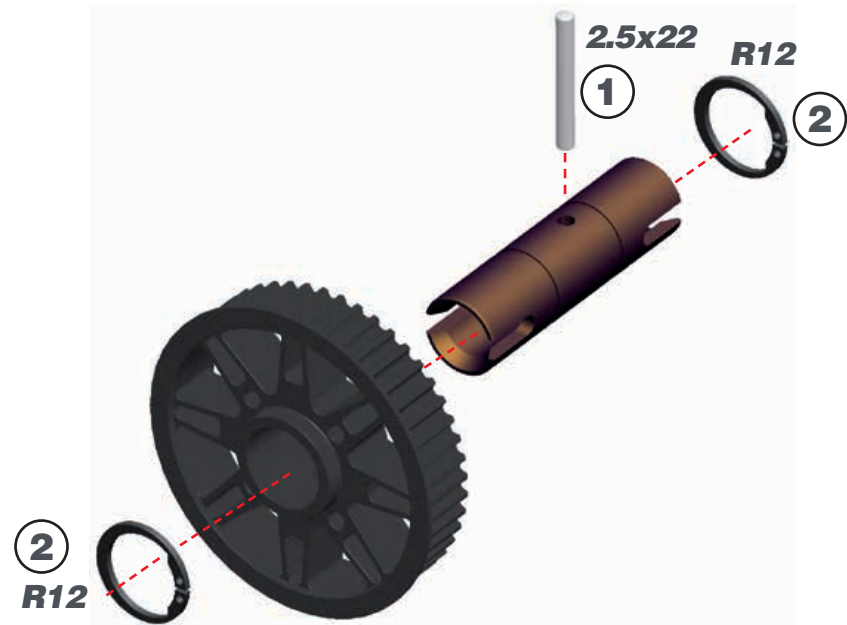

**STEP 8**

**REAR SOLID AXLE EXCENTERS**  
 Note that the rear solid axle excenters are not symmetrical and are marked with L (=left) and R (=right).

**LEFT**      **RIGHT**

**REAR BELT TENSION**  
 Use the central slot as starting position

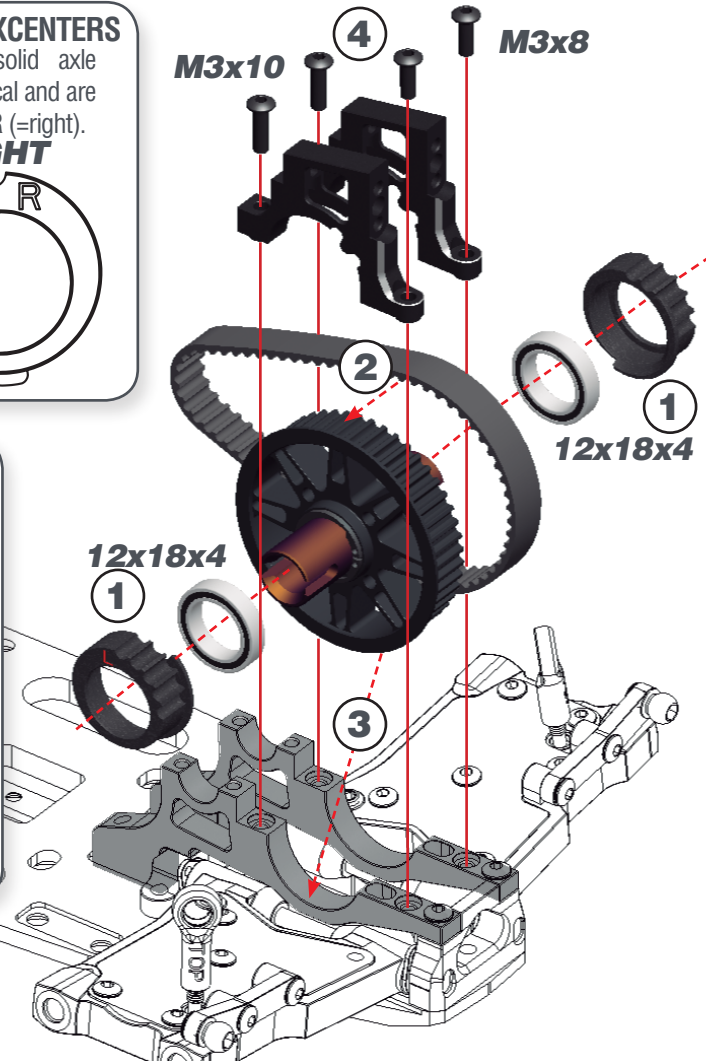

**STEP 9**

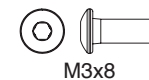
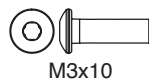
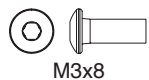
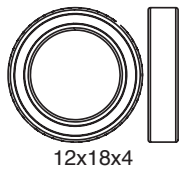
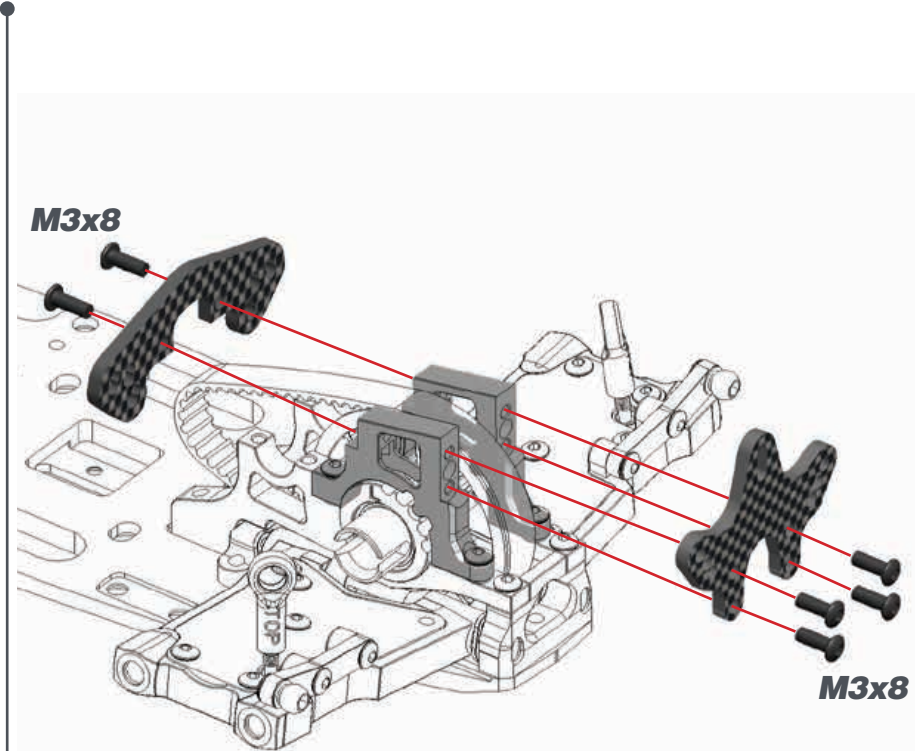



**STEP 10**

**10.1**



M3x3 (2)

! Do not tighten the M3x3 setscrews until the step 10.2

5x8x2.5 (1)

**10.2**

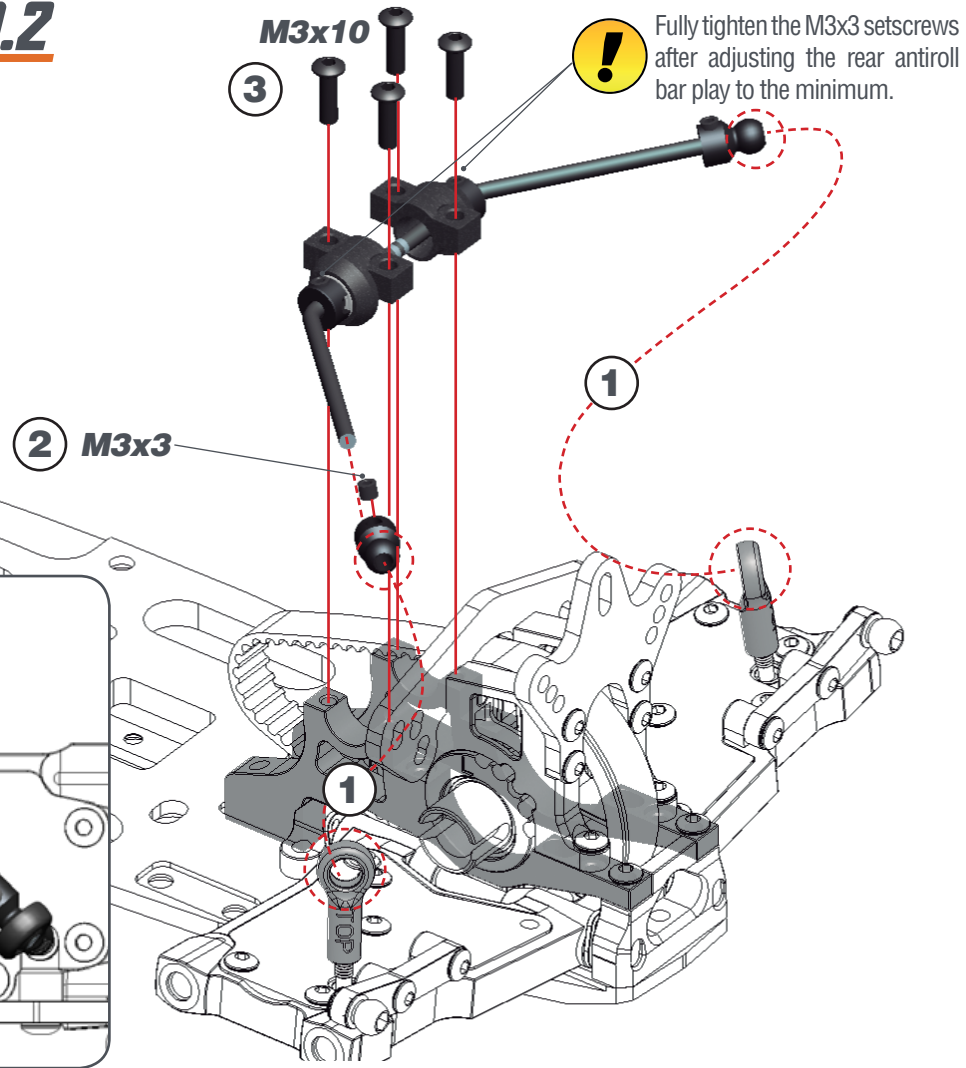

M3x10

(3)

! Fully tighten the M3x3 setscrews after adjusting the rear antiroll bar play to the minimum.

(2) M3x3

(1)

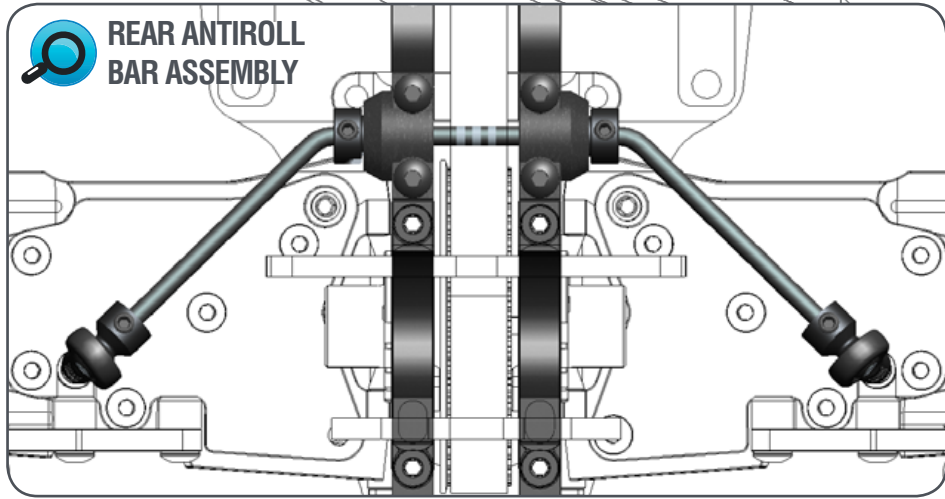

REAR ANTIROLL BAR ASSEMBLY

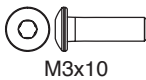

**STEP 11** **BAG 3**

**11.1**

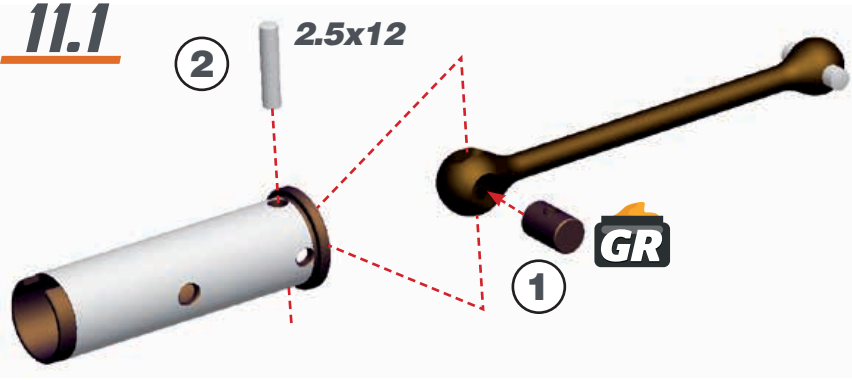

**11.2**

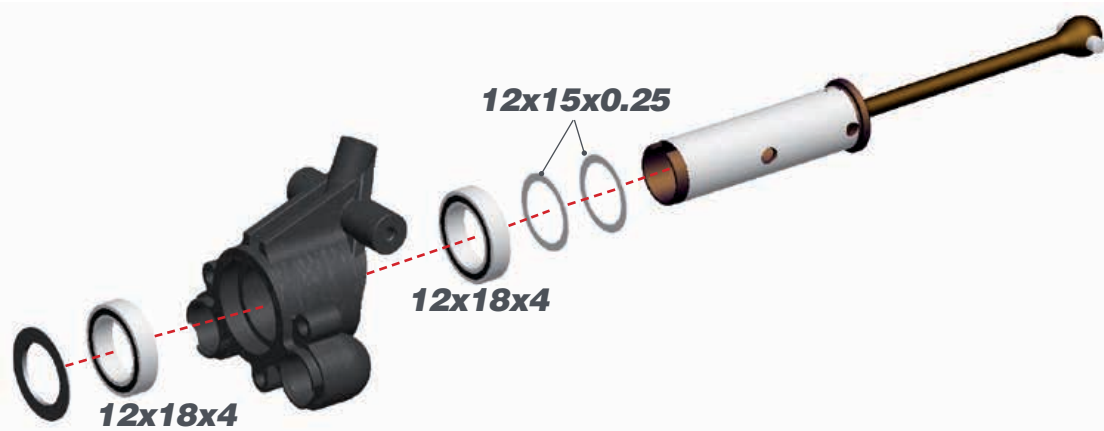

**11.3**

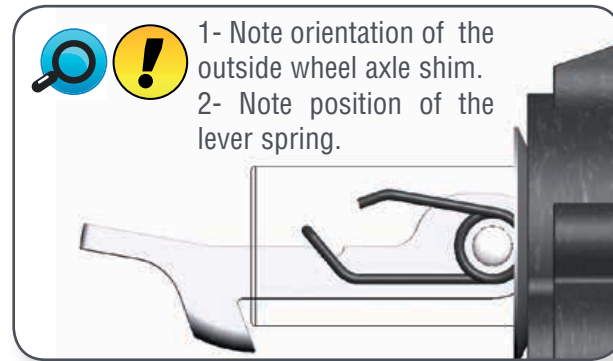
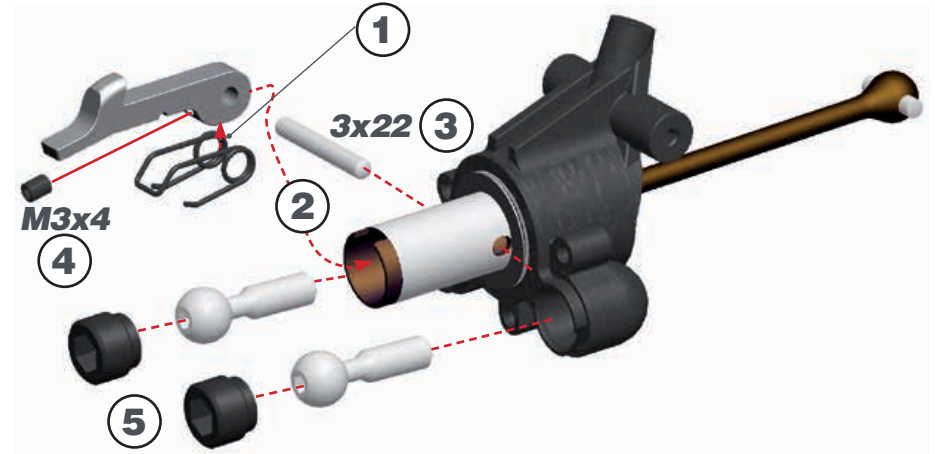

2.5x12

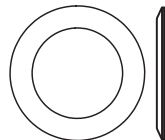

12x18x1 Conical



12x15x0.25

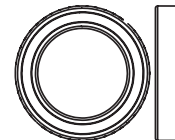

12x18x4

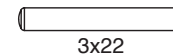

3x22



M3x4



**STEP 12**

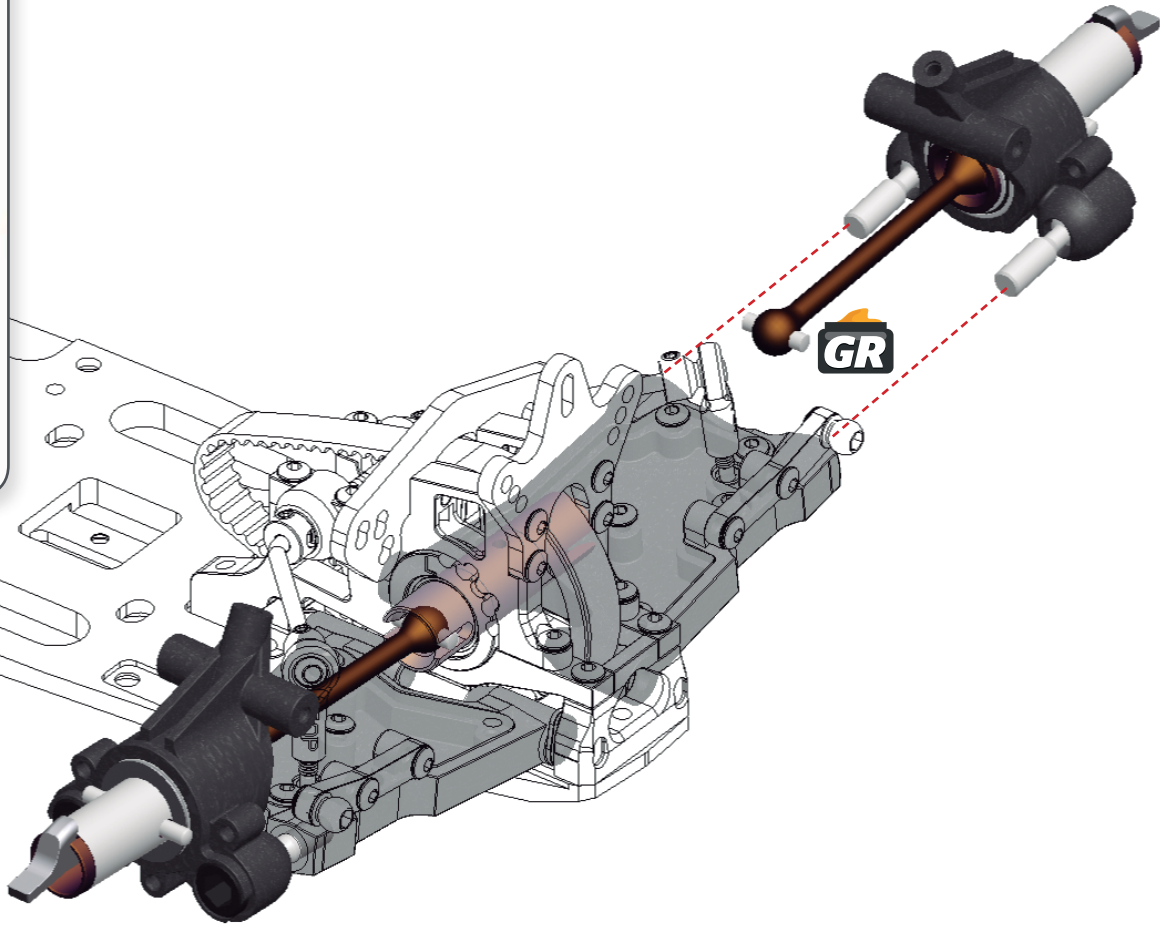
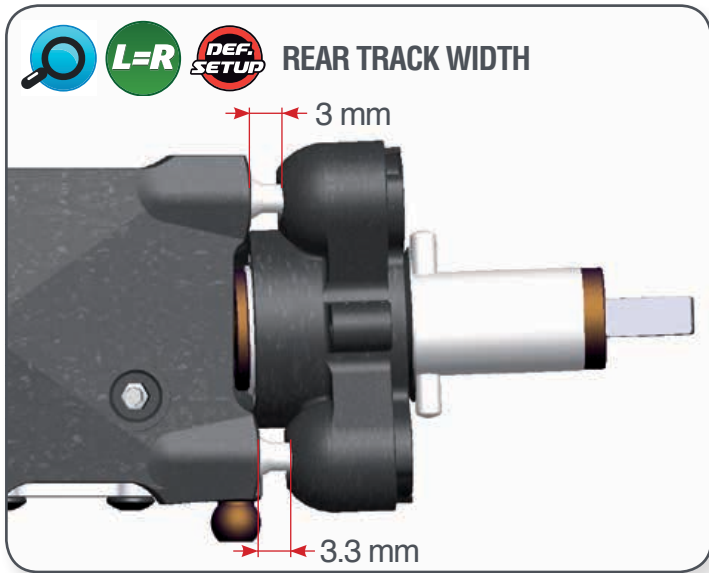

**STEP 13**

**13.1**

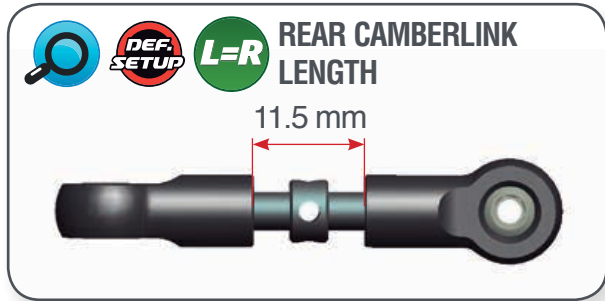

**13.2**

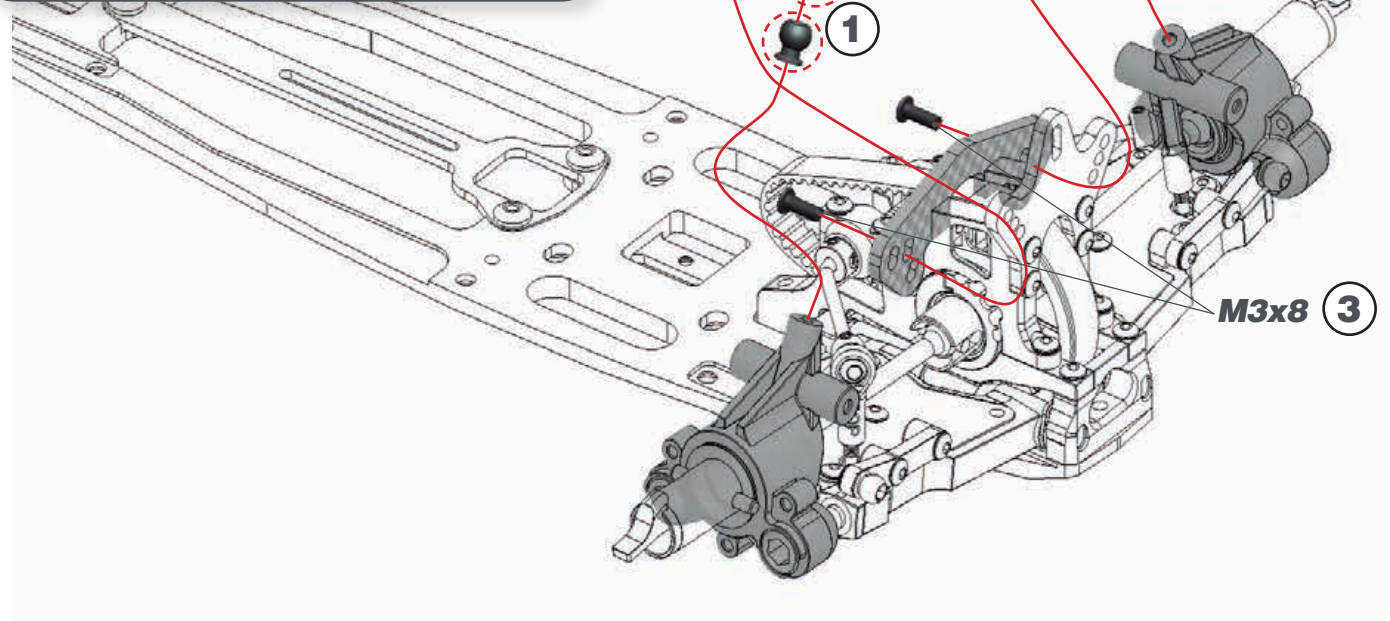
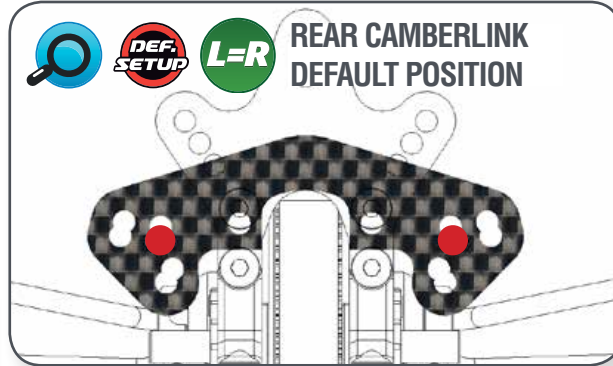



**STEP 14** **BAG 4**

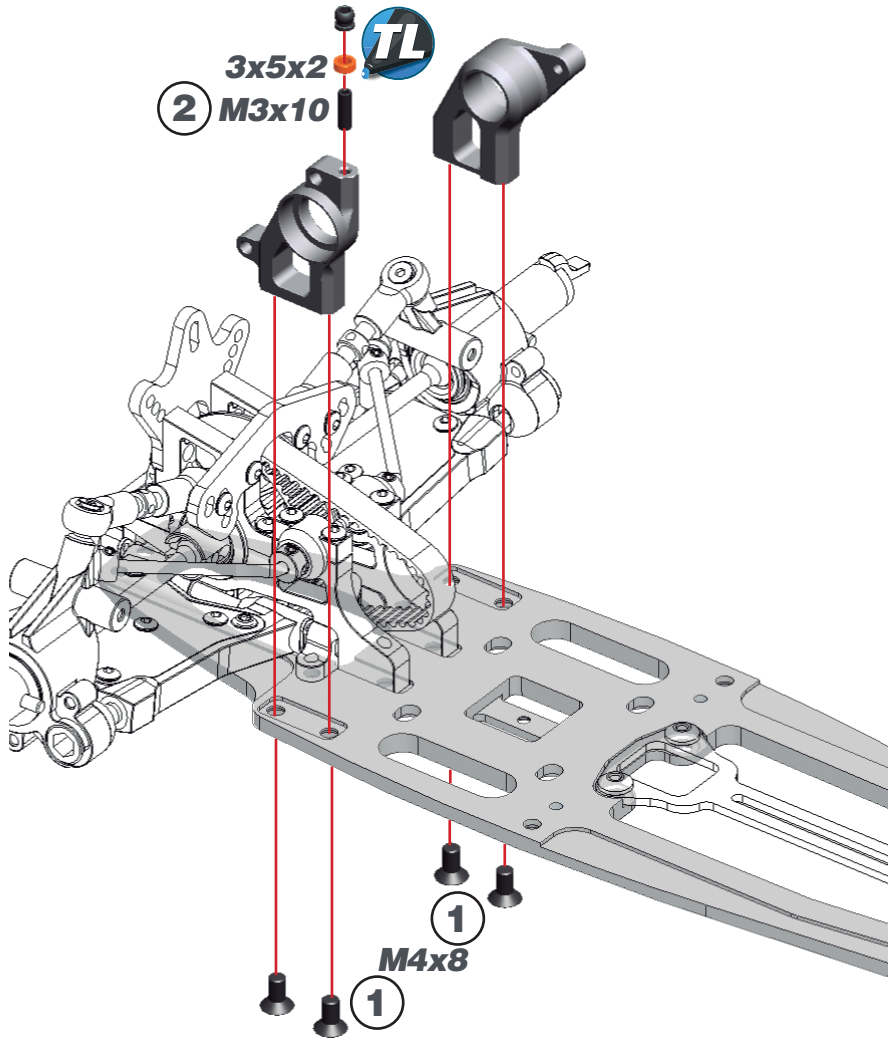

**STEP 15**

**15.1**

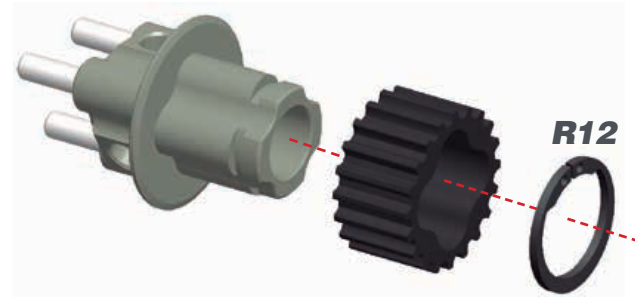

**15.2**

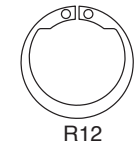
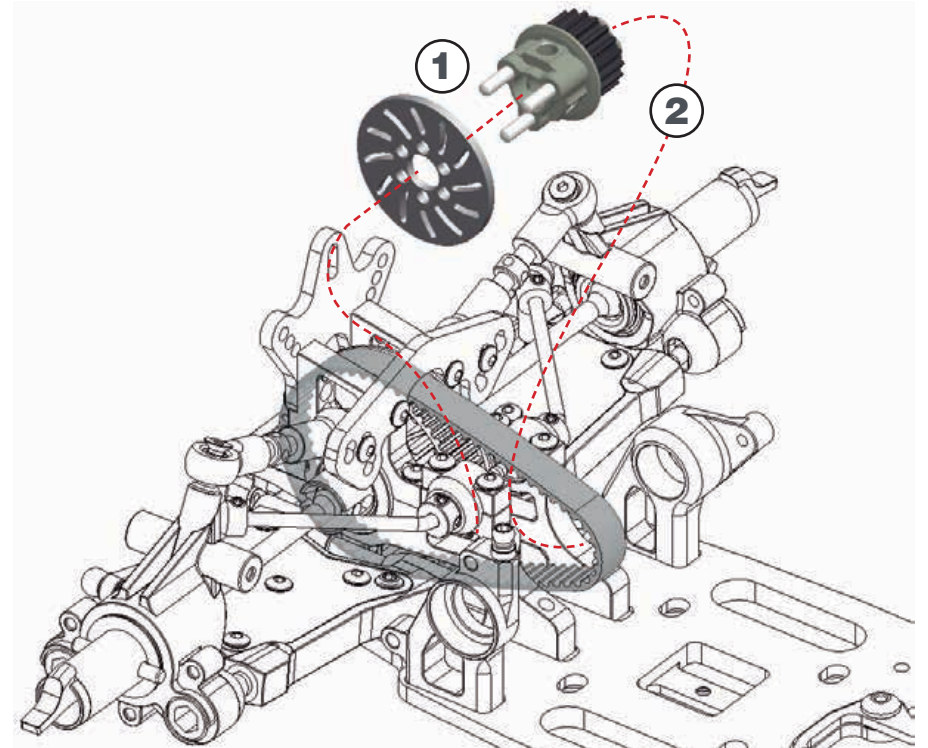

**STEP 16**

**16.1**



**16.2**

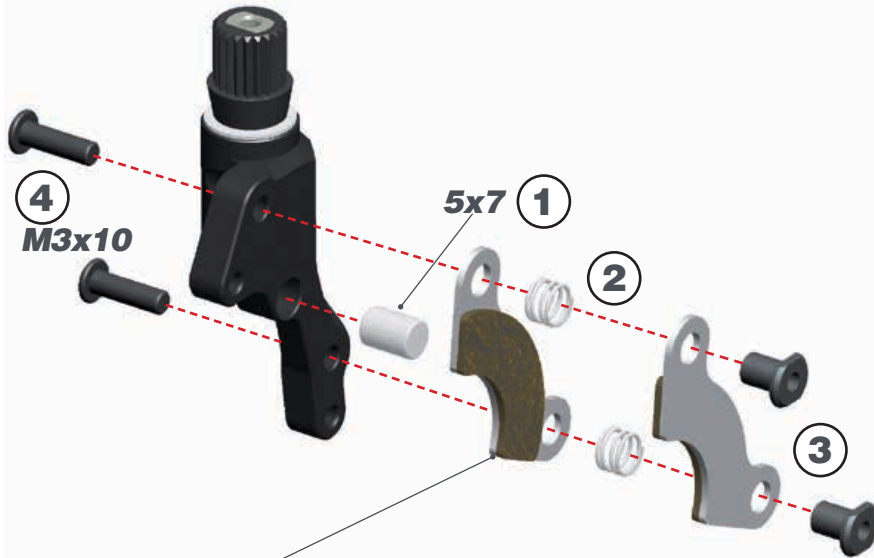

**!** After tightening the M3x10 screws check that the brake pads slide easy over the bushings.

**16.3**

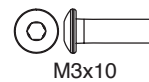
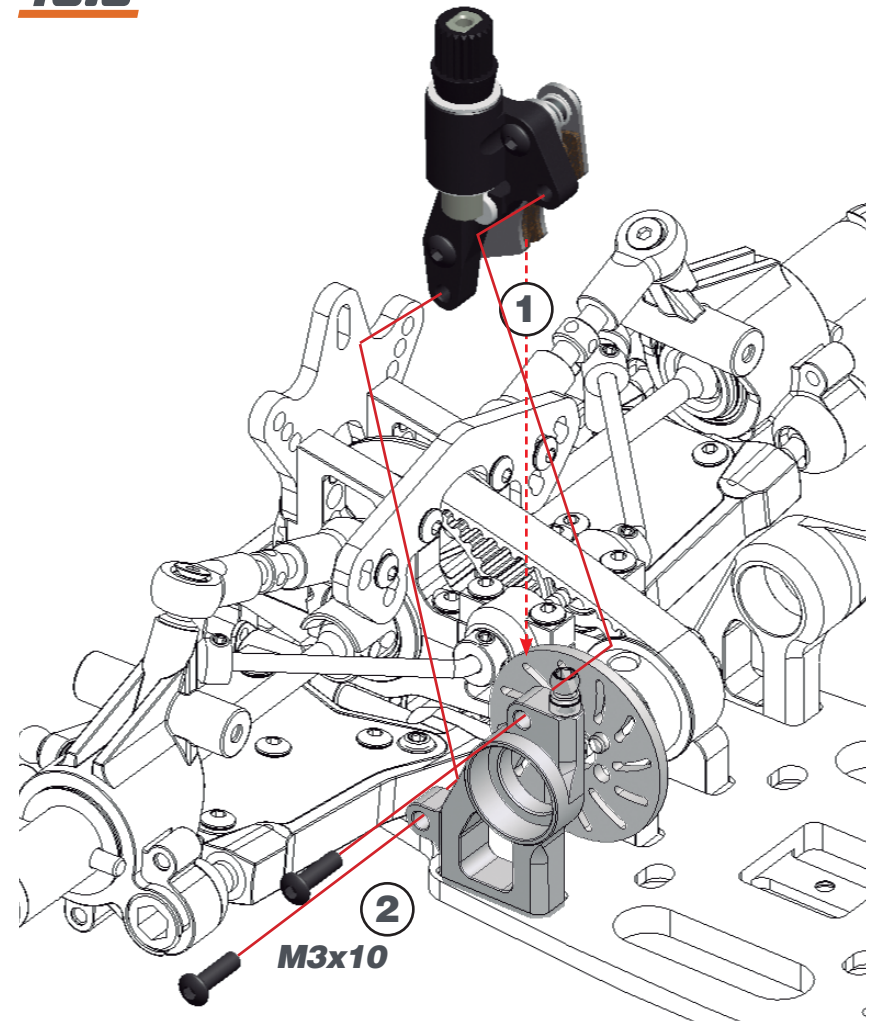

**STEP 17** **BAG 5**

**17.1**

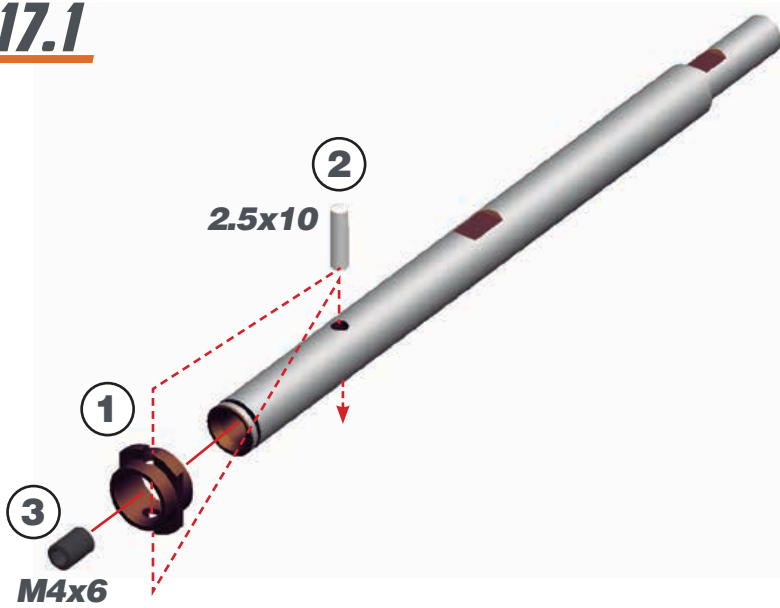

**17.2**

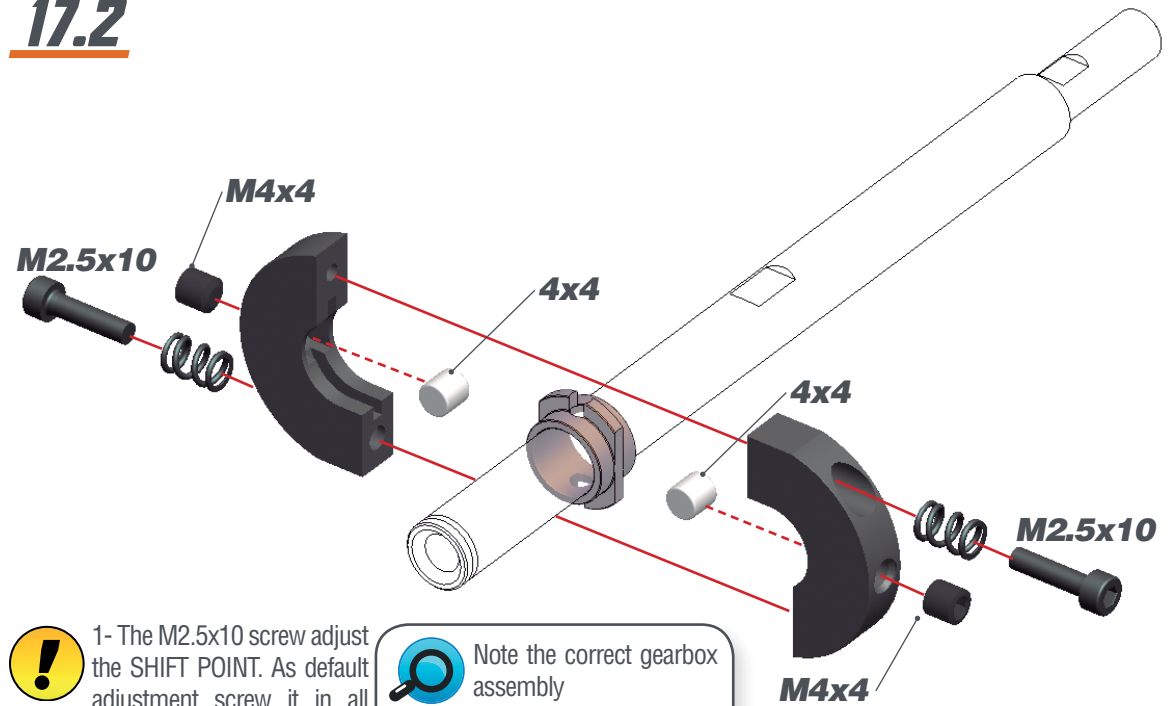

**!** 1- The M2.5x10 screw adjust the SHIFT POINT. As default adjustment screw it in all the way (do not overtighten to avoid spring deformation), then unscrew 3 turns.

2- Adjust the M4x4 screw to minimise the gap between the shoes and the bell, but still spinning free without touching. Check after each run.

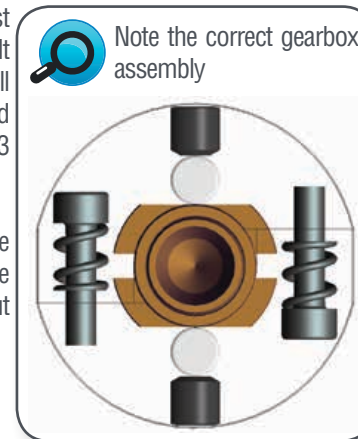



**STEP 17**

**17.3**

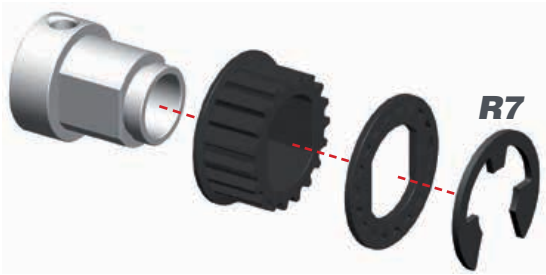

**17.4**



Adjust the position of the side pulley to have a little play on the 2-speed shaft.

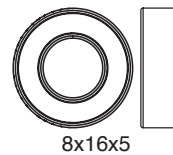
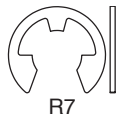
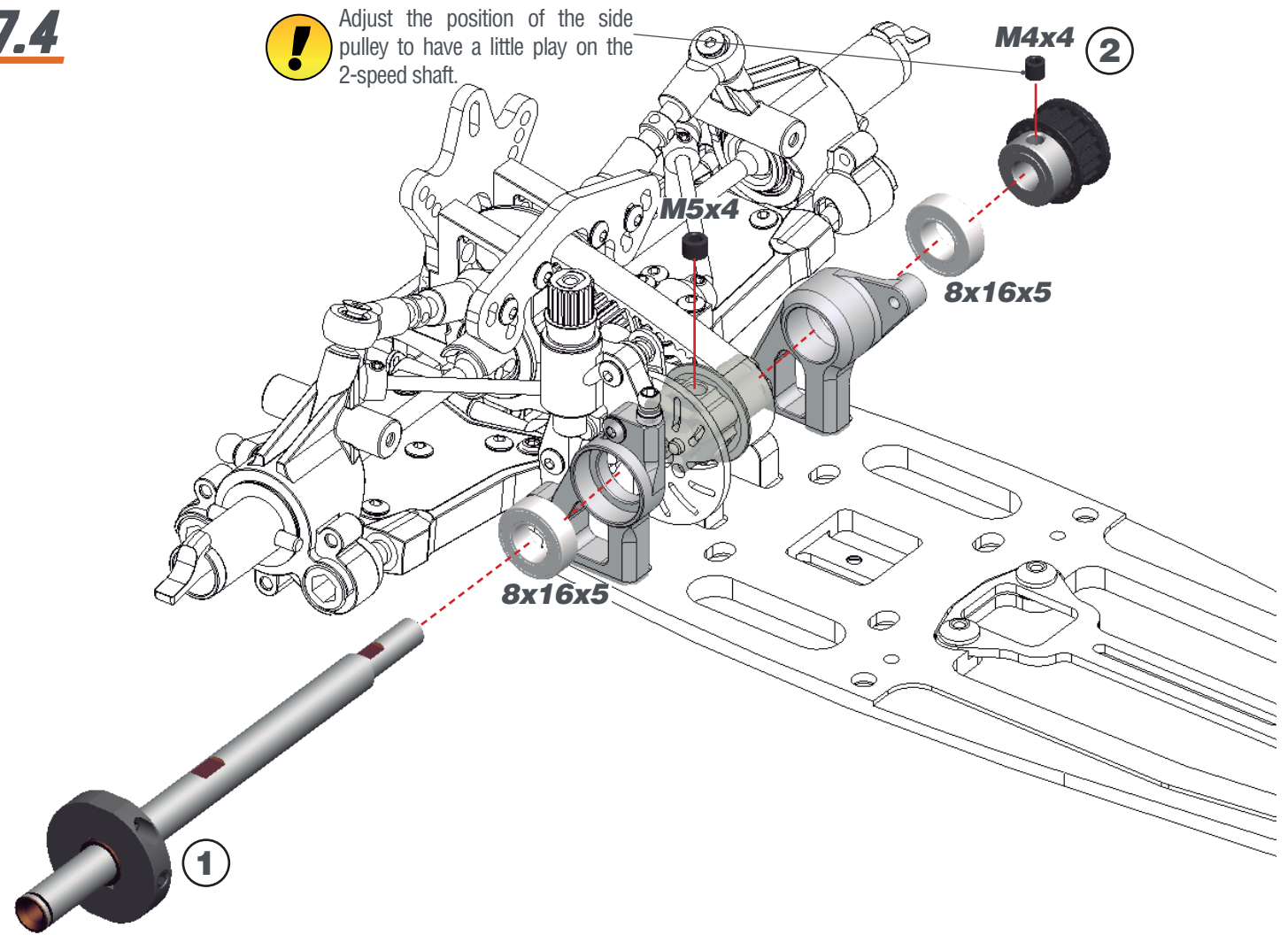

## STEP 18

**18.1**

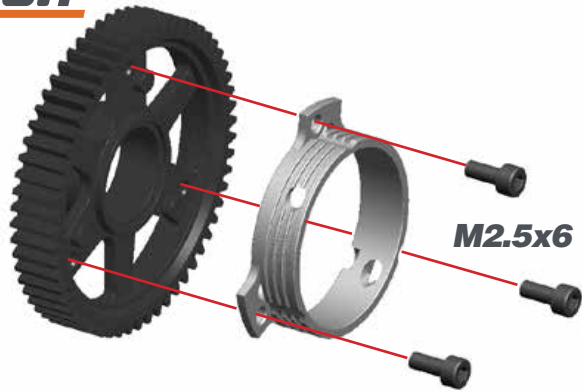

**18.2**

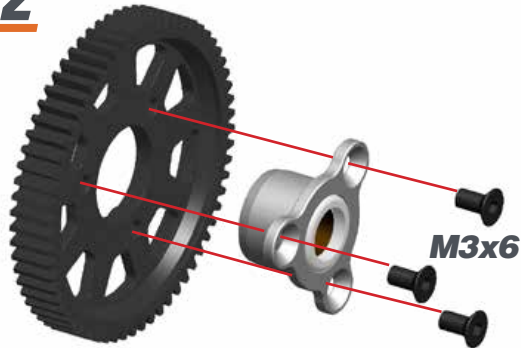

**18.3**

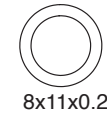
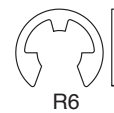
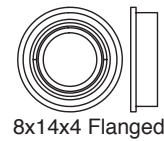
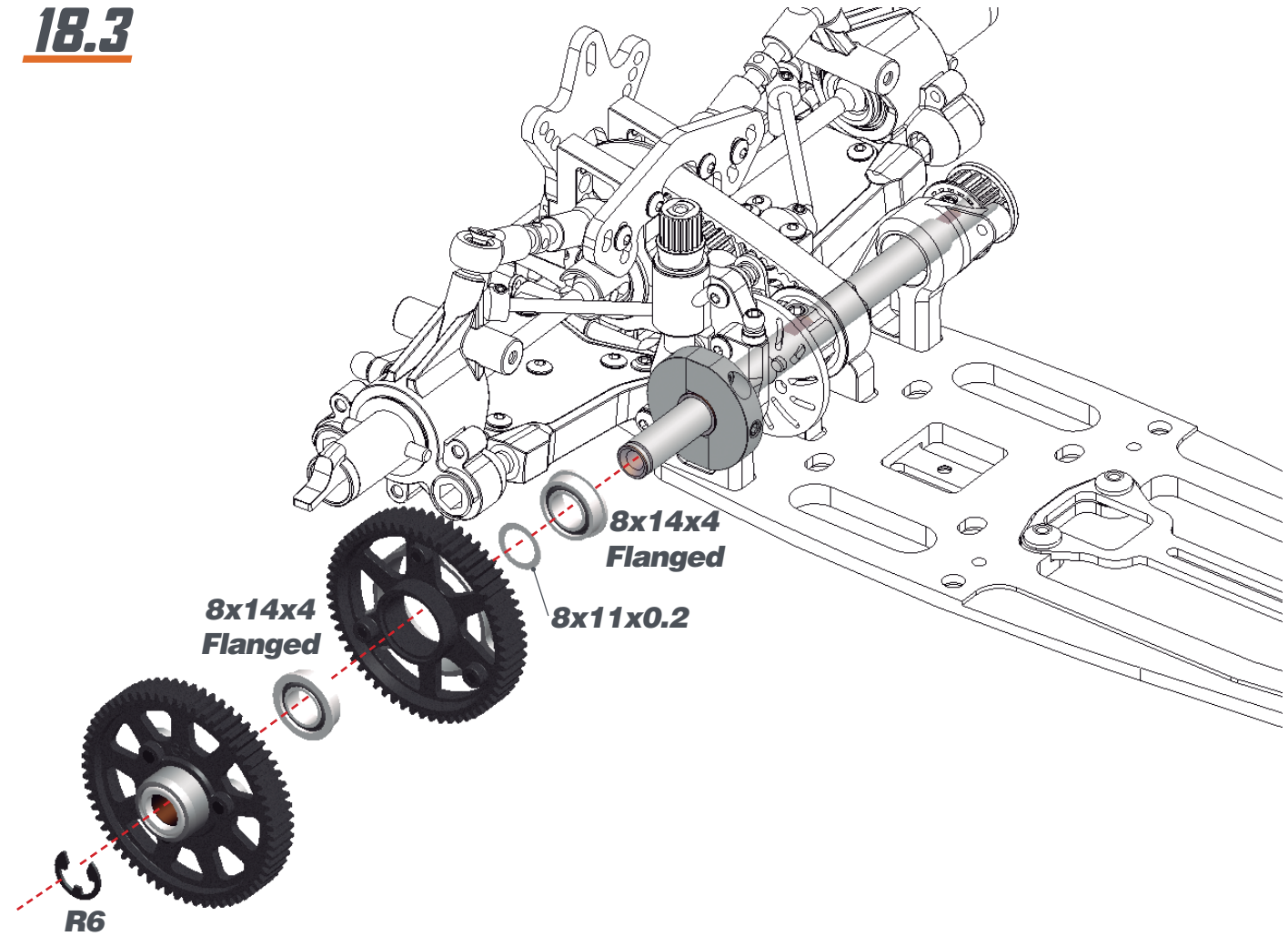

## STEP 19 **BAG 6**

## STEP 20

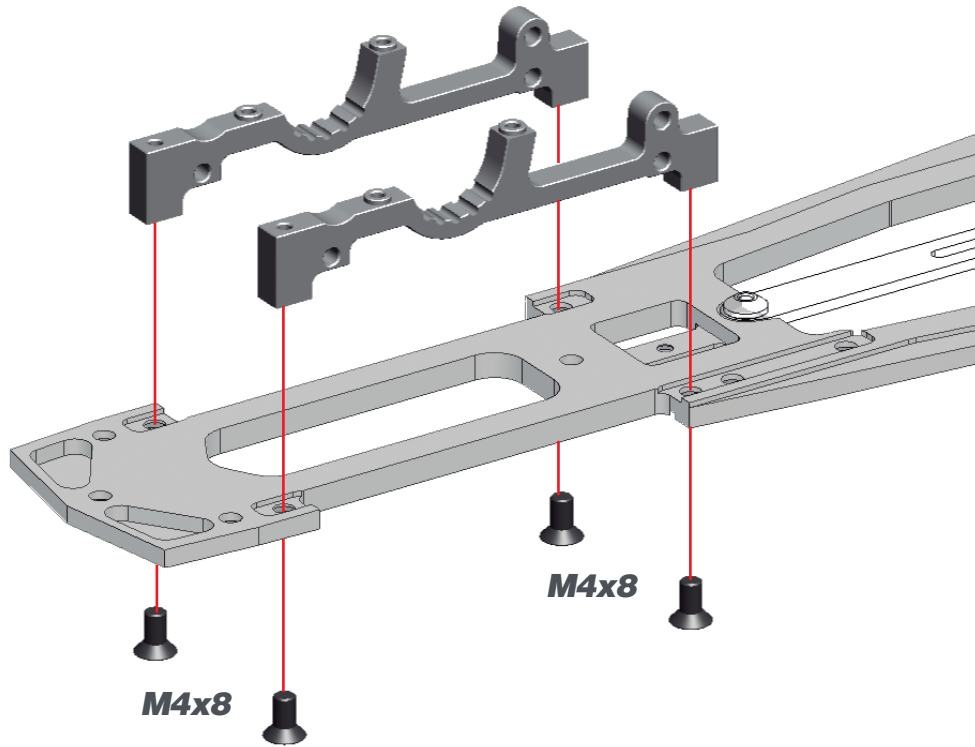

M4x8

### 20.1



### 20.2

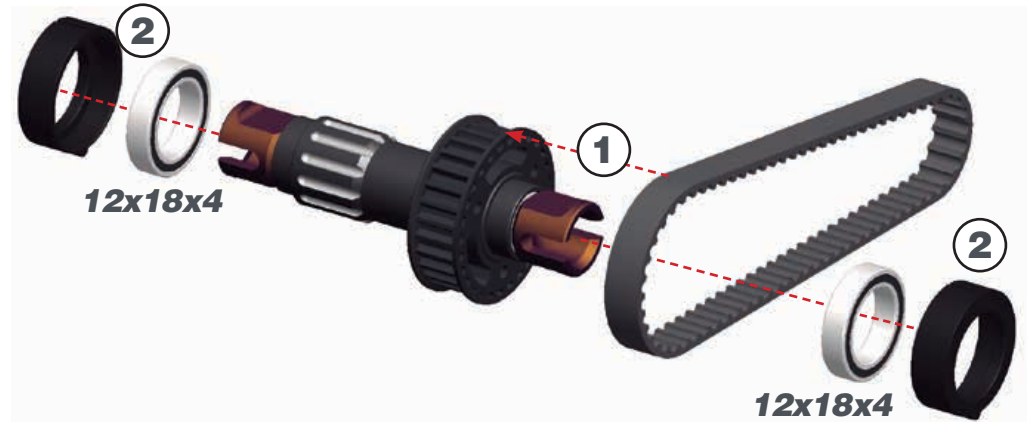

M2.5x6

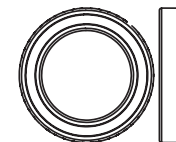

12x18x4



**STEP 21**

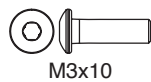
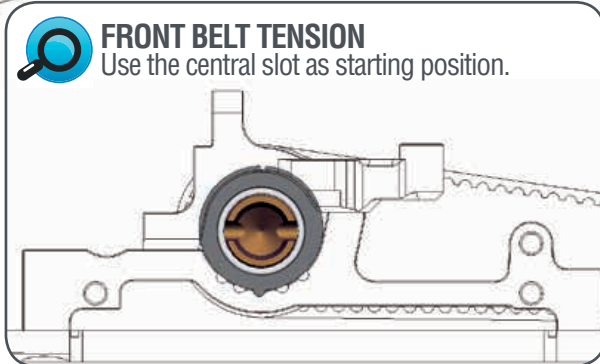
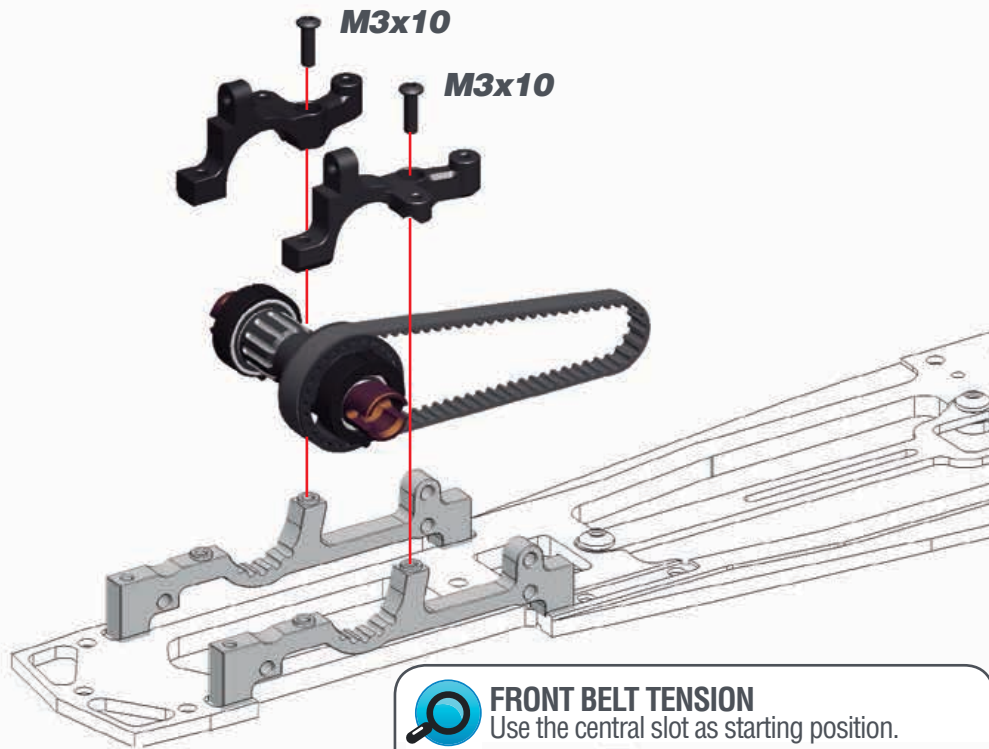

**STEP 22**

**22.1**



**22.2**

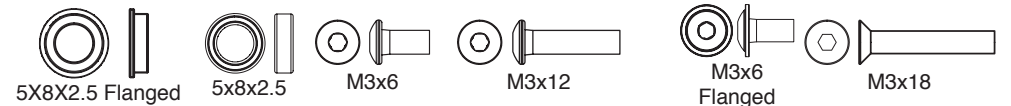
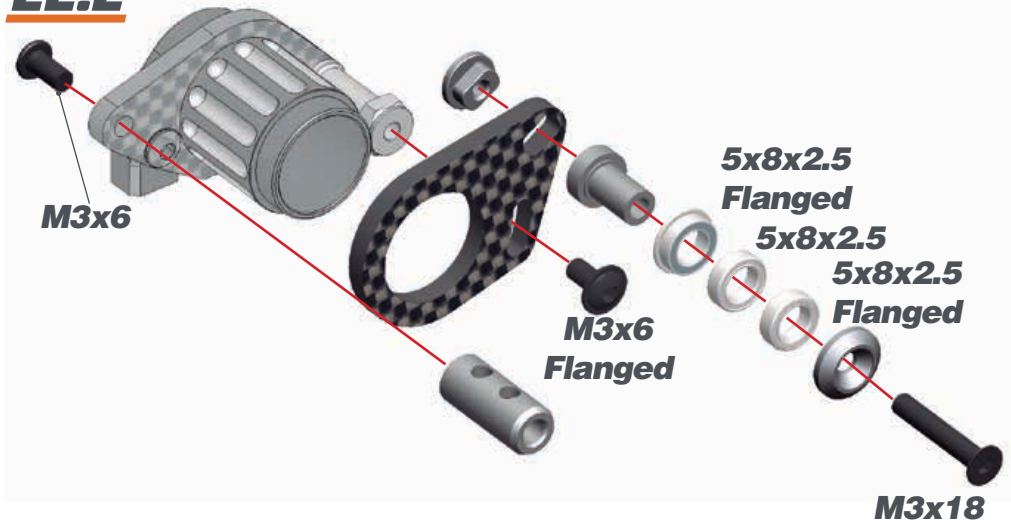

**STEP 22**

**22.3**

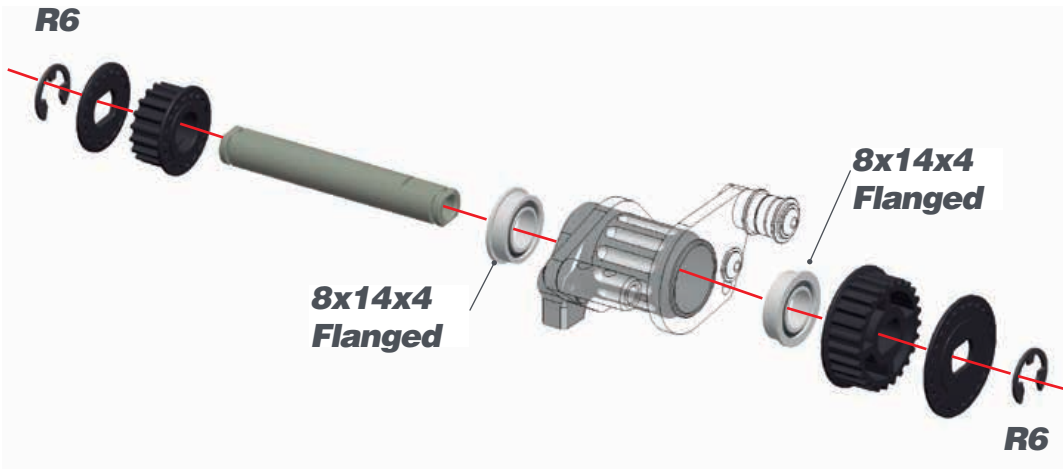

**22.4**

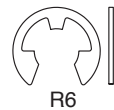
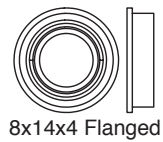
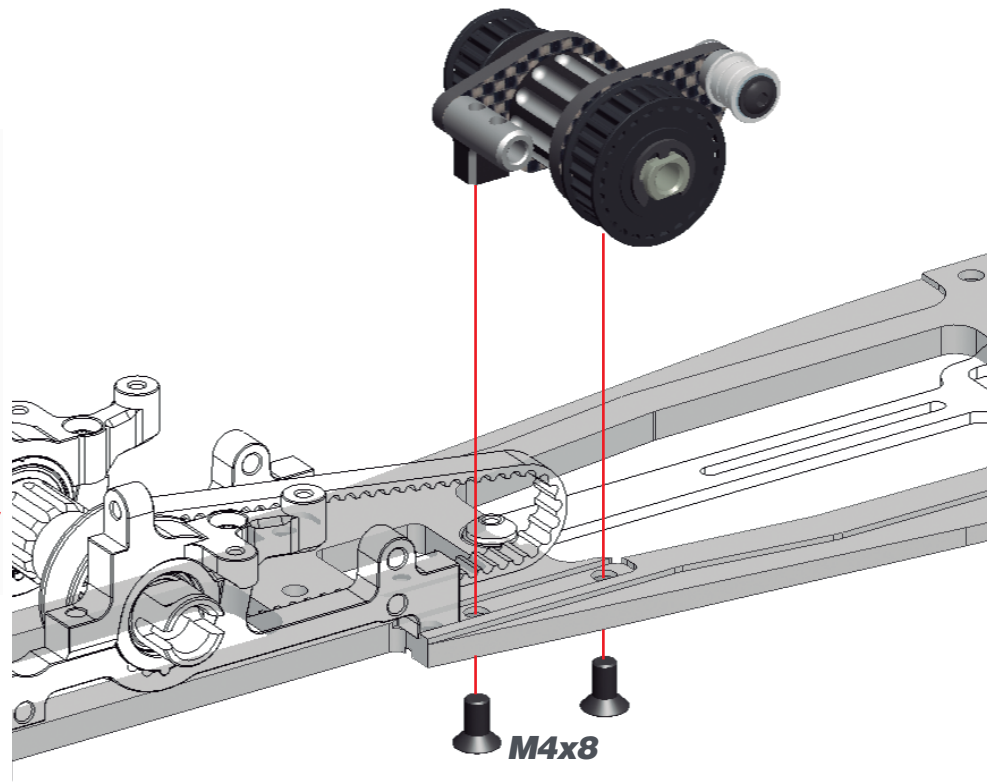

**STEP 23** **BAG 7**

**23.1**

L=R



**23.3**

L=R

Serpent 989 allows to move front bottom arms 3 mm in (NARROW) and out (WIDE). To maintain the same shock angle, use the suspension bracket and shock bracket as shown here.

**NARROW**

**WIDE**

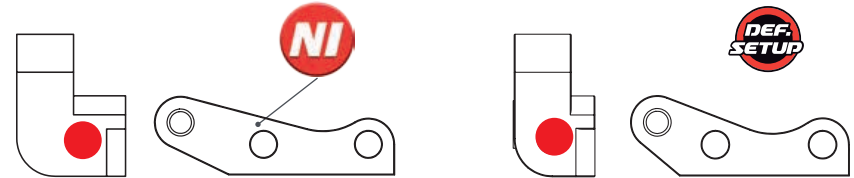

**23.2**

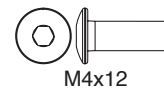
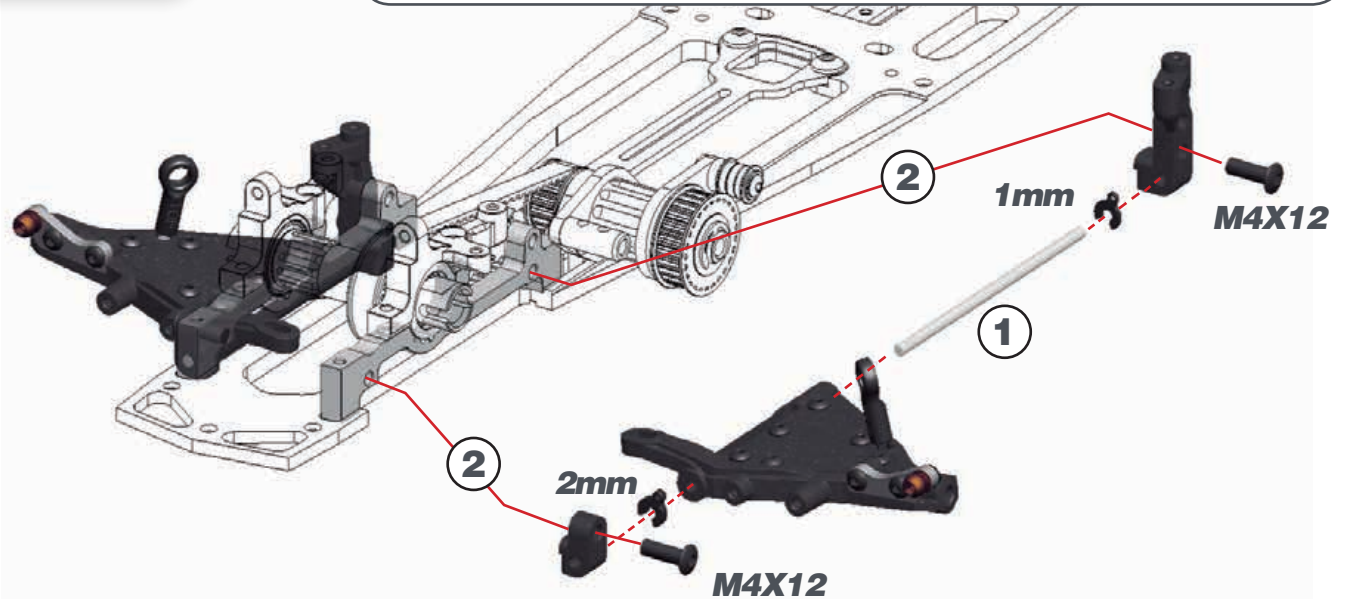



**STEP 24**

**24.1**



**FRONT DOWN STOPS**

**DEF. SETUP** **L=R**

3.3 mm

**24.2**



**24.3**

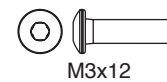
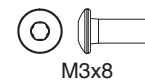
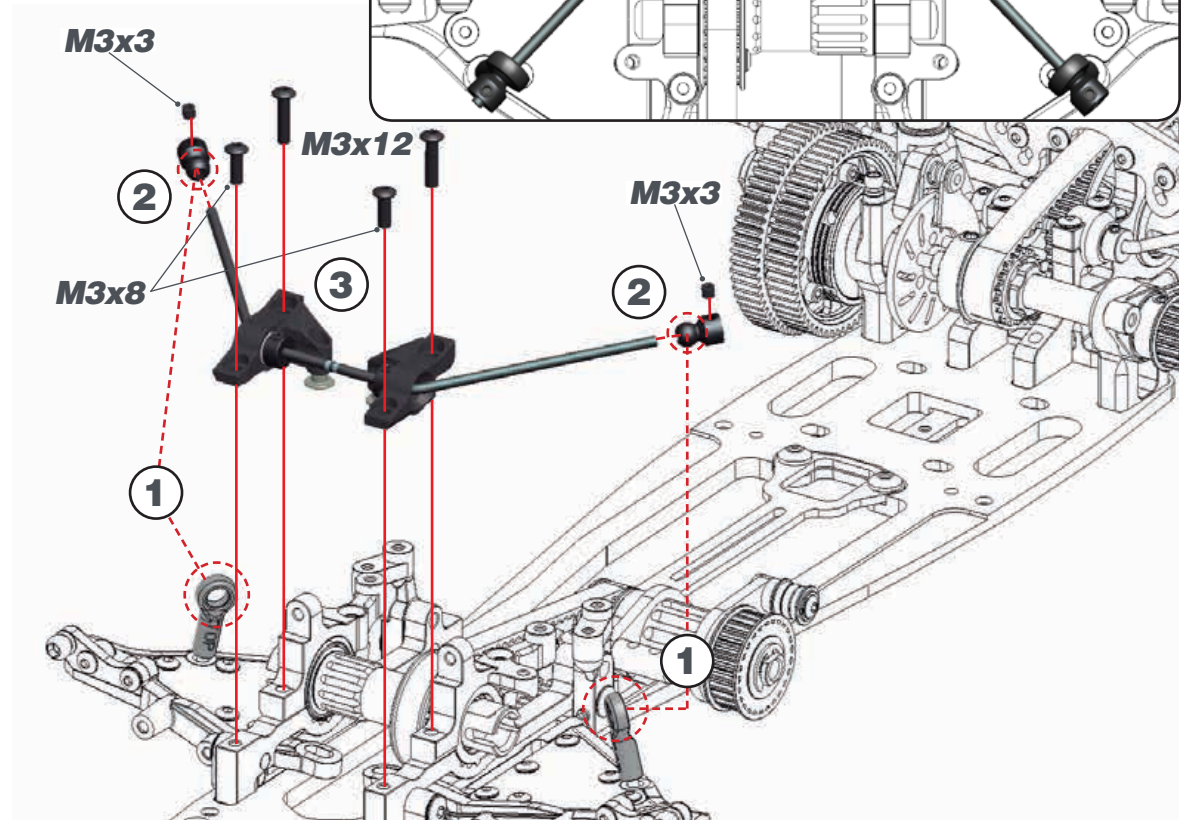
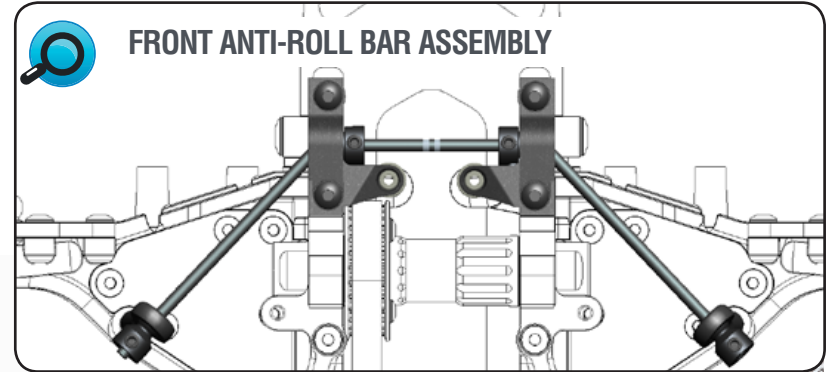

**STEP 25** **BAG 8**

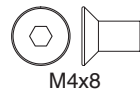
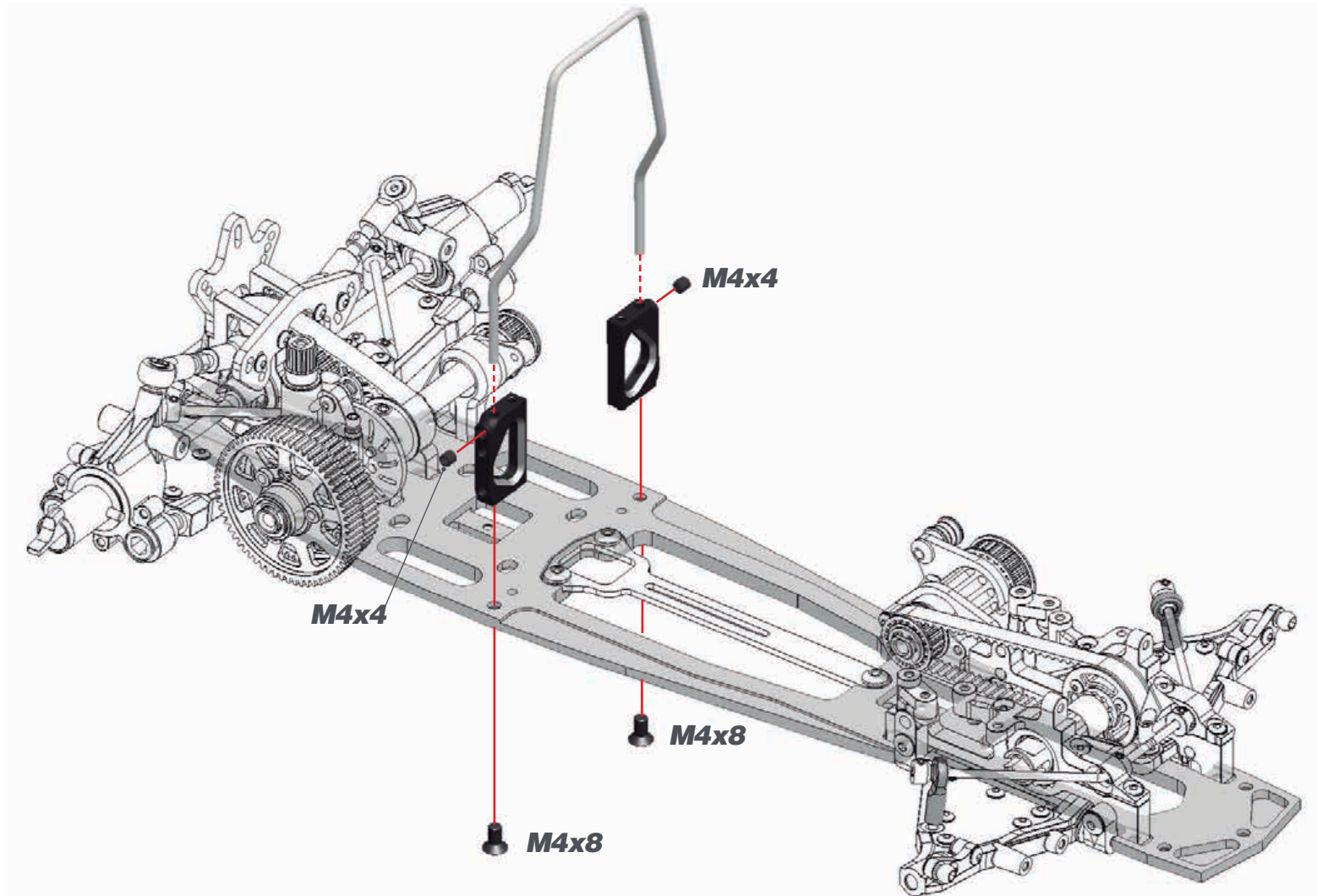

**STEP 26**



M3x6



Nylock nut  
M3

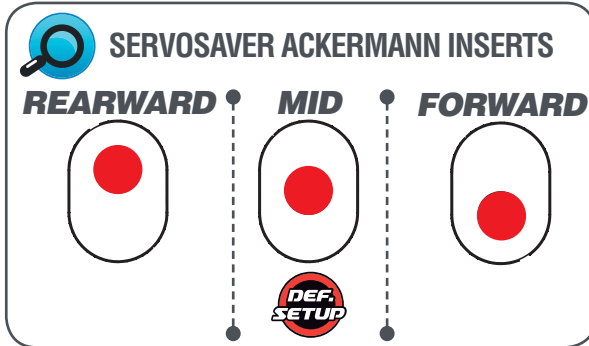

Preload the servo-saver-spring 1mm.

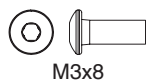
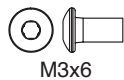
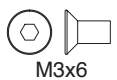
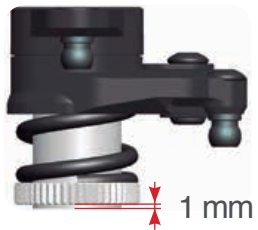

**STEP 27**

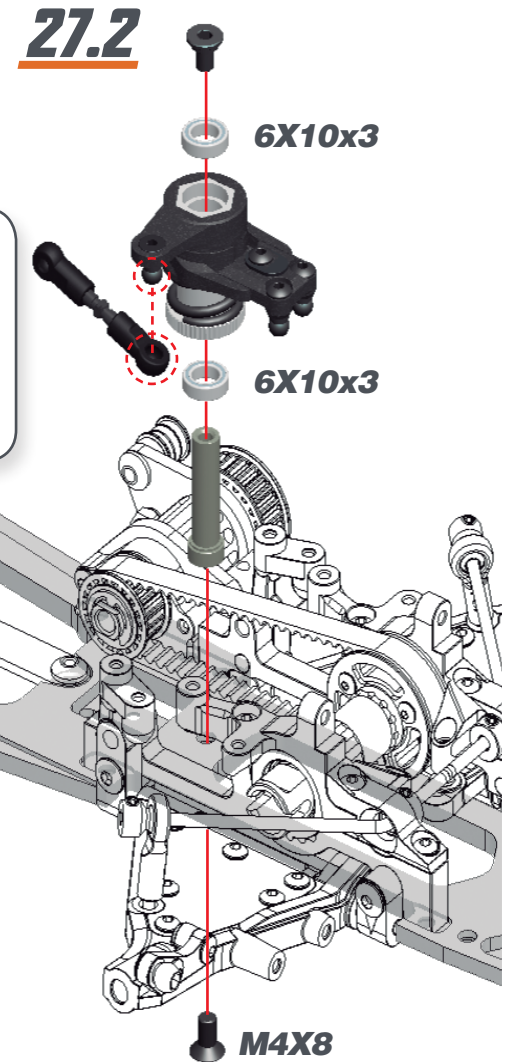

6X10x3

6X10x3

M4X8





## STEP 28 **BAG 9**

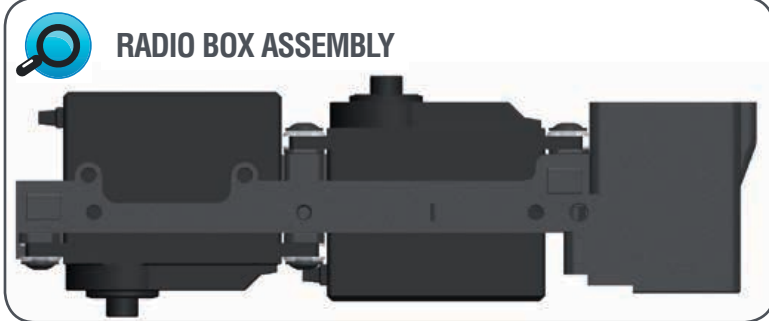
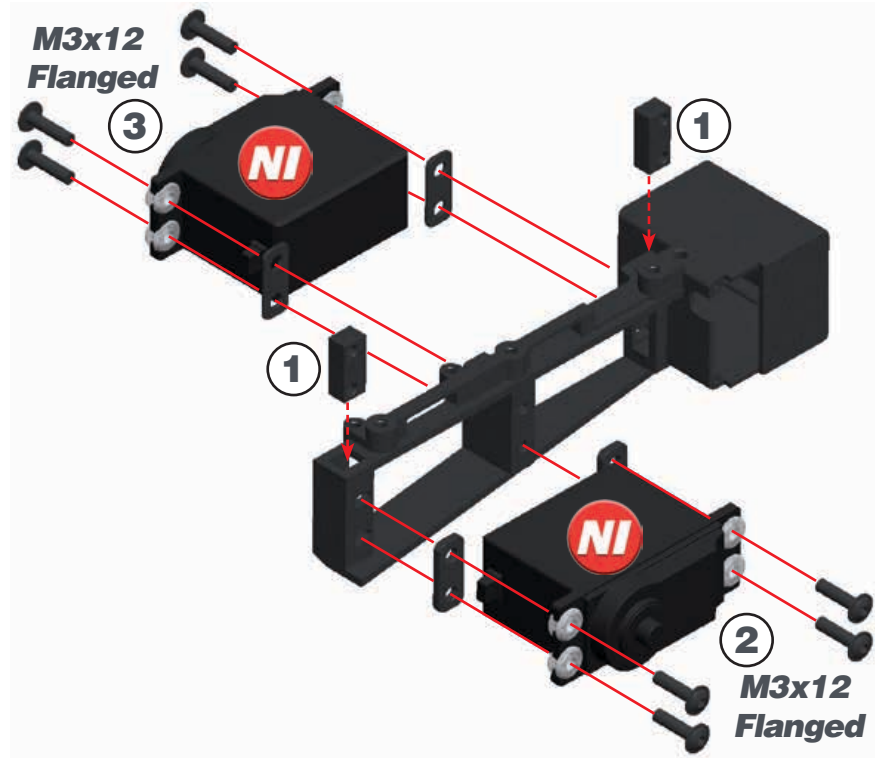

## STEP 29

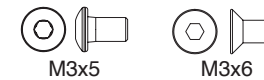
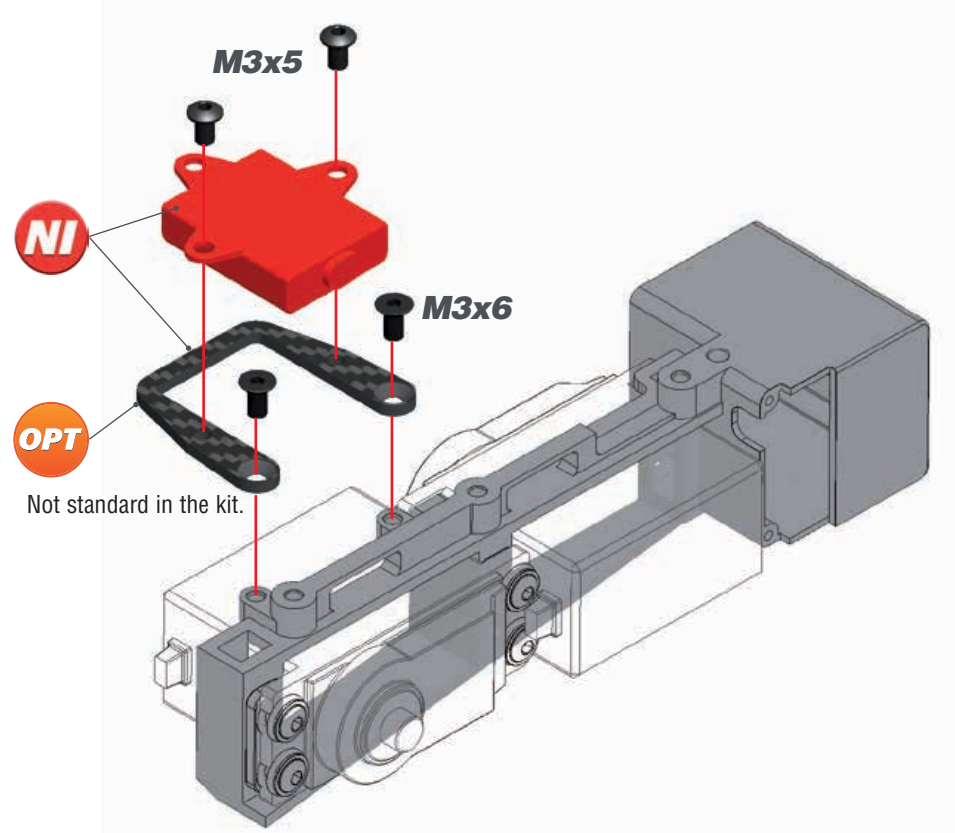

**STEP 30**

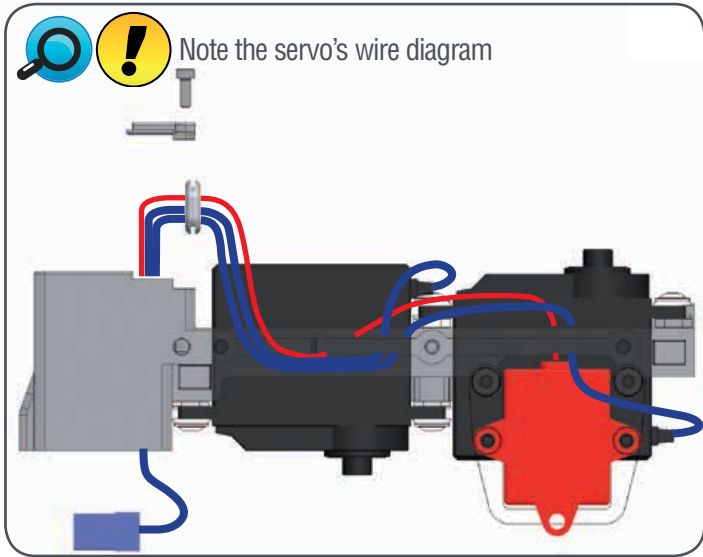
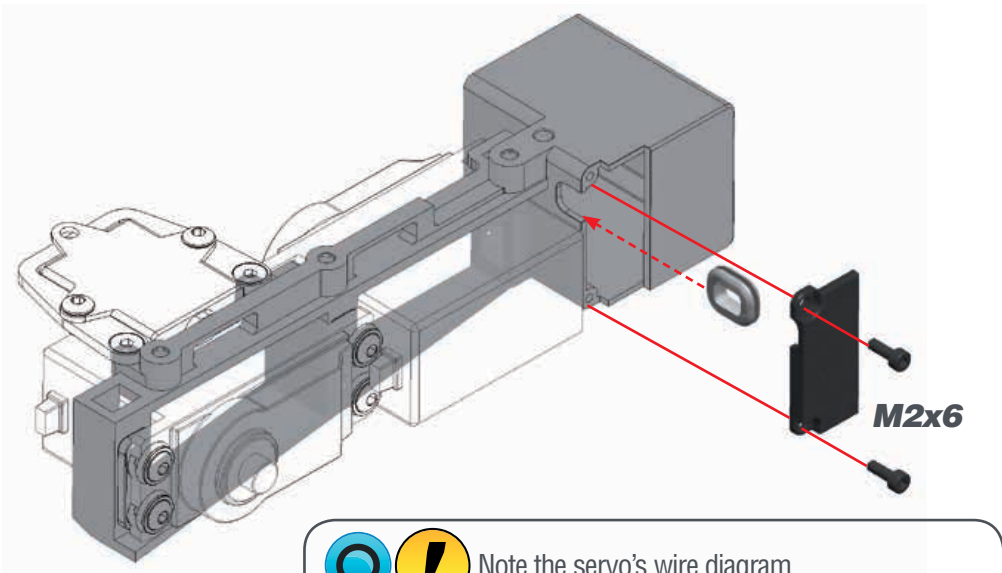

M2x6

**STEP 31**

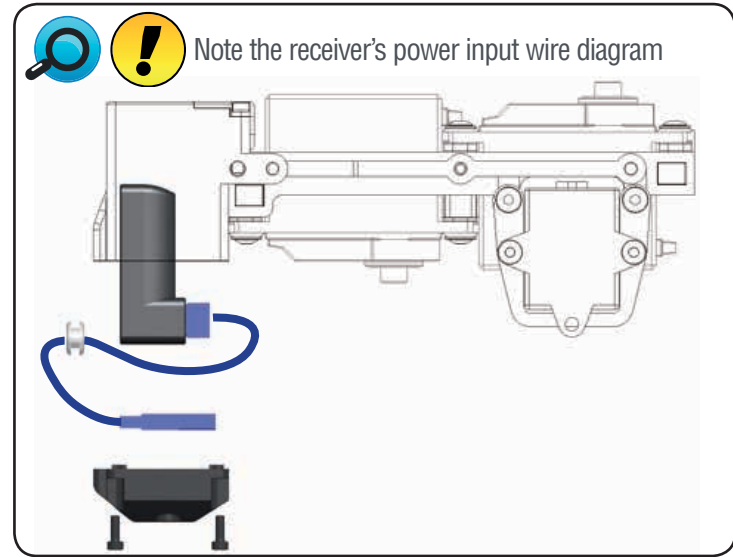
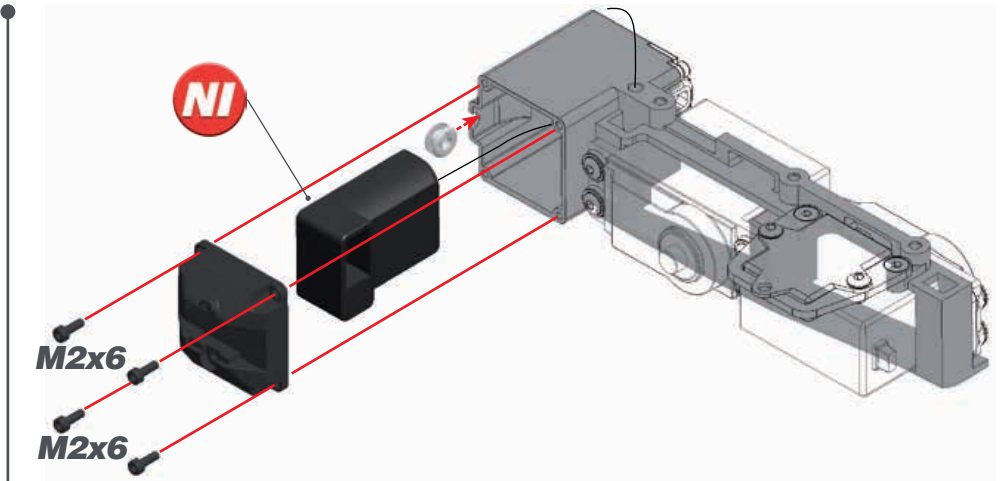

M2x6

**STEP 32**

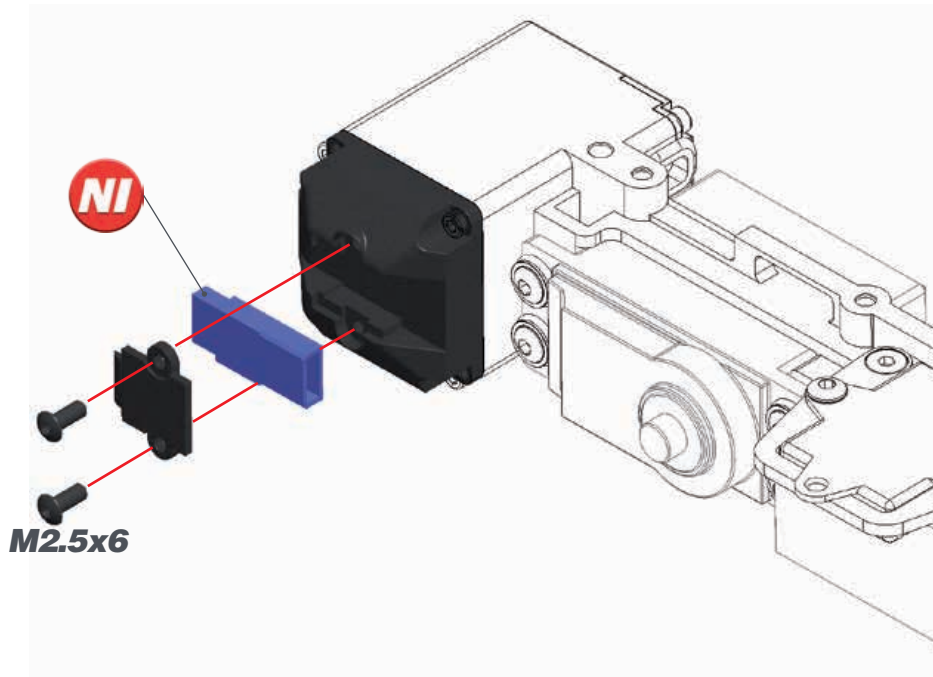

**STEP 33**

**!** Check how many teeth your servo spline has (23, 24 or 25) and use the right lever.

**!** Note correct pivot ball type.



**!** Note correct pivot ball type.

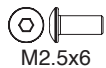
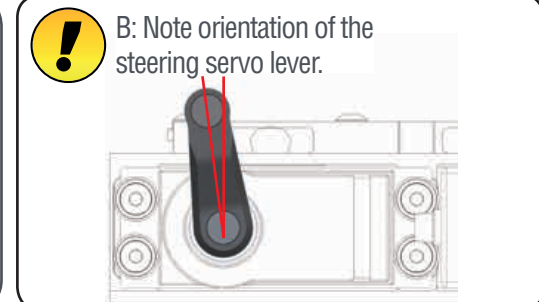
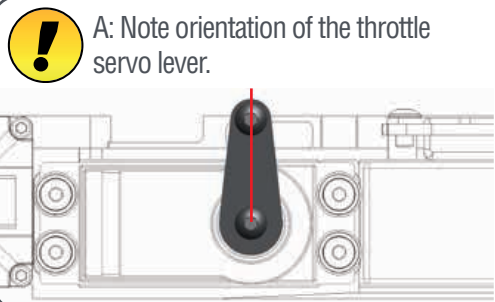
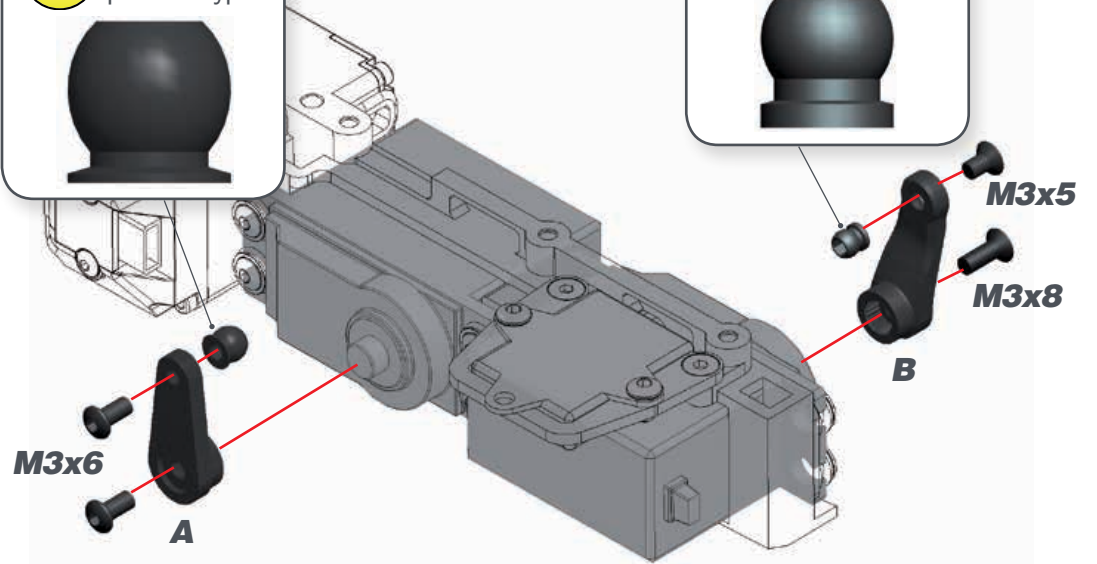



**STEP 34**

**34.1**  Check how many teeth your servo spline has (23, 24 or 25) and use the right lever.



**34.2**

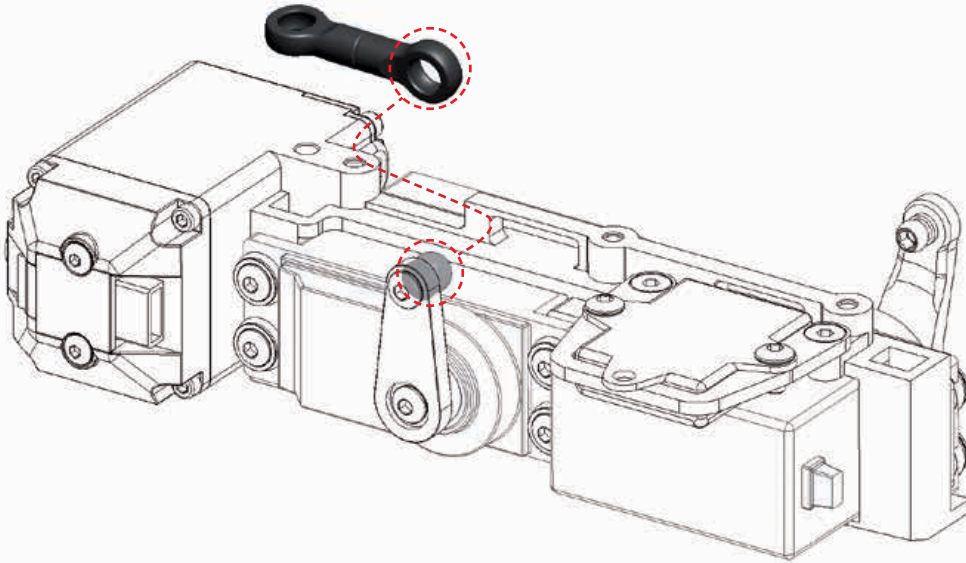

**STEP 35** **BAG 10**

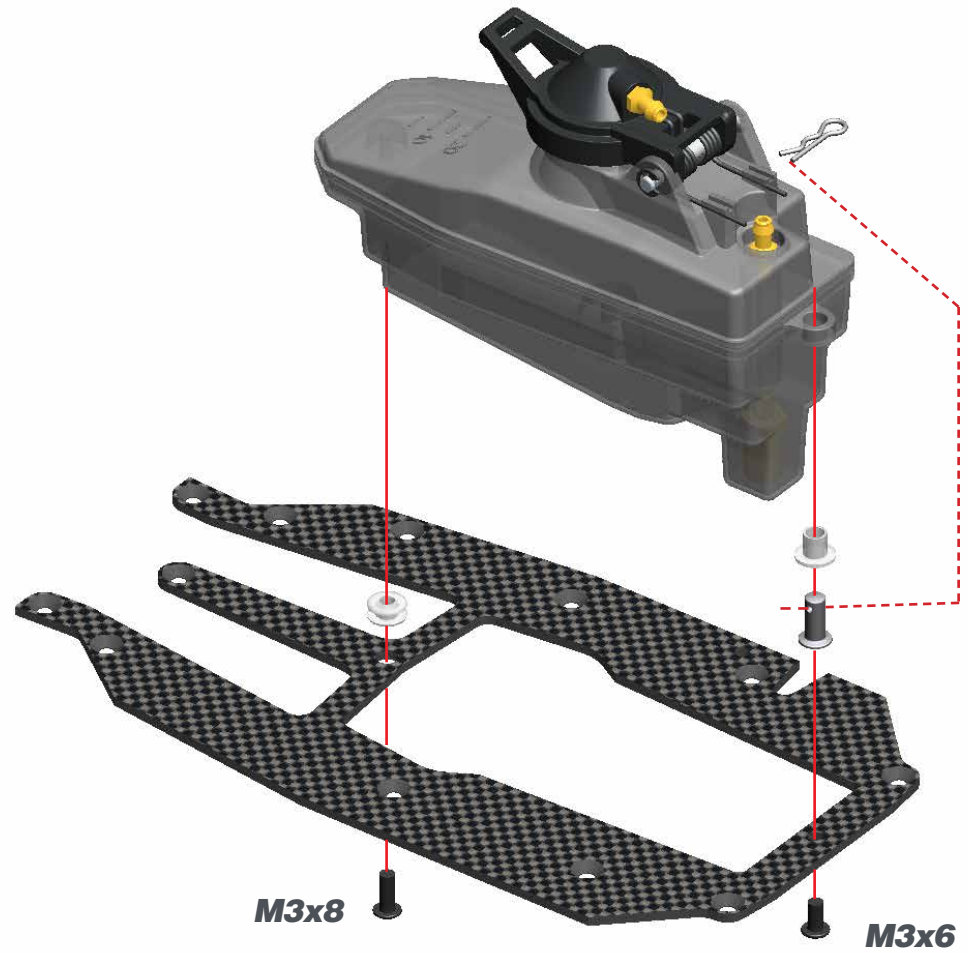

**STEP 36**

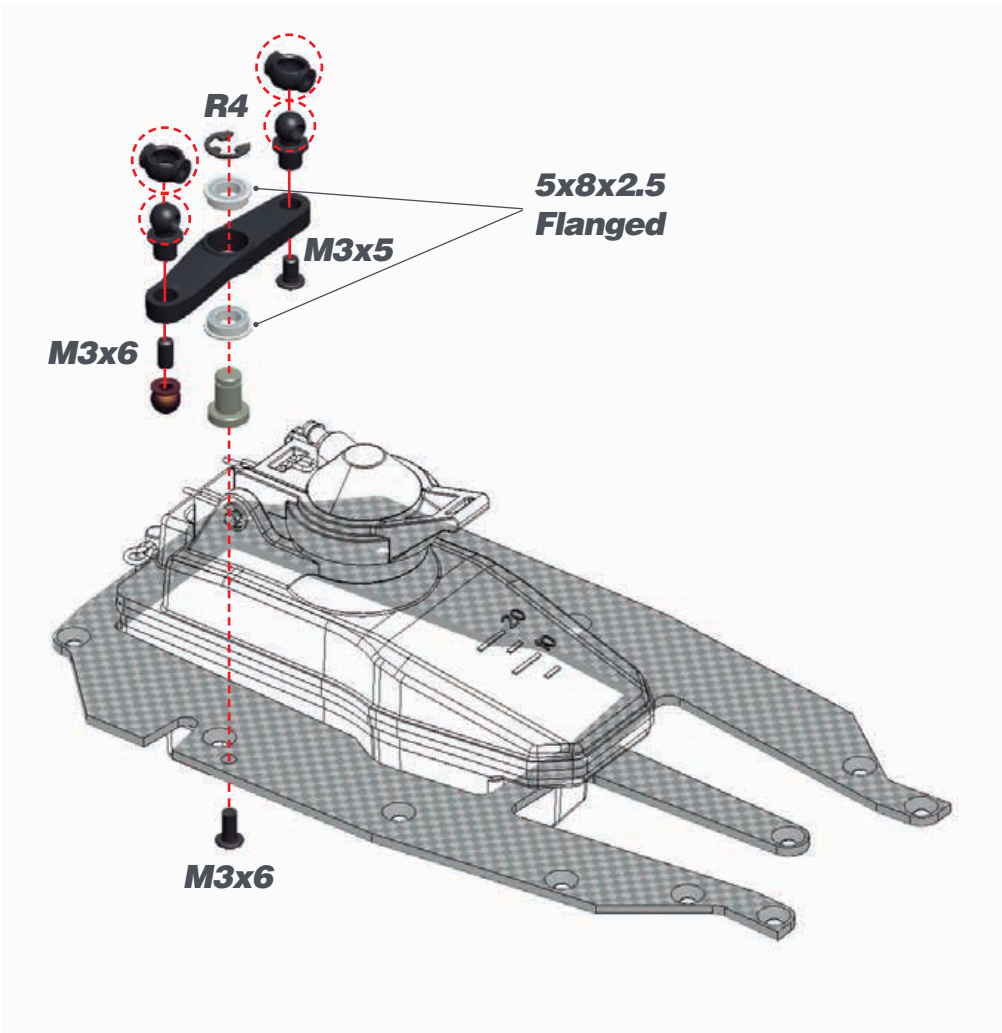

**STEP 37**

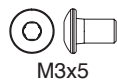
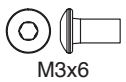
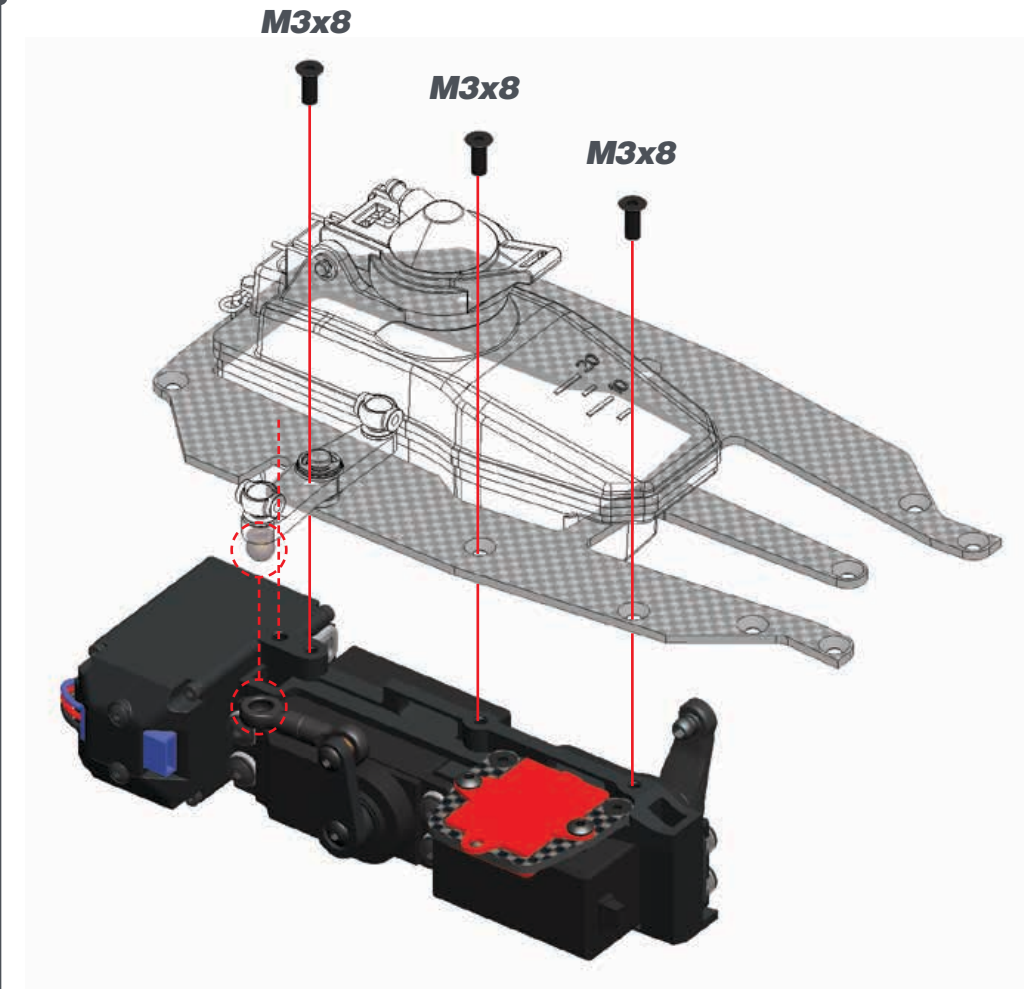

**STEP 38**

**38.1**

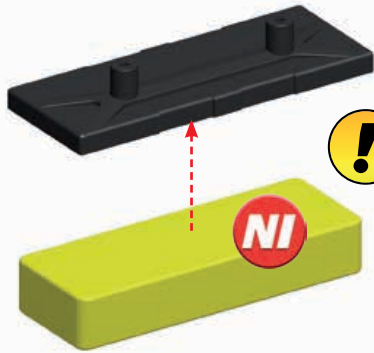

**!** Use tape to mount the battery to the plastic support.

**38.2**

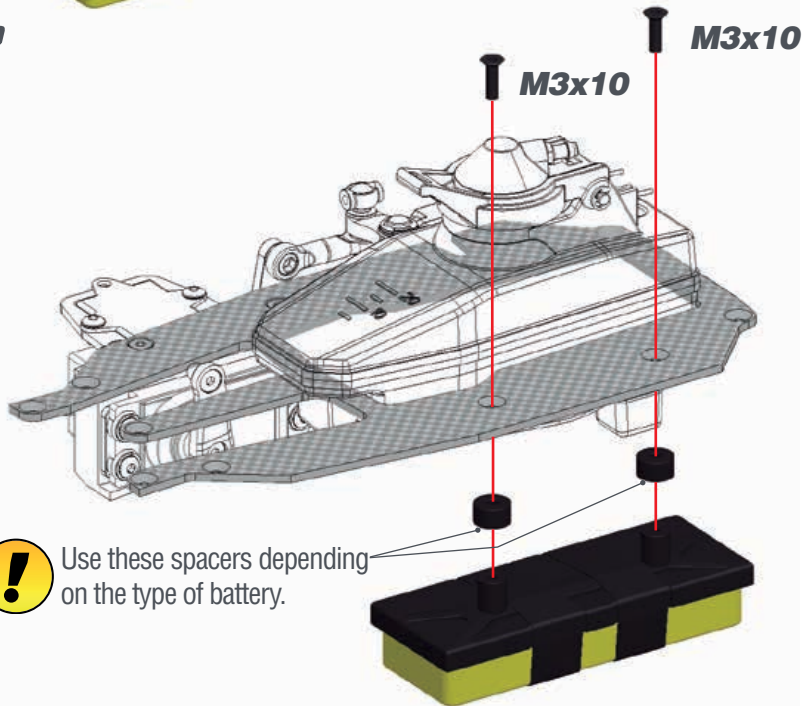

**!** Use these spacers depending on the type of battery.

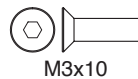

**STEP 39**

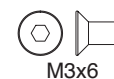
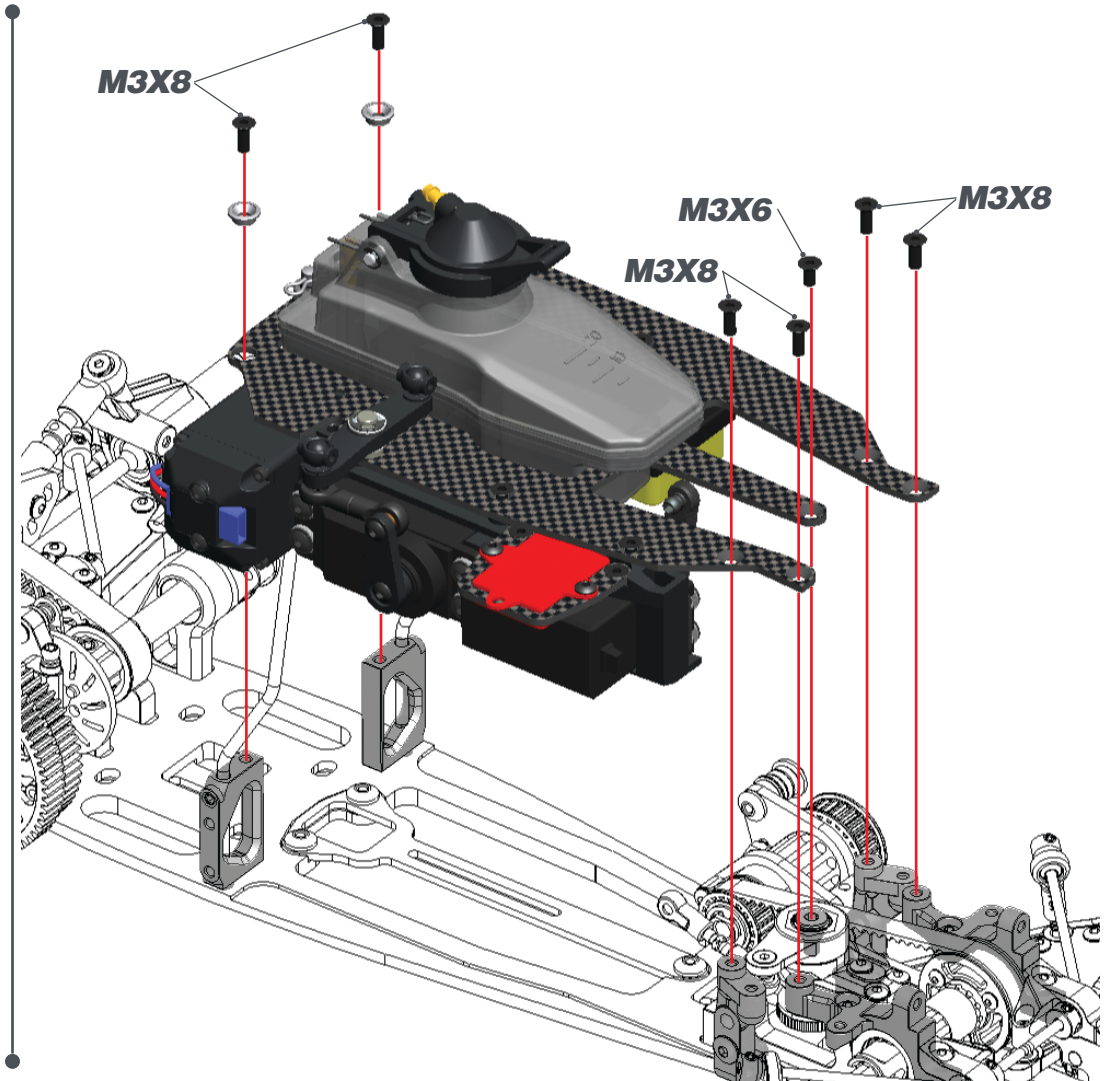



## STEP 40 BAG 11

## STEP 41

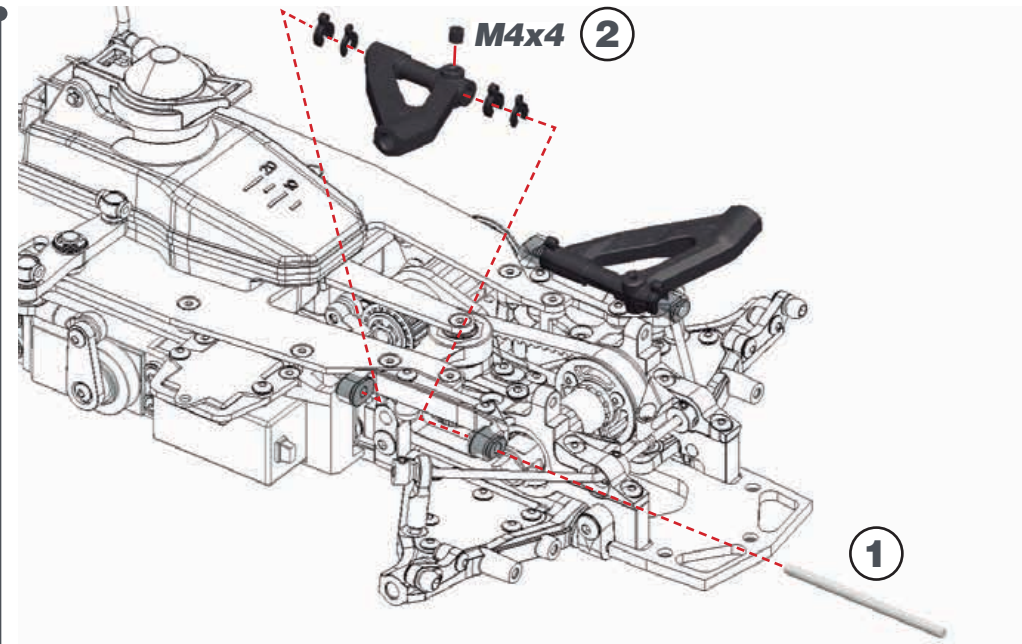
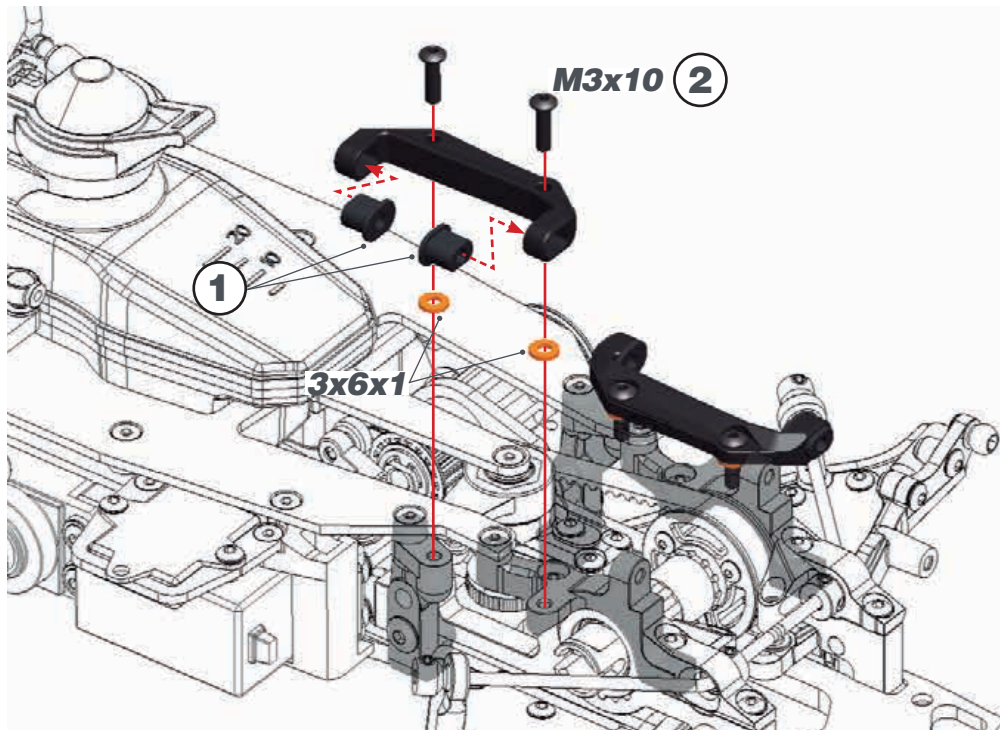

**L=R FRONT SUSPENSION INSERTS CHART**

INSIDE		MID		OUTSIDE	
RIGHT	LEFT	RIGHT	LEFT	RIGHT	LEFT

**L=R FRONT CASTER DEFAULT SPACERS**

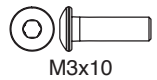

**STEP 42**

**42.1**

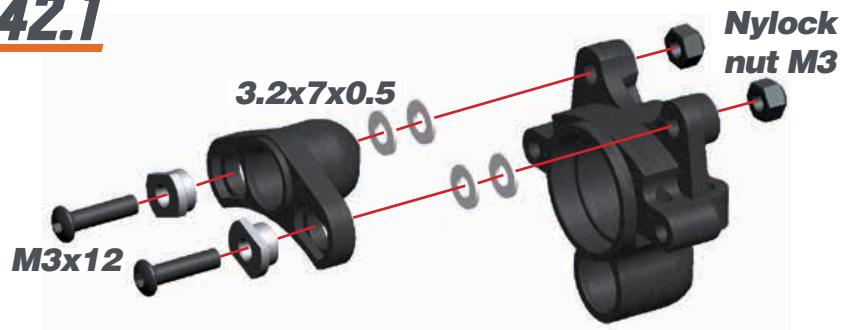

**42.2**

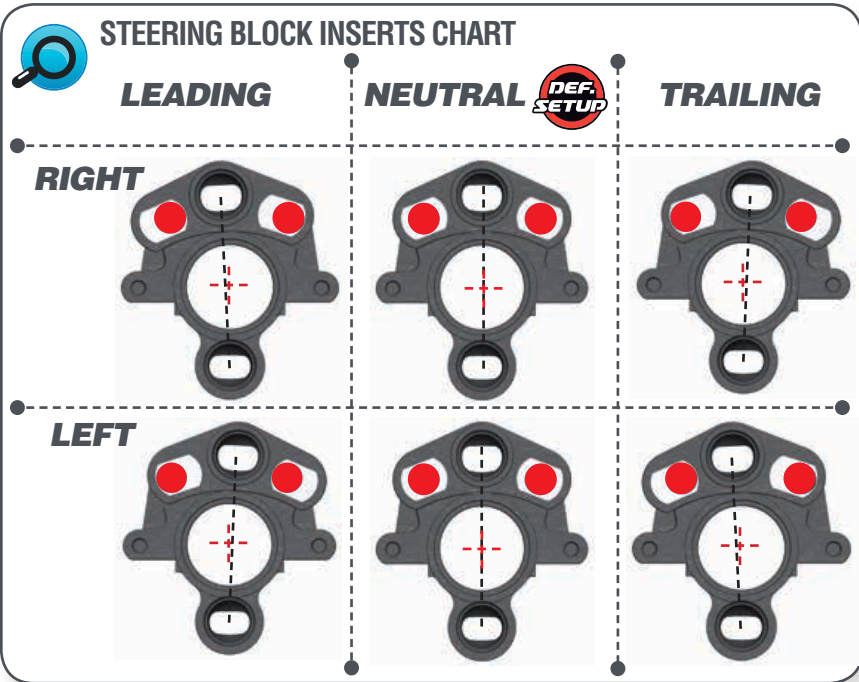
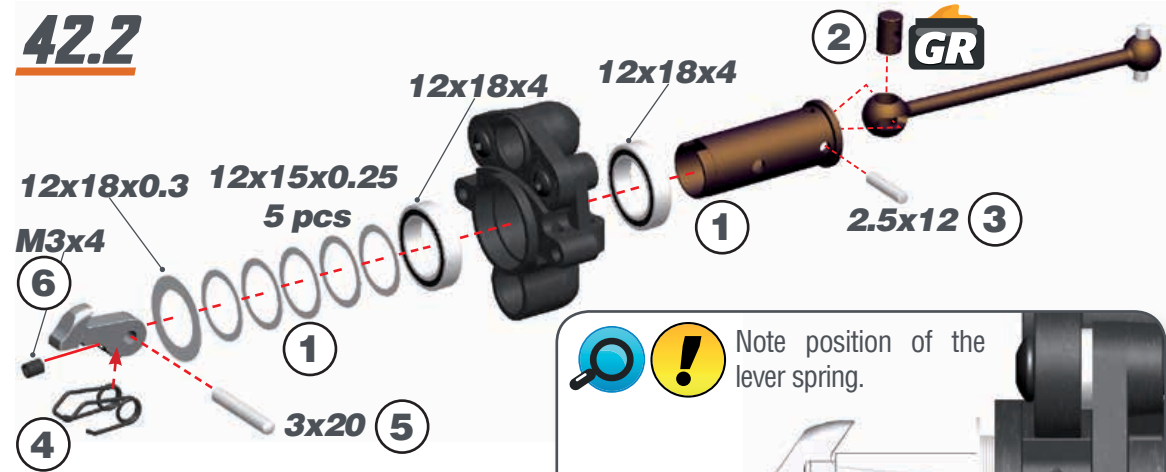

**42.3**

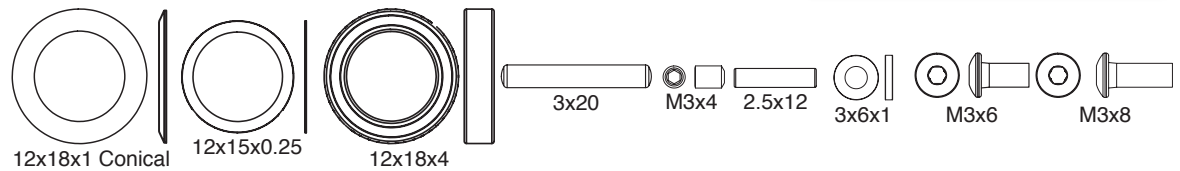



# STEP 43

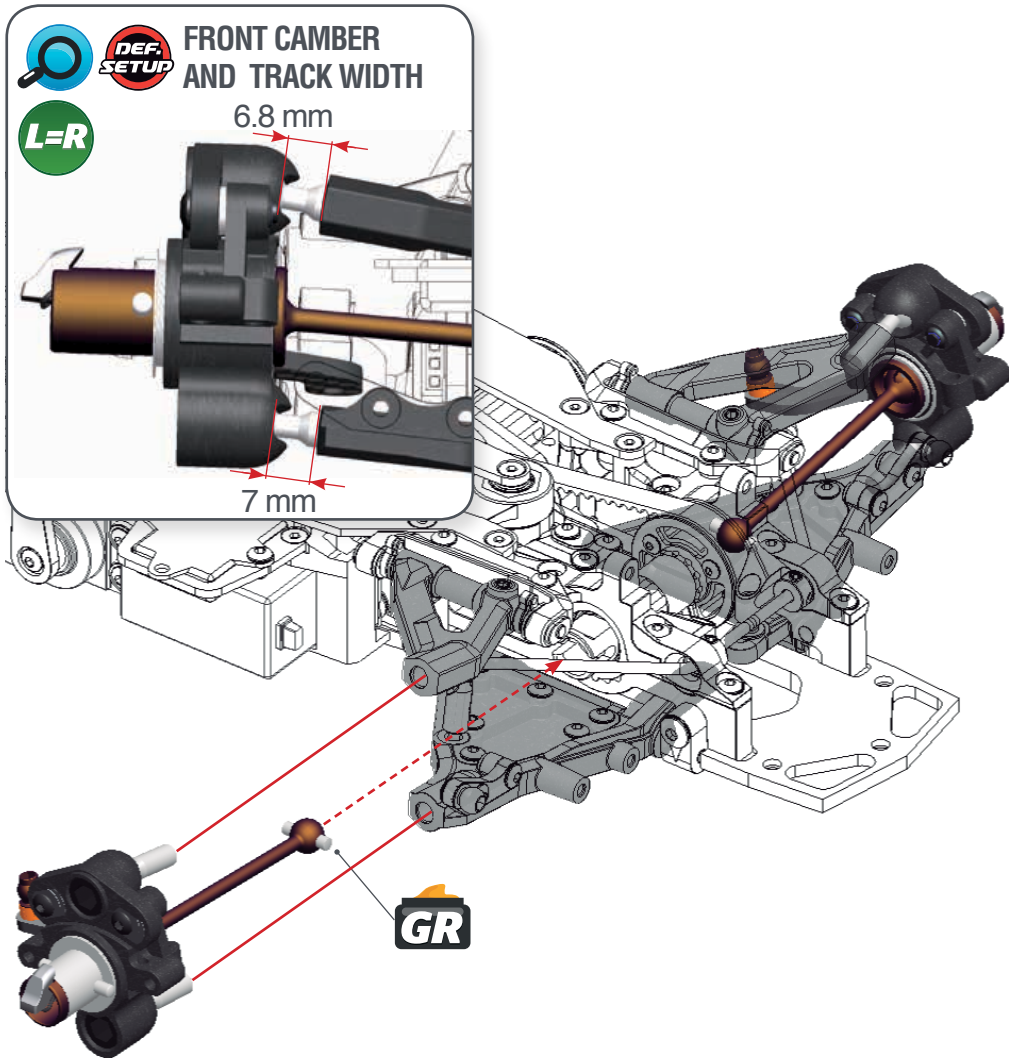

# STEP 44

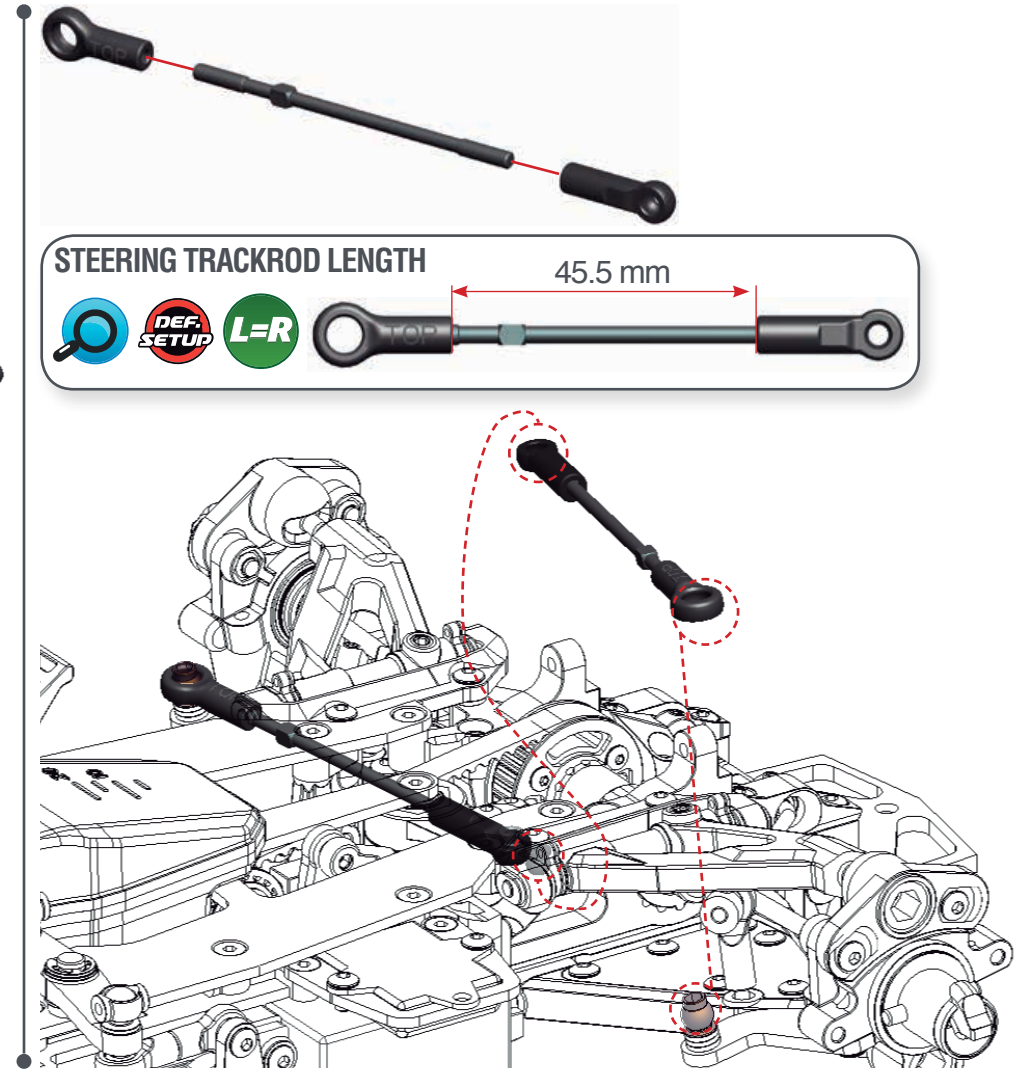



## STEP 45 SHOCKS BAG

### 45.1

Use some silicone oil during the assembly.

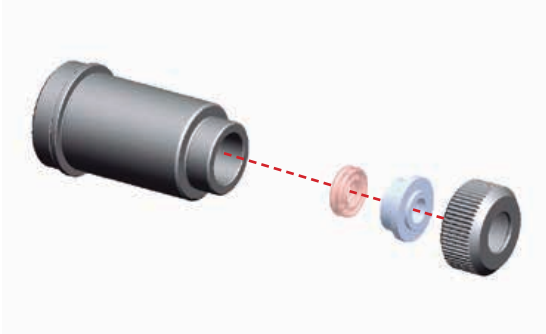

Note the correct orientation of the shock spacers .

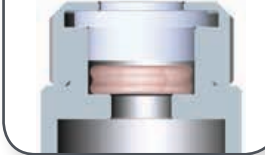

### 45.2

Insert the o-ring inside the spring collar.

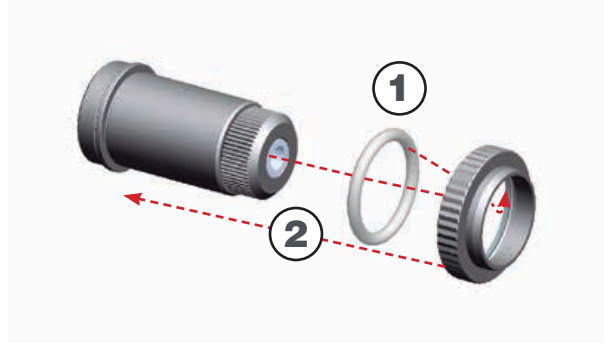

Note the correct position of the o-ring .



## STEP 46

### 46.1



For the correct piston holes please check the default setupsheet.

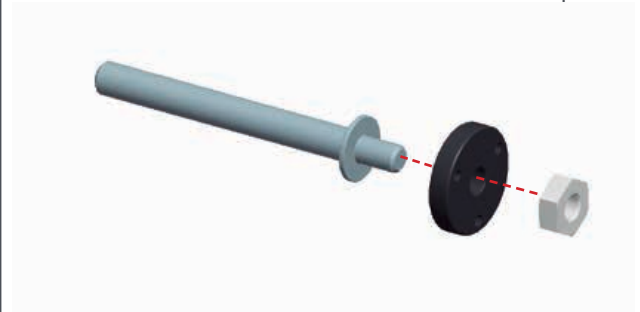

### 46.2



Use some silicone oil during the assembly.

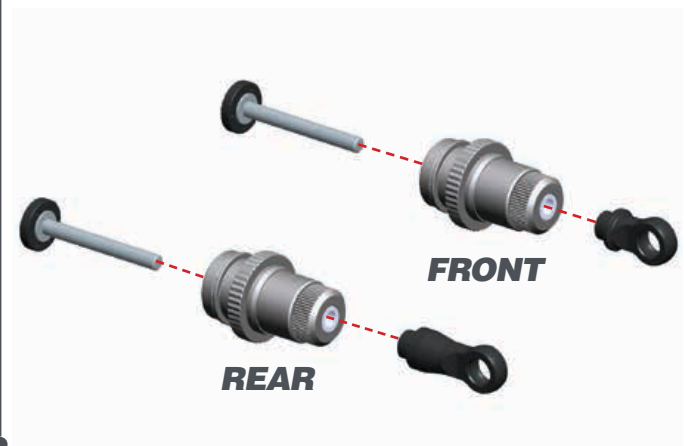

**STEP 47**

**47.1**

Push the shock top and the membrane into the shock cap.



**47.2**

1- Fill up with silicone oil fully using the silicone oil supplied in the kit. For the correct cst value please check the default setupsheet.

2- Extend the shockrod fully

3- Move the shockrod slowly up and down to let ALL air bubbles escape.

4- Close top only 3/4.



**47.3**

1-Bleed: push the shockrod all the way in slowly, to allow excessive oil to escape.

2- Close the shock cap completely.



**SHOCKS LENGTH:**

Measure the shock length fully extended.

**REAR**  
13 mm

**FRONT**  
14.5 mm

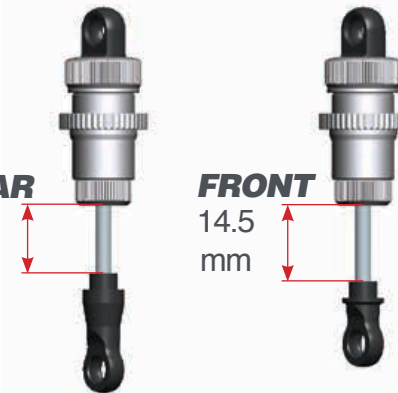

**STEP 48**

Assemble the spring and spring-cup (align correctly) to complete the shock.

**FRONT**



**REAR**



**STEP 50** **BAG 12**

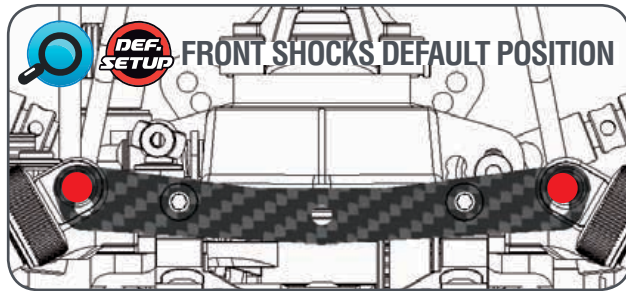
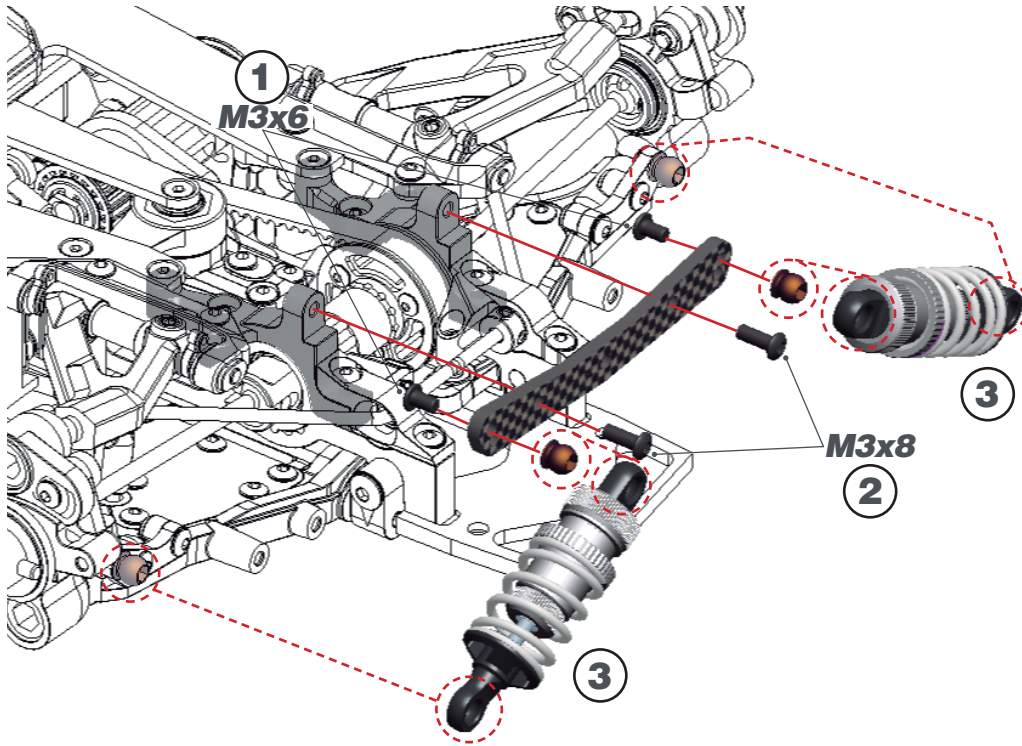

**STEP 51**

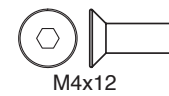
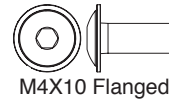
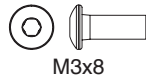
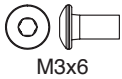
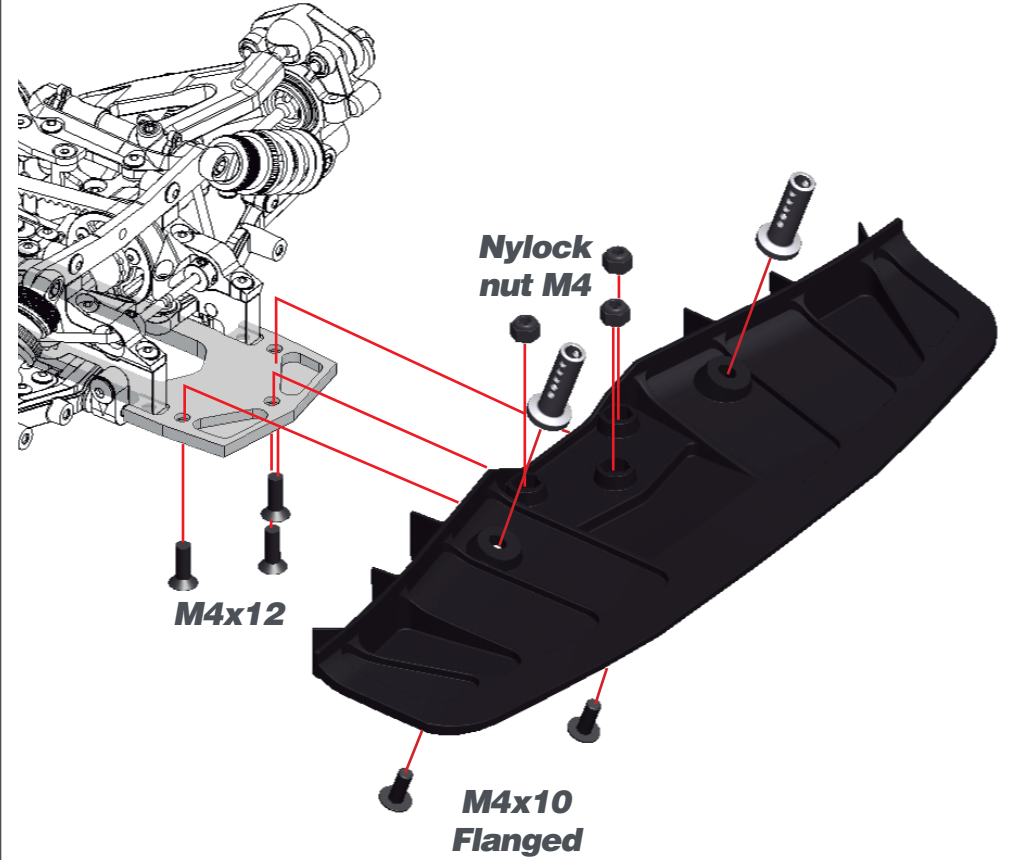



**STEP 52**

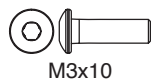
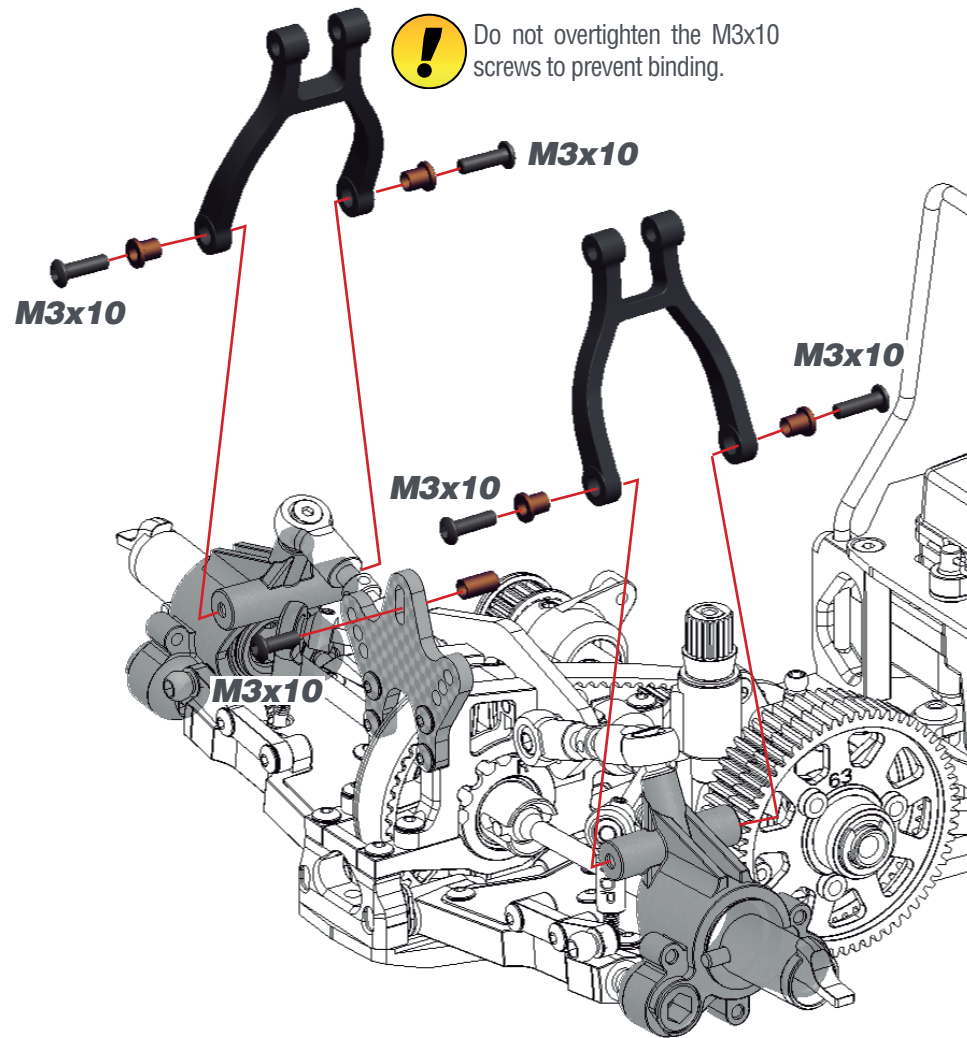

**STEP 53**

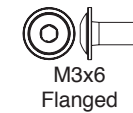
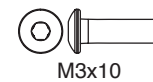

**STEP 54**

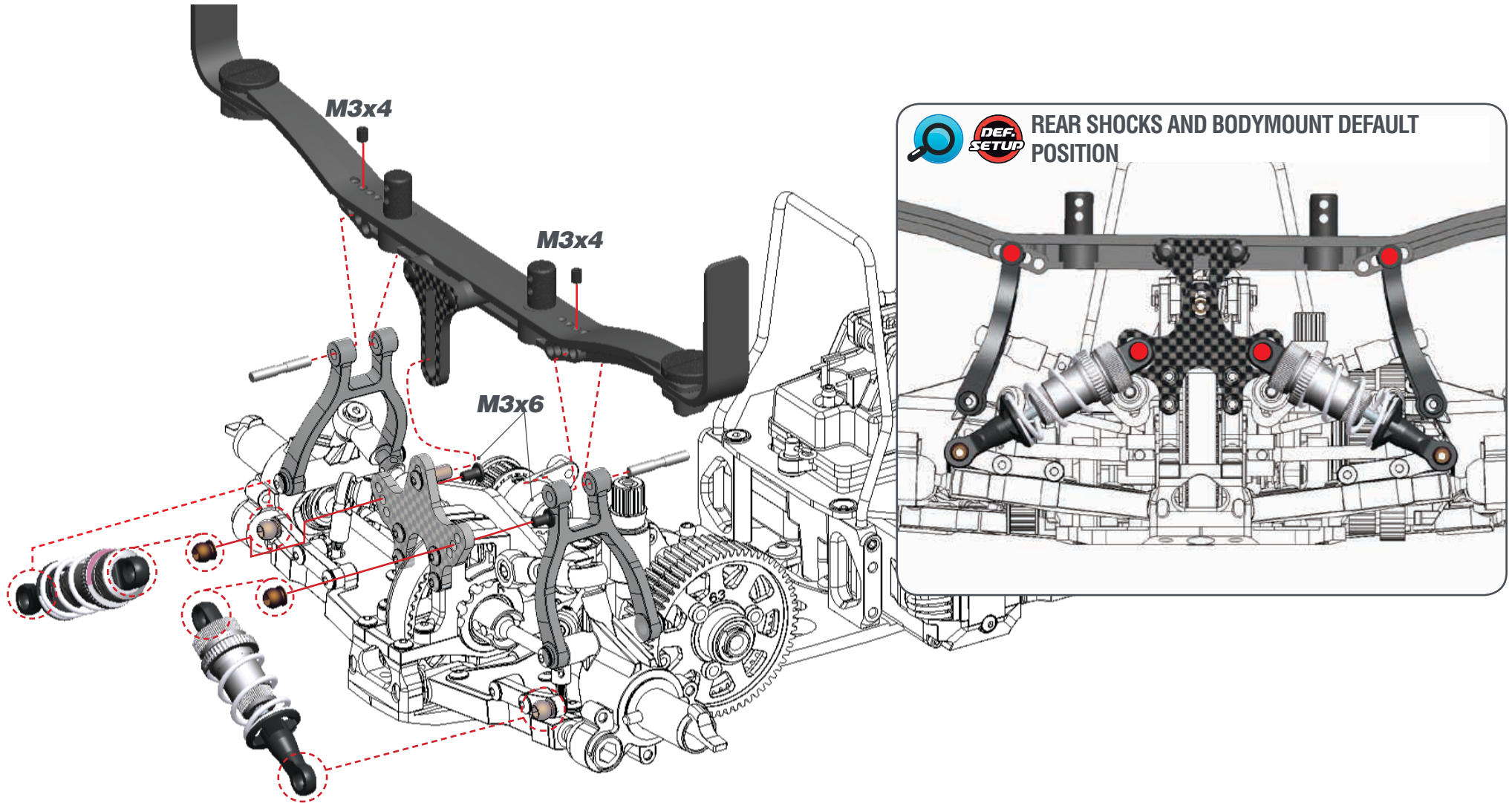

  
M3x4

  
M3x6

## STEP 55 CLUTCH BAG

### 55.1



1- To align the clutchgears with the 2-speed gears, it may be needed to use shim(s) 6x8x0.5mm (for 6mm shaft) or 7x8x0.5 (for 7mm shaft) behind the cone. This you can see only after assembling the clutch.

2- The holes in the side of the flywheel can be used to block the flywheel (with short allen tool) through the bottom of the chassis, when the engine/clutch is mounted in the car. It's easier to tighten or loosen the pre-load on the clutch spring that way.

### 55.2

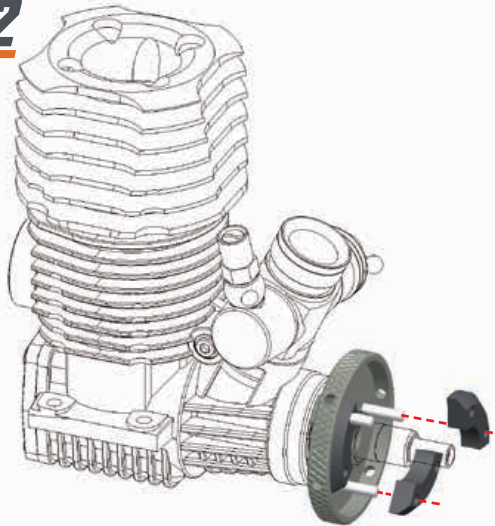

Note the orientation of the flyweights. Use the right hole for having a more aggressive clutch

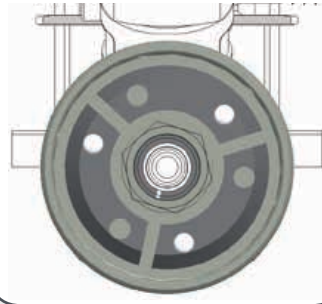

## STEP 56

### 56.1

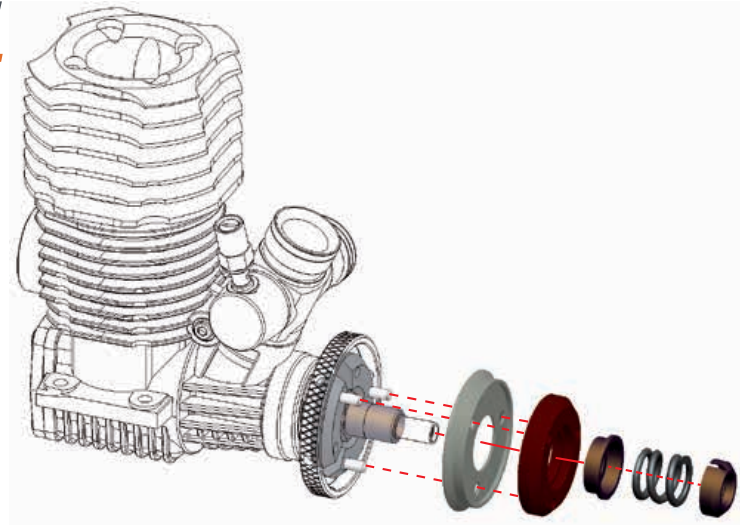

### 56.2



For adjusting the default clutch spring tension:

- 1- Screw in the adjusting nut all the way.
- 2- Unscrew it one and a half turns.
- 3- Fine tune the setup of your clutch on the track according to your driving style, track and weather conditions.

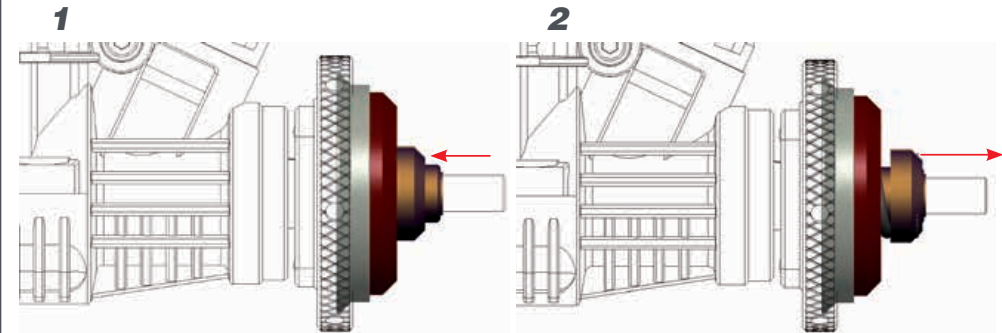



**STEP 57**

**57.1**

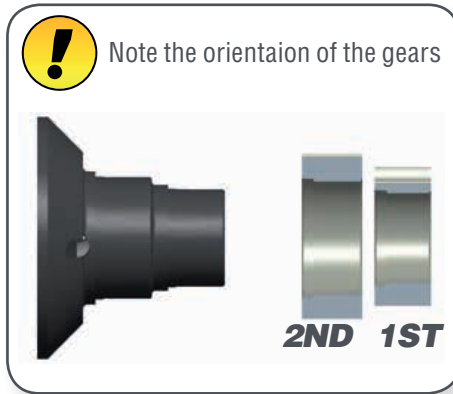
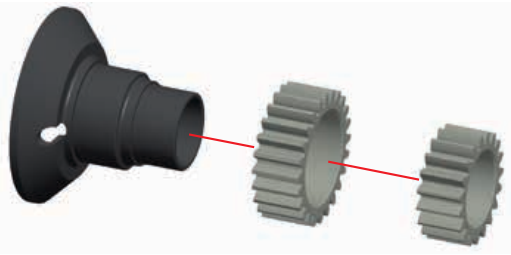

**57.2**

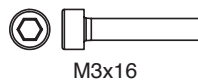
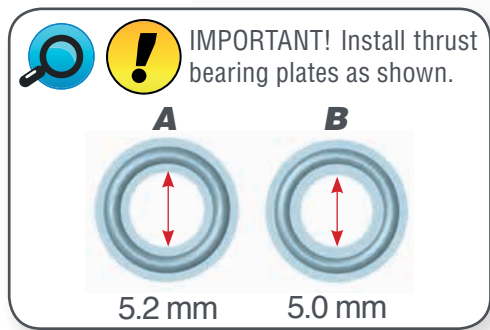
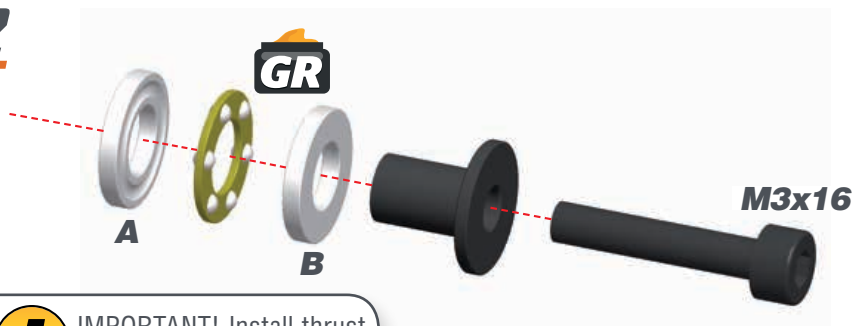

**STEP 58**

**58.1** - SETTING THE CLUTCH GAP

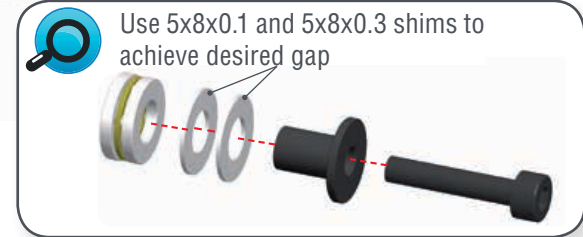
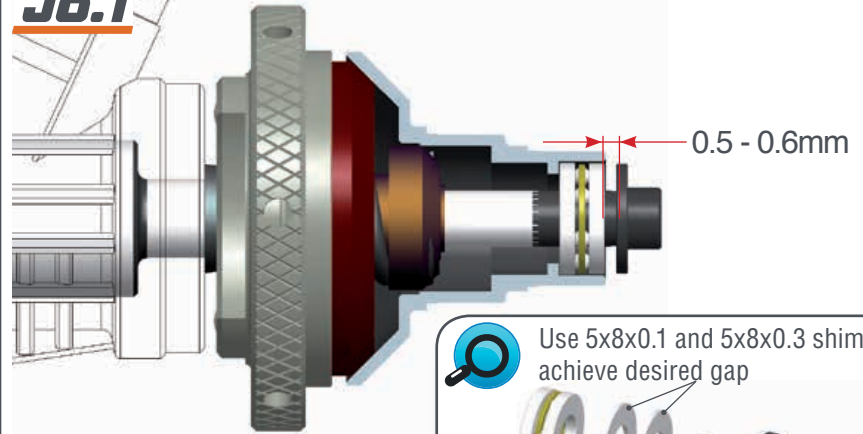

**58.2** SETTING THE CLUTCH END PLAY

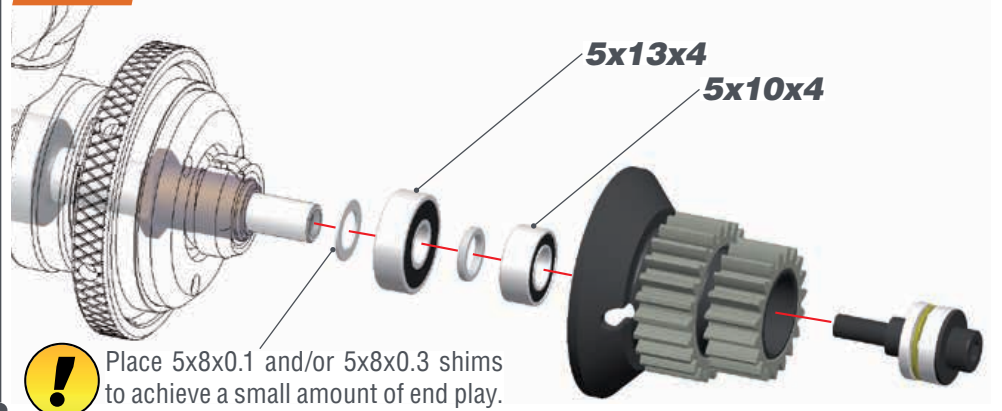

Place 5x8x0.1 and/or 5x8x0.3 shims to achieve a small amount of end play.

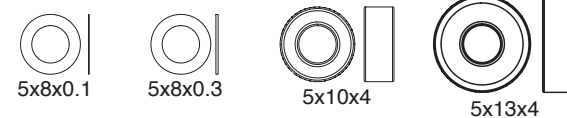

## STEP 59 BAG 13

### 59.1

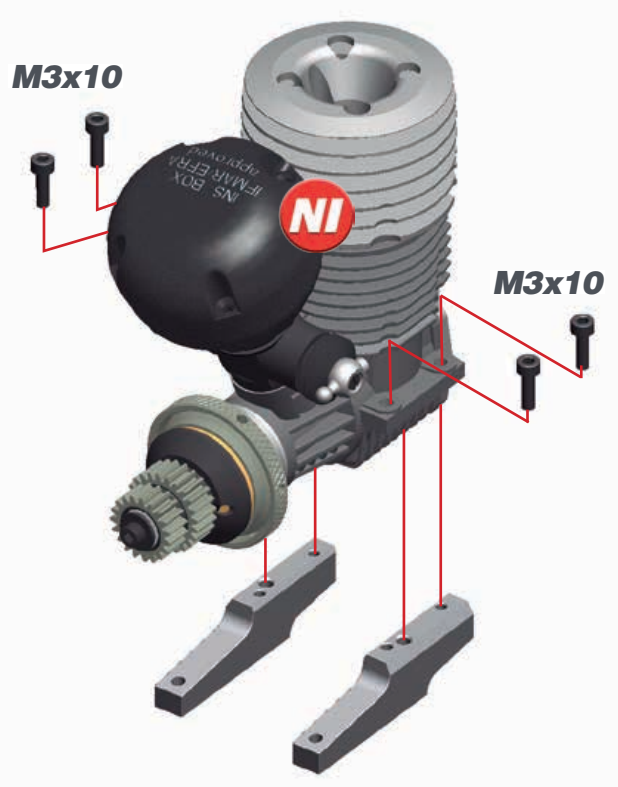

### 59.2

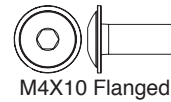
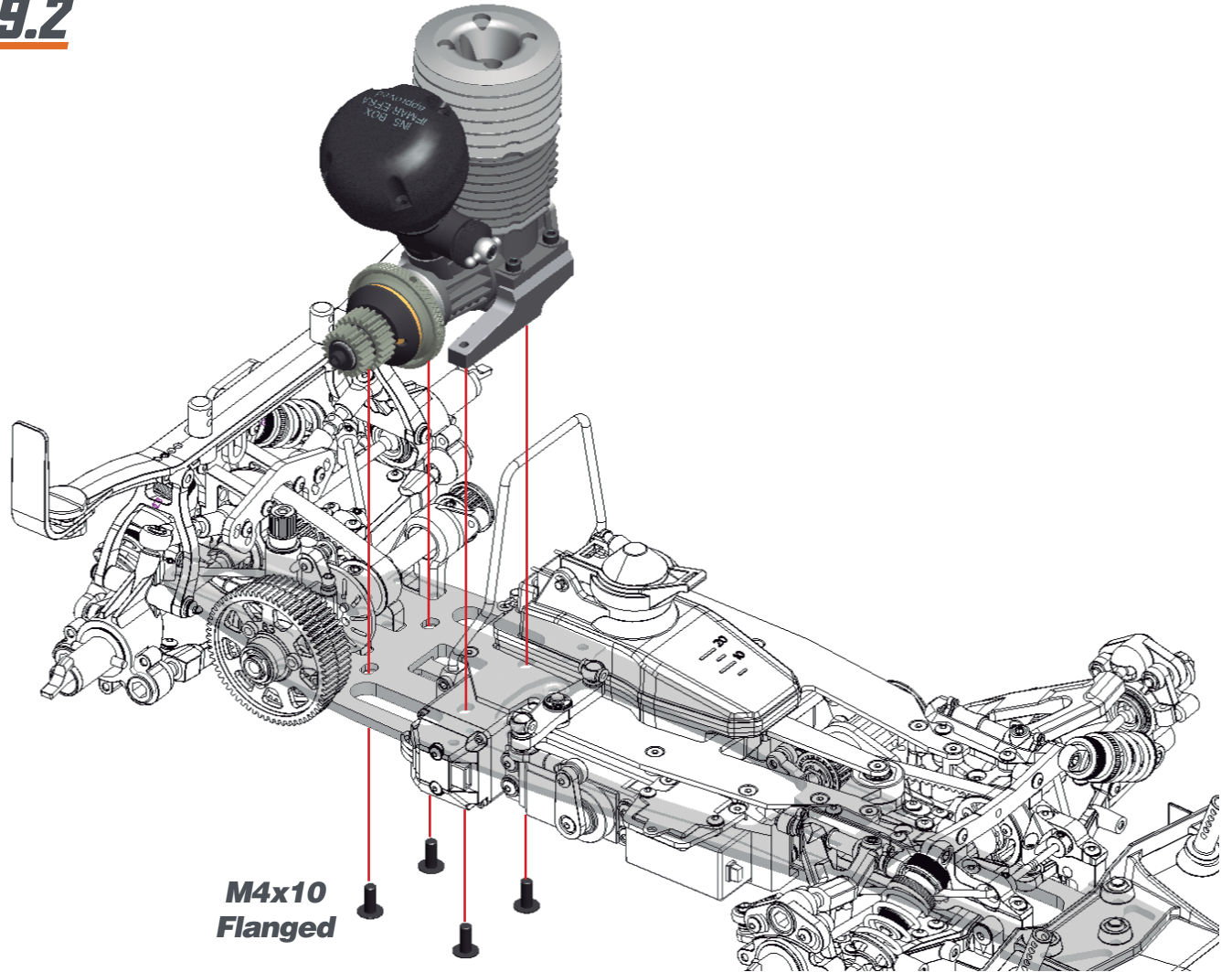

**STEP 60**

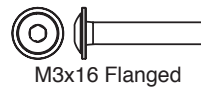
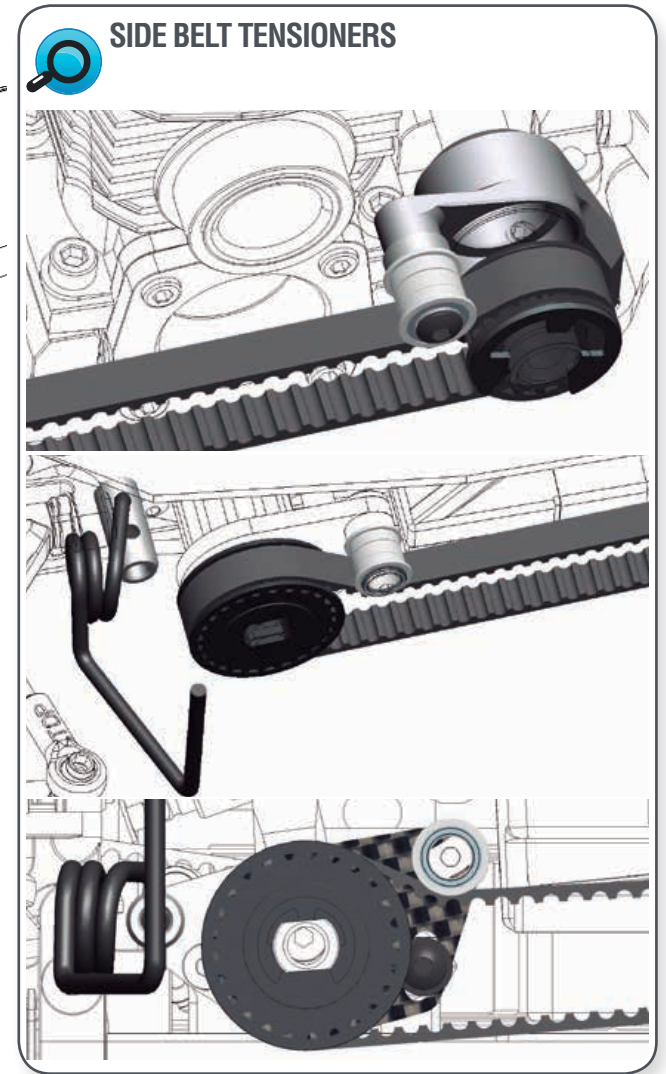
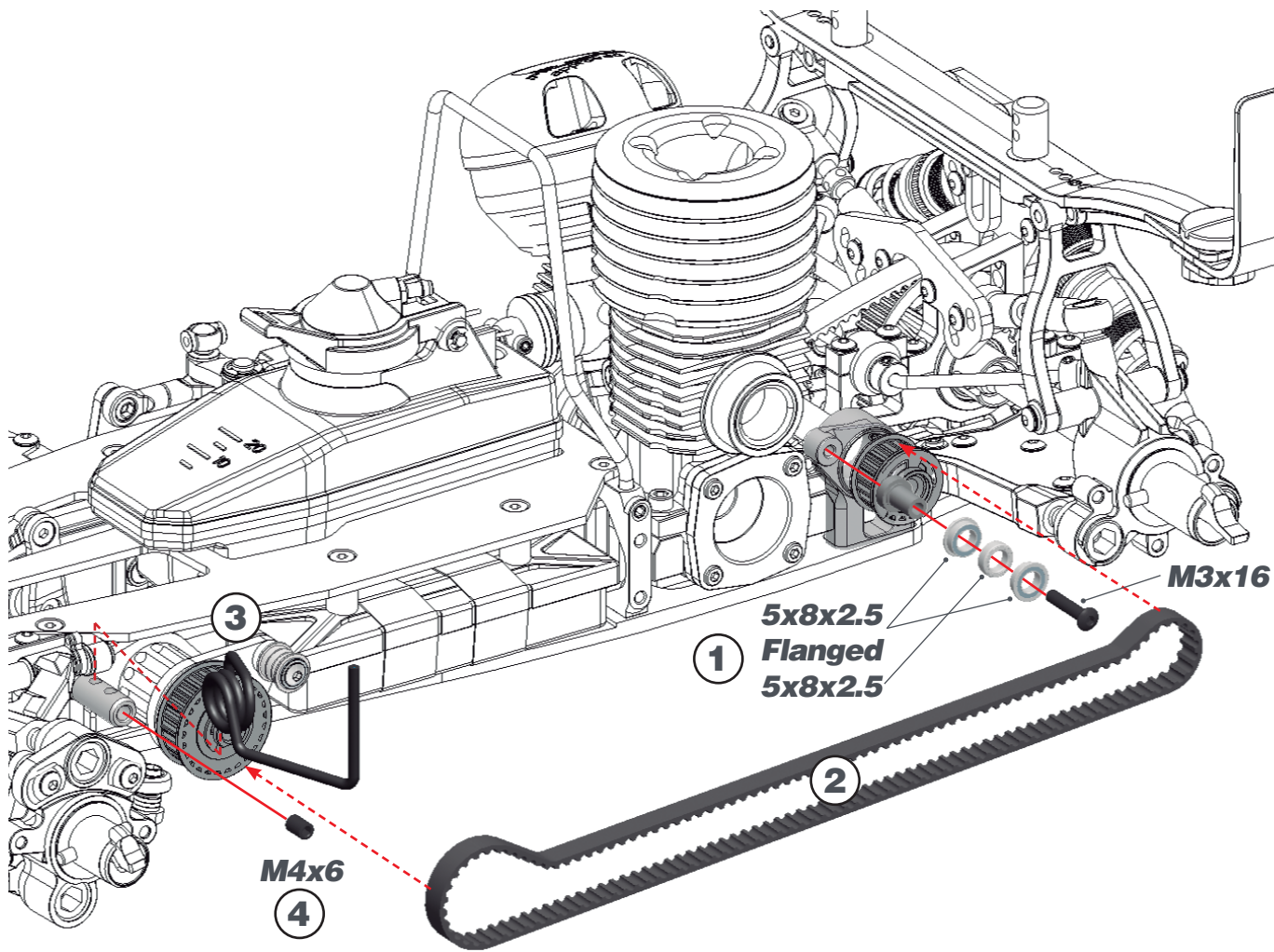



**STEP 61**

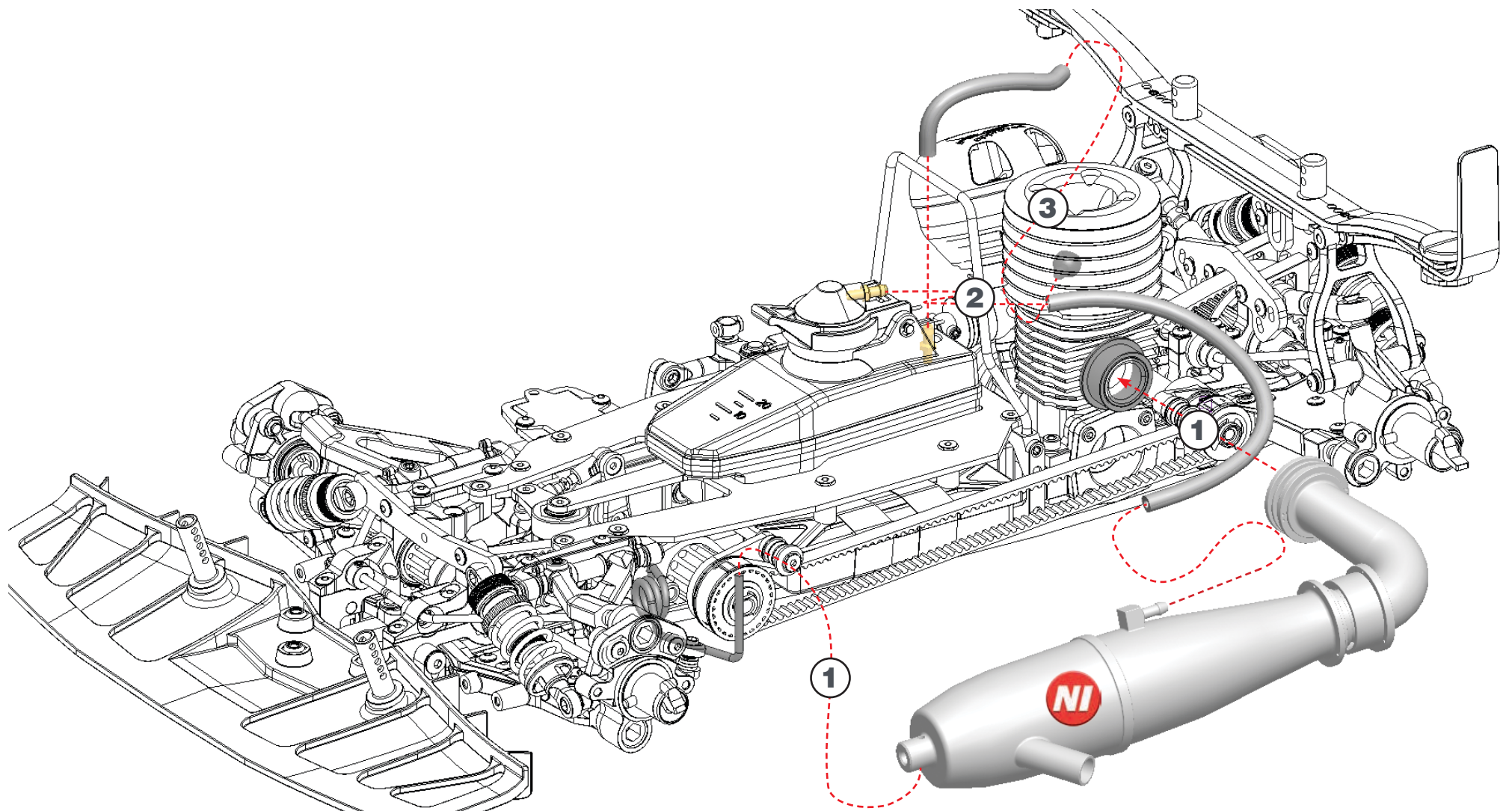

**STEP 62**

**62.1**



**62.2**

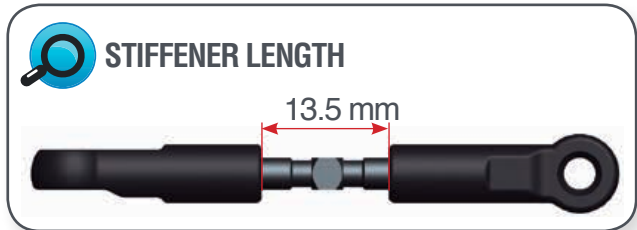

**62.3**

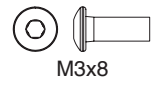
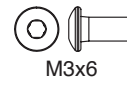
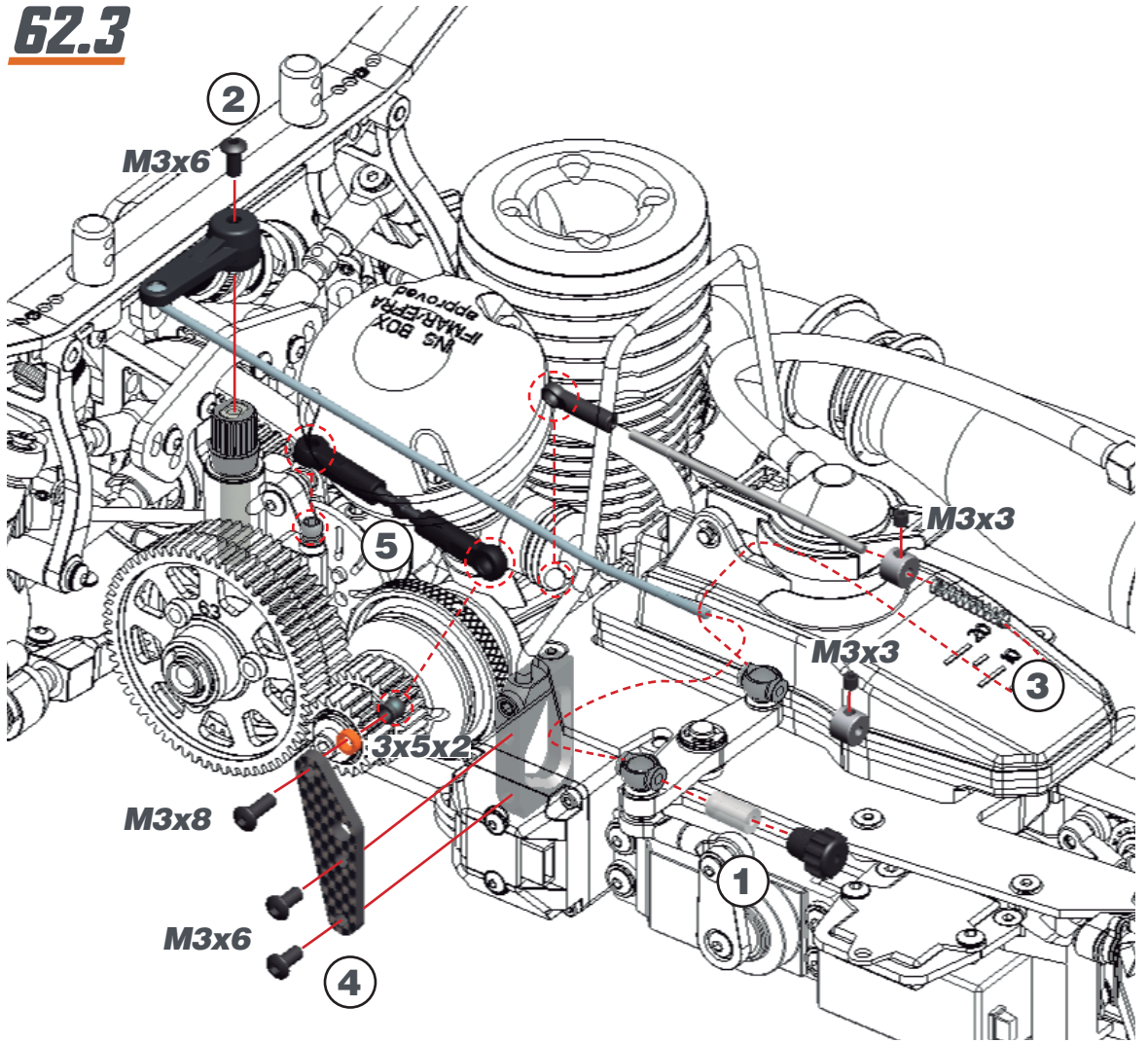

**STEP 63**

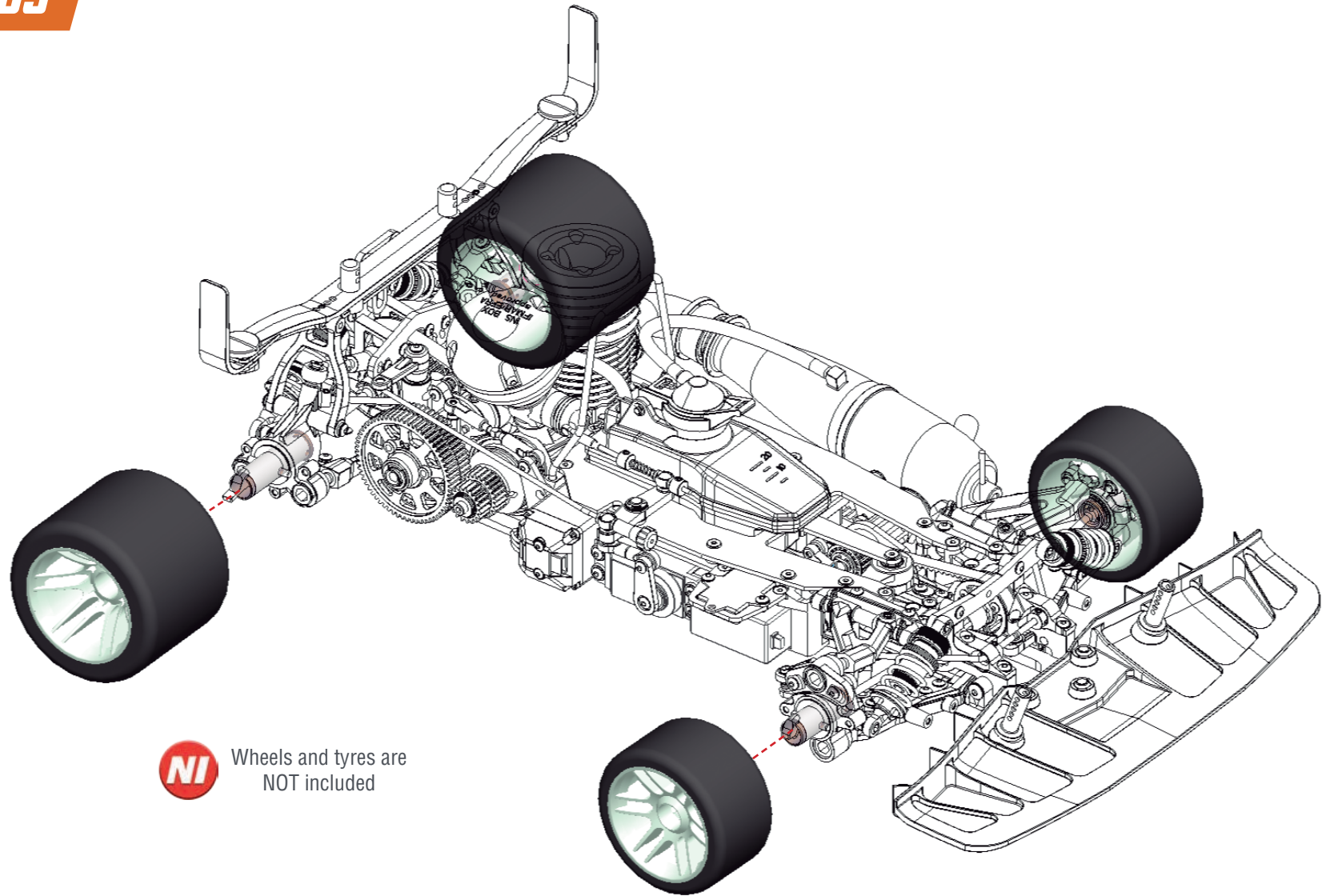

**NI** Wheels and tyres are NOT included



## INDEX

<b>CLUTCH AND GEARBOX EXPLODED VIEW</b>	<b>47</b>
<b>SHOCKS EXPLODED VIEW</b>	<b>48</b>
<b>REAR EXPLODED VIEW</b>	<b>49</b>
<b>FRONT I EXPLODED VIEW</b>	<b>50</b>
<b>RADIO EXPLODED VIEW</b>	<b>51</b>
<b>FRONT II EXPLODED VIEW</b>	<b>52</b>
<b>BUMPER AND BODYMOUNT EXPLODED VIEW</b>	<b>53</b>
<b>FINAL EXPLODED VIEW</b>	<b>54</b>
<b>TEAM SERPENT NETWORK</b>	<b>55</b>

# CLUTCH AND GEARBOX EXPLODED VIEW

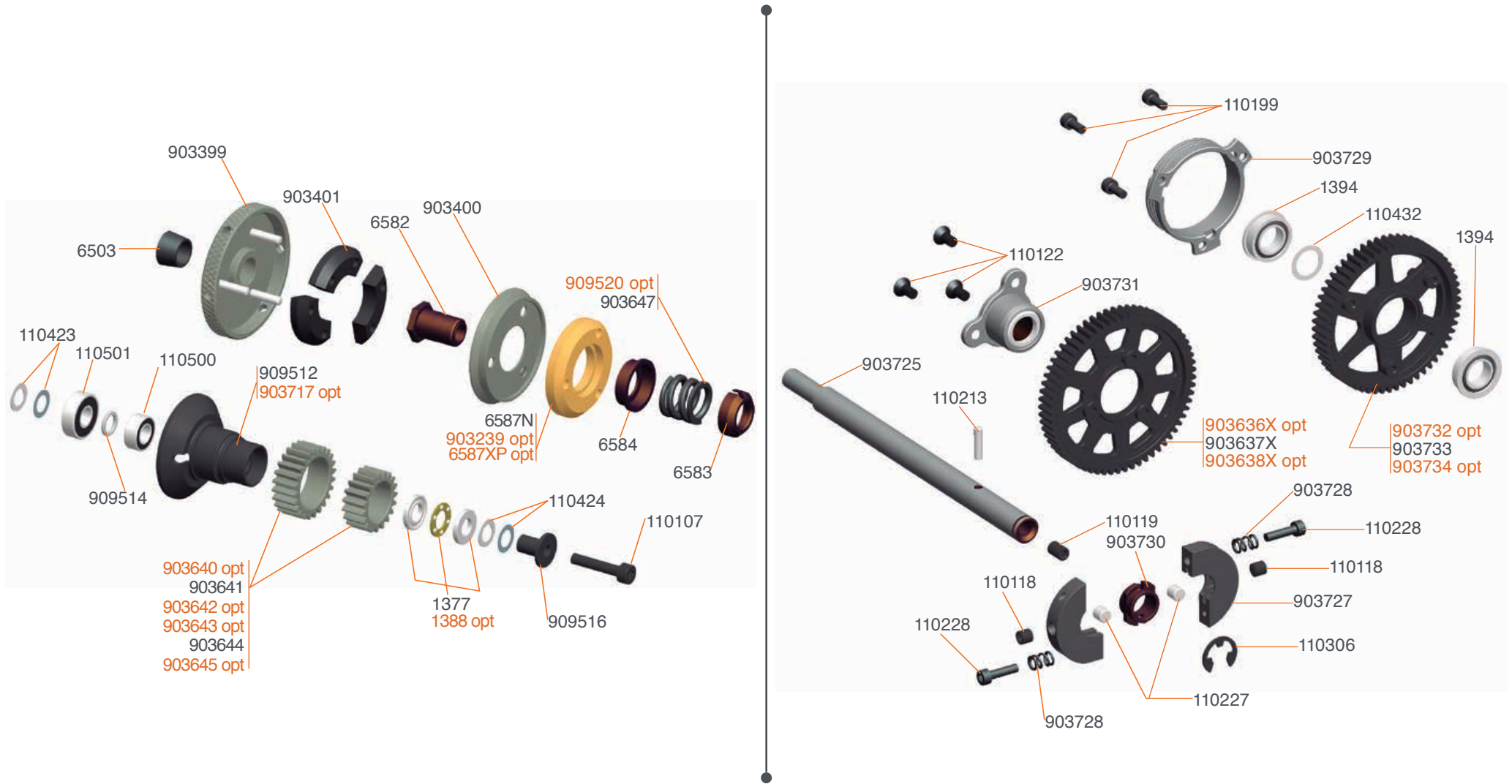

6587XP Centax clutch shoe XP  
 903239 Centax-2 clutch shoe red  
 903640 Centax gear-pinion alu 18T XLI  
 903642 Centax gear-pinion alu 20T XLI  
 903643 Centax gear-pinion alu 23T XLI

903645 Centax gear-pinion alu 25T XLI  
 903646 Centax gear-pinion alu set XLI (6)  
 903636X 2-speed gear 61T SL8 XLI V2  
 903638X 2-speed gear 63T SL8 XLI V2  
 903717 Centax clutchbell alu nickel coated V2

903732 2-speed gear 56T XLI Gen2  
 903734 2-speed gear 58T XLI Gen2  
 903771 2-speed gear set (6) XLI Gen2  
 909520 Centax II / III spring 1.8 (10mm)



903741 Shockset XLV short (2)

- 160320 opt
- 160321 opt
- 160322 opt
- 160323 opt
- 160324
- 160325 opt
- 160326 opt
- 160327 opt
- 160328 opt
- 160329 opt
- 160330 opt

- 160300 opt
- 160301 opt
- 160302 opt
- 160303 opt
- 160304 opt
- 160305 opt
- 160306
- 160307 opt
- 160308 opt
- 160309 opt
- 160310 opt

- 160134
- 903777 opt
- 903778 opt
- 903779 opt

- 160147 Shock onroad big bore bushing LF (4)
- 160300 Spring white L23 (2.3/13) (2)
- 160301 Spring yellow L23 (2.8/16) (2)
- 160302 Spring orange L23 (3.4/19.5) (2)
- 160303 Spring red L23 (4.1/23.5) (2)
- 160304 Spring pink L23 (4.0/28) (2)
- 160305 Spring blue L23 (5.8/33) (2)
- 160307 Spring green L23 (8/45.5) (2)
- 160308 Spring grey L23 (9/51.5) (2)
- 160309 Spring black L23 (10/57) (2)

- 160310 Spring-set short (5x2)
- 160320 Spring white L27 (2.3/13) (2)
- 160321 Spring yellow L27 (2.8/16) (2)
- 160322 Spring orange L27 (3.4/19.5) (2)
- 160323 Spring red L27 (4.1/23.5) (2)
- 160325 Spring blue L27 (5.8/33) (2)
- 160326 Spring purple L27 (6.8/39) (2)
- 160327 Spring green L27 (8/45.5) (2)
- 160328 Spring grey L27 (9/51.5) (2)
- 160329 Spring black L27 (10/57) (2)

- 160330 Spring-set L27 (5x2)
- 903777 Shock piston XLV 1 hole (4)
- 903778 Shock piston XLV 2 hole (4)
- 903779 Shock piston XLV 3 hole (4)





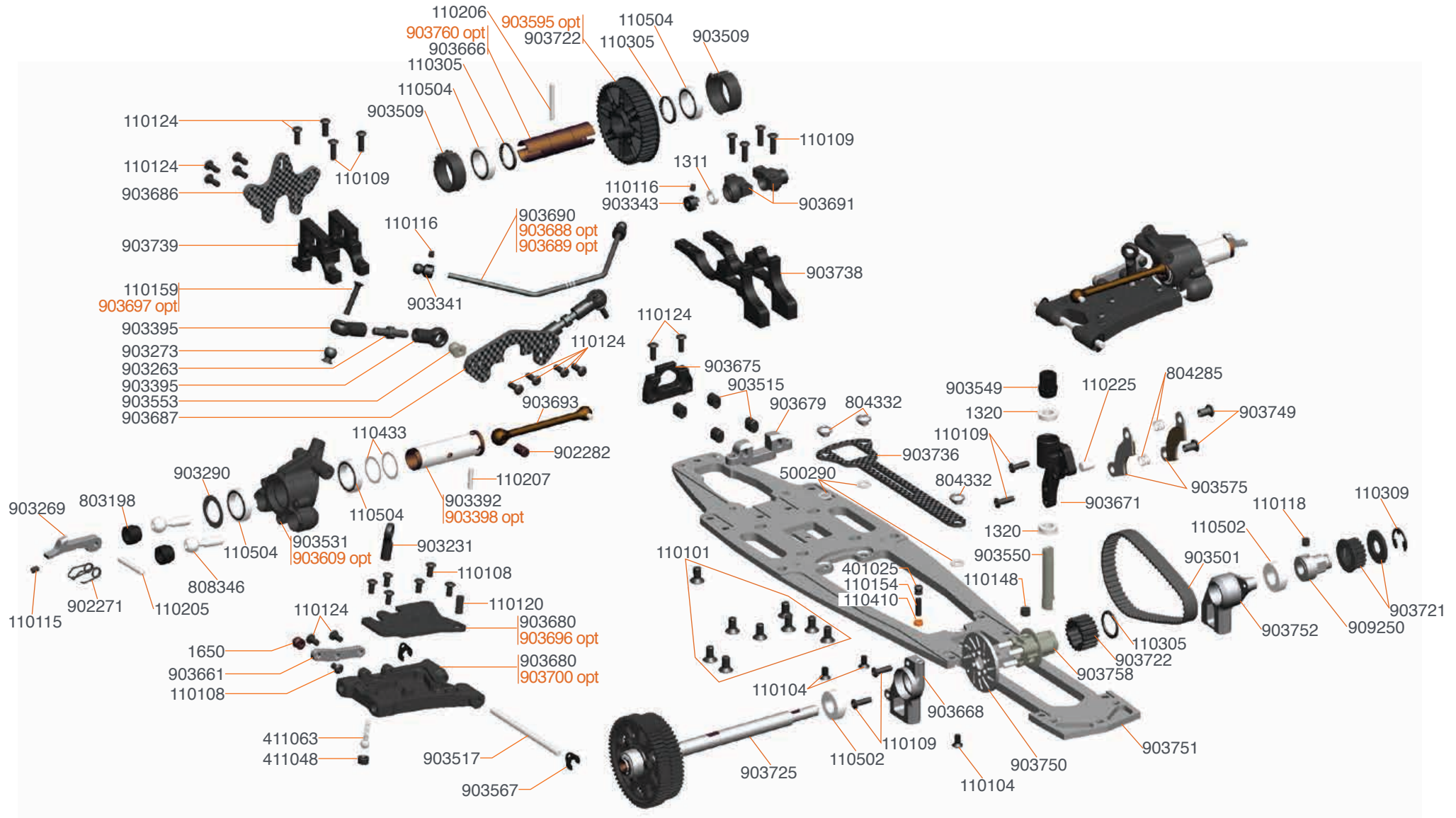

- 903398 Rear wheelaxle cvd alu (2)
- 903595 Pulley rear axle 48T alu
- 903609 Upright (2) hard
- 903688 Antirroll bar FR/RR soft S988
- 903689 Antirroll bar FR/RR medium S988

- 903697 Camberlink riser 1/8 (2)
- 903696 Wishbone insert carbon RR lw (2)
- 903700 Wishbone RR lw L+R hard S988
- 903759 Chassis weight 14gr brass S989
- 903760 Solidaxle light S989





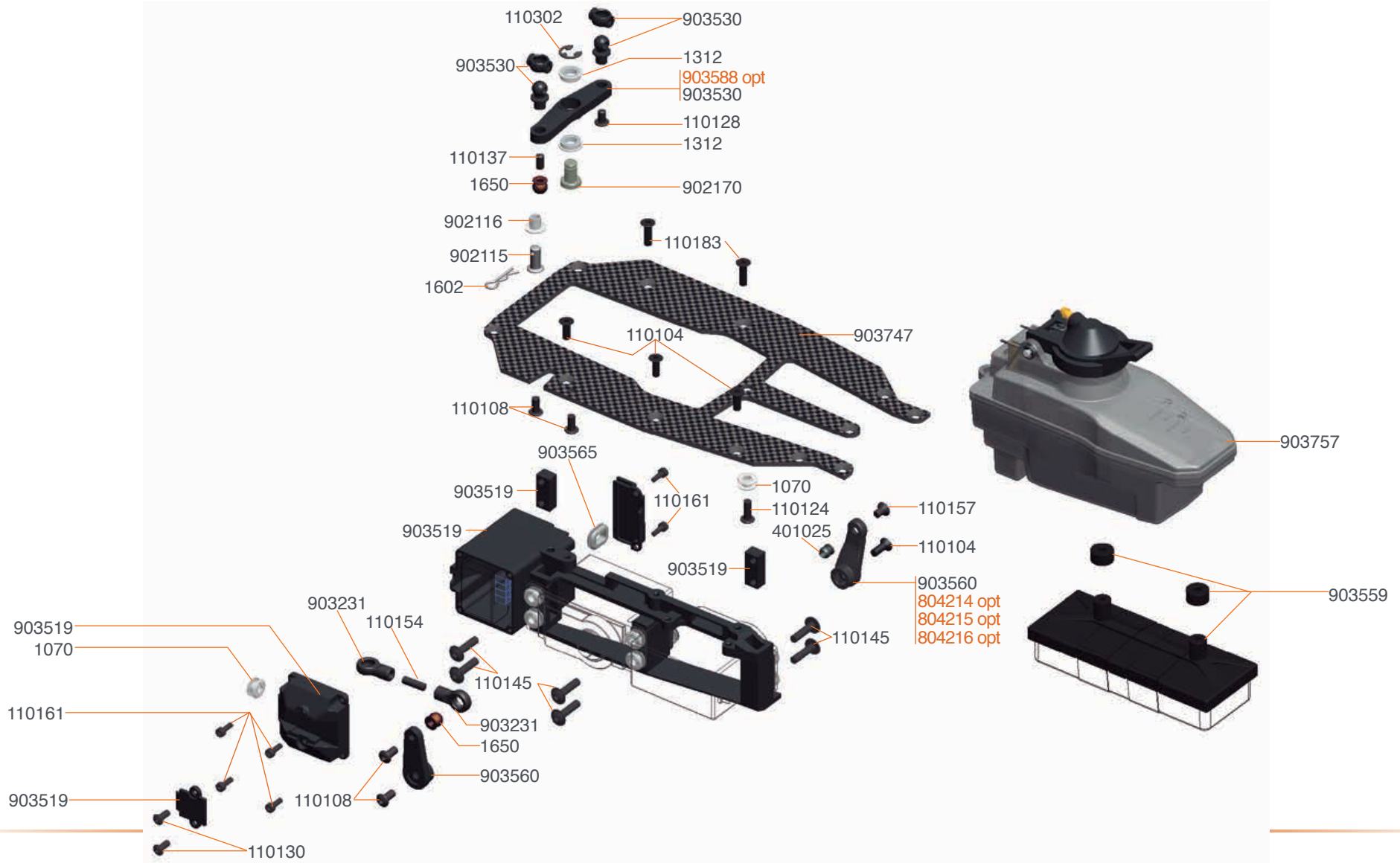

**OPT** 804214 Steering lever 23T alu  
 804215 Steering lever 24T alu  
 804216 Steering lever 25T alu

903588 Throttle lever alu



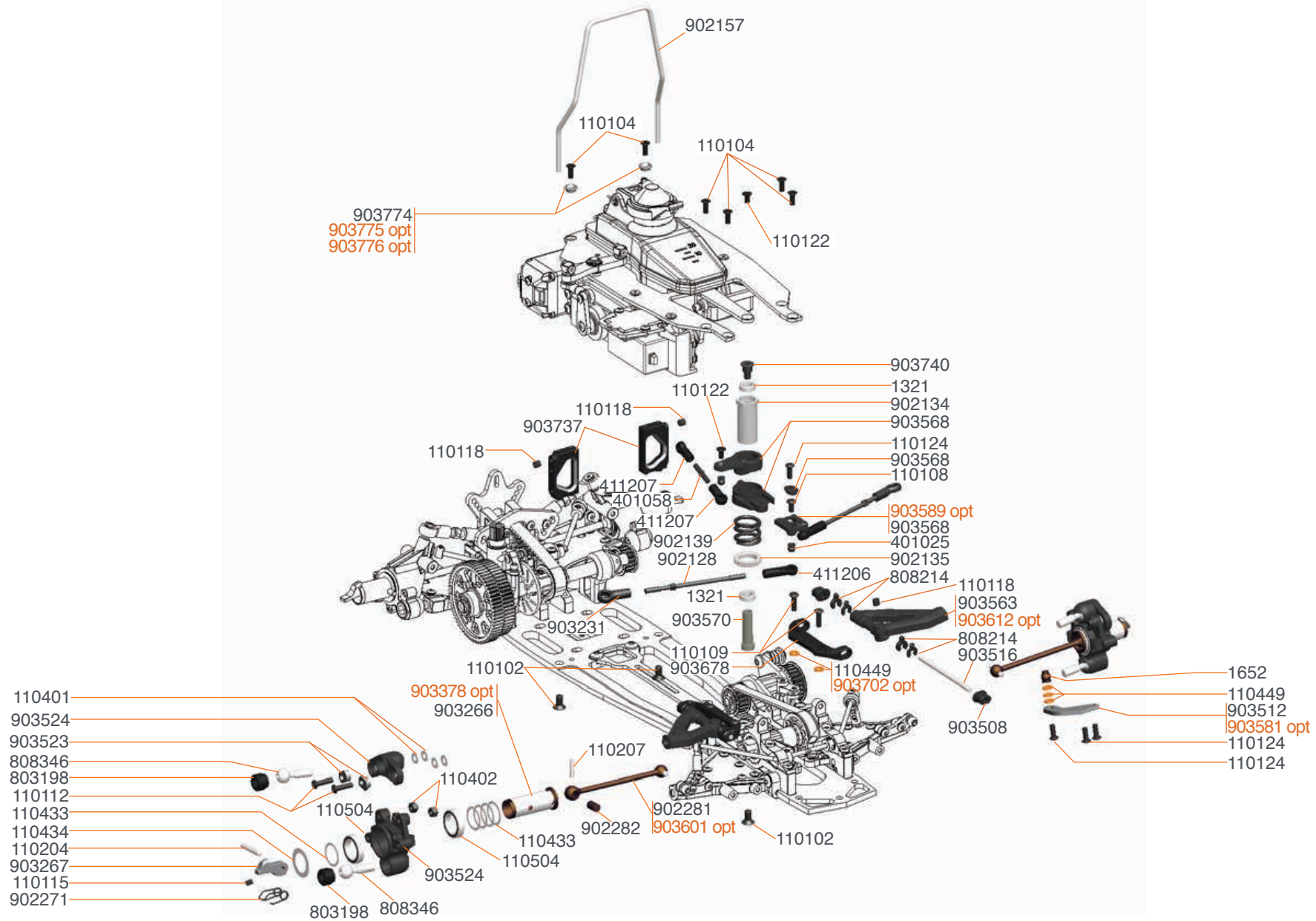

903378 Wheelaxle front OS2 Alu (2)  
903581 Steeringblock lever carbon (2)  
903589 Servosaver bottom alu (2)

903601 Driveshaft cvd FR alu (2)  
903612 Wishbone FR up (2) hard  
903702 Rollcenter spacer fr (2) S988

903775 Flex set S989  
903776 Flex insert (2) S989



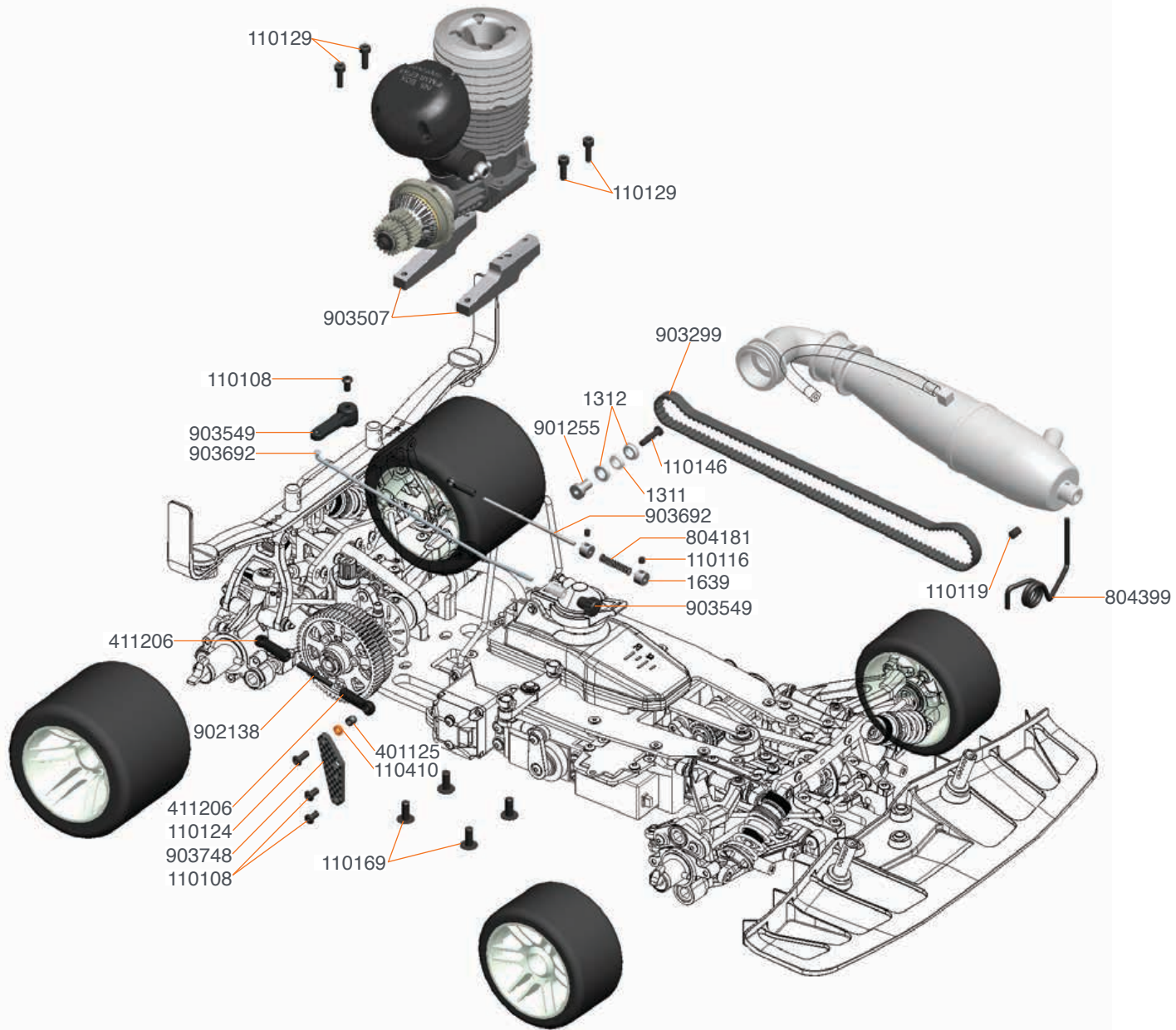



**NOTES:**

A series of ten horizontal dashed orange lines providing space for handwritten notes.

# TEAM SERPENT NETWORK

**989 SPARE PARTS** [www.serpent.com/903018/spares/](http://www.serpent.com/903018/spares/)



**989 OPTIONALS PARTS** [www.serpent.com/903018/Optionals/](http://www.serpent.com/903018/Optionals/)



**SERPENT TOOLS** [www.serpent.com/product/Tools/](http://www.serpent.com/product/Tools/)



**SERPENT MERCHANDISING** [www.serpent.com/product/Merchandising/](http://www.serpent.com/product/Merchandising/)



## SERPENT WEBSITE AND BLOG

[www.serpent.com](http://www.serpent.com)

[www.teamserpent.com](http://www.teamserpent.com)

[www.dragon-rc.com](http://www.dragon-rc.com)

**SERPENT PROMO PAGES** <http://promo.serpent.com>

**SERPENT FACEBOOK GROUPS** <http://promo.serpent.com/indexfb.htm>

**SERPENT ADVANCED MANUALS** <http://promo.serpent.com/sam/>

## SERPENT SOCIAL MEDIA



[www.facebook.com/SerpentMRC](http://www.facebook.com/SerpentMRC)



[www.youtube.com/user/SerpentMRC](http://www.youtube.com/user/SerpentMRC)



[www.twitter.com/SerpentMRC](http://www.twitter.com/SerpentMRC)



[www.plus.google.com/+SerpentModelcars/posts](http://www.plus.google.com/+SerpentModelcars/posts)



[www.weibo.com/teamserpent](http://www.weibo.com/teamserpent)



# VIPER 989

## Instruction Manual



Manual 989 #57488-1

# SERPENT