

NATRIX 748 WC

**INSTRUCTION
MANUAL**



GP
1/10 scale 4wd

INTRODUCTION

Thank you very much for selecting this Serpent rc car and thus become a member of the ever growing worldwide Serpent racing family. Serpent started in 1980 and has been growing its product-line and fan-base ever since.

The Serpent Matrix 748-EVO is a state of the art gaspowered 1/10 scale onroad racing car. This evolution of the Worlds TQ car is taking performance to an even higher level. The assembly manual will guide you through all the steps to complete the car, so you can hit the track with a good base-set-up soonest. The Serpent design department succeeded to create a superbly performing car combined with eas of assembly and maintenance. The high quality standards of all parts and hardware will make racing your Serpent car a very rewarding activity !

Through our team, website and social media we will keep you up-to-date on all developments of the Serpent cars. We hope to meet you on the track and through our various media! Enjoy the drive !

Team Serpent
Multiple World Champions

INSTRUCTIONS

Serpent's long tradition of excellence extends to the instruction manuals, and this instruction manual is no exception. The easy-to-follow layout is richly illustrated with 3D-rendered full-color images to make your building experience quick and easy. Following the instructions will result in a well-built, high-performance race-car that will soon be able to unleash its full potential at the racetrack. The kit includes bags, with bagnumbers, which refer to the same step in the manual. Open only the indicated bag(s) per step and finish that part of the assembly. Remaining parts will be needed lateron in the assembly process.

PLASTIC PARTS

The Serpent moulded parts are very durable and hard. When assembling longer screws in new composite parts, make sure to use new hex bits in your (power) tools. Pre-threading also helps to avoid screw damage.

SETUP

In certain assembly steps you need to make basic adjustments, which will give you a good initial setup for your Serpent Matrix 748-EVO. Fine-tuning the initial setup is an essential part of building a high-performance racecar like your Serpent Matrix 748-EVO.

EXPLODED VIEWS AND PARTS LIST

The exploded views and parts lists for the Serpent Matrix 748-EVO are presented in the Reference Guide section in the back of this manual. The exploded views show all the parts of a particular assembly step along with the Serpent part number and hotlink to the Serpent website. Partnumbers in orange indicates that this part is an optional. Optionals part names and numbers are showed below.

CUSTOMER SERVICE

Serpent has made a strong effort to make this manual as complete and clear as possible. Additional info may be published in our website: www.serpent.com or you may ask your dealer or the Serpent distributor for advice, or email Serpent direct: info@serpent.com. The Serpent Facebook, Twitter and Youtube pages give additional means of support and communications.

SAFETY

Read and take note of the 'Read this First section' before proceeding to assemble the car-kit. This car-kit is intended for persons aged 16 or older.

READ THIS FIRST!

- This is a highly technical hobby product, intended to be used in a safe racing environment. This car is capable of speeds in excess of 80 km/h or 50mph. Please follow these guidelines when building and operating this model.
- Parental guidance is required when the builder/user of this car is under 16.
- Follow the building instructions. If in doubt, contact your dealer or importer.
- Be sure to use the proper tools when assembling the car. Always exercise caution when using electric tools, knives and other sharp objects.
- Be careful when using liquids like lubrication oil, fuel or glue. Do not swallow.
- Follow the manufacturer's instruction in case you experience irritation after using the product.
- Be careful when operating the car. Stay away from any rotating parts such as wheels, gears and transmission. Stay away from motor, engine and exhaust pipe system or speedo during and immediately after use, as these parts may be very hot. We advise to use protective hand cloves.
- Only operate this car in a safe environment, like a special racing track or a closed parking lot. Avoid using this car on public roads, crowded places or near infants.
- Before operating this car, always check the mechanical status of the car. Also check that the transmitter and receiver frequencies correspond and are not used by any other racer at the same time. Check that the batteries of the transmitter and receiver- are fully charged.
- After use, always check all the mechanics of the car. We advise to clean the car immediately after use, and inspect the parts for wear or fractures. Replace when necessary. Do not use water, methanol, thinner or other solvents to clean the car.
- Empty the fuel tank (depending on model) if needed and disconnect the receiver battery.
- Store the car in a dry and heated place to avoid corrosion of metal parts.
- Avoid using this car in wet conditions as the water will cause corrosion on the metal parts and bearings and these parts will cease to function properly. If driven in the wet, ensure that all the electric equipment is waterproofed and after use, that all moving parts are dried immediately.

CONTENTS

• FRONT DIFF ASSEMBLY	4
• REAR DIFF ASSEMBLY	6
• REAR ASSEMBLY	8
• GEARBOX ASSEMBLY	13
• FRONT I ASSEMBLY	17
• RADIO ASSEMBLY	20
• FRONT II ASSEMBLY	28
• SHOCKS ASSEMBLY	33
• CLUTCH ASSEMBLY	36
• FINAL ASSEMBLY	39
• EXPLODED VIEWS	42
• TEAM SERPENT NETWORK	52

LINES DESCRIPTION

Each step contains a variety of numbers, lines, and symbols. The numbers represent the order in which the parts should be assembled. The lines are described below.



Step number; the order in which you should assemble the indicated parts



Length after assembly



Assembly path of one item into another



Group of items (within lines) should be assembled first



Direction the item should be moved



Glue one item to another



Press/Insert one item into another



Connect one item to another



Gap between two items

ICONS DESCRIPTION

Each step contains a variety of symbols described below.



Carefull, read and check very well.



Apply a small amount of cyano glue. Use wear protection for eyes and hands.



Detail view to explain assembly or order of parts better.



Default set-up: This symbol indicates the default setup.



Grease: apply a small amount of grease to the parts shown.



Silicone grease: apply a small amount of grease to the parts shown.



Left and right parts should be assembled in the same way.



Thread lock: apply a small amount on the parts shown. Before to apply the threadlock, make sure to degrease the parts very well, as otherwise the threadlock will not work.



Silicone oil: use the indicated silicone oil for the shocks and differentials.



Parts or items not included in the kit.



Optional part, not standard in the kit.

STEP 1 FRONT DIFF BAG

1.1

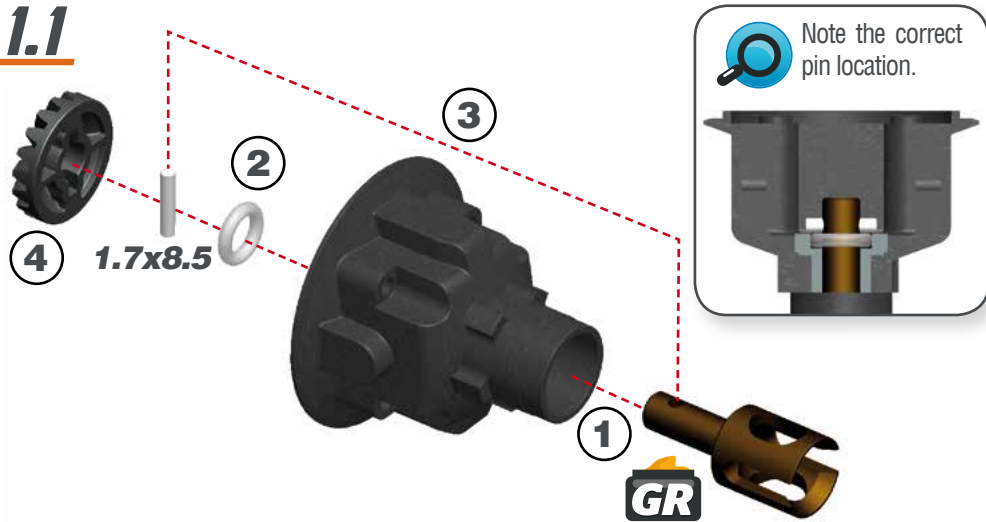

1.2

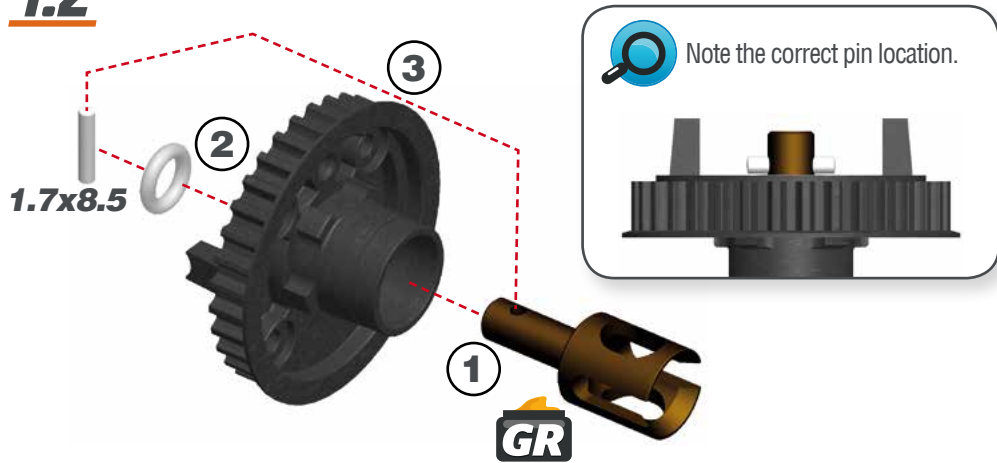

1.75x8.5

STEP 2

2.1

Add just enough oil to cover the large gear before assembling the small satellite gears and cross pins.

For the correct cst value please check the default setupsheet.



2.2

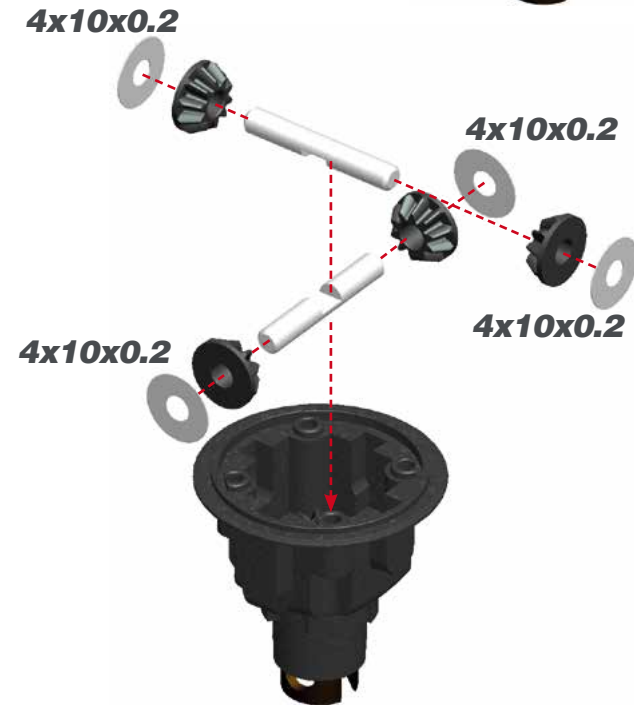

4x10x0.2

STEP 3

3.1

! Fill the differential with silicone oil 1 mm above the crosspin, do NOT overfill. For the correct cst value please check the default setupsheet.



3.2

! Add the big gear.

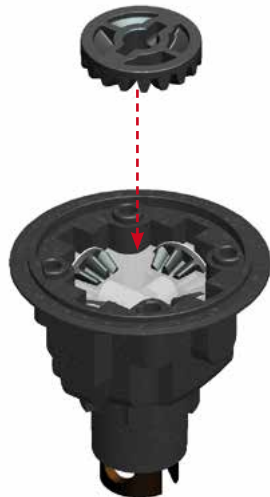

STEP 4



Mount the diff top-case on the lower case, make sure to follow below Detail View, and tighten the screws.

M2.5x10

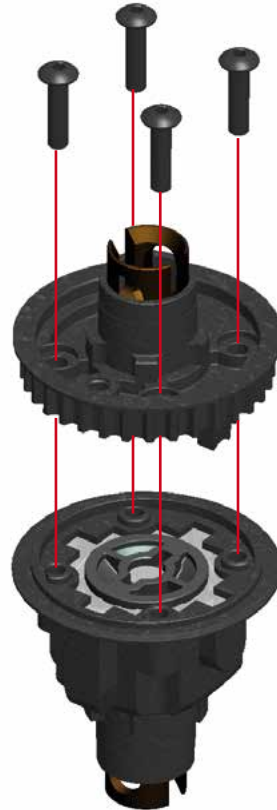

HOW TO CLOSE THE FRONT DIFF

The front diff top case has two protrusions (see below picture in red) to hold the gear/diff shafts in the correct position. The two protrusions press on the upper shaft and thus secure the shafts in position.

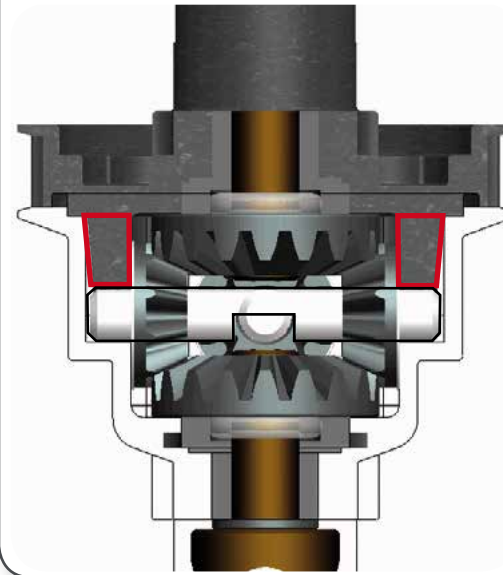

1- Allow the excess of oil to escape through the escape hole.

2- Close the hole with the 3x3 setscrew. Tighten carefully.

3- In case the diff feels too hard remove the M3x3 set screw and let some oils to escape and colse again. Tighten carefully.

M3x3

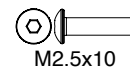

STEP 6 REAR DIFF BAG

6.1

Note the correct pin location.

1.7x8.5

GR

6.2

Note the correct pin location.

1.7x8.5

GR

1.75x8.5

STEP 7

7.1

Add just enough oil to cover the large gear before assembling the small satellite gears and cross pins.

For the correct cst value please check the default setupsheet.



7.2

4x10x0.2

4x10x0.2

4x10x0.2

4x10x0.2

4x10x0.2

STEP 8

8.1

! Fill the differential with silicone oil 1 mm above the crosspin, do NOT overfill. For the correct cst value please check the default setupsheet.



8.2

! Add the big gear.

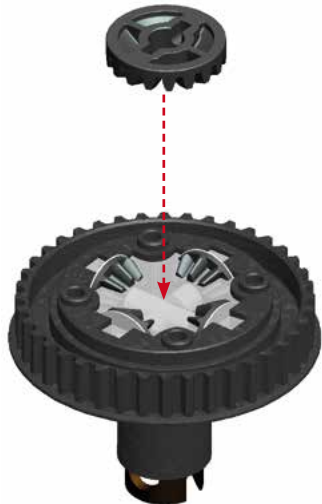

STEP 9



1- Fit the o-ring (see detail view picture in yellow) in the slot of the bottom case using some silicone oil to hold it in position.

2- Mount the diff top-case on the lower case, make sure to follow below Detail View, and tighten the screws.

M2.5x10

2

1

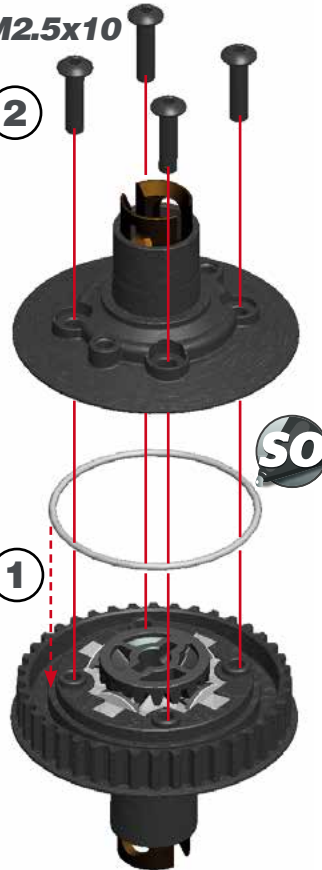

HOW TO CLOSE THE REAR DIFF

The rear diff top case has two protrusions (see below picture in red) to hold the gear/diff shafts in the correct position. The protrusion should hold the upper shaft as it will hold the bottom shaft.

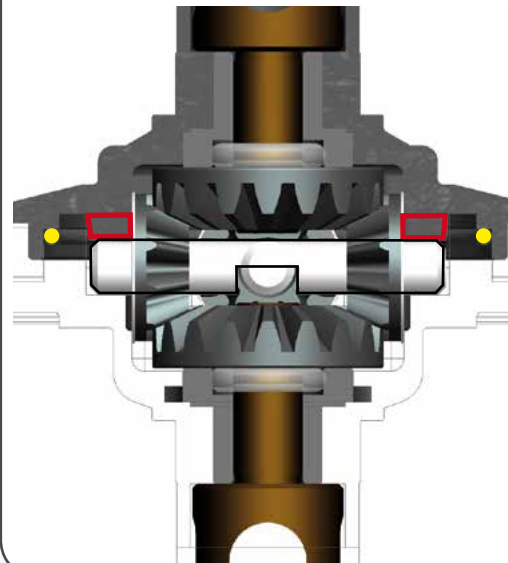

STEP 10



1- Allow the excess of oil to escape through the escape holes.

2- Close the holes with the 3x3 setscrews. Tighten carefully.

3- In case the diff feels too hard remove the M3x3 setscrews and let some oils to escape and colse again. Tighten carefully.

M3x3

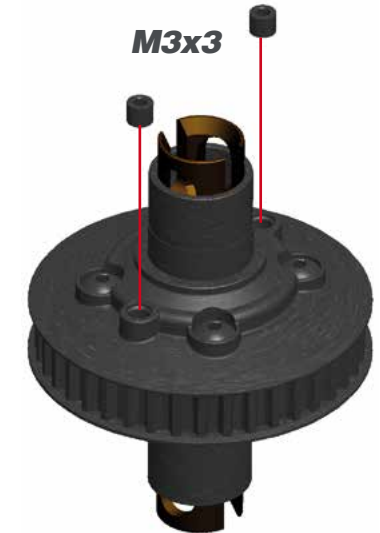

STEP 11 **BAG 1**

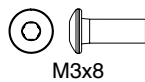
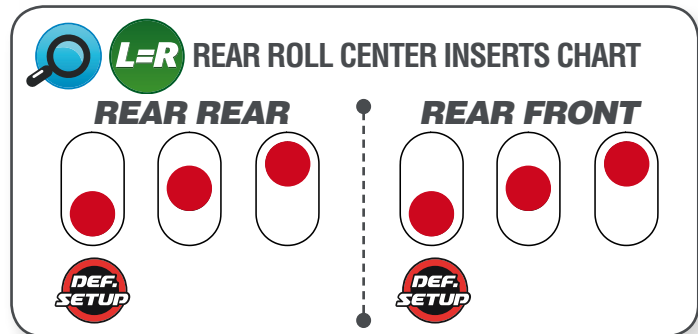
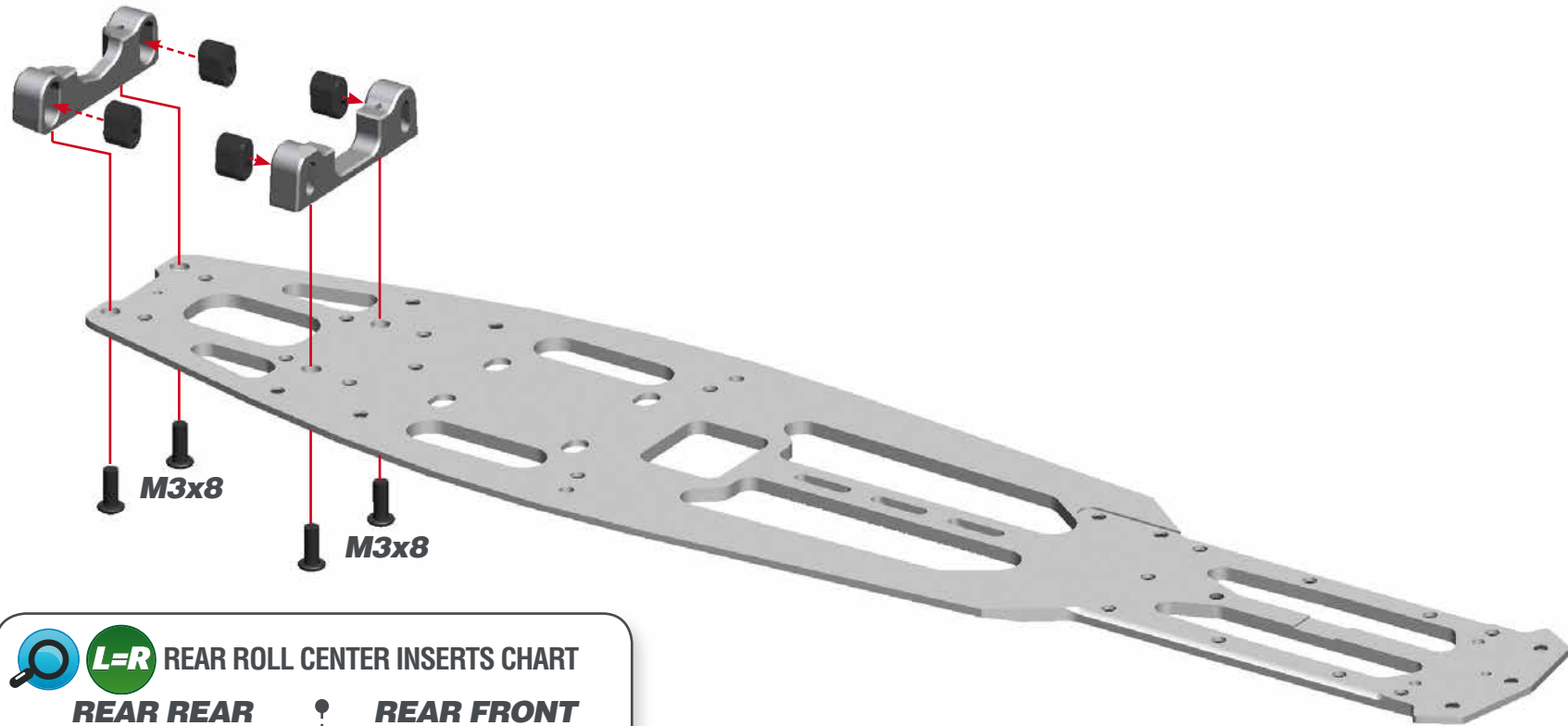





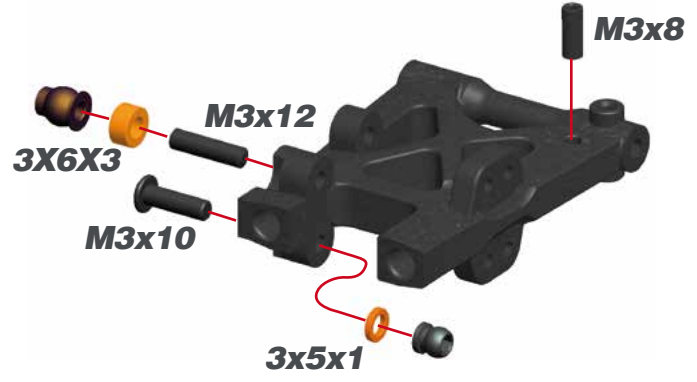

STEP 12

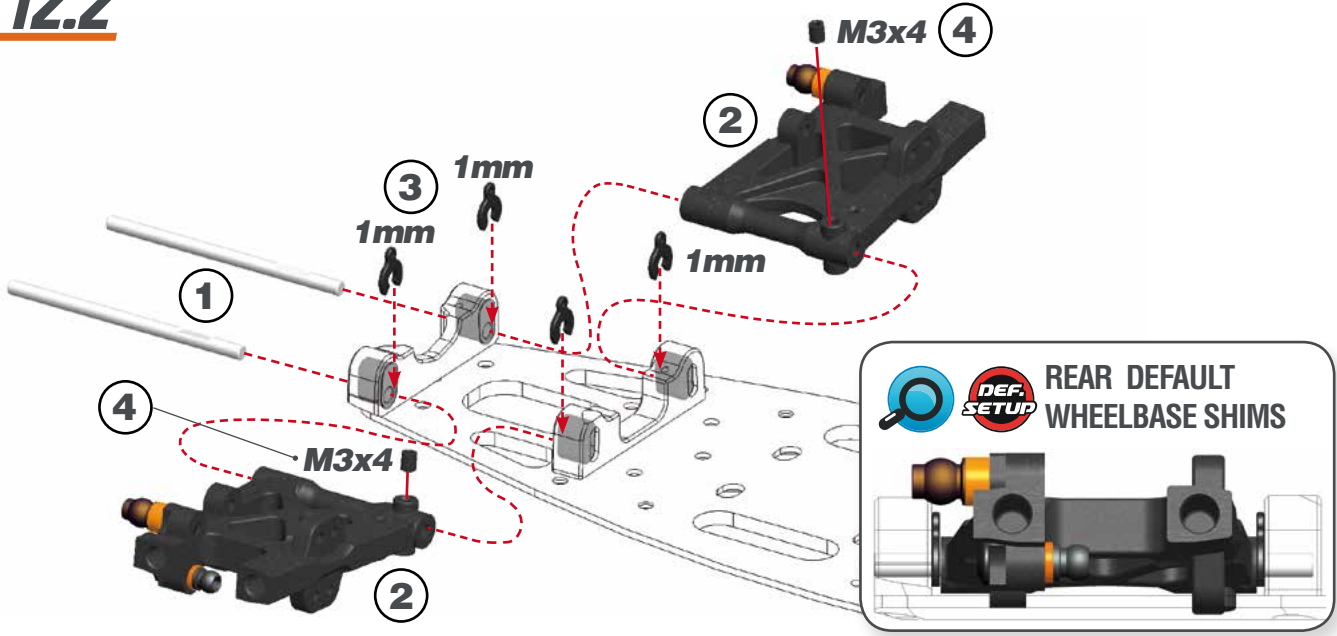
12.1



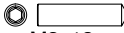
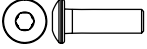



12.2

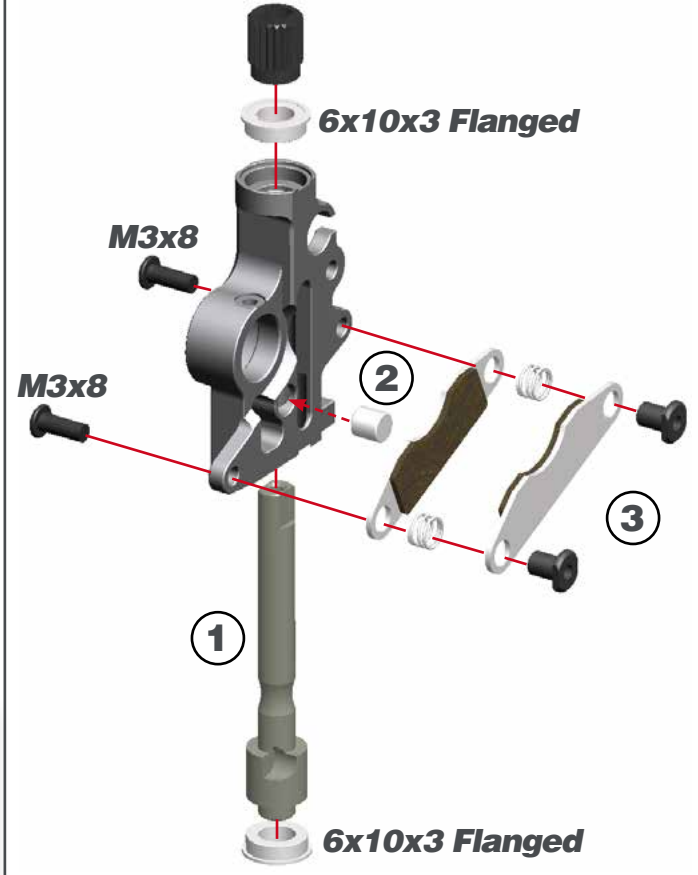

-  M3x8
-  M3x12
-  M3x10
-  M3x4
-  3x5x1
-  3x6x3

STEP 13 **BAG 2**



-  M3x8
-  6X10X3 Flanged
-  5x5

STEP 14

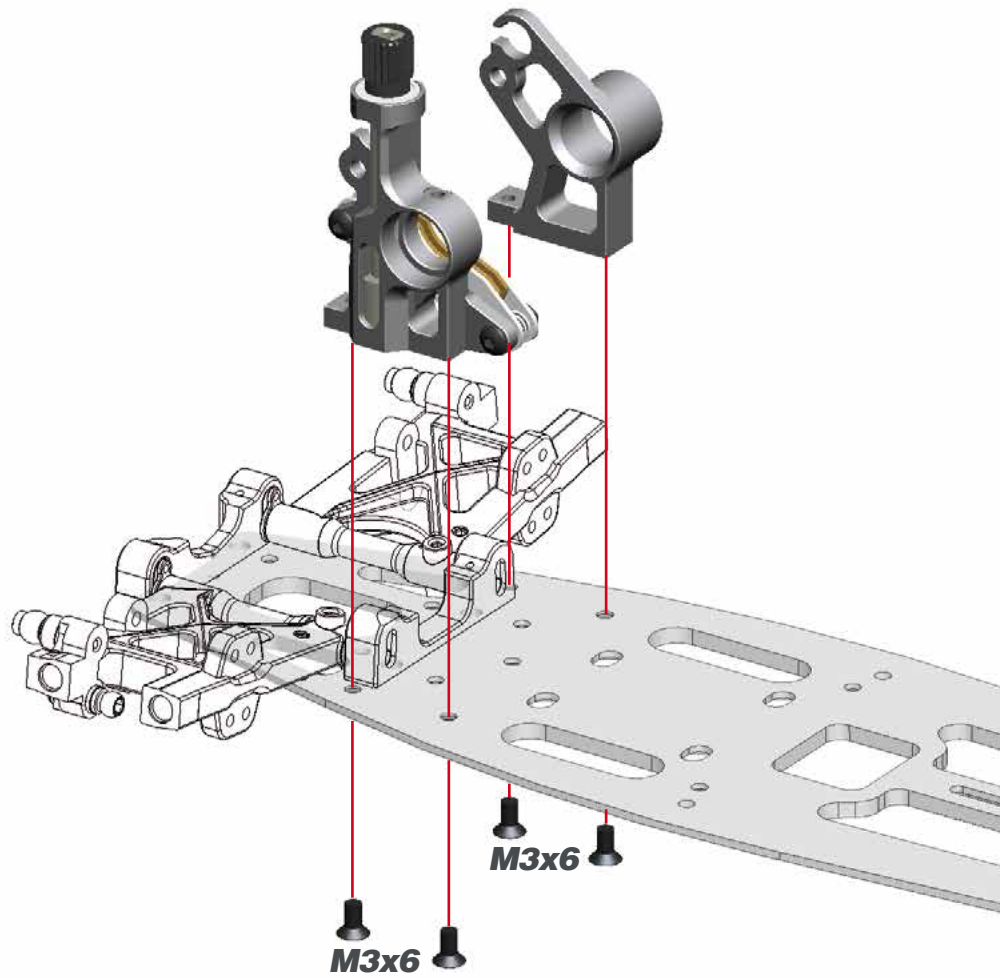

STEP 15

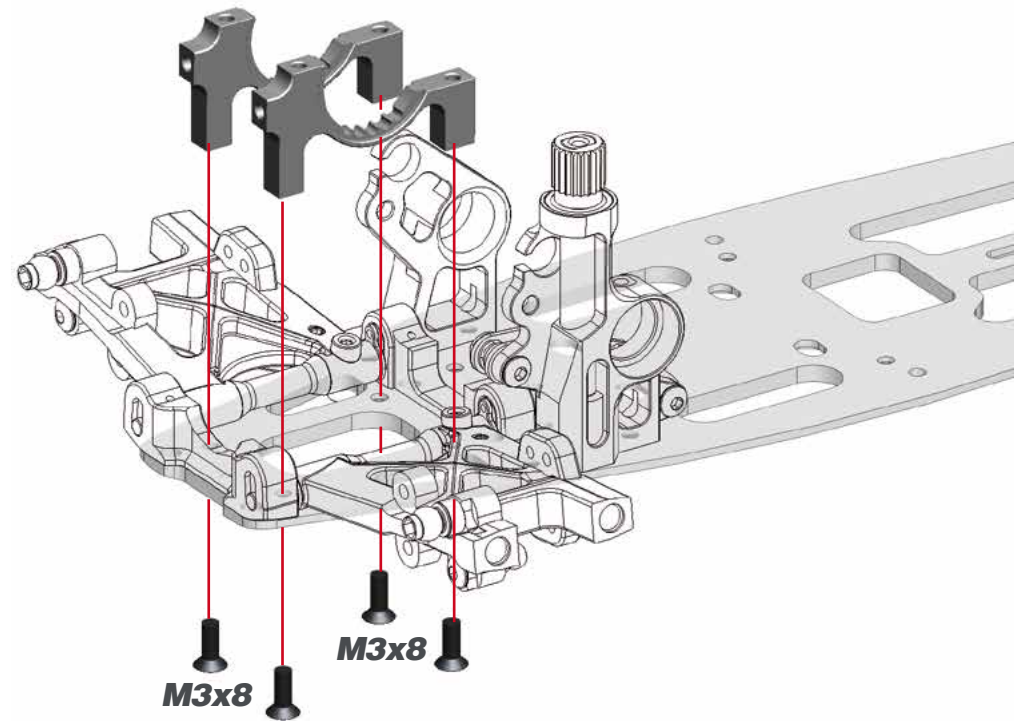

STEP 16

16.1

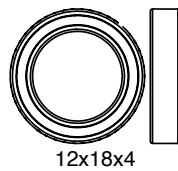
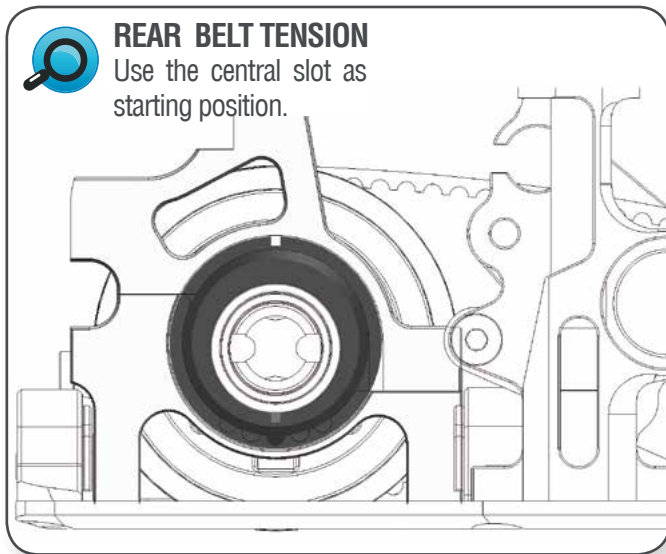
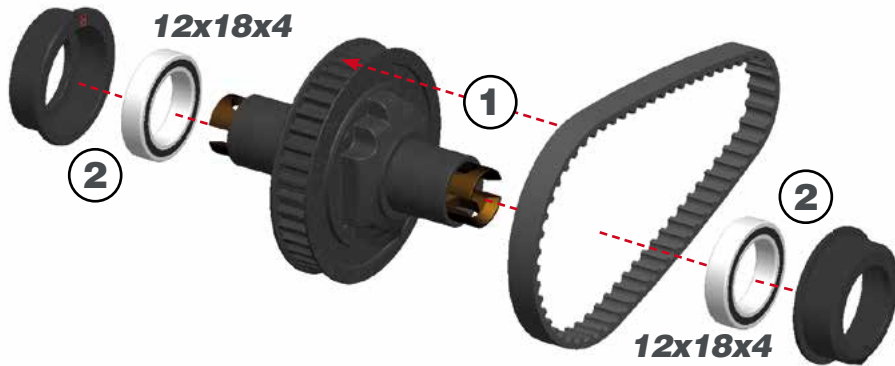

16.2

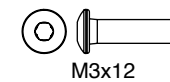
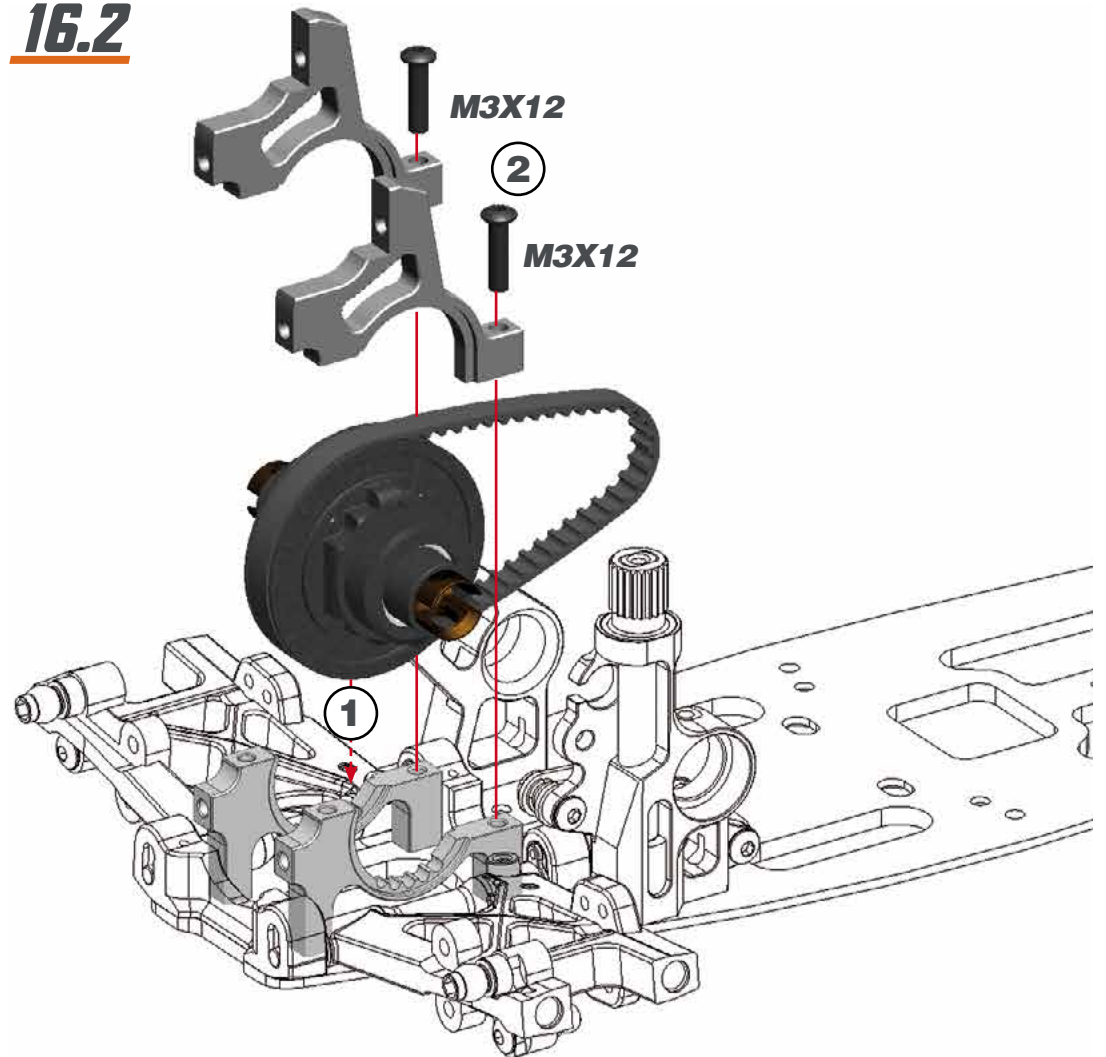

STEP 17 **BAG 3**

17.1

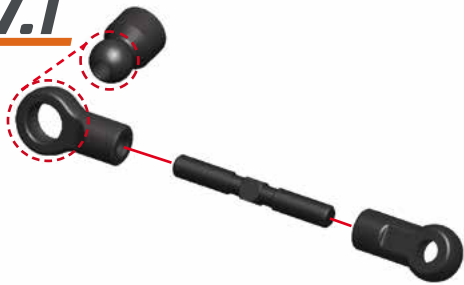

17.2

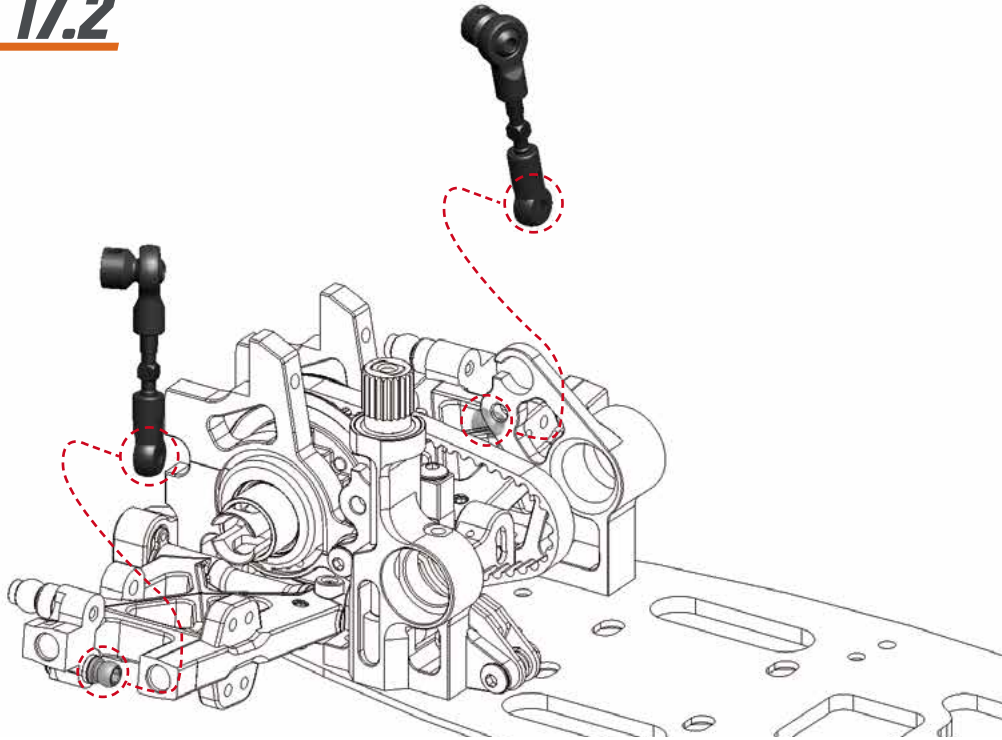

STEP 18

18.1



18.2

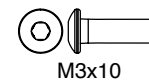
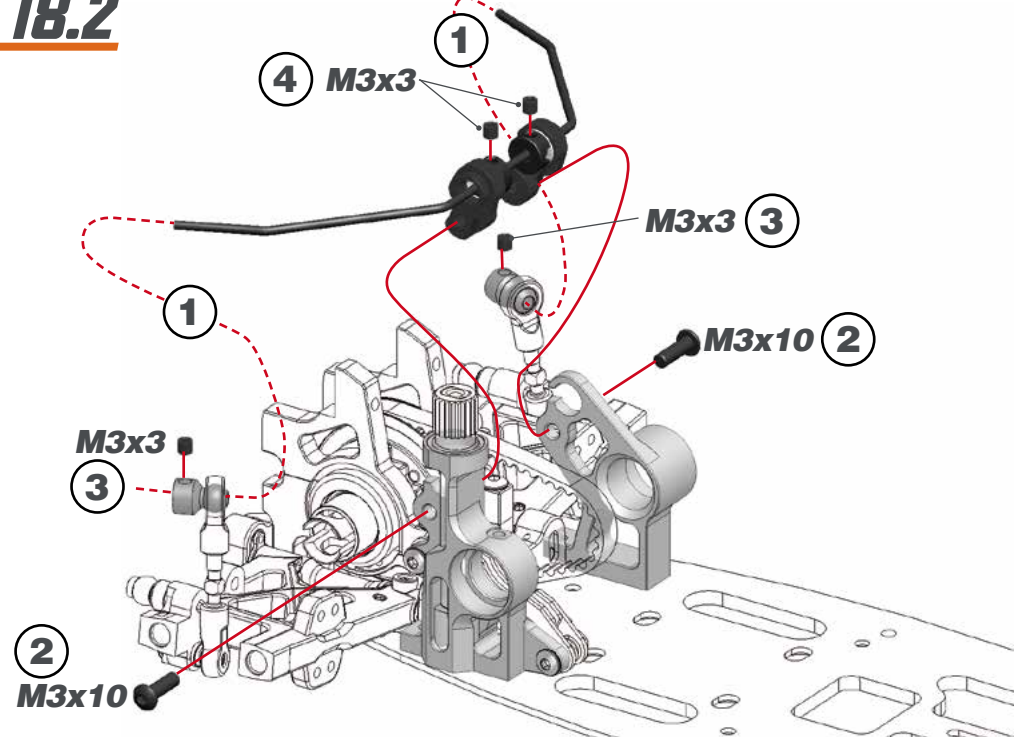

STEP 19

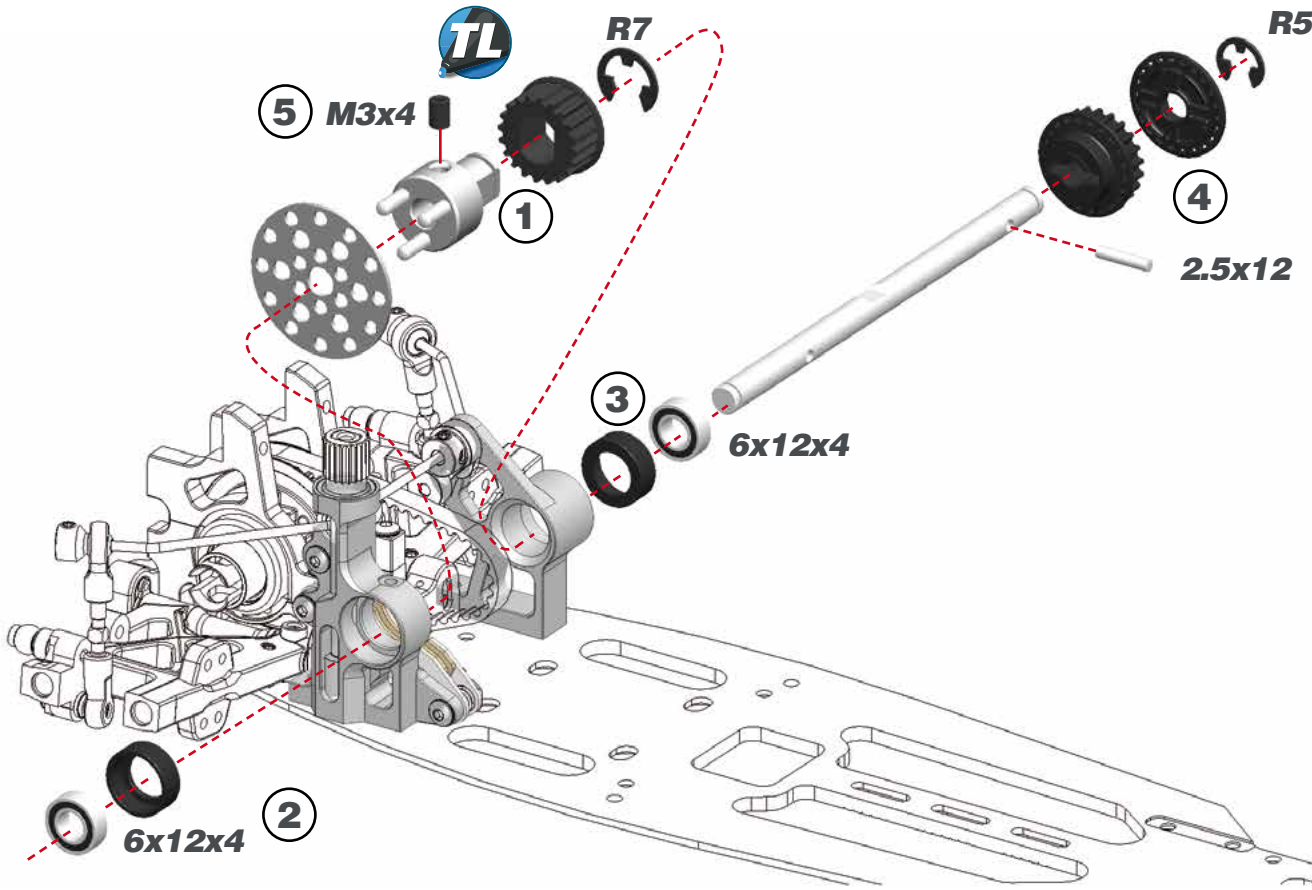

STEP 20

20.1

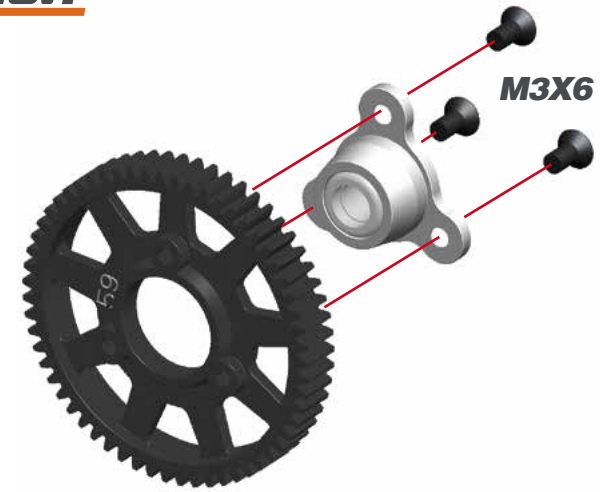

20.2

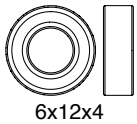
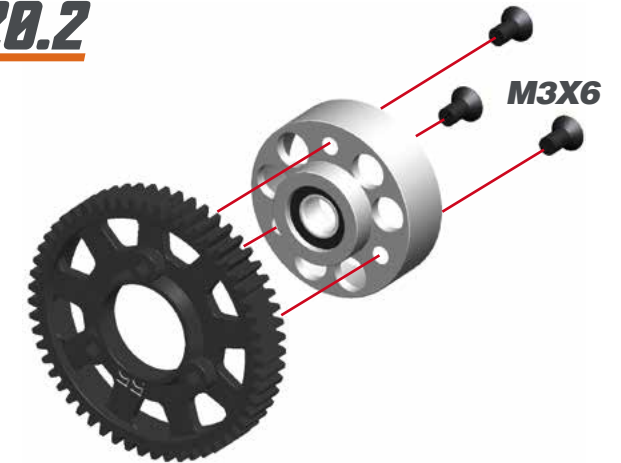

6x12x4



2.5x12



M3x4



R5



R7



M3x6

STEP 21

21.1

! For being able to assemble the M3x3 setscrew from the inside the first step is to pre-do a 2mm deep thread in the plastic shoe by the inside. After doing the thread please remove the set screw.



M3x3

! Note the correct thread depth.

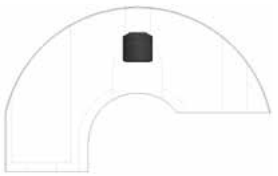

21.2

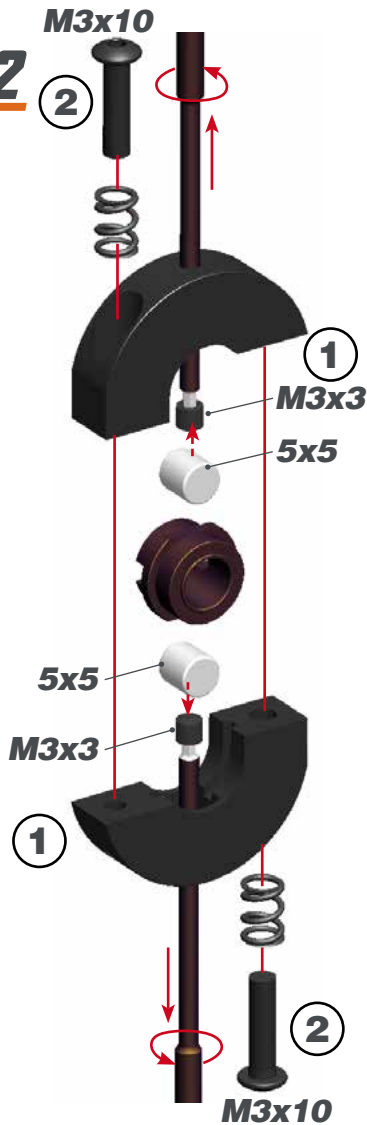

M3x10

2

1

M3x3

5x5

5x5

M3x3

1

2

M3x10



1- Assemble the M3x3 setscrew from the inside of the gearbox unscrewing it. Use the 5x5 cylinder for helping the set screw going inside the hole. Do not unscrew the M3x3 screw completely. 2- The M3x10 screw adjust the SHIFT POINT. As default adjustment screw it in all the way (do not over tighten the spring deforming it), then unscrew 3 turns. 3- Adjust the M3x3 screw to minimise the gap between the shoes to the bell. Check regularly.

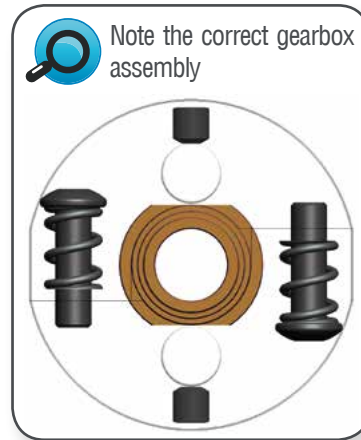

21.3

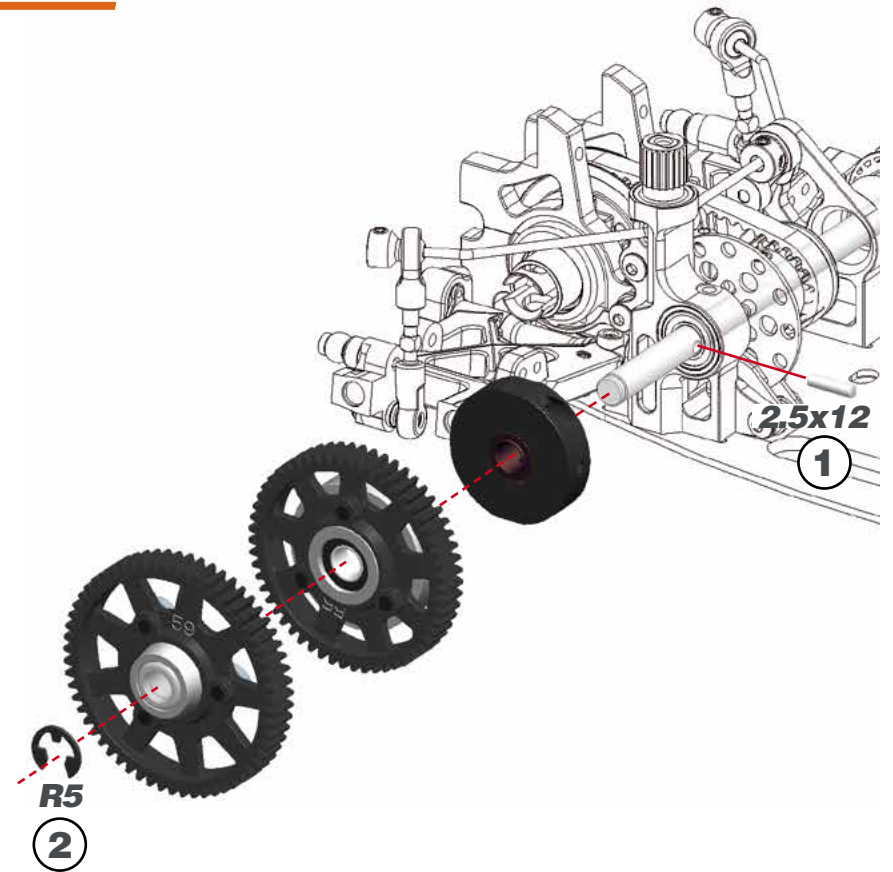

2,5x12

1

R5

2



M3x3



5x5



M3x3



M3x10



R5



2.5x12

STEP 22 **BAG 4**

22.1

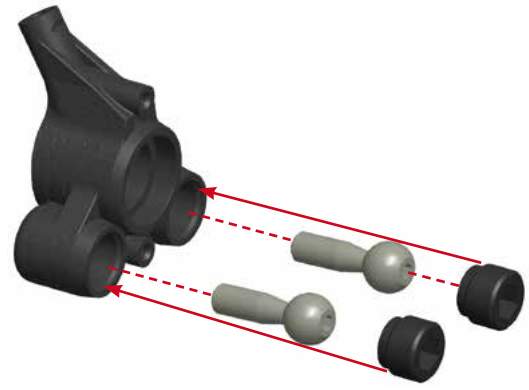

22.2

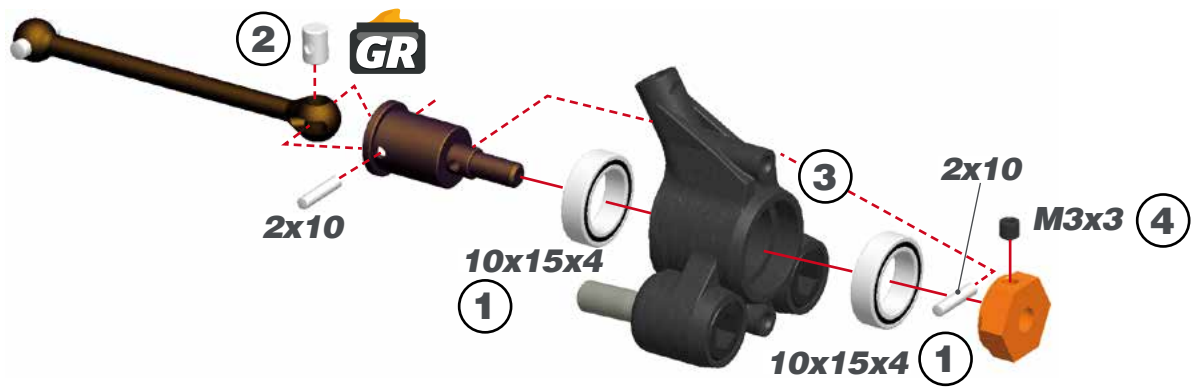

22.3

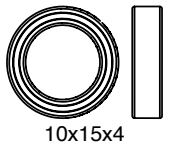
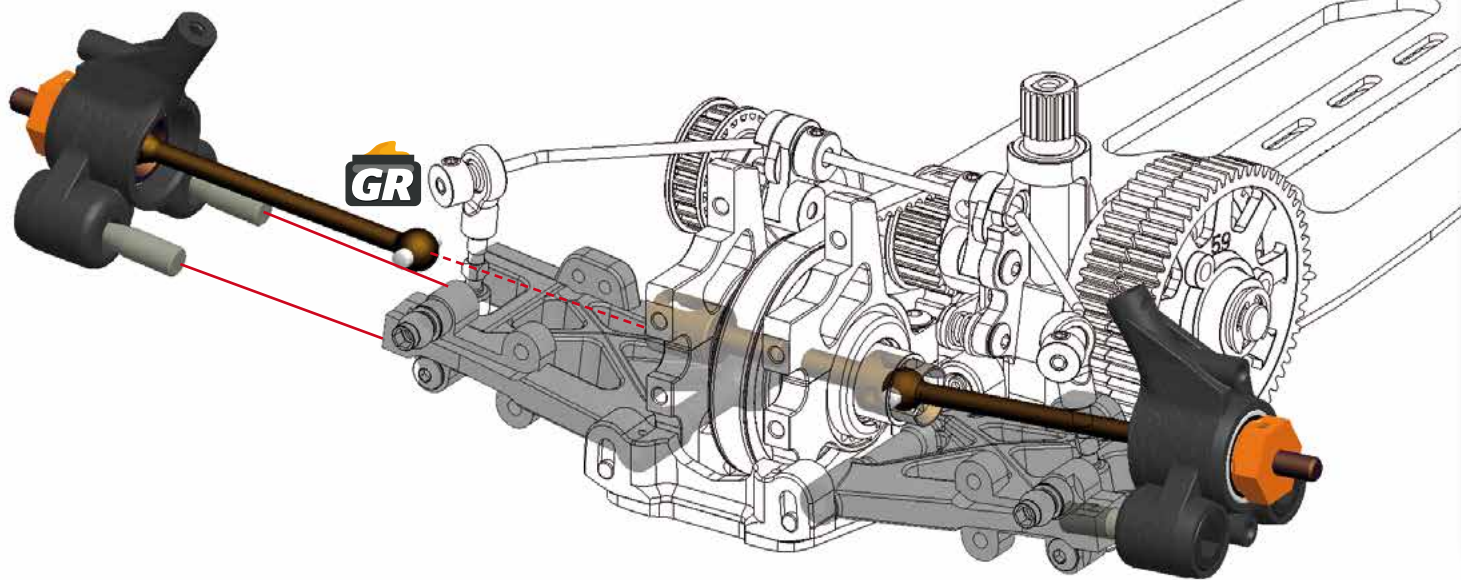

2x10

M3x3

STEP 23

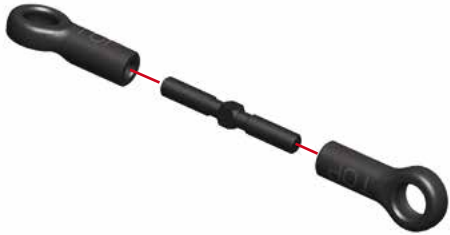

23.1

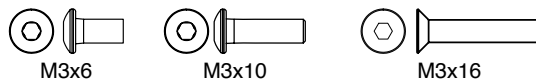
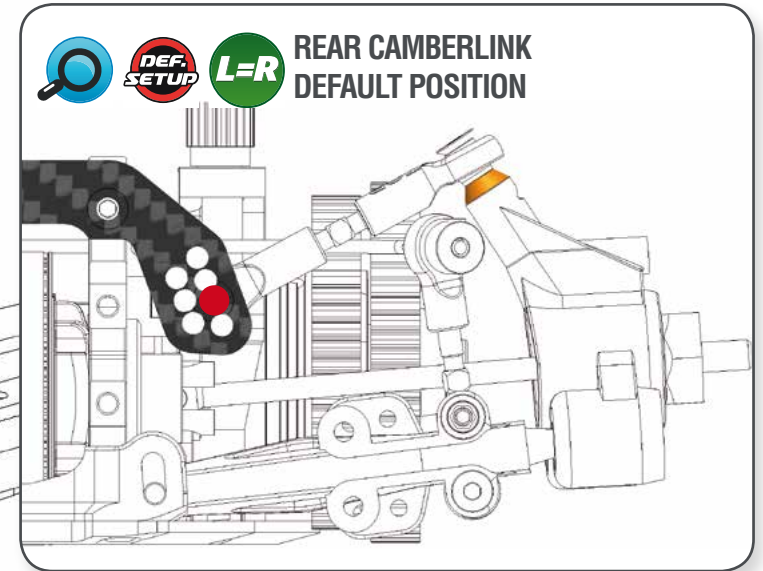
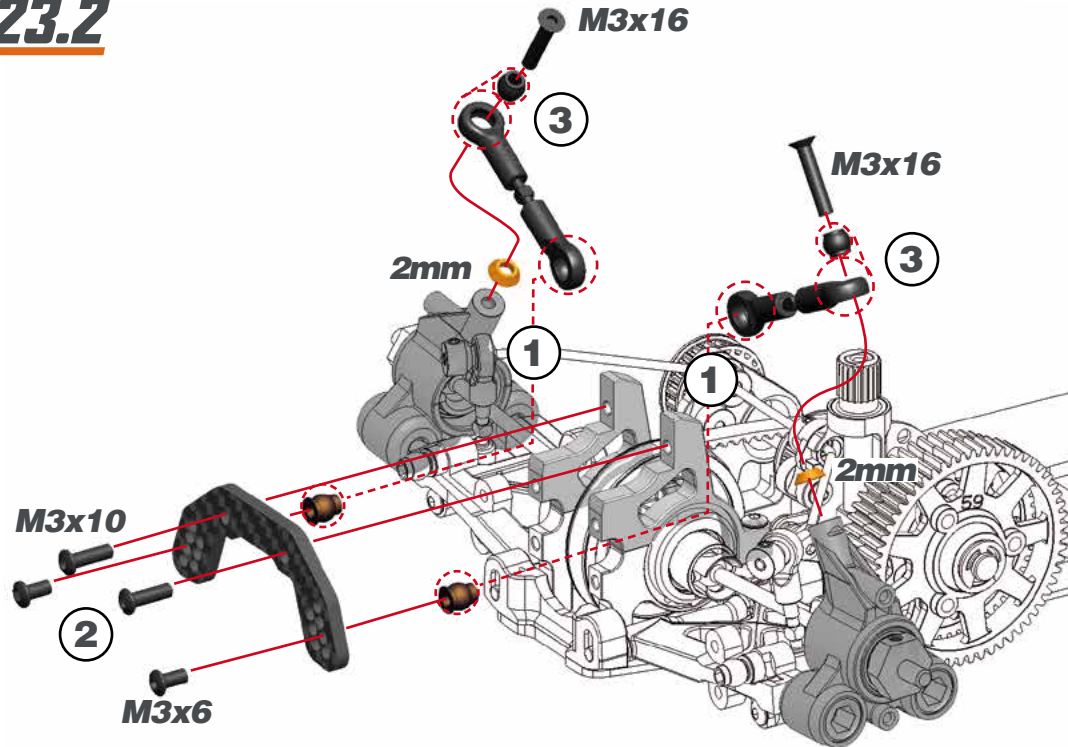

23.2



STEP 24 **BAG 5**

  Note that the front suspension brackets are not symmetric. Check below the correct orientation

RIGHT **LEFT**

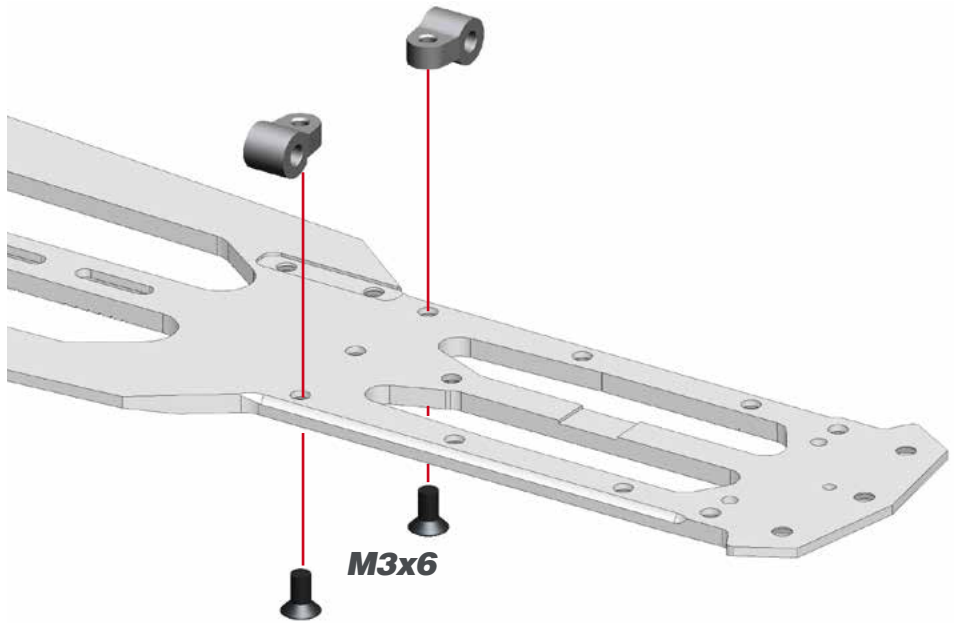
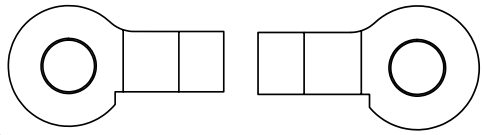

M3x6

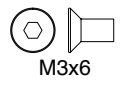

STEP 25

 Note that the front bearing blocks are not symmetric

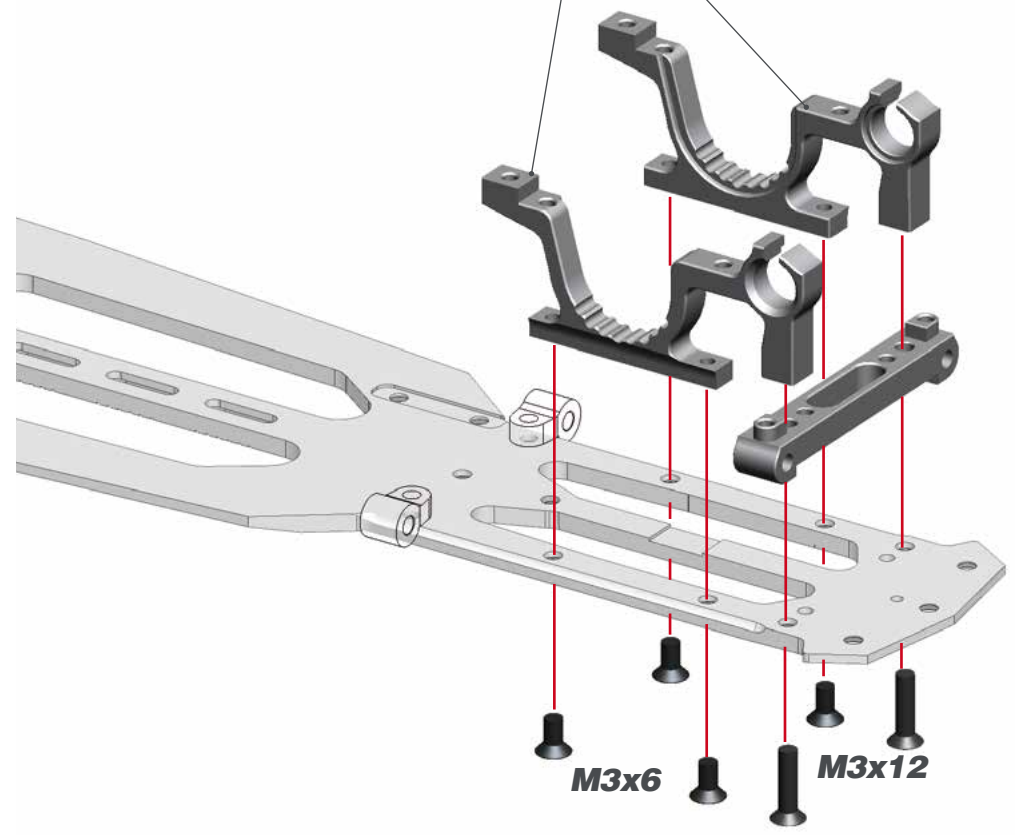

M3x6

M3x12

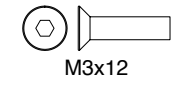

STEP 26



FRONT DEFAULT WHEELBASE SHIMS

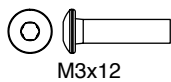
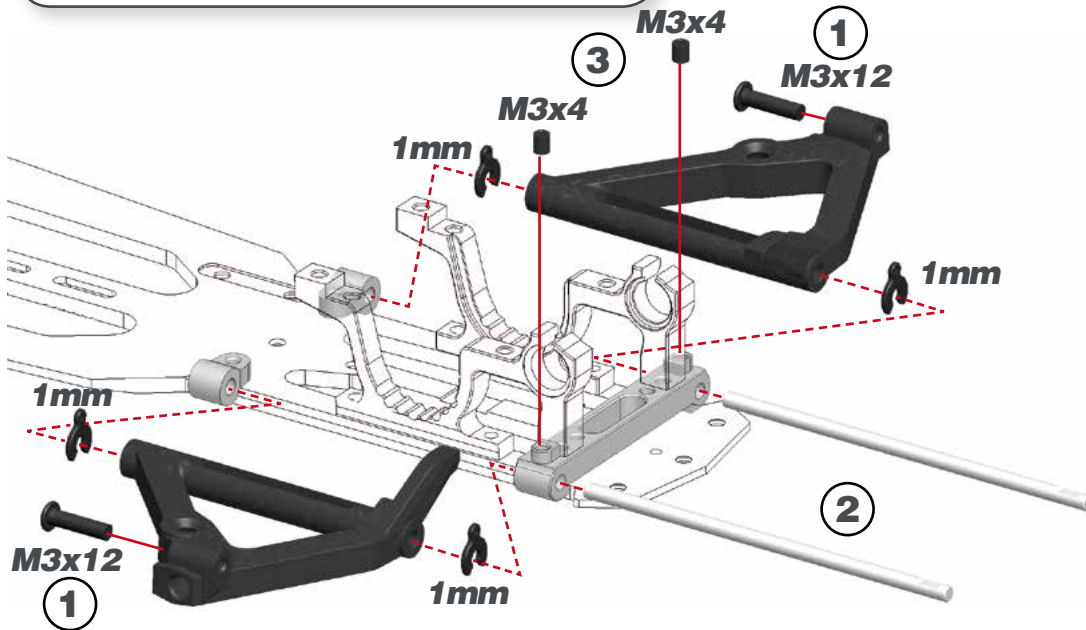
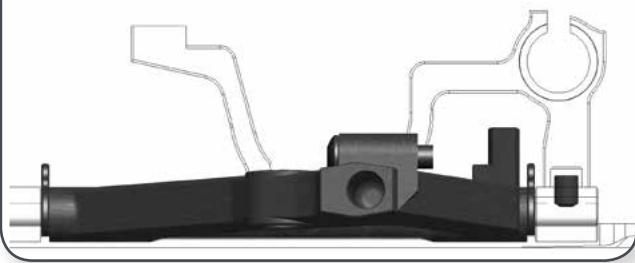

STEP 27 **BAG 6**

27.1

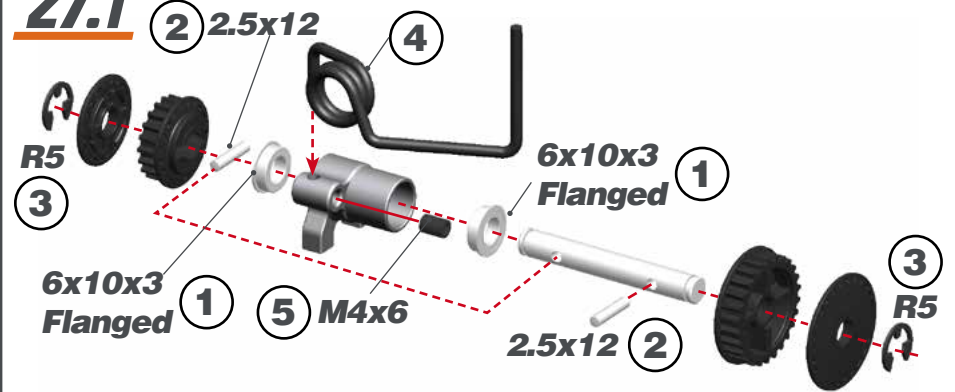

27.2

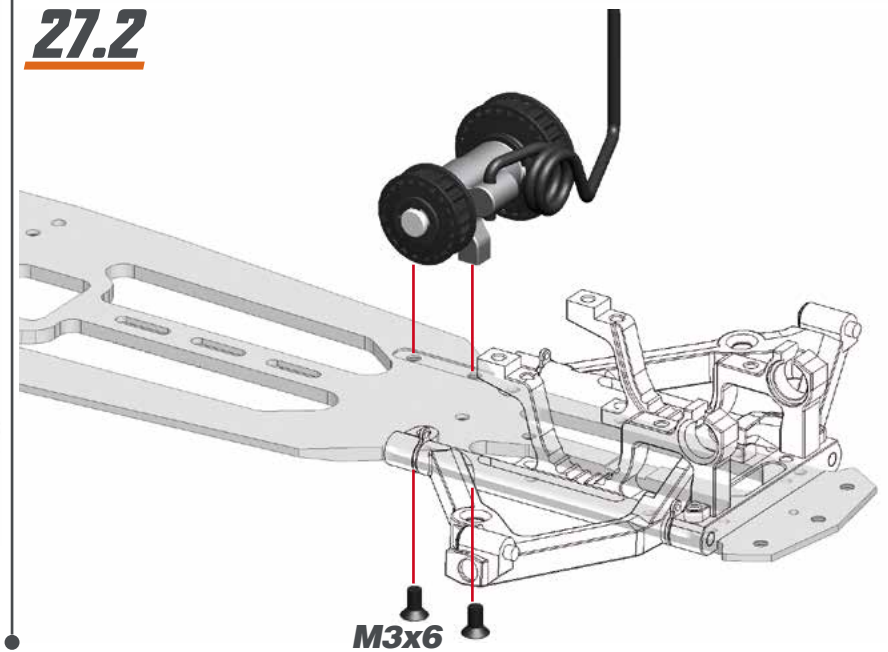

STEP 28

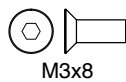
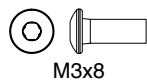
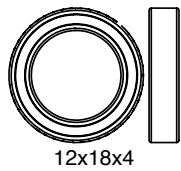
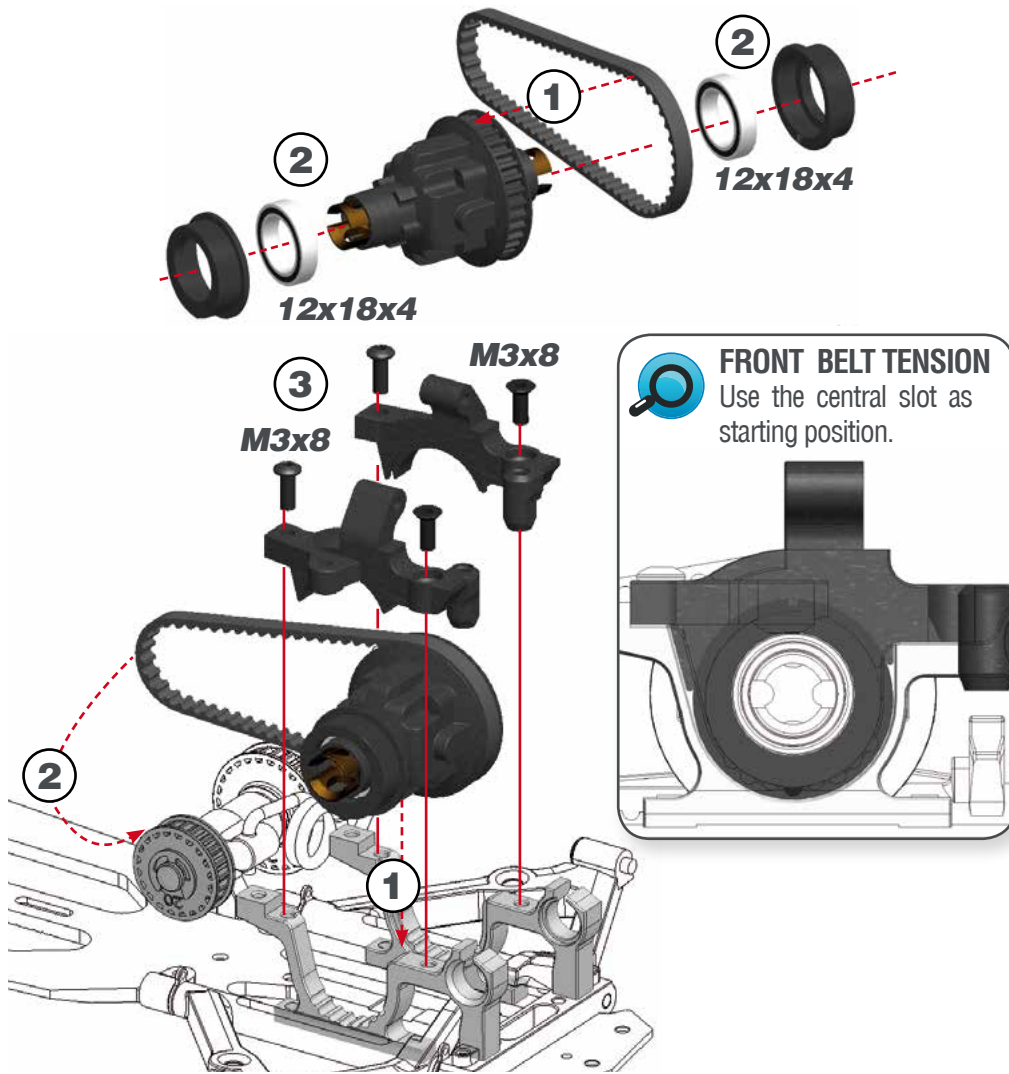

STEP 29

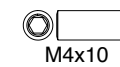
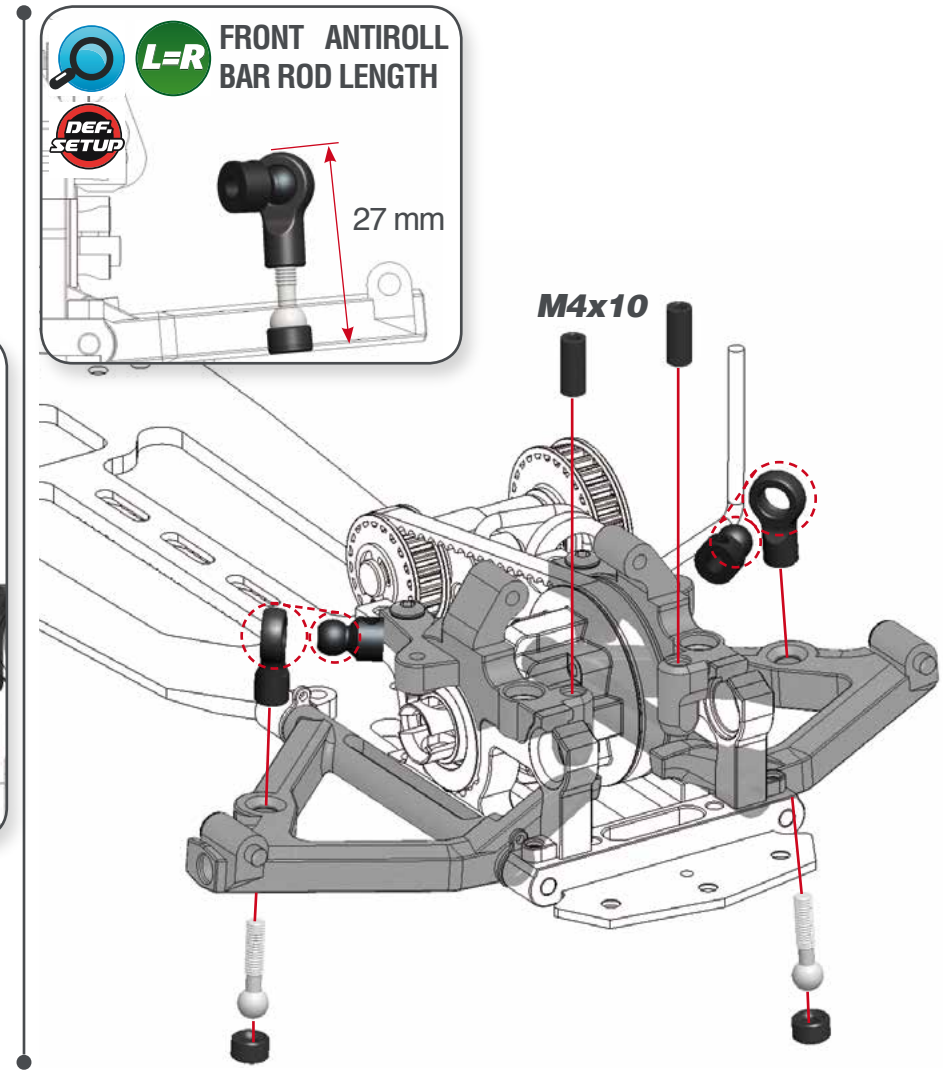

STEP 30

30.1

5x8x2.5 Flanged



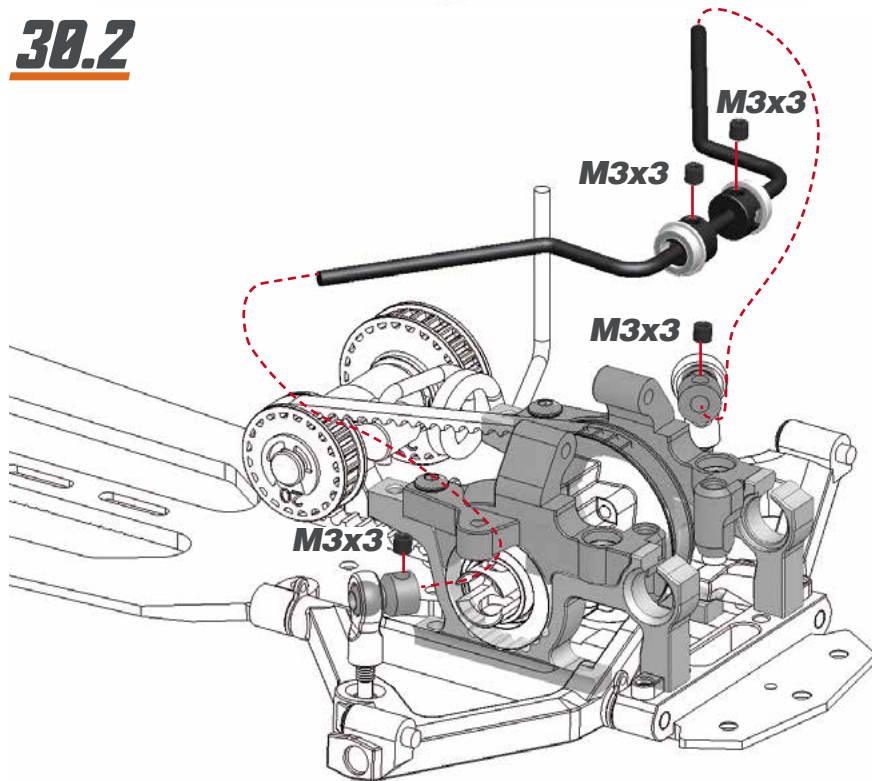

30.2

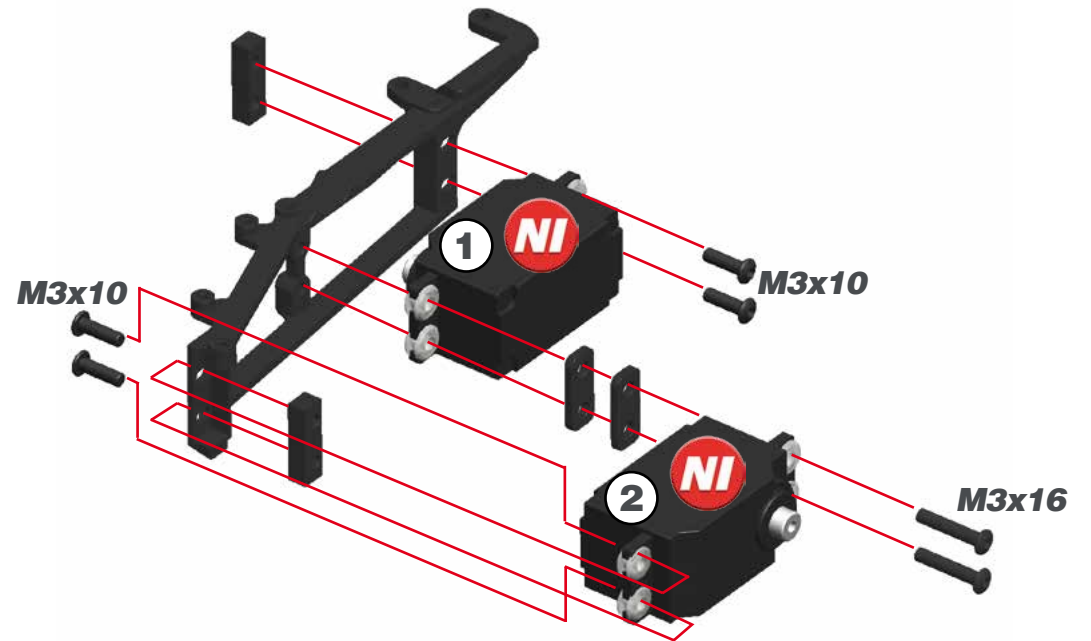

STEP 31 BAG 7



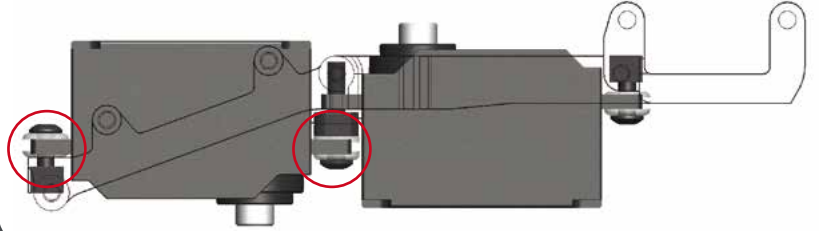
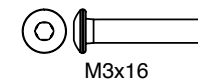
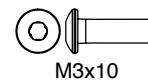

  Note the position of the steering servo "ears". Each one is in one side of the radio box.

STEP 32

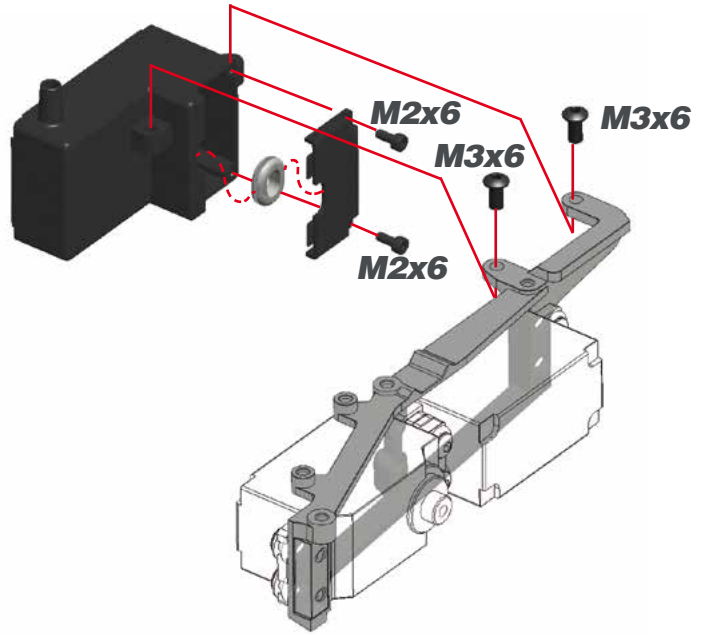

  **SERVO'S WIRE DIAGRAM**

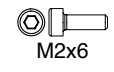
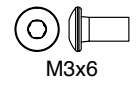

STEP 33

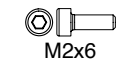
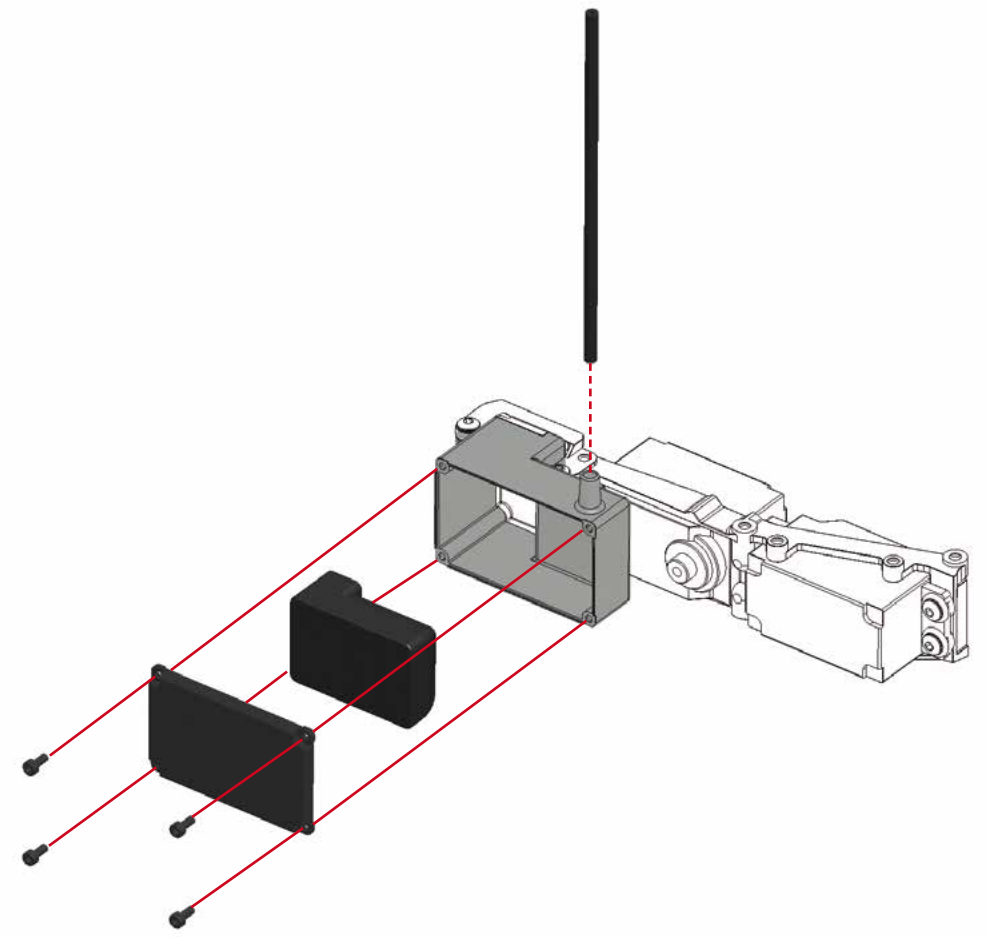

STEP 34



Check how many teeth your servo spline has (23, 24 or 25) and use the right levers.



Note correct pivot ball type.



M3x5

M3x6



Note correct pivot ball type.



M3x6

M3x6



M3x5



M3x6

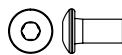

M3x6

STEP 35

35.1



M3x10



THROTTLE LINK LENGTH
Between different servo brands there can be slight differences.

1.5 - 2 mm



STEERING LINK LENGTH
Between different servo brands there can be slight differences.

9.7 - 10.3 mm

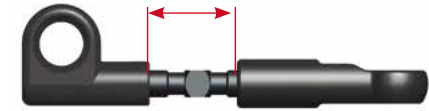

35.2

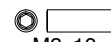
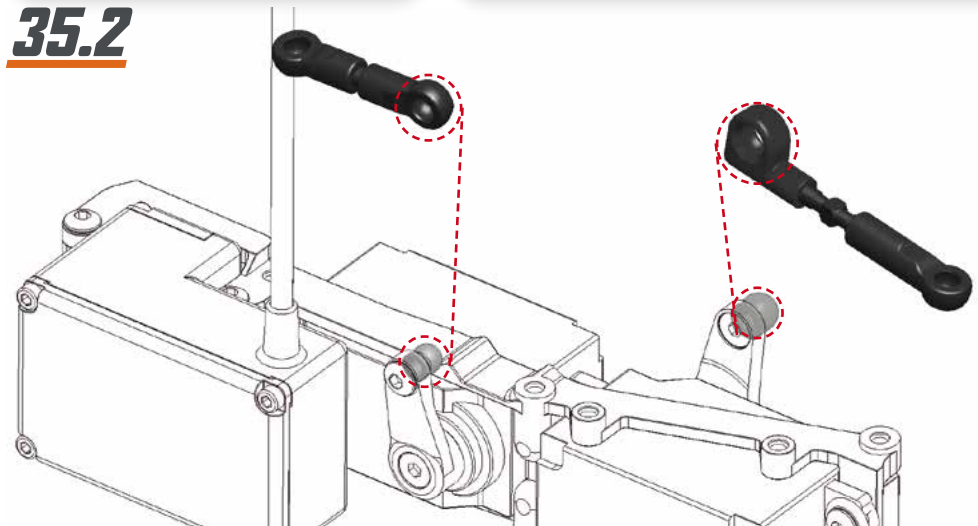

M3x10

STEP 36 **BAG 8**



NOTE: When using Nimh or some Life receiver batteries, it is needed to raise the fuel tank 2mm adding 2mm shims between the fuel tank mountings and the radio plate.

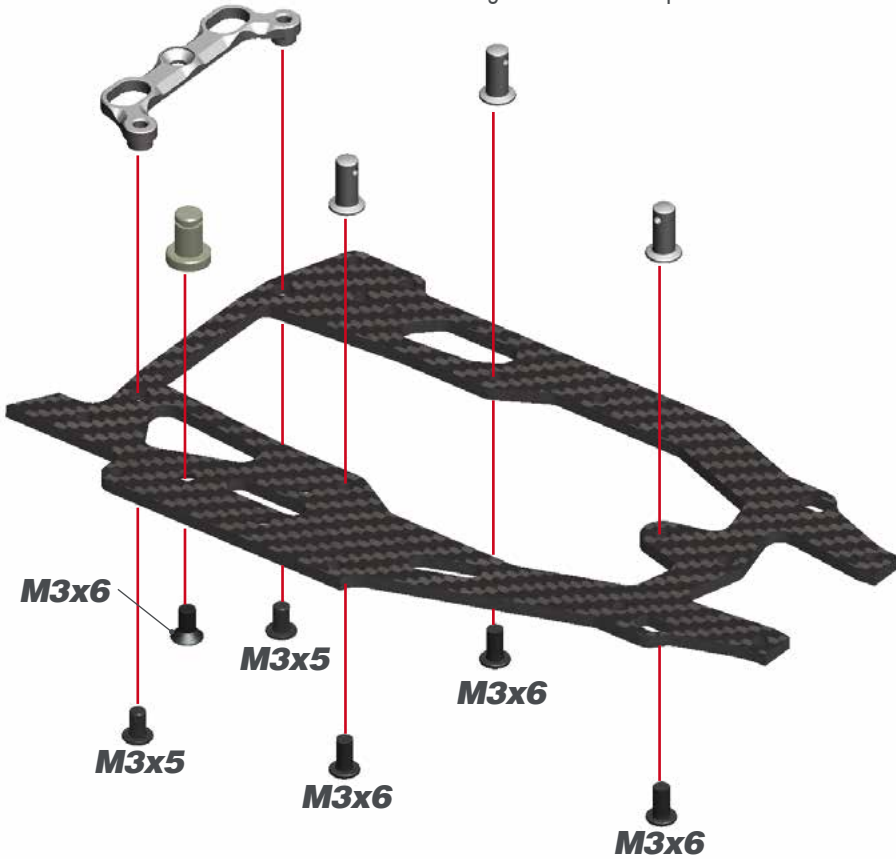

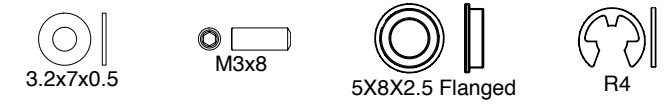
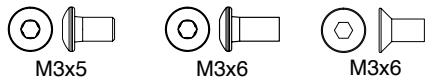
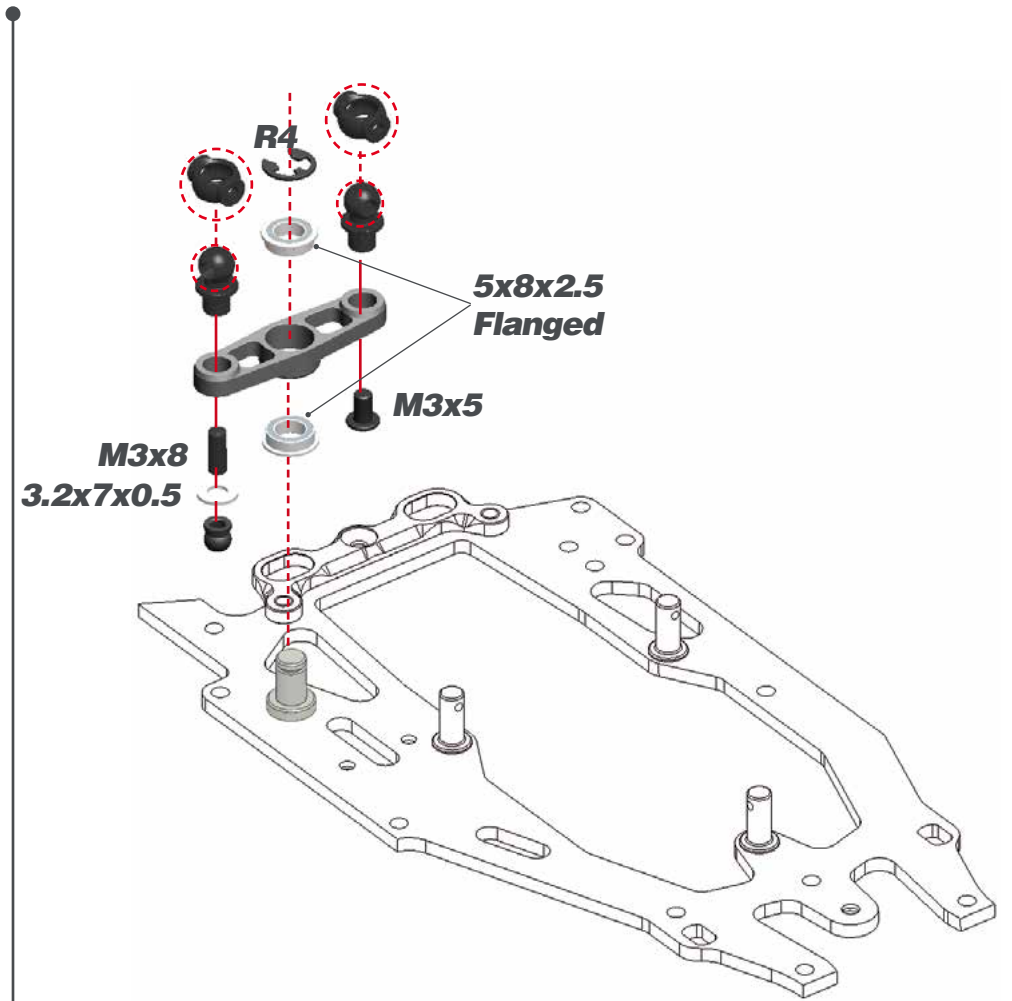

STEP 37

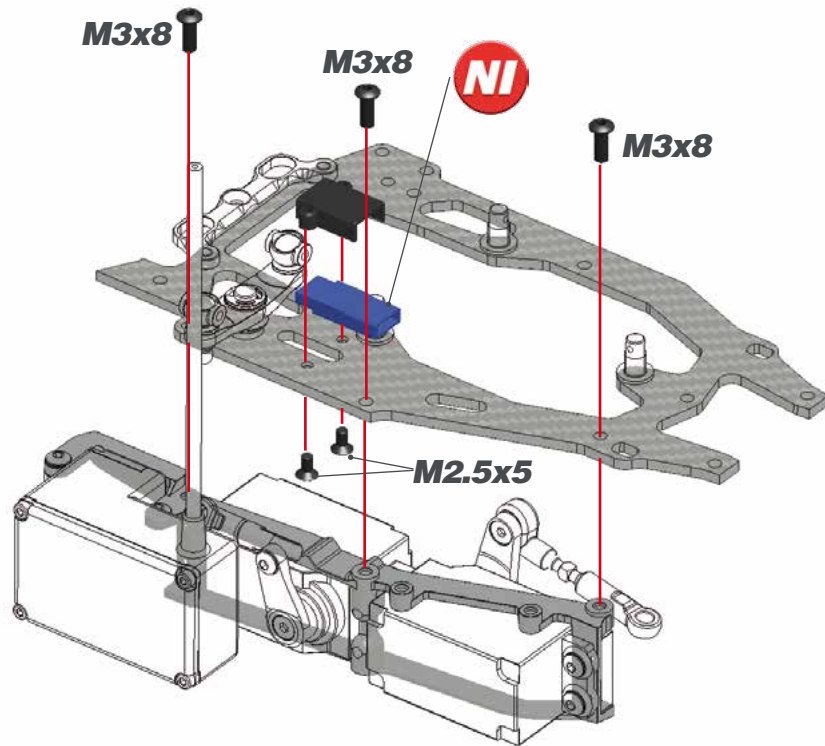

STEP 38



  Note the receiver's power input wire diagram

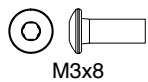

STEP 39

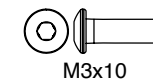
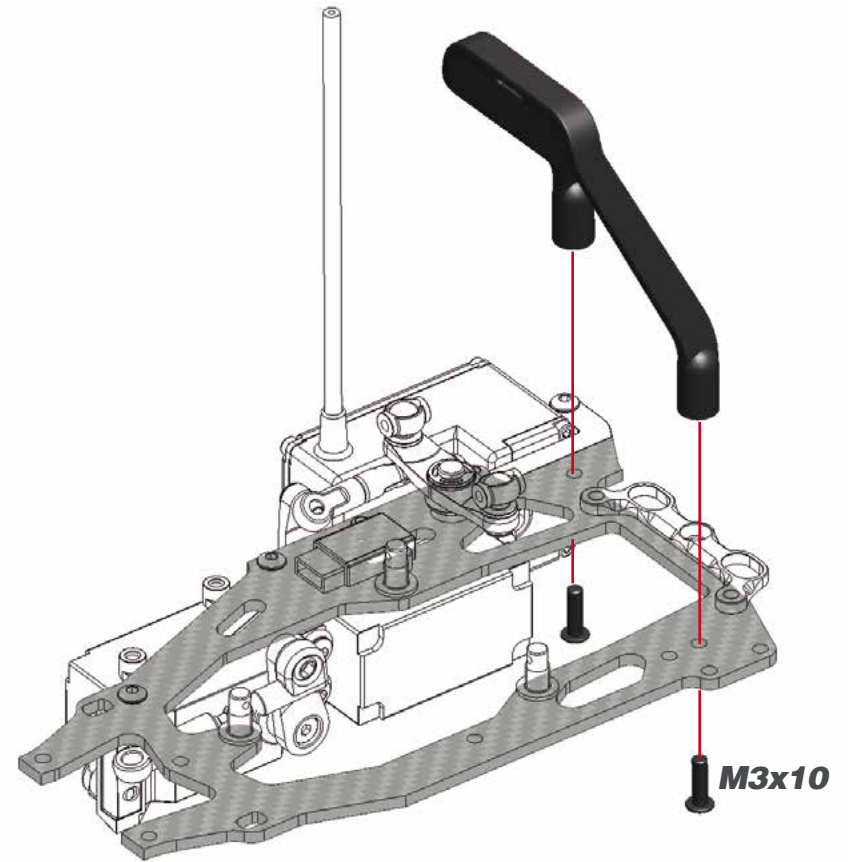

STEP 40

40.1

 Use tape to mount the battery to the carbon support.

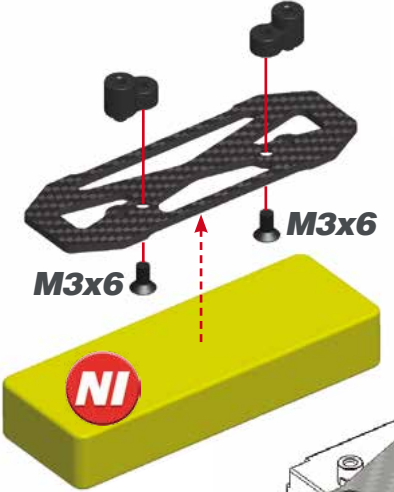

40.2

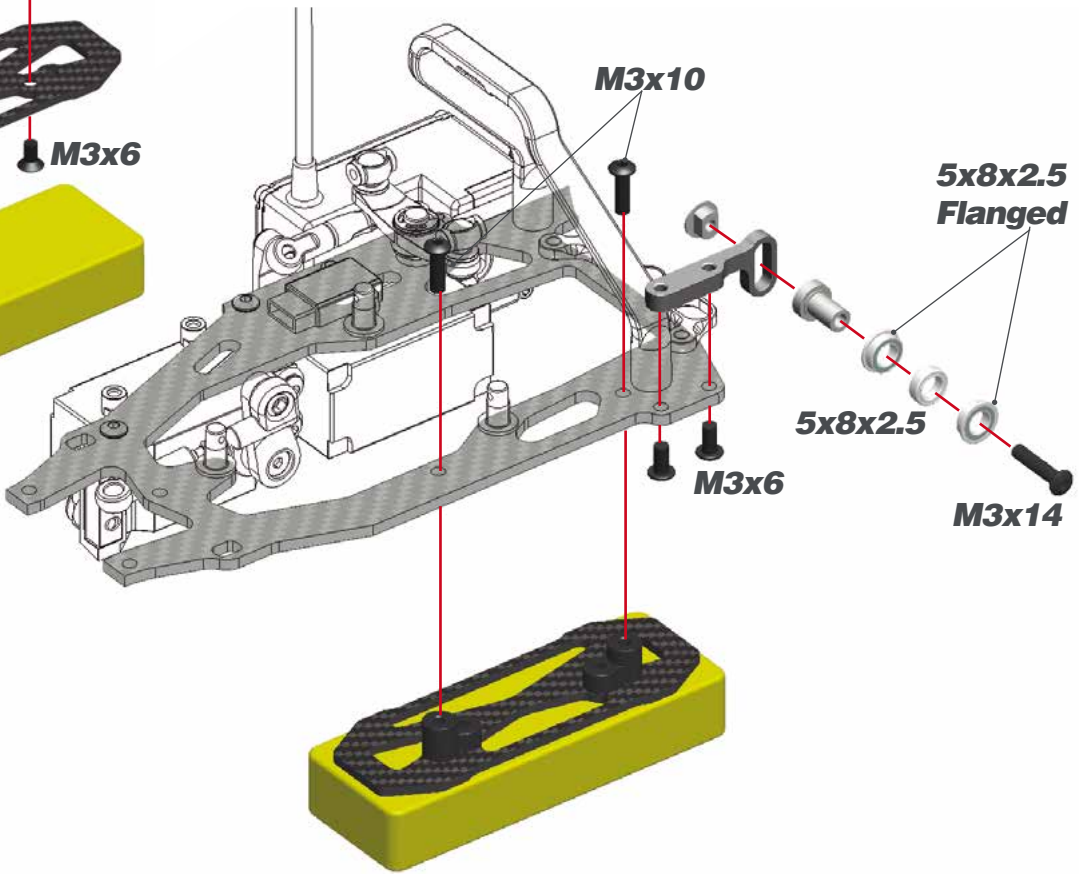

STEP 41

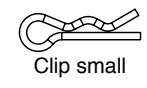
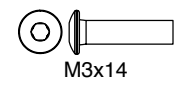
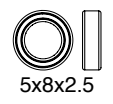
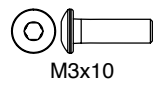
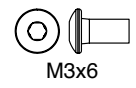
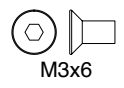
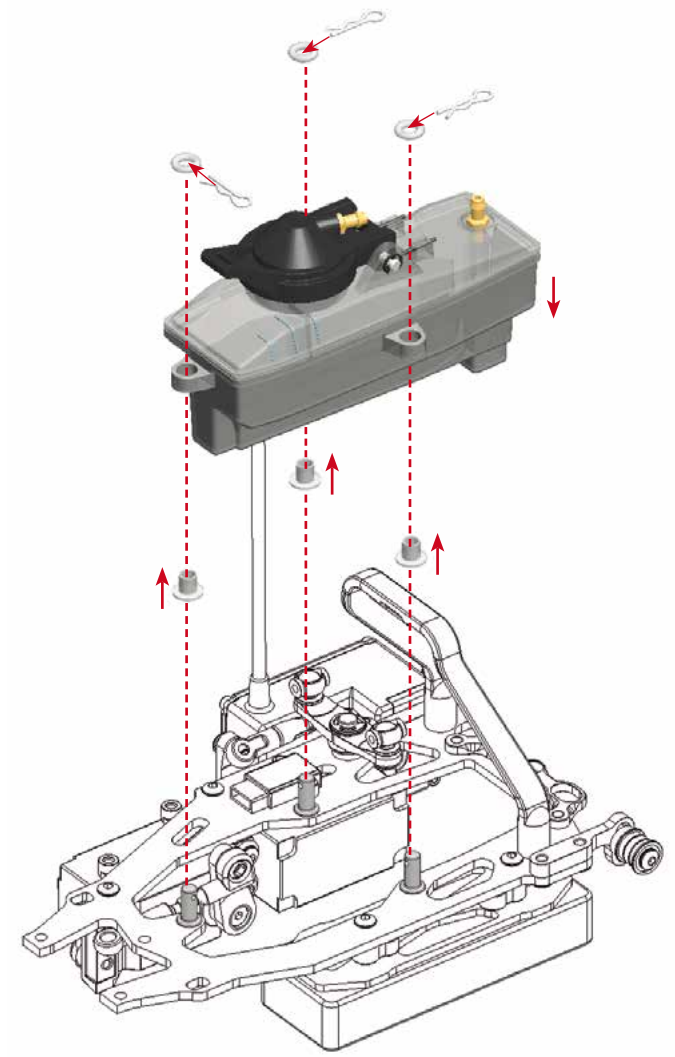

STEP 42 **BAG 9**

42.1

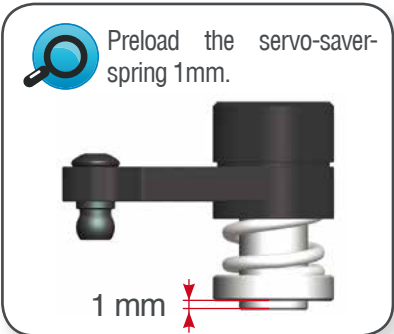

SERVO SAVER ACKERMANN INSERTS

		FORWARD NARROW	
		REARWARD NARROW	
		FORWARD WIDE	
		REARWARD WIDE	

42.2

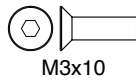
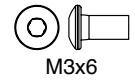
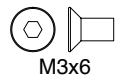
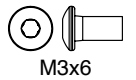
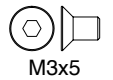
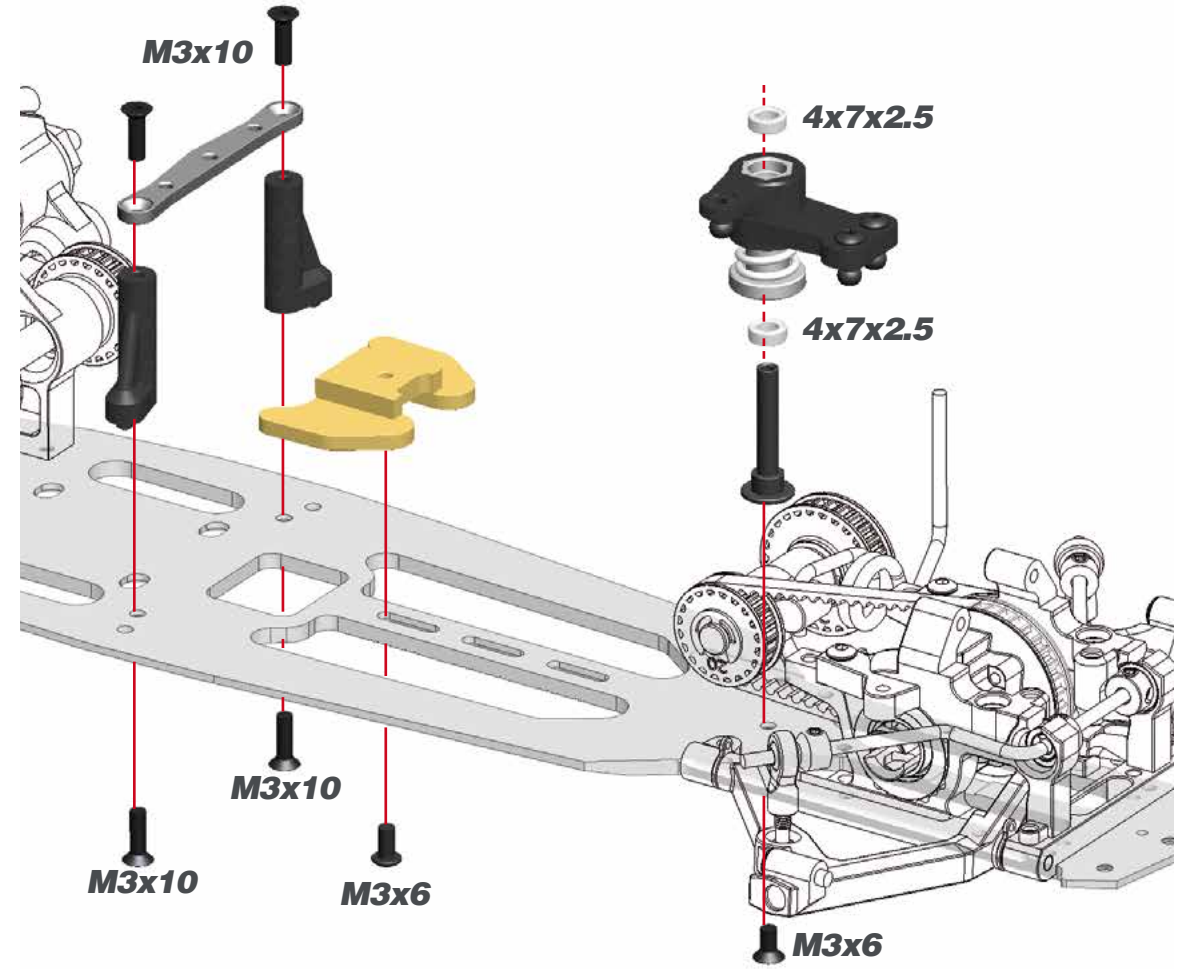

STEP 43

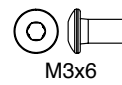
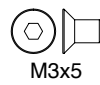
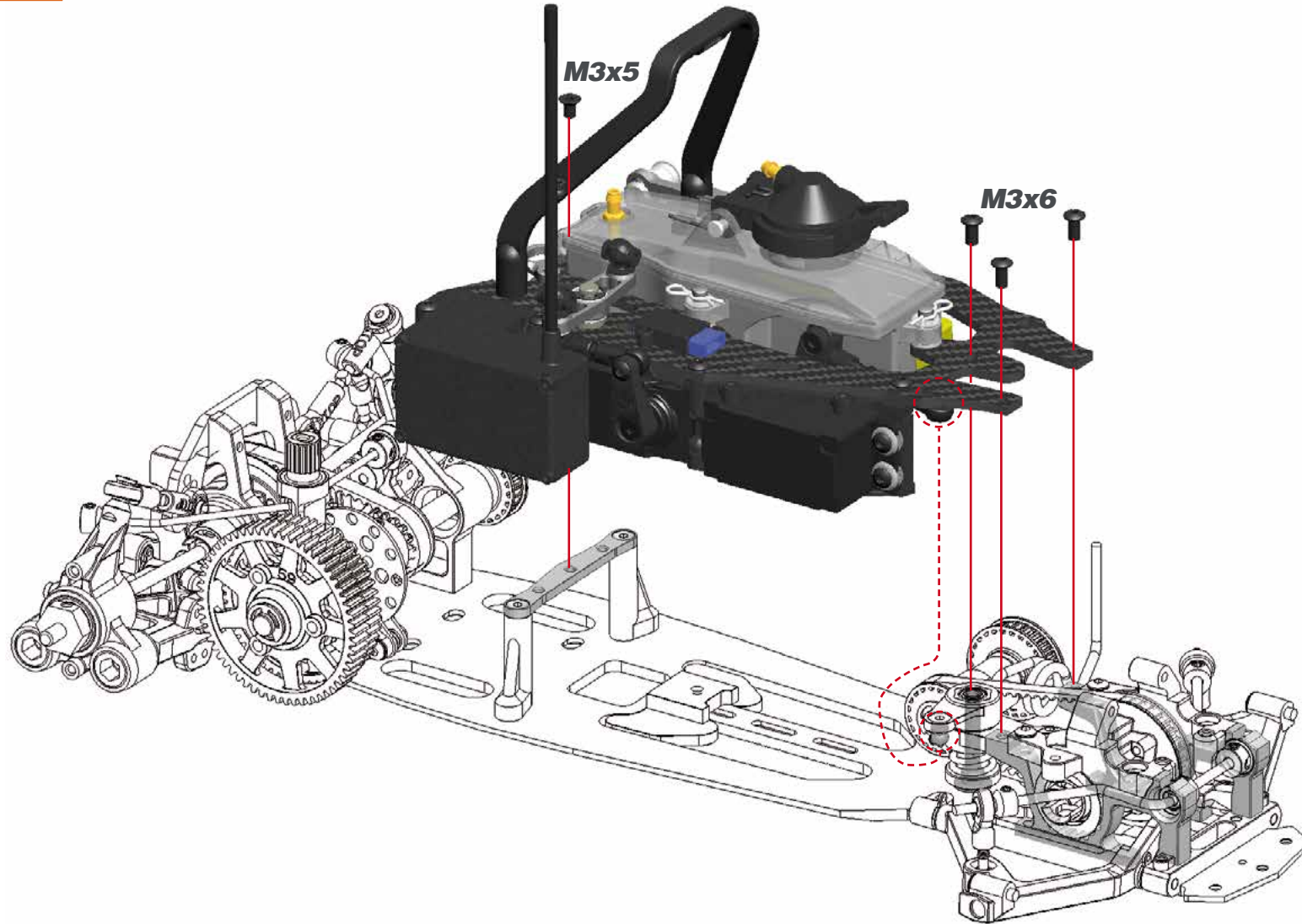



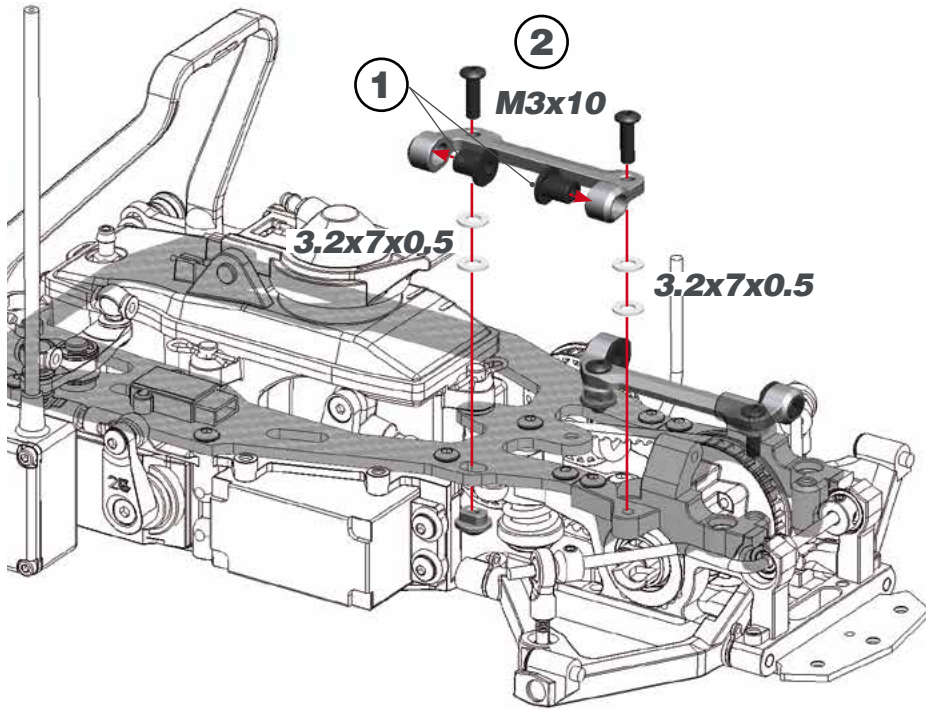

STEP 44



FRONT SUSPENSION INSERTS CHART

L=R

INSIDE		OUTSIDE	
RIGHT	LEFT	RIGHT	LEFT
			
			

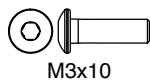

STEP 45

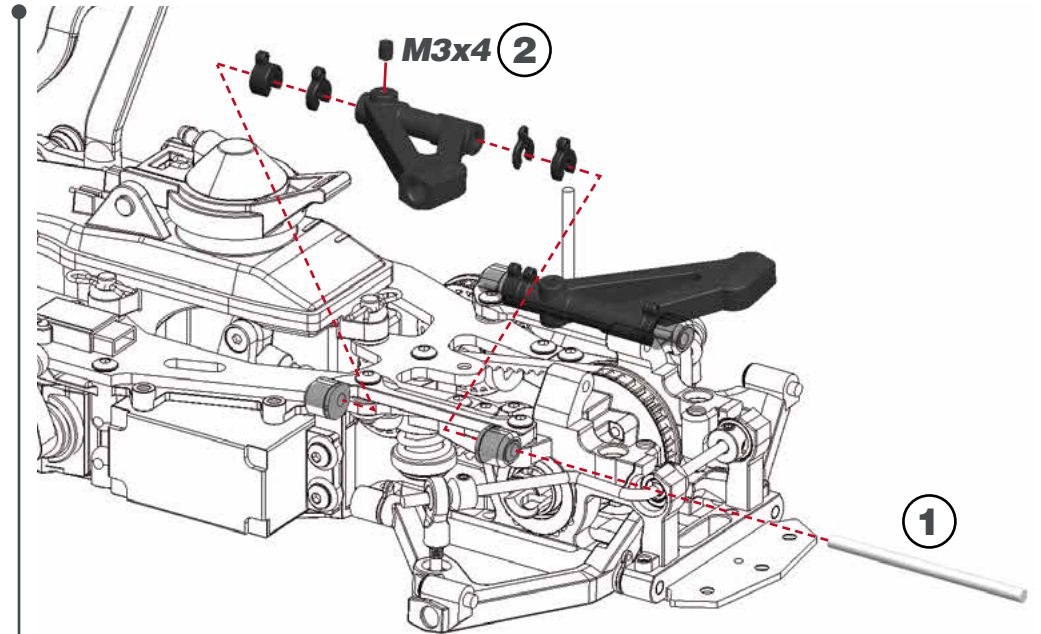

FRONT CASTOR DEFAULT SPACERS

L=R

DEF. SETUP

4mm 2mm 1mm 2mm



STEP 46 **BAG 18**

46.1

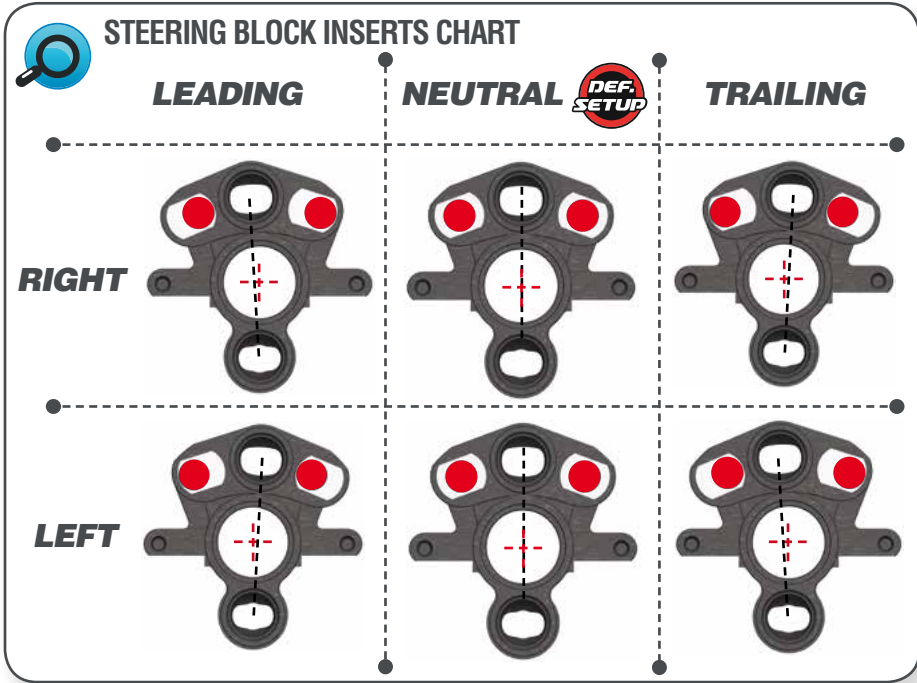
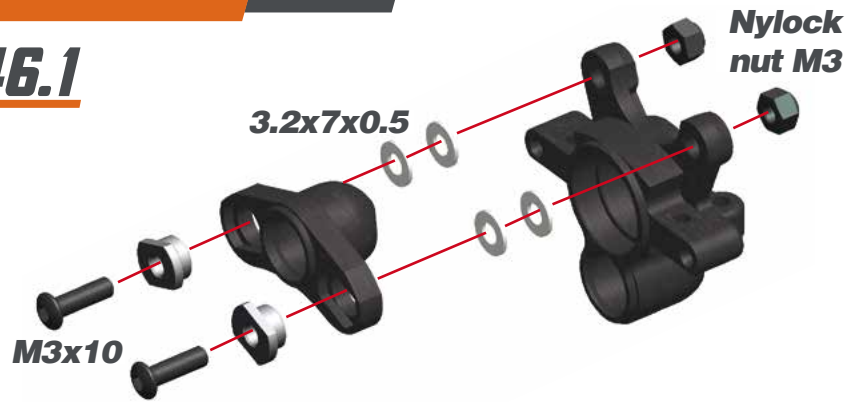

46.2

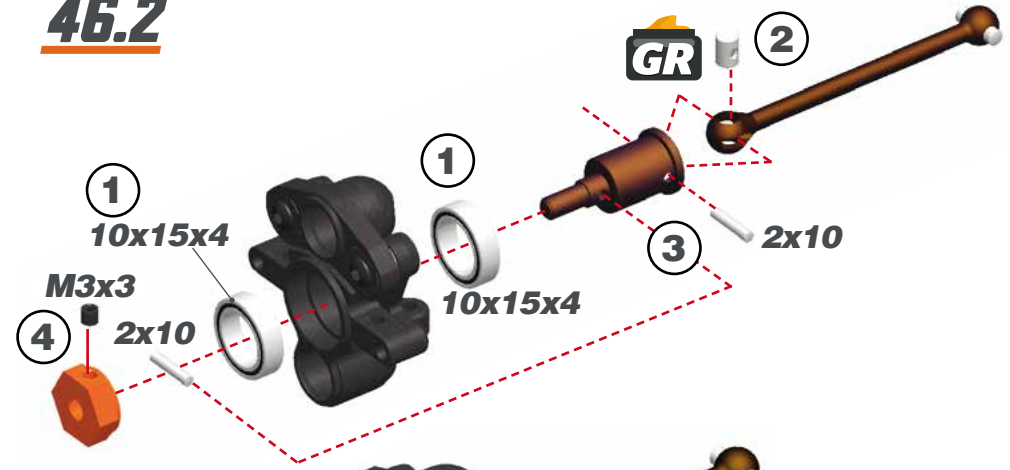

46.3

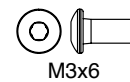
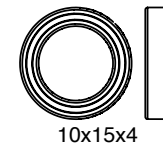
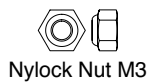
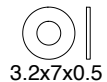
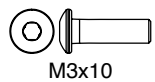
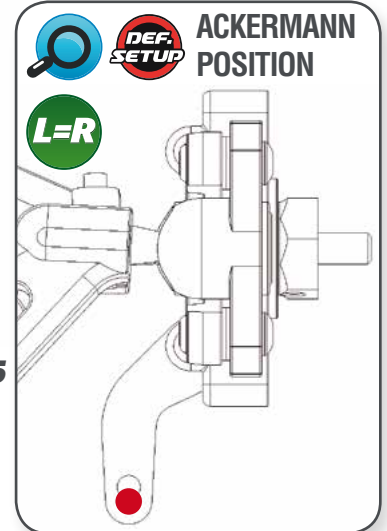
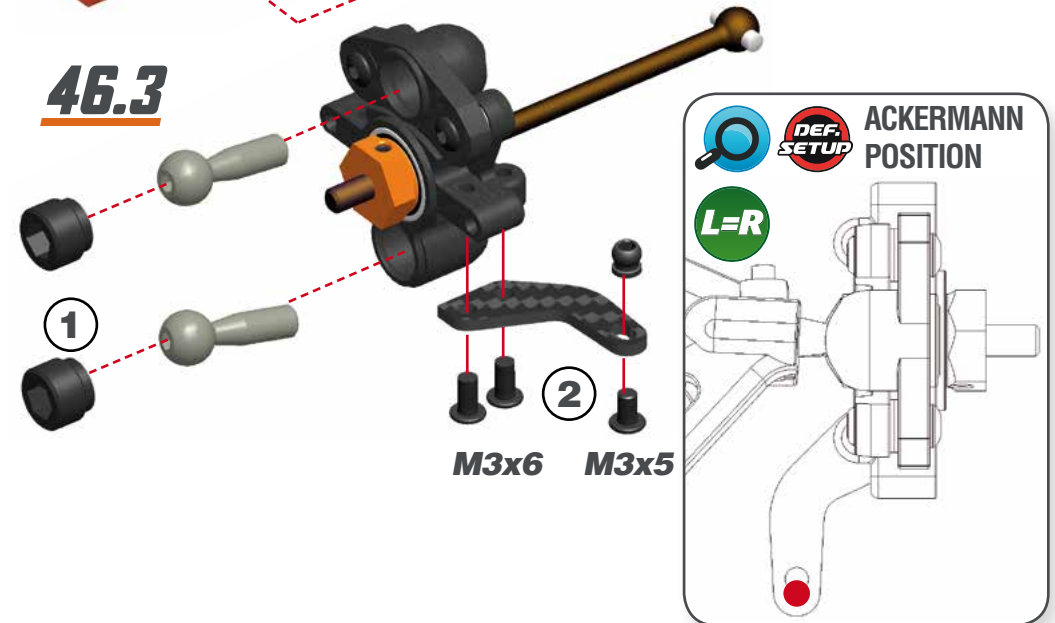

STEP 47

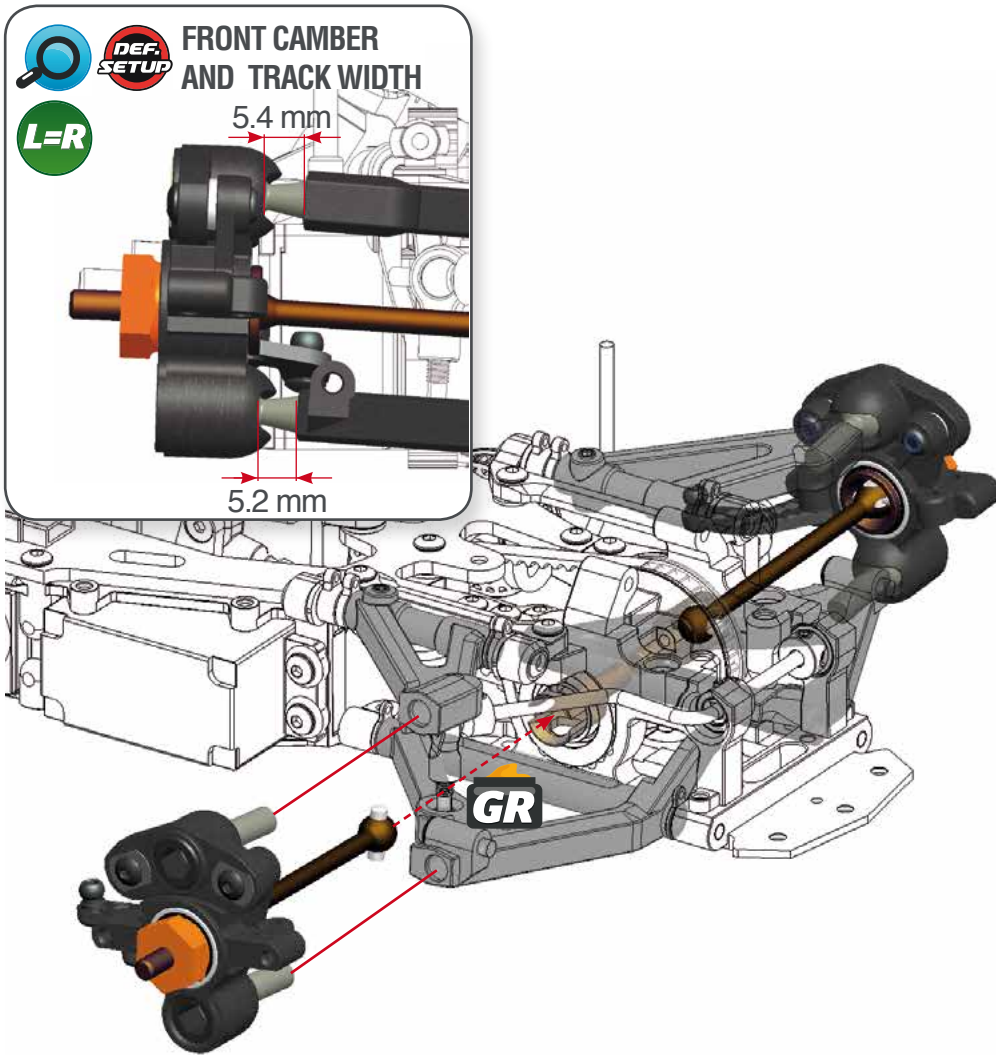

STEP 48

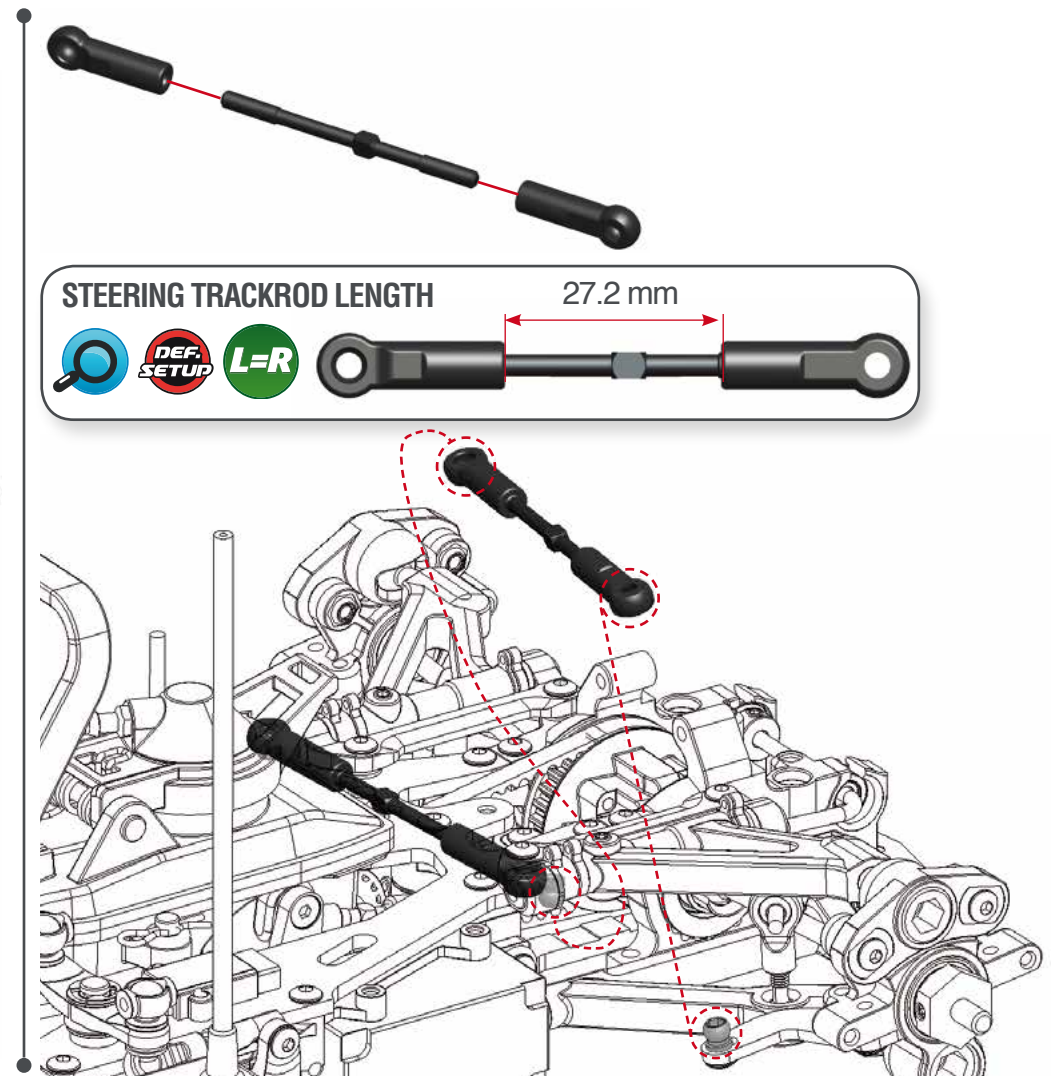

STEP 49 **BAG 11**

STEP 50

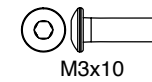
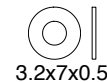
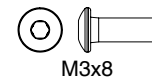
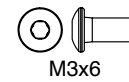
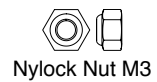
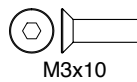
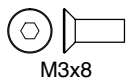
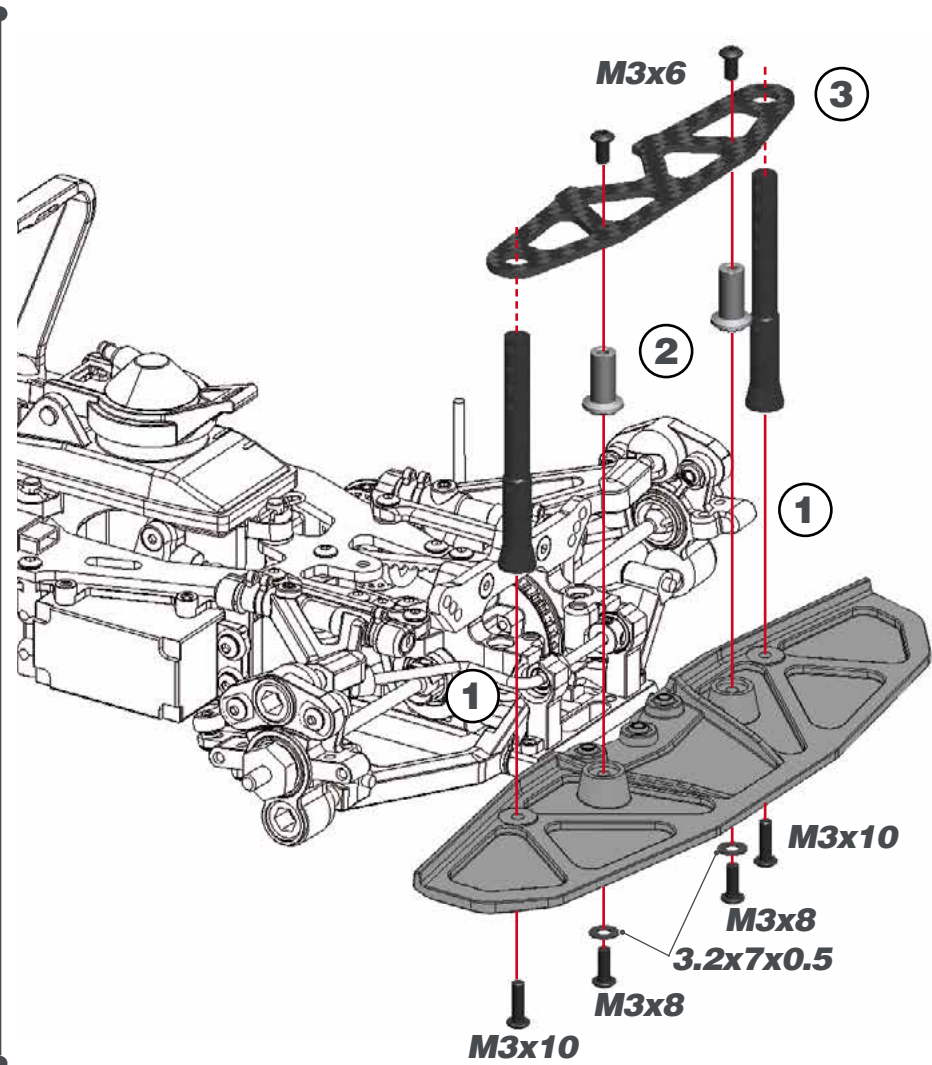
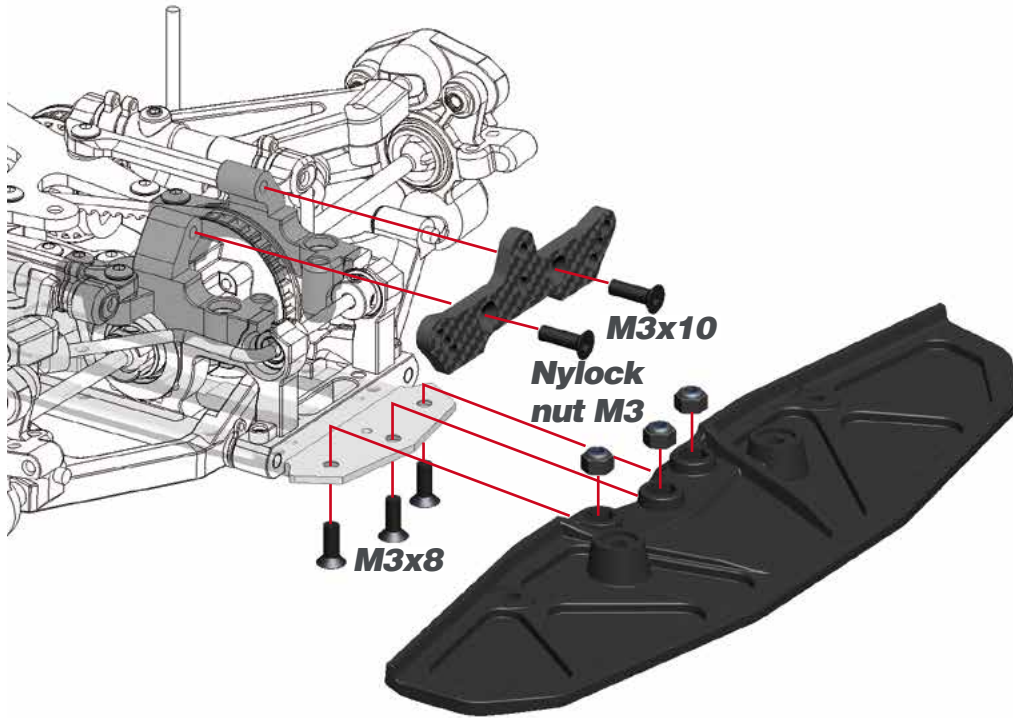

STEP 51

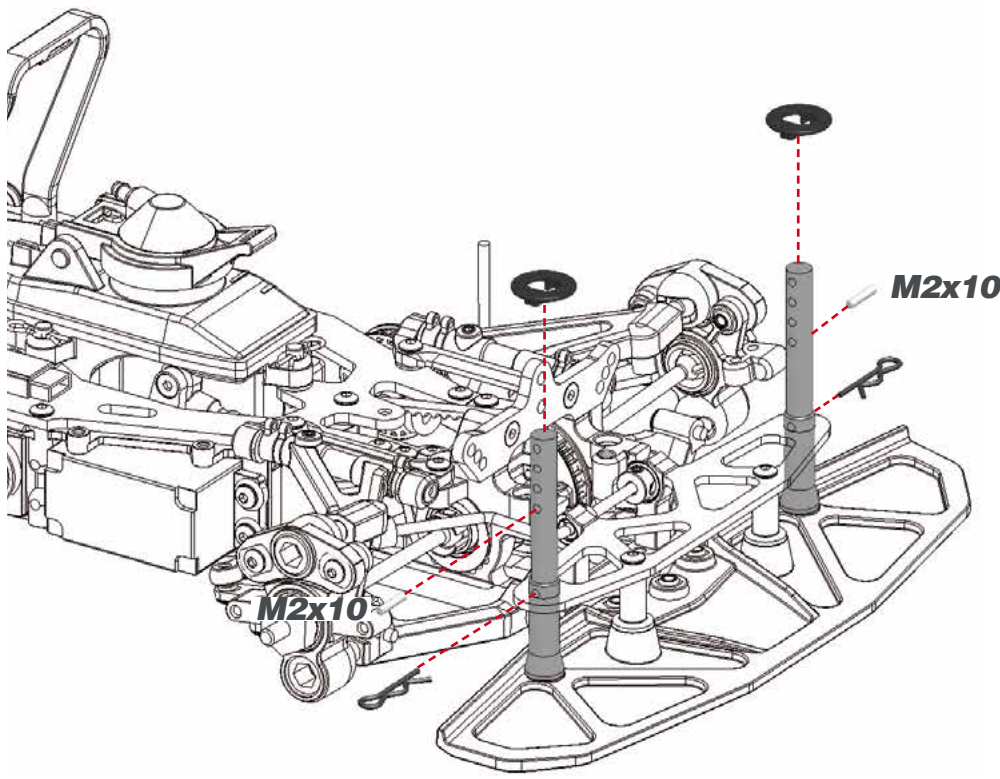





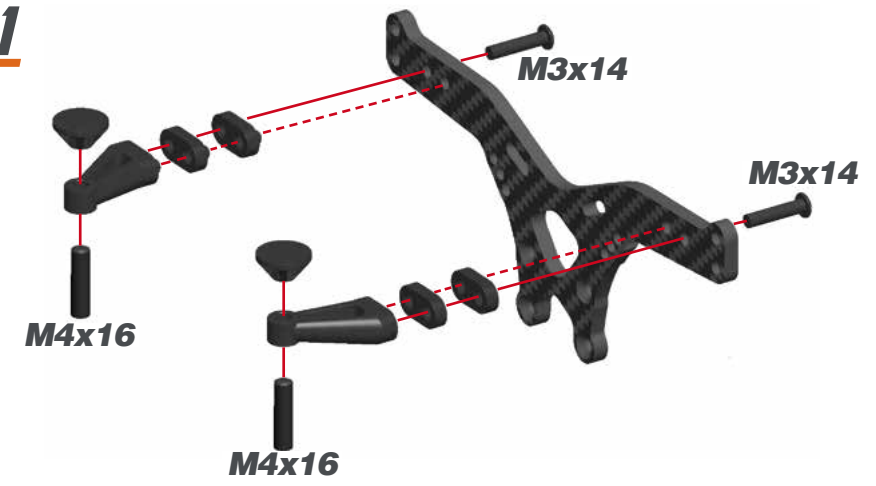

STEP 52

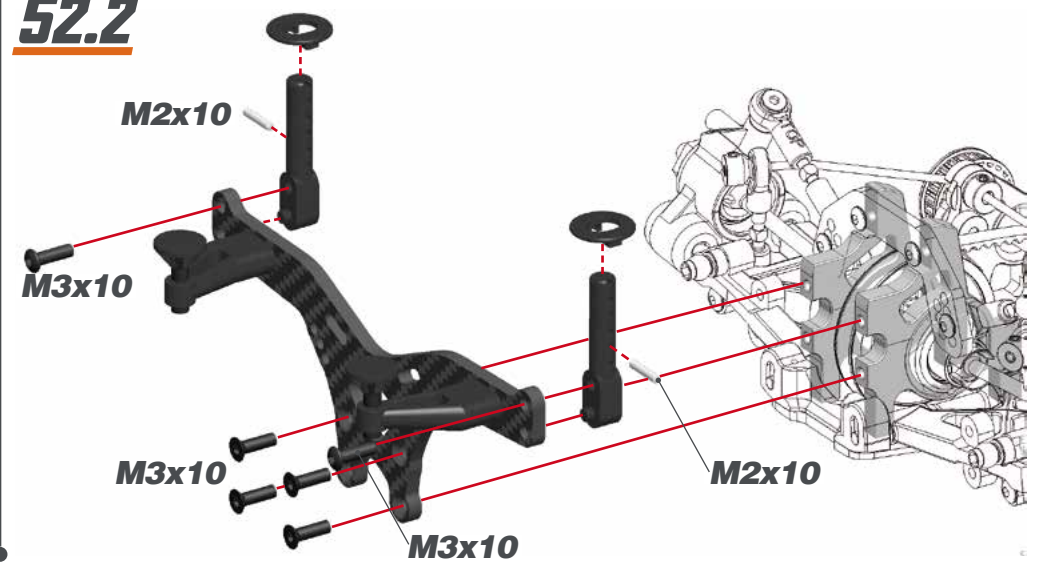
52.1



52.2

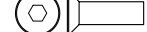

- 
 2x10
- 
 Body clip mid
- 
 M4x16
- 
 M3x14
- 
 M3x10
- 
 2x10
- 
 M3x10

STEP 53 **BAG 12**

53.1

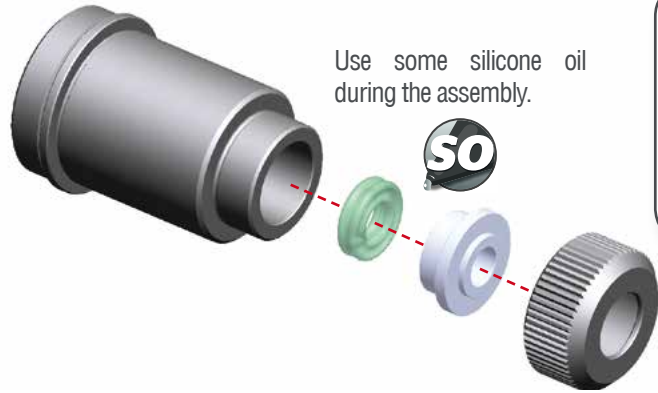

Use some silicone oil during the assembly.



53.2



1 Insert the o-ring inside the spring collar.



STEP 54

54.1

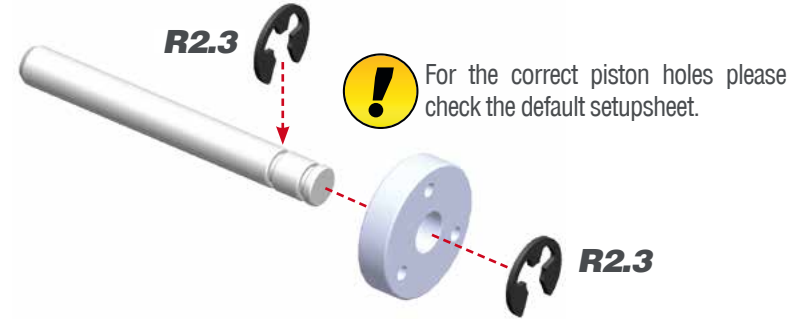

For the correct piston holes please check the default setupsheet.

54.2



Use some silicone oil during the assembly.



STEP 55

48.1

Push the shock top and the membrane into the shock cap.



48.2

1- Fill up with silicone oil fully using the silicone oil supplied in the kit. For the correct cst value please check the default setupsheet.

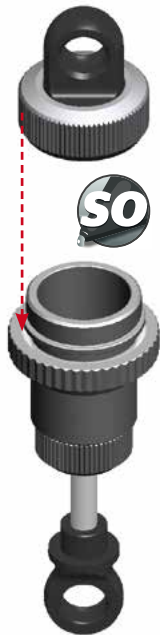

2- Extend the shockrod fully

3- Move the shockrod slowly up and down to let ALL air bubbles escape.

4- Close top only 3/4.

48.3

1-Bleed: push the shockrod all the way in slowly, to allow excessive oil to escape.

2- Close completely the shock cap.



SHOCKS LENGTH: Measure the shock length fully extended.

11.5 mm

STEP 56

Assemble the spring and spring-cup (align correctly) to complete the shock.

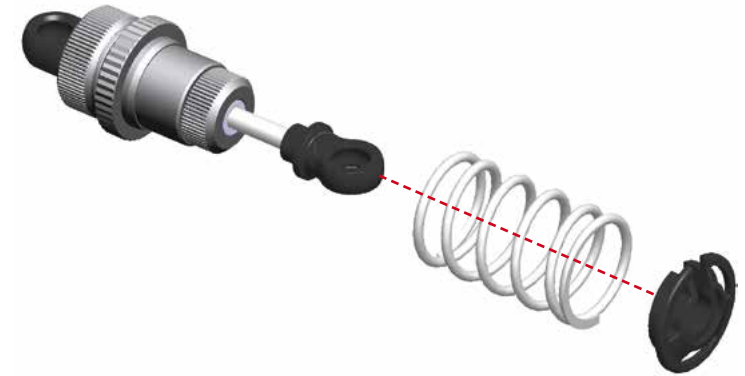

STEP 57

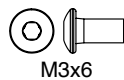
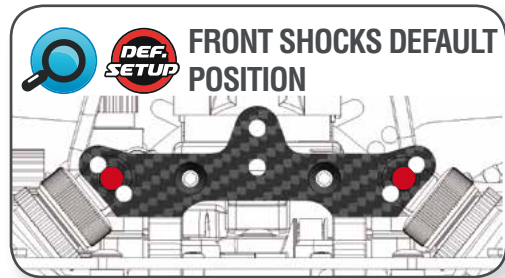
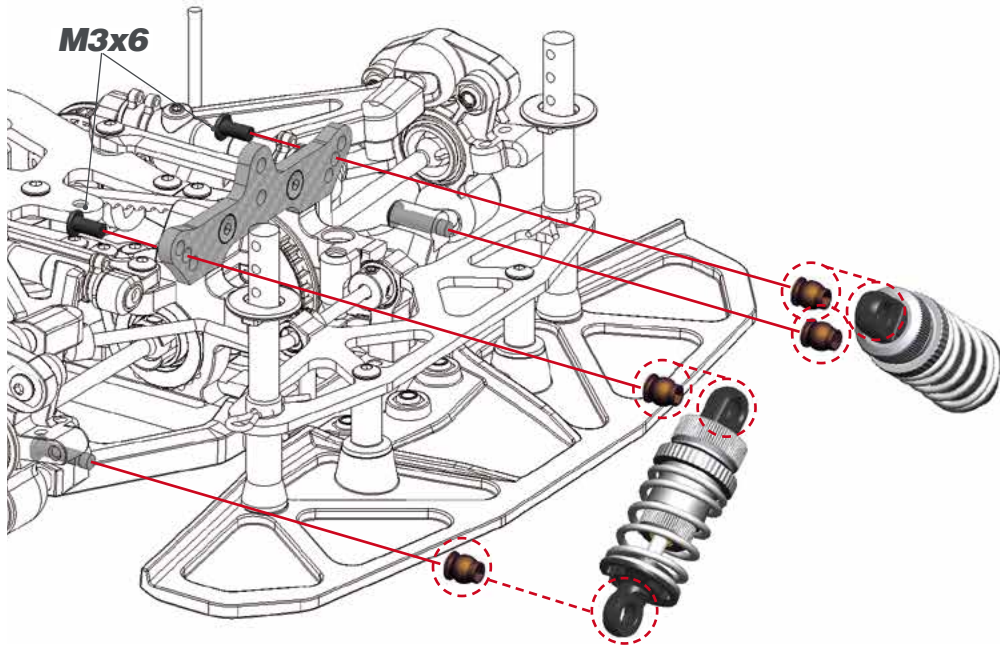

STEP 58

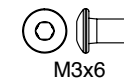
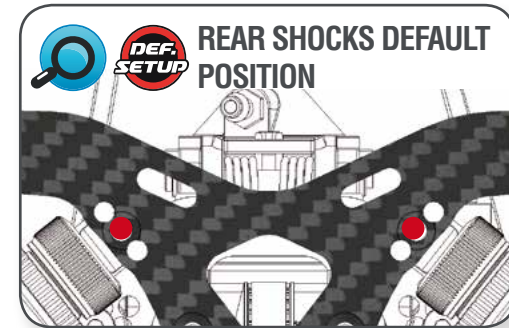
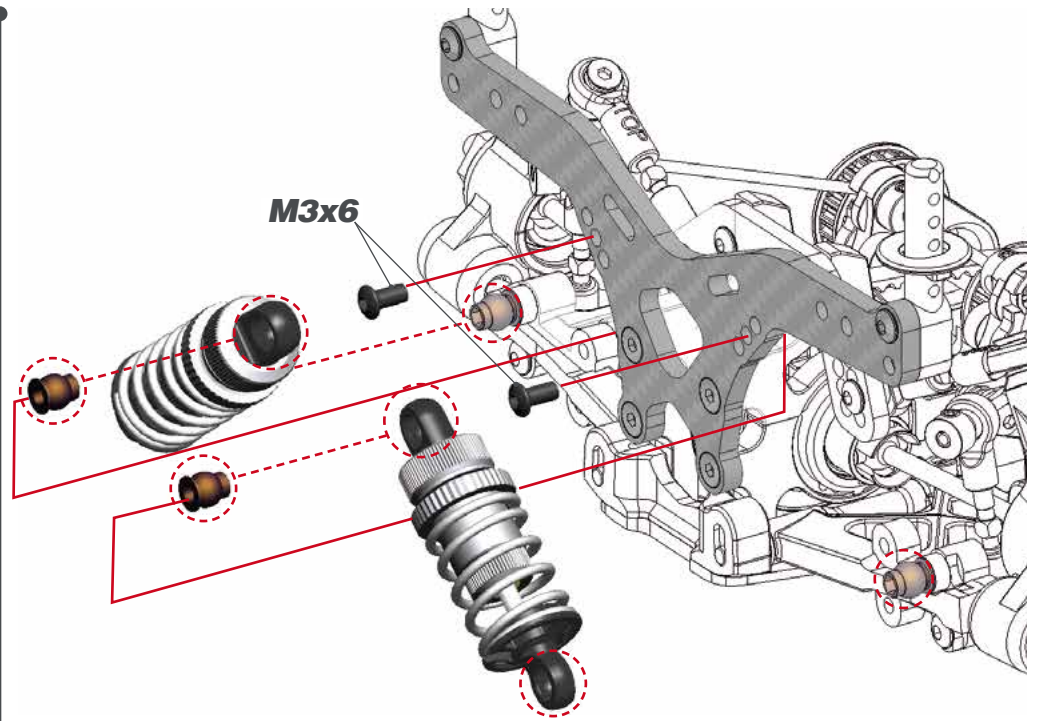

STEP 59 **BAG 13**

59.1

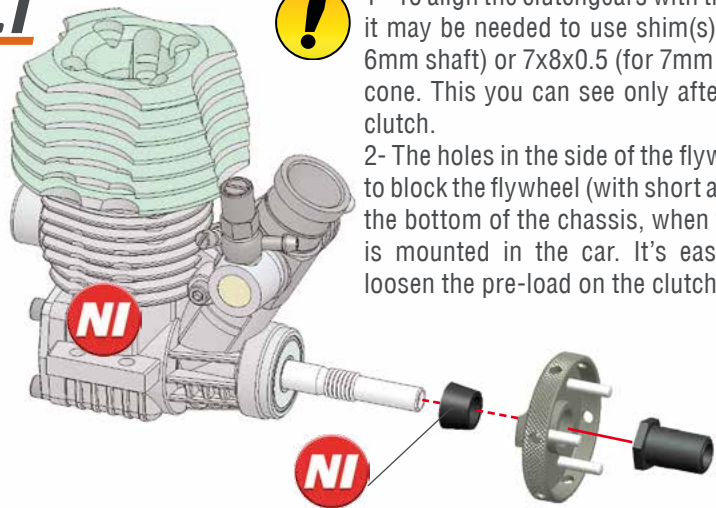

1- To align the clutchgears with the 2-speed gears, it may be needed to use shim(s) 6x8x0.5mm (for 6mm shaft) or 7x8x0.5 (for 7mm shaft) behind the cone. This you can see only after assembling the clutch.

2- The holes in the side of the flywheel can be used to block the flywheel (with short allen tool) through the bottom of the chassis, when the engine/clutch is mounted in the car. It's easier to tighten or loosen the pre-load on the clutch spring that way.

59.2

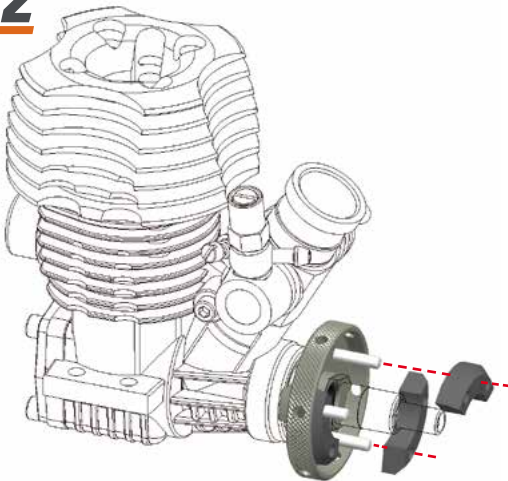

Note the orientation of the flyweights. Use the right hole for having a more aggressive clutch

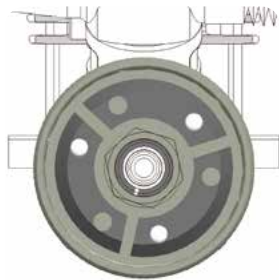

STEP 60

60.1

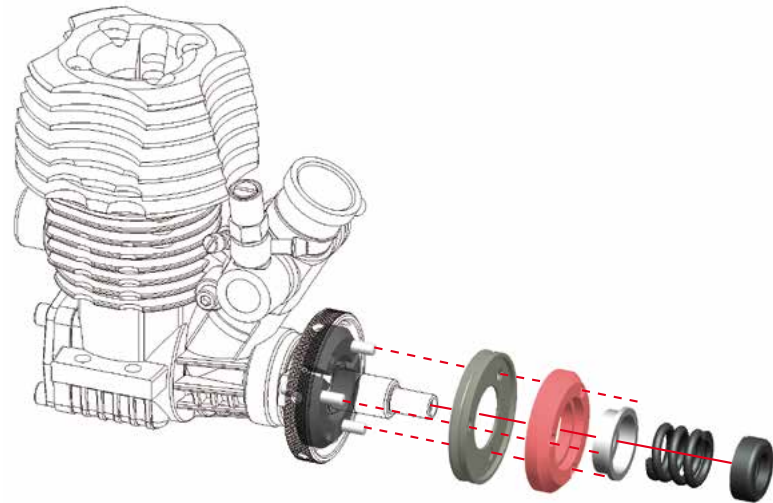

60.2



For adjusting the default clutch spring tension:

- 1- Screw in the adjusting nut all the way.
- 2- Unscrew it one and a half turns.
- 3- Fine tune the setup of your clutch on the track according to your driving style, track and weather conditions.

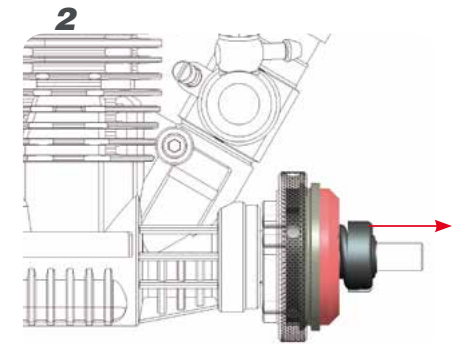
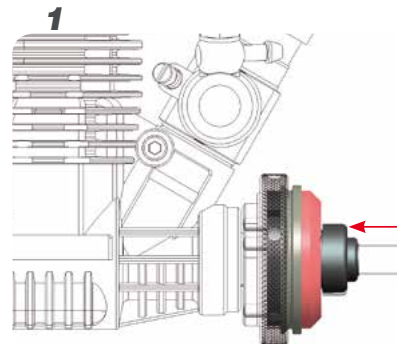

STEP 61

61.1

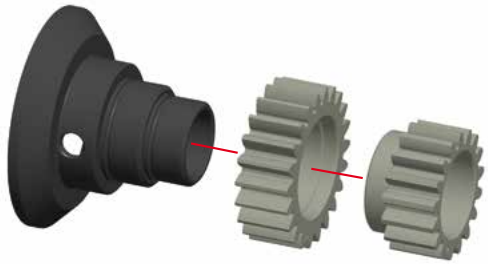

! Note the orientaion of the gears

2ND 1ST

61.2

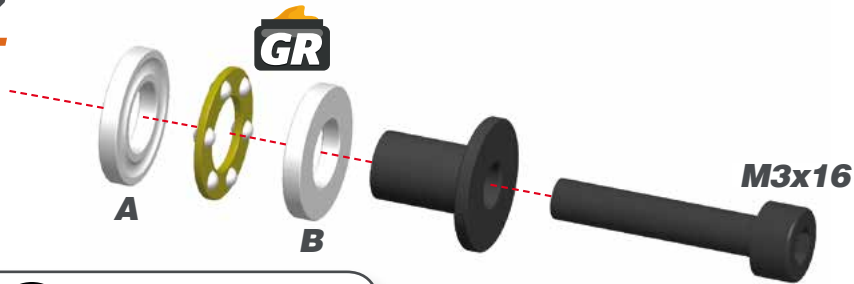

! IMPORTANT! Install thrust bearing plates as shown.

A 5.2 mm **B** 5.0 mm

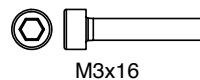

STEP 62

62.1 SETTING THE CLUTCH GAP

0.5 - 0.6mm

! Use 5x8x0.1 and 5x8x0.3 shims to achieve desired gap

62.2 SETTING THE CLUTCH END PLAY

5x10x4
5x8x2.5

! Place 5x8x0.1 and/or 5x8x0.3 shims to achive a small amount of end play.

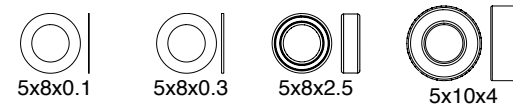

STEP 63 **BAG 14**

63.1

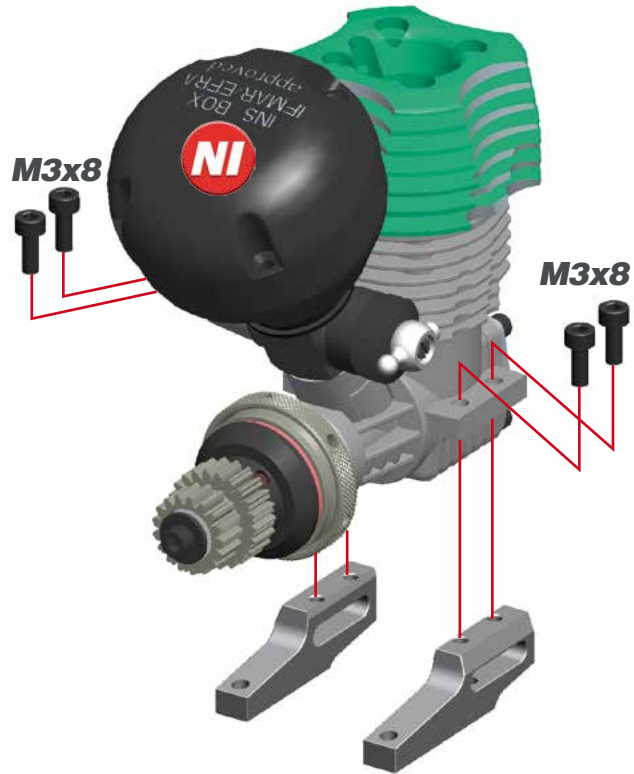

63.2

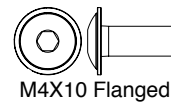
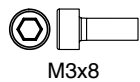
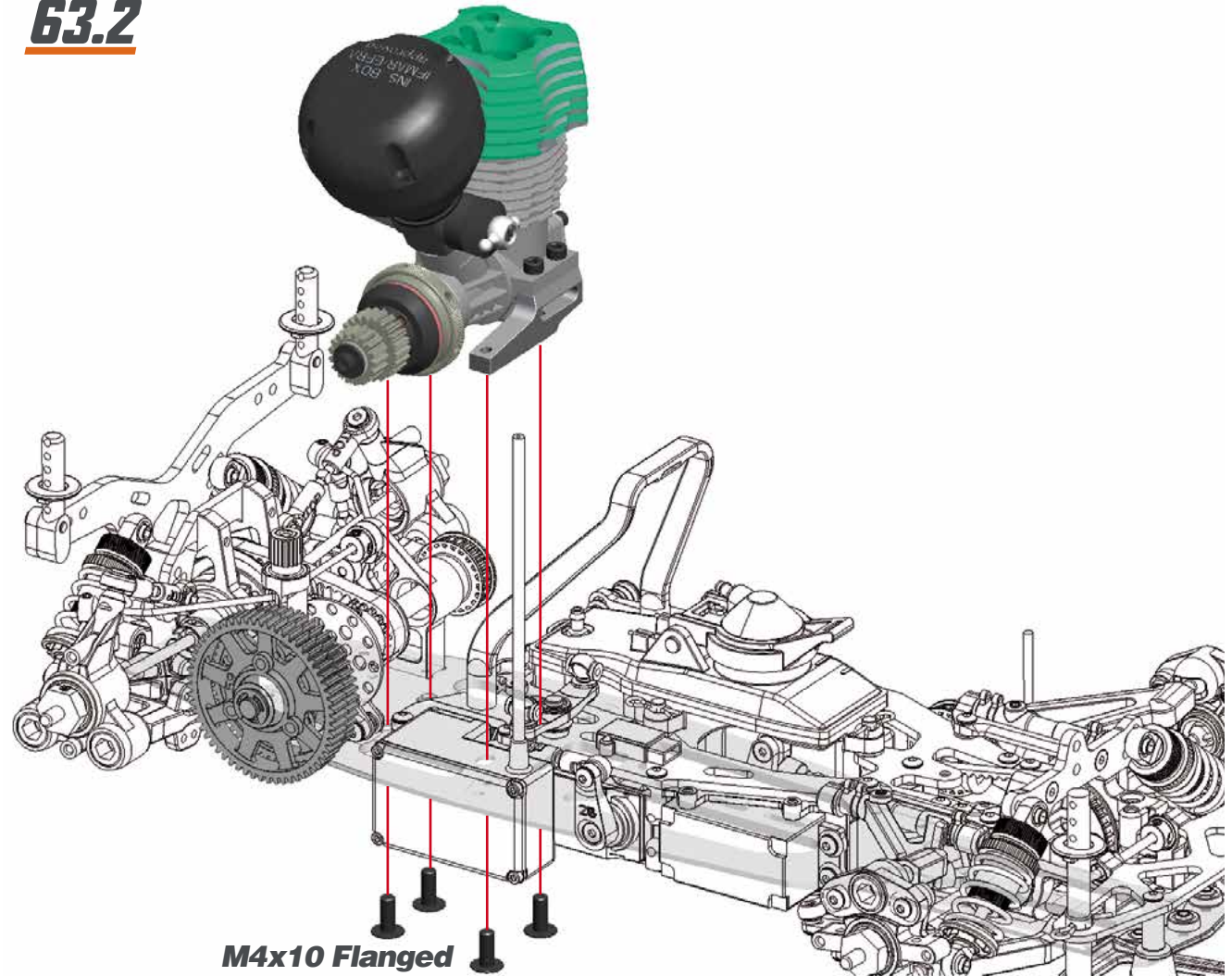

STEP 64

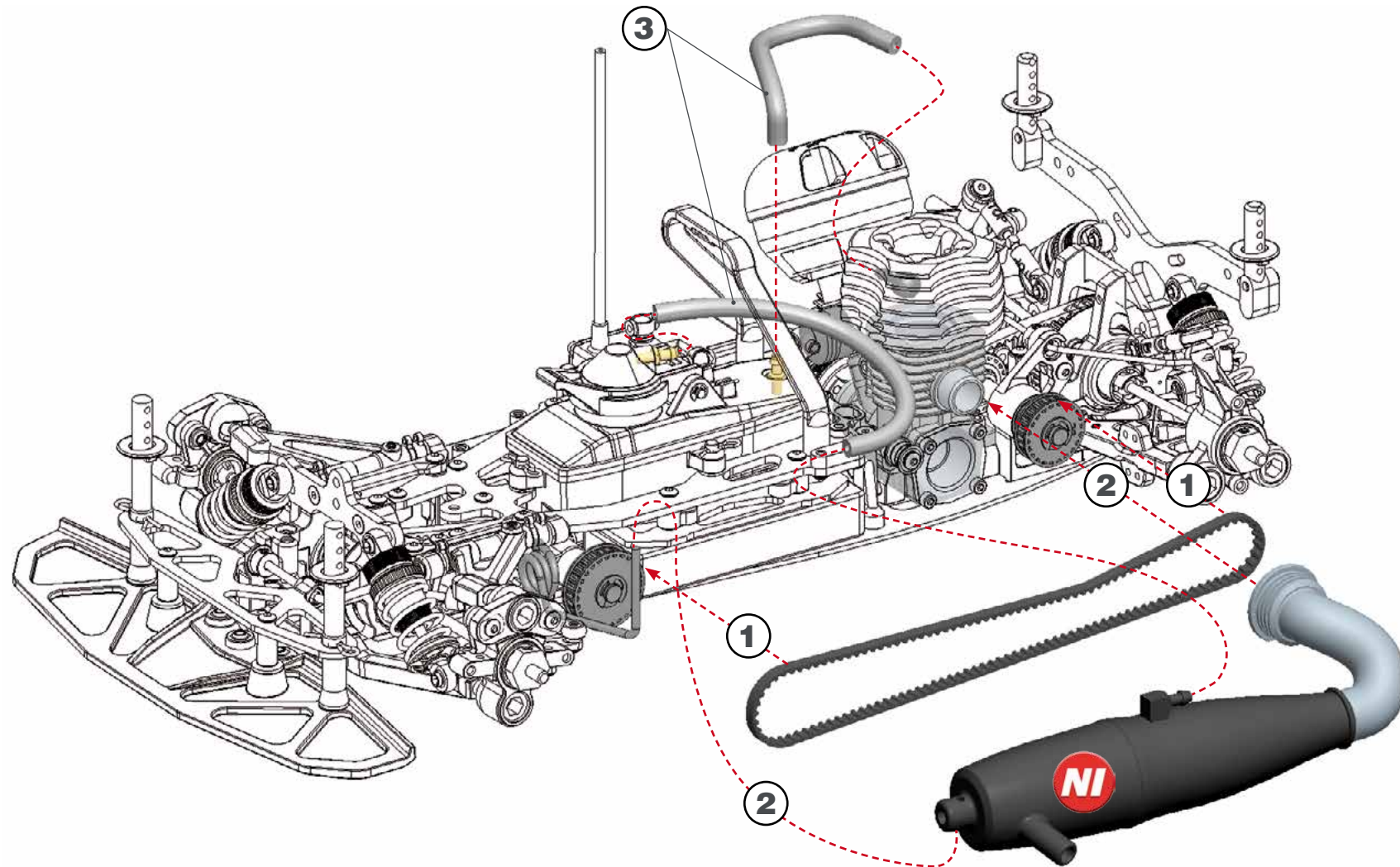

STEP 65

65.1

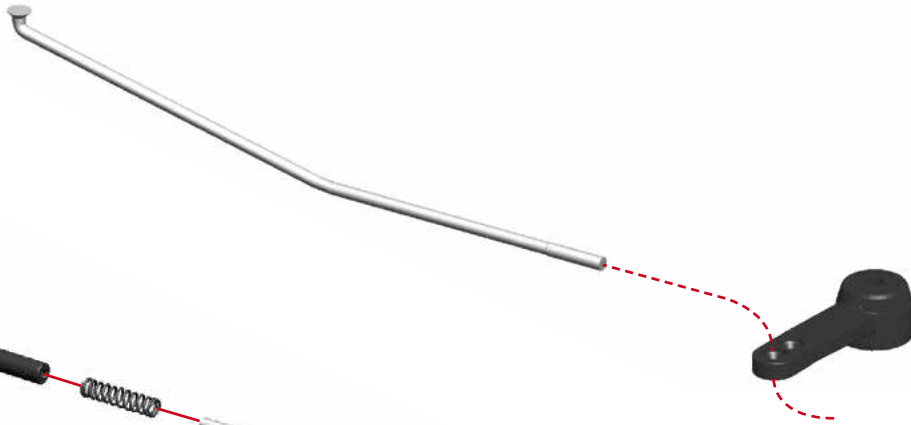

65.2

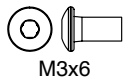
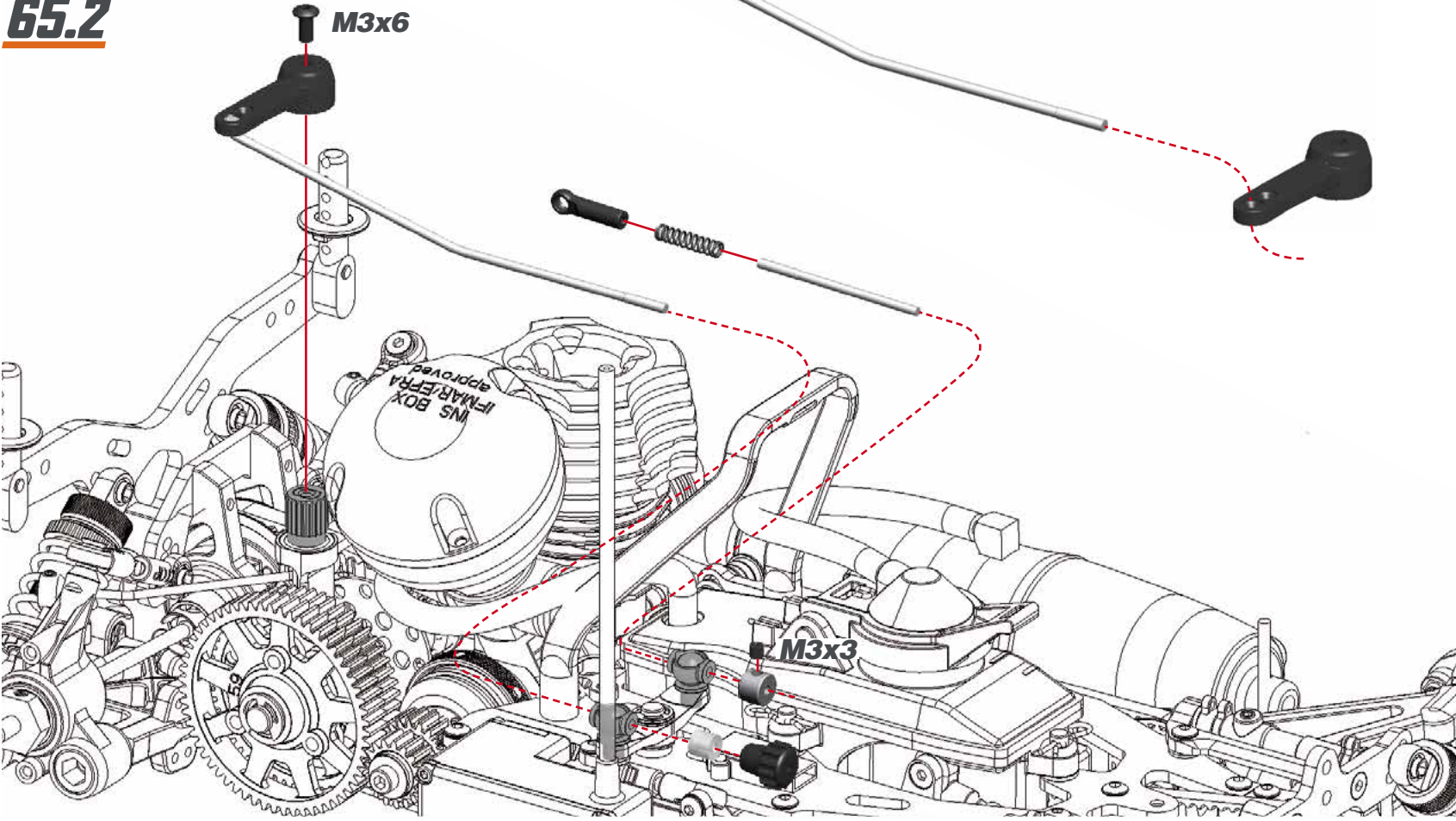

STEP 66

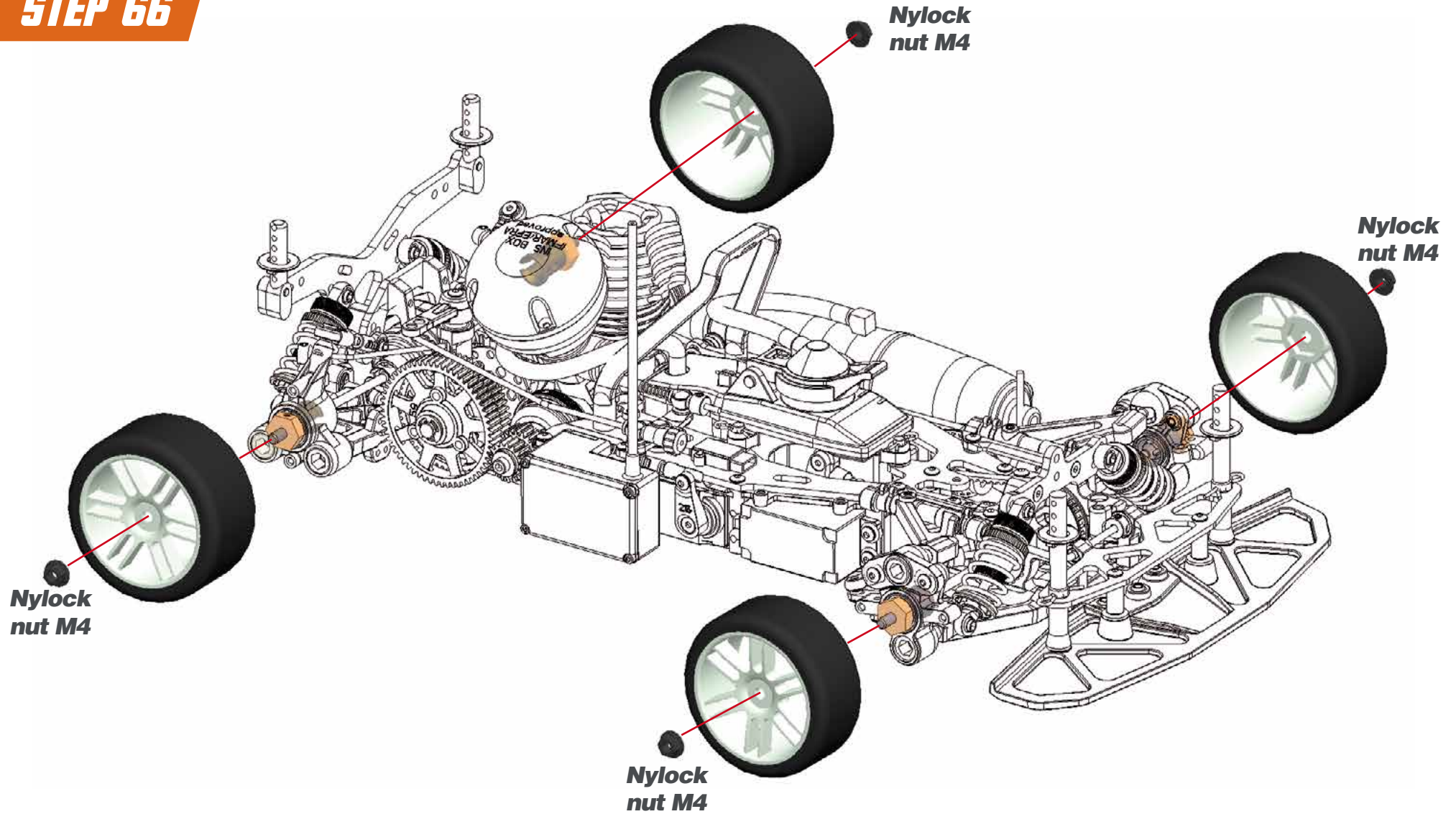

INDEX

<i>DIFFERENTIAL AND GEARBOX EXPLODED VIEW</i>	43
<i>SHOCKS EXPLODED VIEW</i>	44
<i>REAR EXPLODED VIEW</i>	45
<i>RADIO EXPLODED VIEW</i>	46
<i>FRONT I EXPLODED VIEW</i>	47
<i>FRONT II EXPLODED VIEW</i>	48
<i>SHOCKS MOUNTING EXPLODED VIEW</i>	49
<i>CLUTCH EXPLODED VIEW</i>	50
<i>FINAL EXPLODED VIEW</i>	51
<i>TEAM SERPENT NETWORK</i>	52

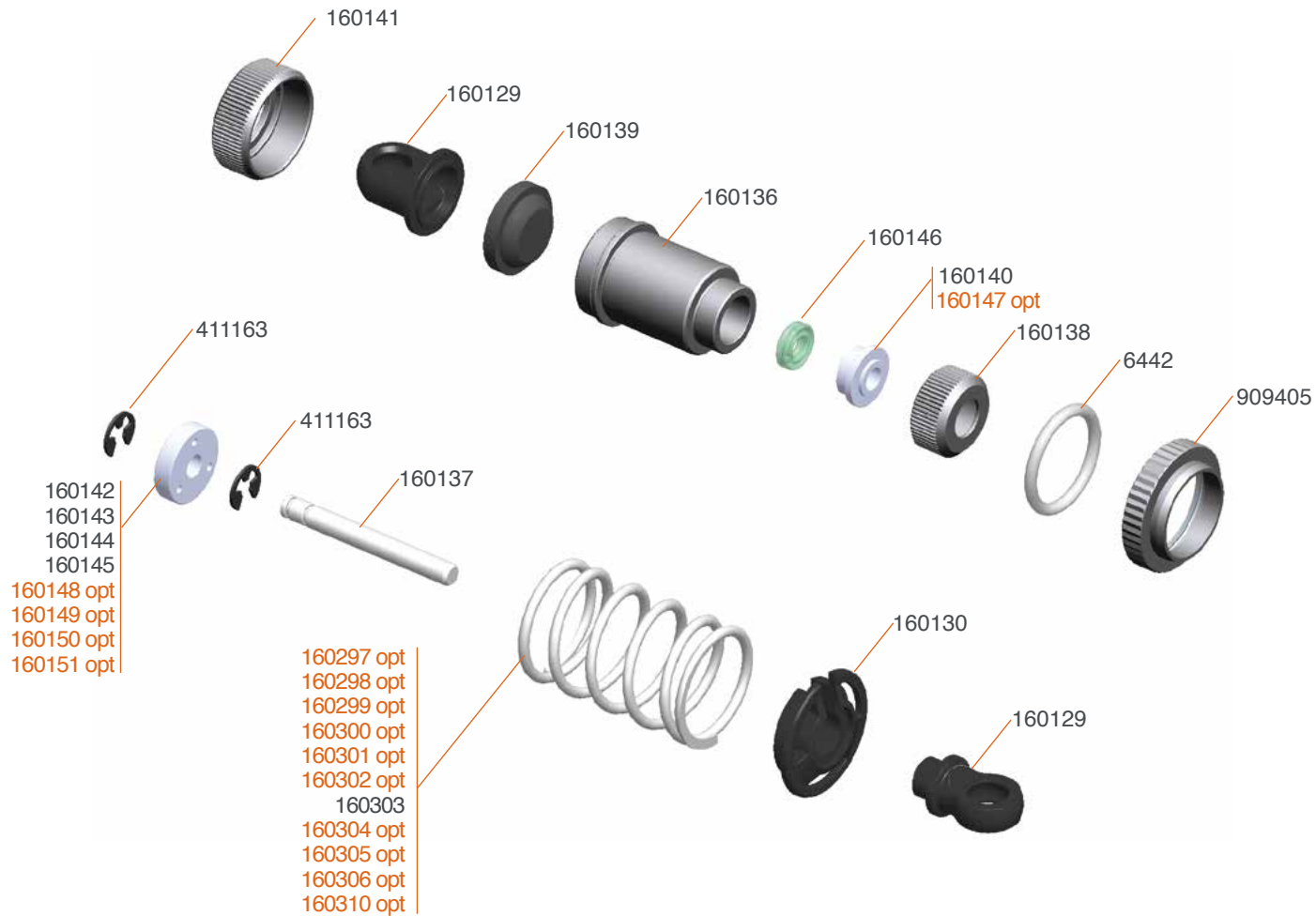

- 160148 Shock onroad big bore piston 1 hole LF (2)
- 160149 Shock onroad big bore piston 2 hole LF (2)
- 160150 Shock onroad big bore piston 3 hole LF (2)
- 160151 Shock onroad big bore piston 4 hole LF (2)
- 160297 Spring grey TC

- 160298 Spring black TC
- 160299 Spring green TC
- 160300 Spring white
- 160301 Spring yellow
- 160302 Spring orange

- 160304 Spring Pink
- 160305 Spring blue
- 160306 Spring purple
- 160310 Spring-set L23 (5x2)
- 160147 Shock onroad big bore bushing LF (4)



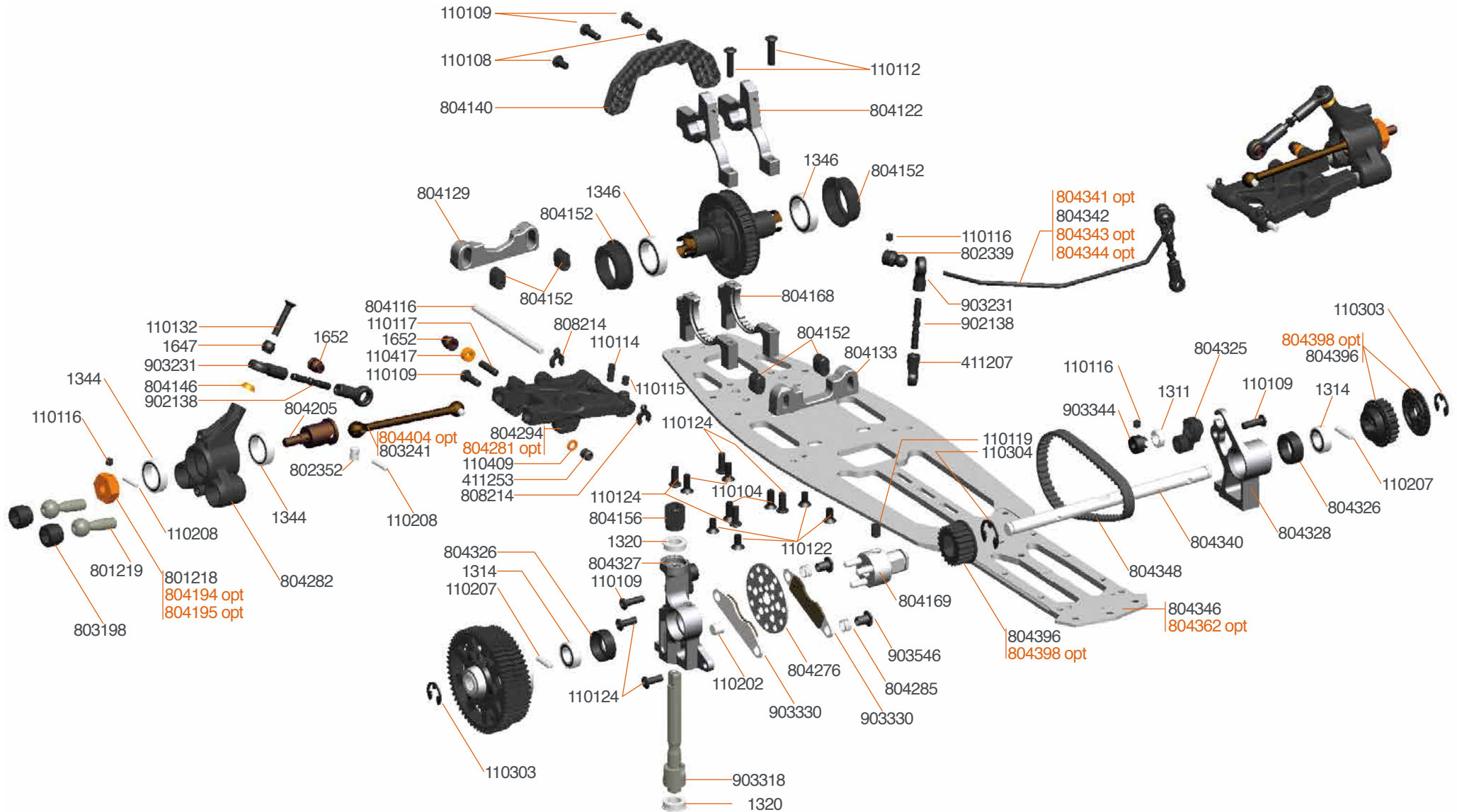

- 803240 CVD-set Pro (2)
- 804194 Wheel hexagon +1mm (4)
- 804195 Wheel hexagon -1mm (4)
- 804281 Wishbone 747 RR LW medium (2)

- 804341 Antiroll bar 1.6 RR 748
- 804343 Antiroll bar 2.0 RR 748
- 804344 Antiroll bar 2.2 RR 748
- 804362 Chassis alu hard coated 748

- 804398 Pulley set low friction (6) 748 V2
- 804401 Wheel-axle set CVD alu (2)
- 804402 Wheelaxle CVD alu (2)
- 804403 Wheelaxle CVD -1mm alu (2)

- 804404 Driveshaft CVD alu (2)

FRONT / EXPLODED VIEW

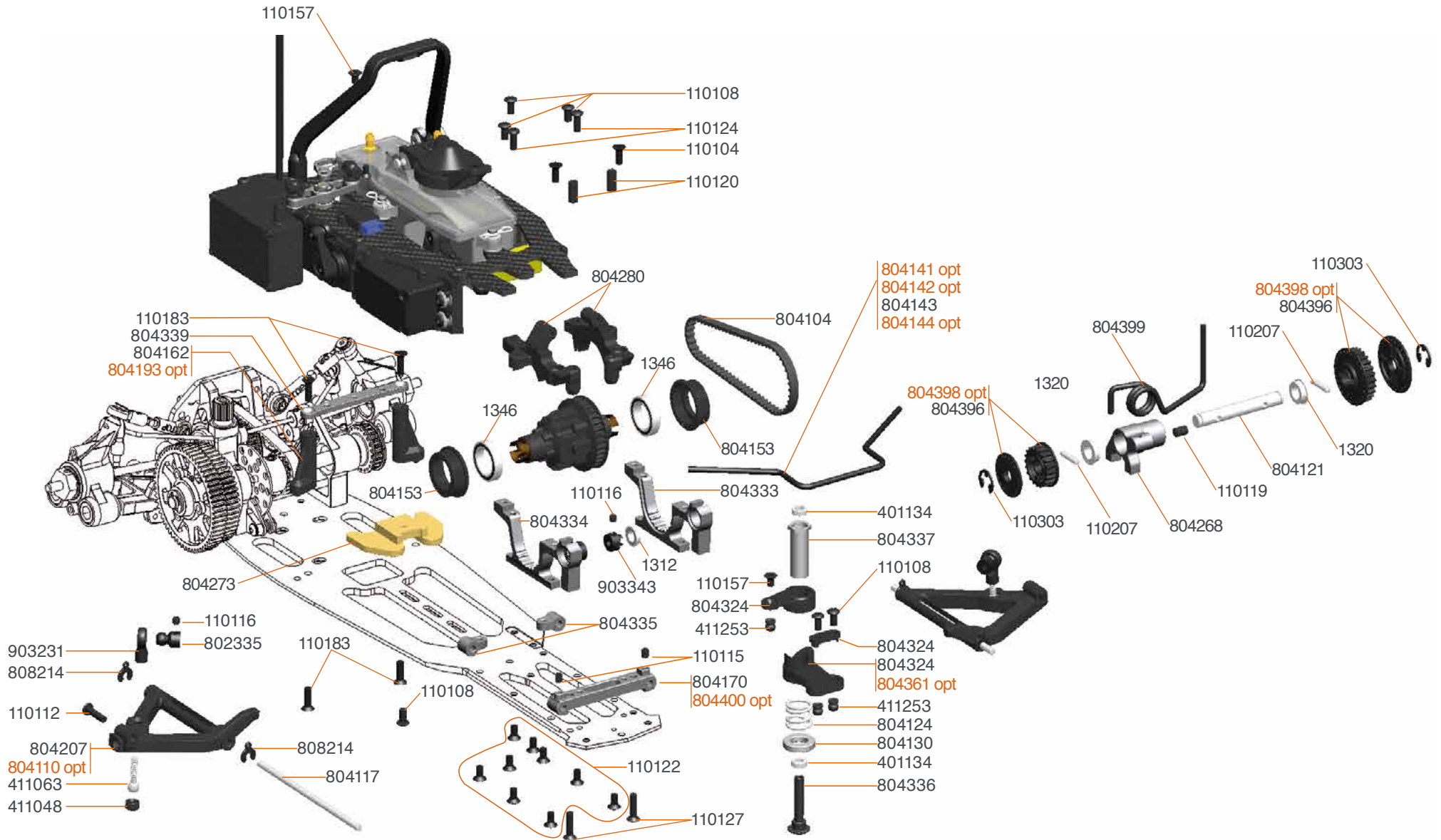

804110 Wishbone front lw L+R (M)
804141 Anti-rollbar FR 1.8mm
804142 Anti-rollbar FR 2.2mm

804144 Anti-rollbar FR 2.8mm
804193 Radioplate support alu
804361 Servosaver bottom alu

804374 Solid axle set front alu
804375 Solid axle front alu
804376 Solid axle outdrive (2)

804398 Pulley set low friction (6) 748 V2
804400 Suspension bracket FR brass

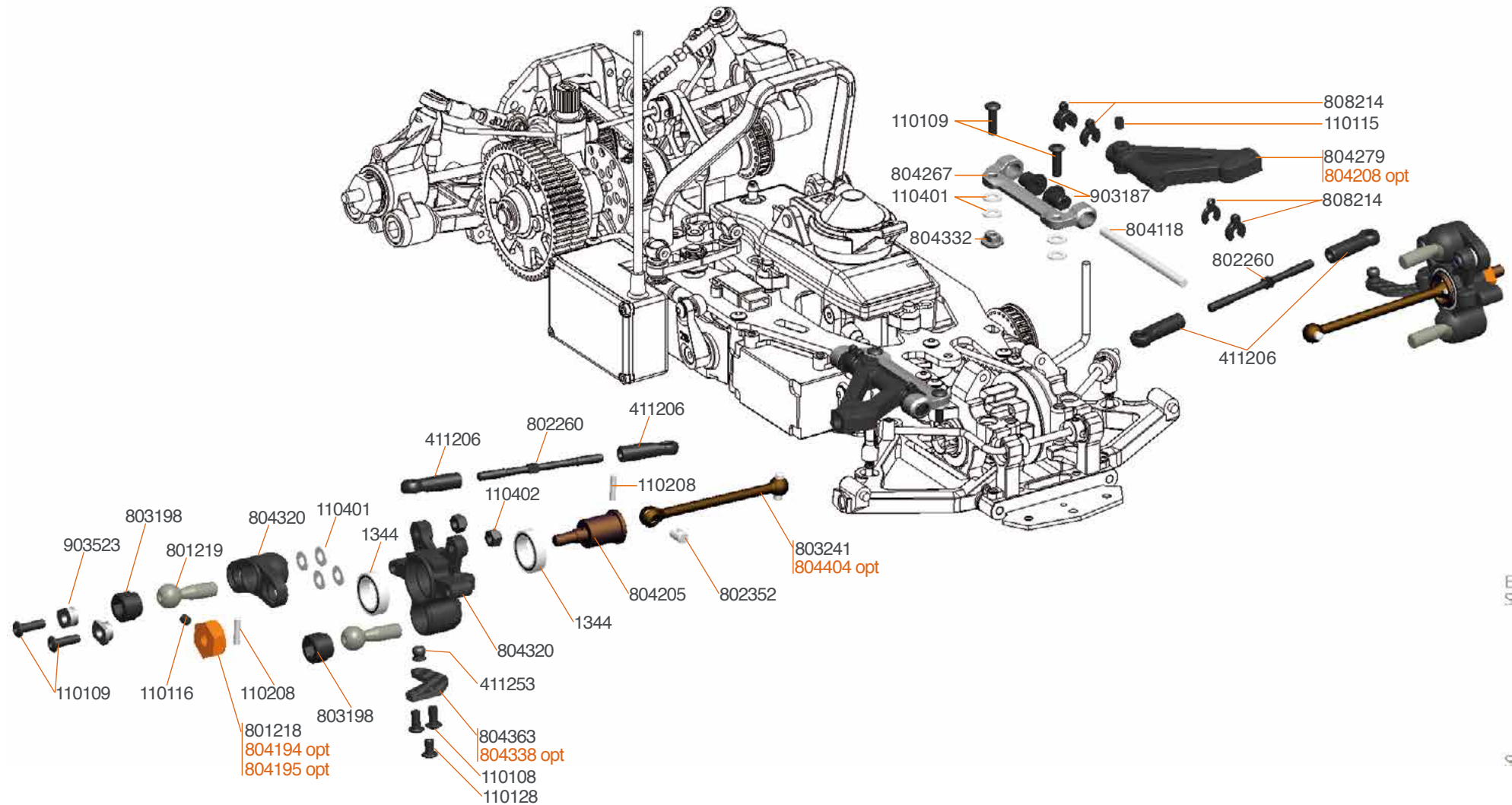

804194 Wheel hexagon +1mm (4)
 804195 Wheel hexagon -1mm (4)
 804208 Wishbone front up L+R Hard

804240 CVD-set Pro (2)
 804363 Steeringblock lever carbon 748 (2)
 804401 Wheel-axle set CVD alu (2)

804402 Wheelaxle CVD alu (2)
 804403 Wheelaxle CVD -1mm alu (2)
 804404 Driveshaft CVD alu (2)

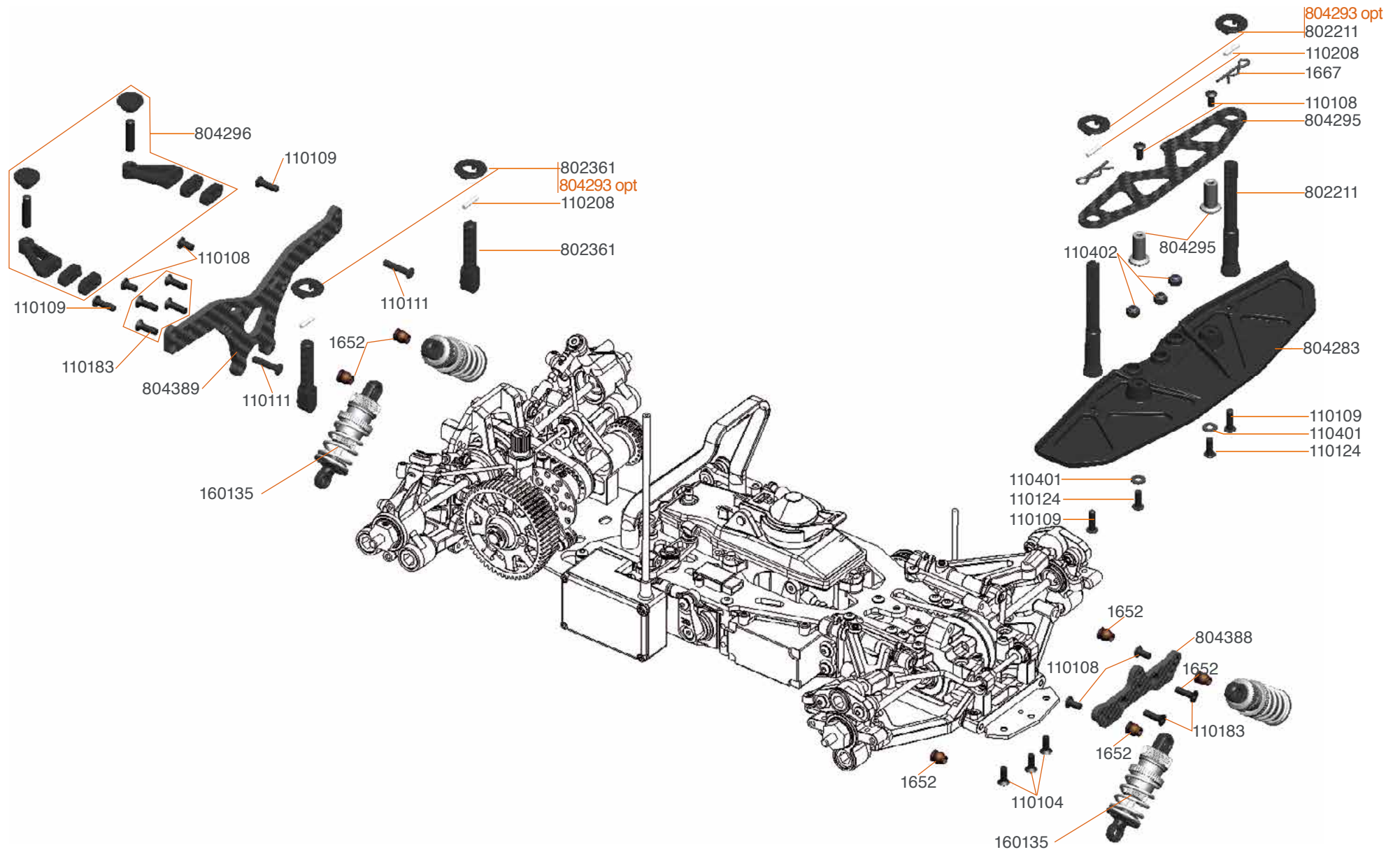

804293 Body support washers med + high (5+5)



Centax True Motion clutch 1/10 #804250

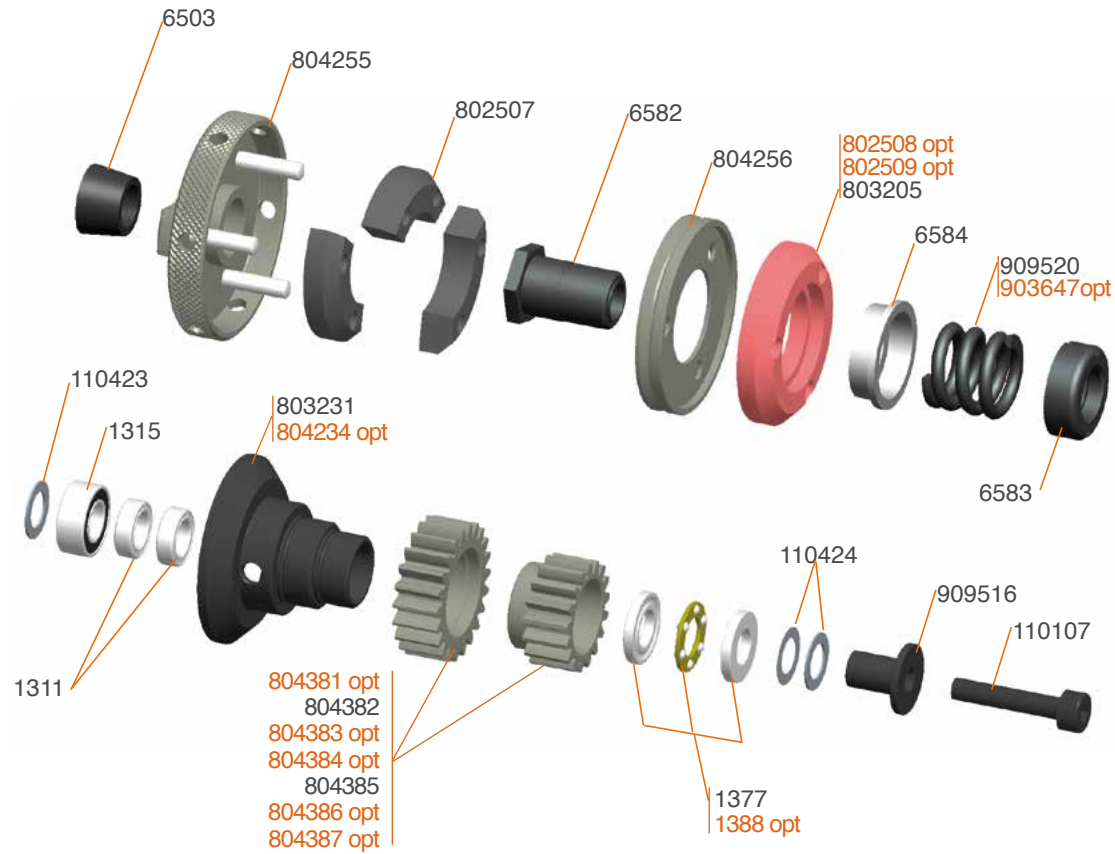

1388 Thrust bearing 5x10 Ceramic
 802508 Centax - 3 clutch shoe XP
 802509 Centax-3 clutch shoe yellow
 804234 Centax-3 clutchbell alu coated

804381 Centax-3 gear-pinion alu 15t wc V2
 804383 Centax-3 gear-pinion alu 17t wc V2
 804384 Centax-3 gear-pinion alu 20t wc V2
 804386 Centax-3 gear-pinion alu 22t wc V2

804387 Centax-3 gear-pinion alu set wc (6) V2
 903647 Centax spring x-hard

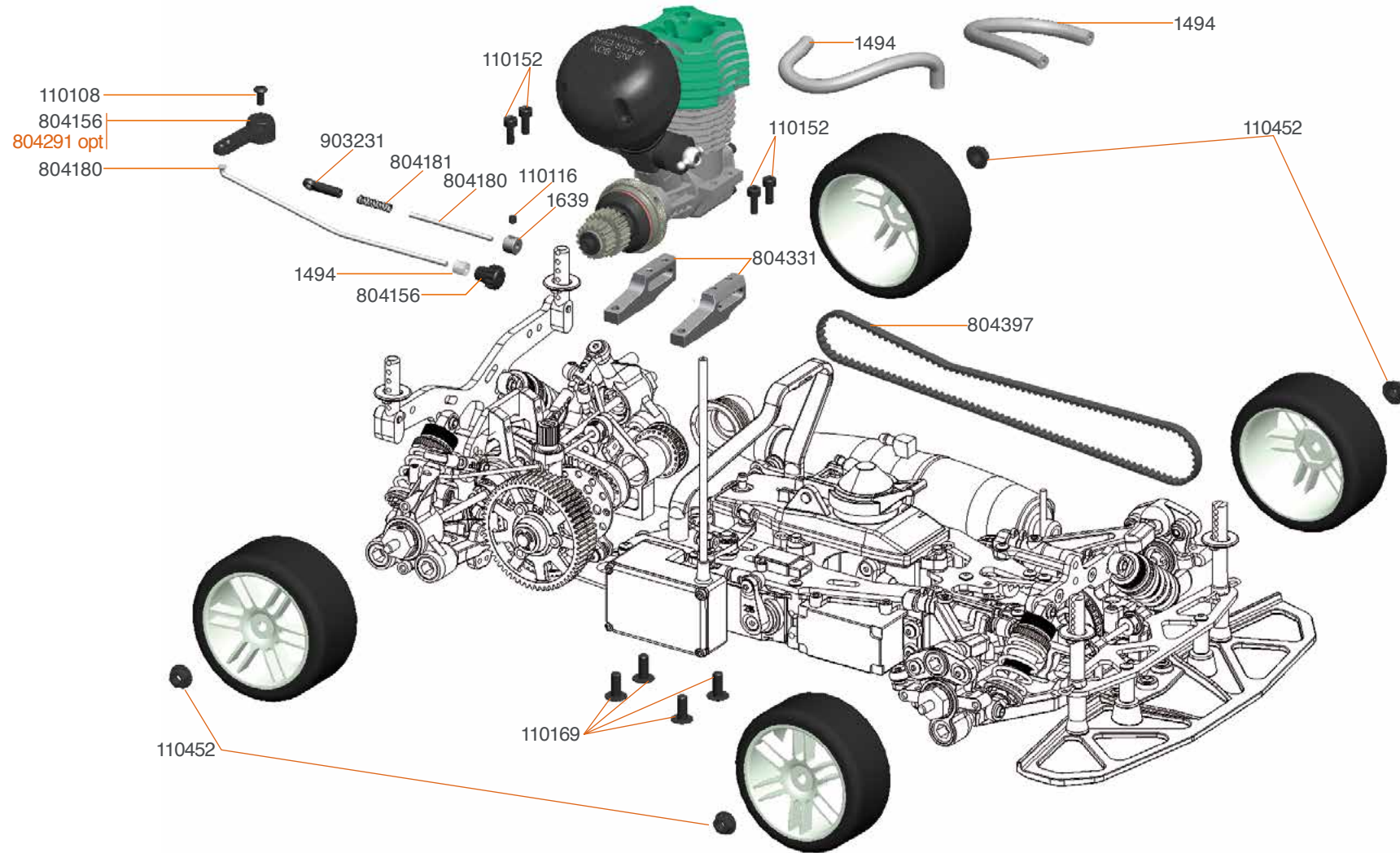

804291 Brake lever on-road alu

TEAM SERPENT NETWORK

748EVO SPARE PARTS www.serpent.com/804010/spares/



748EVO OPTIONALS PARTS www.serpent.com/804010/Optionals/



SERPENT TOOLS www.serpent.com/product/Tools/



SERPENT MERCHANDISING www.serpent.com/product/Merchandising/



SERPENT WEBSITE AND BLOG

www.serpent.com
www.teamserpent.com
www.dragon-rc.com

SERPENT PROMO PAGES <http://promo.serpent.com>

SERPENT FACEBOOK GROUPS <http://promo.serpent.com/indexfb.htm>

SERPENT ADVANCED MANUALS <http://promo.serpent.com/sam/>

SERPENT SOCIAL MEDIA



www.facebook.com/SerpentMRC



www.youtube.com/user/SerpentMRC



www.twitter.com/SerpentMRC



www.plus.google.com/+SerpentModelcars/posts



www.weibo.com/teamserpent

NATRIX 748 WC

**INSTRUCTION
MANUAL**

GP

1/10 scale 4wd



Manual 748 WC #62790 1